



# M1-V

USER MANUAL

VERSION 1.0.2

# SAFETY

**Safety:** This radio generates RF electromagnetic energy during transmit mode. This radio is designed for and classified as "Occupational Use Only," meaning it must be used only during the course of employment by individuals aware of the hazards, and the ways to minimize such hazards. This radio is NOT intended for use by the "General Population" in an uncontrolled environment. This radio has been tested and complies with the FCC RF exposure limits for "Occupational Use Only". In addition, this radio complies with the following Standards and Guidelines with regard to RF energy and electromagnetic energy levels and evaluation of such levels for exposure to humans: FCC OET Bulletin 65 Edition 97-01 Supplement C, Evaluating Compliance with FCC Guidelines for Human Exposure to Radio Frequency Electromagnetic Fields, American National Standards Institute [C95.1-1992], IEEE Standard for Safety Levels with Respect to Human Exposure to Radio Frequency Electromagnetic Fields, 3 kHz to 300 GHz, American National Standards Institute [C95.3-1992], IEEE Recommended Practice for the Measurement of Potentially Hazardous Electromagnetic Fields— RF and Microwave. The following accessories are authorized for use with this product, use of accessories other than those (listed in the instruction) specified may result in RE exposure levels exceed the FCC requirements for wireless RE exposure. To ensure that your exposure to RF electromagnetic energy is within the FCC allowable limits for occupational use, always adhere to the following guidelines: DO NOT operate the radio without a proper antenna attached, as this may damage the radio and may also cause you to exceed FCC RF exposure limits. A proper antenna is the antenna supplied with this radio by the manufacturer or antenna specifically authorized by the manufacturer for use with this radio. DO NOT transmit for more than 50% of total radio use time. Transmitting more than 50% of the time can cause FCC RF exposure compliance requirements to be exceeded. The radio is transmitting when the 'TX indicator' lights up red. You can cause the radio to transmit by pressing the PTT switch. ALWAYS keep the antenna at least 2.5 cm (1 inch) away from the body when transmitting and only use the provided belt-clip to ensure FCC RF exposure compliance requirements are not exceeded. To provide the recipients of your transmission the best sound quality, hold the antenna at least 5 cm (2 inches) from your mouth, and slightly off to one side. The information outlined in this manual provides the user with the information needed to make him or her aware of RF exposure and what to do in order to assure this radio is operated safely within the FCC exposure limits.

**Electromagnetic Interference/Compatibility During Transmission:** Your radio generates RF energy that can possibly cause interference with other devices or systems. To avoid such interference, turn off the radio in areas where signs are posted to do so. DO NOT operate the transmitter in areas that are sensitive to electromagnetic radiation such as hospitals, aircraft, and blasting sites.

**Occupational/Controlled Use:** The radio transmitter is used in situations in which persons are exposed as consequence of their employment provided those persons are fully aware of the potential for exposure and can exercise control over their exposure.





To program your radio and to access advanced features, visit

**[rtsystemsinc.com](http://rtsystemsinc.com)**

or contact them at 800-921-4834

# CONTENTS

<b>User Safety Information</b>	<b>05</b>
<b>Package Includes</b>	<b>06</b>
<b>Main Features</b>	<b>07</b>
<b>Installation</b>	<b>08</b>
Mobile Installation	08
DC Power Cable Connection	09
Replacing Fuses	10
<b>Antenna and Cable</b>	<b>11</b>
Installing the Antenna	12
<b>Getting Acquainted</b>	<b>13</b>
Front Panel Operation	13
Rear Panel Operation	<b>14</b>
Transmitting	15
Menu	16
Messages Expanded	18
Call Log Expanded	20
Settings Expanded	21
<b>Troubleshooting</b>	<b>25</b>
<b>Specifications</b>	<b>26</b>
General	26
Receiver	27
Transmitter	28
<b>Notes</b>	<b>29</b>

## **USER SAFETY INFORMATION**

- Do not attempt to configure your radio while driving.
- This radio is designed for a 12 Volt DC power supply. Do not use a 24 Volt battery to power this radio.
- Keep this radio away from devices that cause interference, such as TV's, Generators, etc.
- Do not expose the radio to long periods of direct sunlight. Do not expose the radio to heat sources.
- If an abnormal odor or smoke is detected coming from the radio, turn off the power immediately and contact your dealer.
- Do not transmit at high power for extended periods as overheating may occur.

## **PACKAGE INCLUDES**

- Radio unit x 1
- Hand Mic with Scosche® MagicMount Magnetic Mount x 1
- Scosche® Magnetic Hand Mic Hanger x 1
- Mobile mounting bracket x 1
- DC power cable with fuse holder x 1
- Screw packs x 1
- Protection fuses x 1

## MAIN FEATURES

A powerful amplifier, streamlined circuits, and an efficient receiver make the Rugged M1 Mobile 2-way radio go the distance. Designed from the ground up in Arroyo Grande, CA, the Rugged M1 is the culmination of decades of communications accessory manufacturing and first-hand off-road race support from Baja to Crandon, and beyond. The result is an IP67 waterproof radio with an all-aluminum chassis that protects vital circuits from Radio Frequency Interference (RFI). With a large, easy to read display, quick access controls, an intuitive interface, and remote-mounted Accessory Hub for quick-access programming and external speaker connection, the Rugged M1 has set the bar for professional 2-way radio communications

### FEATURES:

- Waterproof, IP67 sealed housing
- Superior digital audio clarity
- Ergonomic Hand Mic with Scosche® MagicMount Magnetic Mount
- Digital / Analog VHF band mobile transceiver
- Powerful Mitsubishi Transmit (TX) amplifier
- Clear-Hear Superheterodyne receiver
- Programmable, Quick-Access controls
- RFI reflective aluminum chassis
- Large, Easy to read LED Display
- Easy access remote Accessory Hub
- Upgradeable firmware
- 55 Watts

# INSTALLATION

## MOBILE INSTALLATION

Mobile Installation: Select a location that is safe and easy to reach, and protect you and your passengers while the vehicle is in motion. Consider installing the radio in a location and position in which knees and legs will not strike it during sudden braking. Choose a well-ventilated location that is shielded from direct sunlight and heat sources.

**Note:** Extreme care should be taken if drilling into the dash or other areas of any vehicle to avoid damaging vehicle components.

1. Install the mounting bracket in the vehicle using the supplied self-tapping screws.

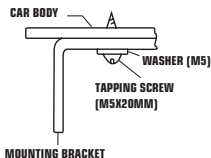
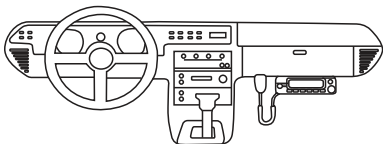
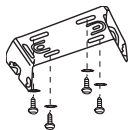

2. Position the radio, then insert and tighten the supplied hex/Phillips screws.
  - Determine the appropriate angle of the radio using the 3 screw hole positions on the side of the mounting bracket.
  - Double check that all screws are tightened to prevent vehicle vibration from loosening the bracket or radio.



# INSTALLATION

## DC POWER CABLE CONNECTION

This radio is designed to operate on 12 Volt systems. Never connect to a 24 Volt system without reducing to 12 Volts. If the power supply is lower than 12 Volts, the display may darken during transmissions, transmit power may decrease dramatically, and/or, the radio may reboot. **Note:** Loose or poor connections can also cause this.

1. Route the DC power cable supplied with the radio directly to the vehicle's battery terminals using the shortest path from the radio. We suggest you do not use the cigarette lighter socket as some cigarette lighter sockets introduce an unacceptable voltage drop. The entire length of the cable must be routed so it is isolated from heat, moisture and the engine secondary (high voltage) ignition system, componets, or cables.
2. Confirm the correct polarity of the connections, then attach the power cable to the battery terminals: Red connects to the positive (+) terminal and black connects to the negative (-) terminal. **Note:** Connecting the power cables incorrectly will damage the radio!
3. Connect the DC power cable to the radio's power supply connector: Press the connectors firmly together until the locking tab clicks.

**Note:** If you use the radio for a long period when the vehicle battery is not fully charged or when the engine is OFF, the battery may become discharged and will not have sufficient reserves to start the vehicle. Avoid using the radio in these conditions.

# INSTALLATION

## REPLACING FUSES

If a fuse blows, determine the cause and correct the problem. After the problem is resolved replace the fuse. If newly installed fuses continue to blow, disconnect the power cable and contact Rugged Radios for assistance. Only use fuses of the specified type and rating otherwise the radio could be damaged.

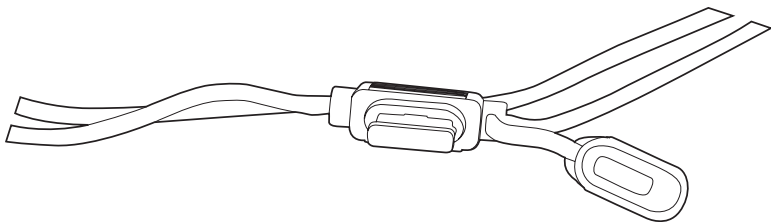

Fuse Location	Fuse Current Rating
Transceiver	15A

## **ANTENNA AND CABLE**

Radio performance relies greatly on the antenna and antenna cable!

Before operating, install an efficient well-tuned antenna and a high-quality antenna cable. Failure to do so will reduce transmit and receive range, radio call clarity, and can damage the radio.

Notes:

- This radio must be used with a 50Ω impedance antenna and antenna cable
- Transmitting without an antenna may damage the radio

## INSTALLING THE ANTENNA

For vehicle-mounting, the best place for an antenna is the center of a metal roof. Note that if your specific vehicle configuration, accessories, or intended use do not allow this, radio range may decrease.

For the best range in VHF applications, only the Rugged Radios VHF-1/2W-SPR antenna should be used. Specific installation requirements vary between vehicles. Use the following guidelines to install the antenna. Where you locate your antenna does make a difference!

1. Mount the antenna as high on the vehicle as possible. The higher the better.
2. If possible, mount the antenna in the center of a metal roof
3. Be sure the mounting location is clean and dry before installing the antenna.
4. Route the antenna cable through an accessible entry point, such as a door or trunk opening.
5. When routing the antenna cable inside the vehicle, keep the cable away from noise sources, such as the ignition system, gauges, etc.
6. Exercise care to prevent cable damage. Make use of existing gaskets, grommets and weather stripping to protect the cable along its route.

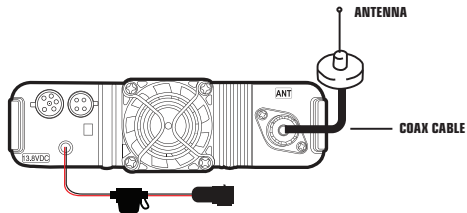

**Important:** Mount antenna up high and do not coil-up excess cable.

# GETTING ACQUAINTED

## FRONT PANEL OPERATION

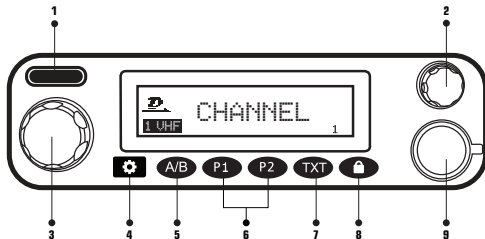

No.	Key	Function
1	Indicator Light	Illuminates while transmitting.
2	Volume Knob	Turns radio ON/OFF and controls volume.
3	Channel Knob	Turn to change channels.
4	Function Key	Quick-press to enter the menu/confirm.
5	A/B	While in dual monitor mode, switches between channel A and B
6	P1/P2 Settings	Quick-press P1 for channel 1, quick-press P2 for channel 2.
7	TXT	While on digital channel will open text mailbox.
8	Lock	Quick-press for back/escape. Long-press for lock/unlock.
9	Microphone Port	5-Pin connection port for included hand-mic.

# GETTING ACQUAINTED

## REAR PANEL OPERATION

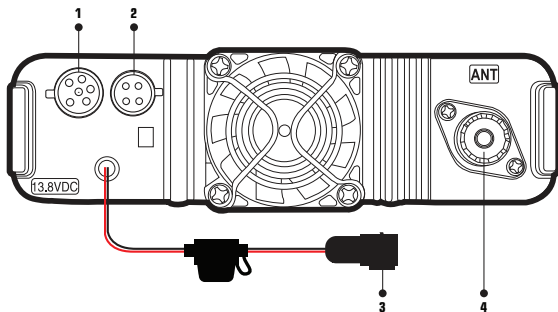

No.	Port	Function
1	Intercom	Port to attach cable to go to intercom.
2	Speaker/ Programming	Port to attach cable for external speaker and programming cable.
3	Power	Connector to connect to the power cable.
4	Antenna	Port to attach coax cable from antenna.

# GETTING ACQUAINTED

## TRANSMITTING

No.	Icon	Function
1	PTT	To transmit, hold microphone approximately 4 inches from mouth, press the key [#1], and speak into microphone.

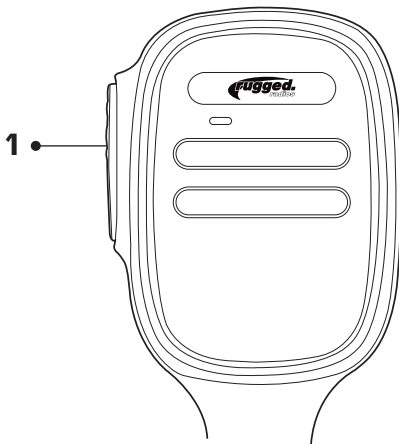

# GETTING ACQUAINTED

## MENU

Menu Item	Operation
Scan	<p>This function is designed to scan for signals in every channel on the scan list.</p> <p>Press [ ⚙ ] to open settings menu. Use the Channel Knob to scroll to SCAN and press [ ⚙ ] to accept. Press [ ⚙ ] to select Turn On.</p> <p>To exit scan, press [ ⚙ ] to open settings menu. Use the Channel Knob to scroll to SCAN and press [ ⚙ ] to accept. Press [ ⚙ ] to select Turn Off.</p>
Zone Selection	<p>Press [ ⚙ ] to open settings menu. Use the Channel Knob to scroll to ZONE and press [ ⚙ ] to accept. Use the Channel Knob to scroll to desired zone and press [ ⚙ ] to accept.</p>



# GETTING ACQUAINTED

## MENU

Menu Item	Operation
Messages (Only Shown When Selected Zone is Digital)	Press [TXT]. Or Press [ ⚙ ] to open settings menu. Use the Channel Knob to scroll to Messages and press [ ⚙ ] to accept.
Call Log (Only Shown When Selected Zone is Digital)	Press [ ⚙ ] to open settings menu. Use the Channel Knob to scroll to Call Log and press [ ⚙ ] to accept.
Utilities	Press [ ⚙ ] to open settings menu. Use the Channel Knob to scroll to Utilities and press [ ⚙ ] to accept. Use the Channel Knob to scroll to Radio Settings, for settings, or Radio Info, for firmware information. Press [ ⚙ ] to accept.

# GETTING ACQUAINTED



## MESSAGES EXPANDED

Menu Item	Function	Operation
Inbox	All recieved text messages will be stored here.	When in the Messages menu, use the Channel Knob to scroll to Inbox and press [ ⚙ ] to accept.
Quick Text	Choose from preprogramed text messages to send or send your own programmed quick texts.*	When in the Messages menu, use the Channel Knob to scroll to Quick Text and press [ ⚙ ] to accept. Use the Channel Knob to scroll to the desired, preprogramed text message and press [ ⚙ ] to accept. Review the selected text message then press [ ⚙ ] to accept. Use the Channel Knob to select Send, Save, or Clear then press [ ⚙ ] to accept.

\*Enabled via software available from RT Systems.



# GETTING ACQUAINTED

## MESSAGES EXPANDED

Menu Item	Function	Operation
Sent Items	All sent text messages will be stored here.	When in the Messages menu, use the Channel Knob to scroll to Sent Items and press [  ] to accept.
Drafts	All text messages saved as draft will be stored here.	When in the Messages menu, use the Channel Knob to scroll to Sent Items and press [  ] to accept.



# GETTING ACQUAINTED

## CALL LOG EXPANDED

Menu Item	Operation
Record	<p>When receiving or transmitting in a digital zone this feature will keep a record of all transmissions from the radio and transmissions received by the radio. You can toggle this feature on and off in Radio Settings.</p> <p>From the Call Log menu, press [  ] to open the Directory. All radio transmissions will be stored here organized by day. Use the Channel Knob to scroll to the desired day and press [  ] to enter. When in the Record use the Channel Knob to scroll to Play, Destination ID, Source ID, Date, Time, Tx/Rx, or RecordTime and press [  ] to enter.</p>





# GETTING ACQUAINTED

## SETTINGS EXPANDED

Menu Item	Operation
Tones/Alerts	<p>When in the Settings menu, use the Channel Knob to scroll to Tones/Alerts and press [  ] to accept. Use the Channel Knob to scroll to All Tones or Talk Permit.</p> <p>All Tones: Enable or disable all radio tones and prompts.</p> <p>Talk Permit: Enable or disable the "Talk Permit" tone, heard after pressing the PTT, to indicate permission to talk.</p>
Backlight	<p>When in the Settings menu, use the Channel Knob to scroll to Backlight and press [  ] to accept. Use the Channel Knob to select the desired Backlight timing and press [  ] to accept.</p>









# GETTING ACQUAINTED

## SETTINGS EXPANDED

Menu Item	Operation
Squelch	<p>Squelch system allows you to mute the background noise when no signal is being received. Not only is the Squelch system “standby” operation more pleasant, it also significantly reduces battery current consumption.</p> <p>When in the Settings menu, use the Channel Knob to scroll to Squelch and press [  ] to accept. Use the Channel Knob to scroll to the desired Squelch level and press [  ] to accept.</p>
Auto Lock	<p>Choose whether to lock the radio keypad manually or automatically.</p> <p>When in the Settings menu, use the Channel Knob to scroll to Auto Lock and press [  ] to accept. Use the Channel Knob to select: Manual, 5S, 10S, or 15S and press [  ] to accept.</p>





# GETTING ACQUAINTED

## SETTINGS EXPANDED

Menu Item	Operation
Record	<p>Toggle the Record feature on or off.</p> <p>When in the Settings menu, use the Channel Knob to scroll to Record and press [  ] to accept. Use the Channel Knob to select the desired setting and and press [  ] to accept.</p>
Clock	<p>When in the Settings menu, use the Channel Knob to scroll to Clock and press [  ] to accept. Scroll to choose Time, Date, or Timezone and press [  ] to accept. Press [  ] to edit the desired setting. Use [P1] and [P2] to scroll through digits and use the Channel Knob to edit selected digit. Press [  ] to save setting.</p>
Menu Timeout	<p>When in the Settings menu, use the Channel Knob to scroll to Menu Timeout and press [  ] to accept. Use the Channel Knob to select the desired setting and press [  ] to accept.</p>

# GETTING ACQUAINTED

## SETTINGS EXPANDED

Menu Item	Operation
Monitor	Monitor will temporarily change the squelch to zero allowing you to hear very weak signals. When in the Settings menu, use the Channel Knob to scroll to Monitor and press [  ] to accept. Use the channel knob to select Turn On or Turn Off then press [  ] to accept.
Dual Monitor	Dual Monitor will allow you to monitor two channels at once. When in the Settings menu, use the Channel Knob to scroll to Dual Monitor and press [  ] to accept. Use the channel knob to select Turn On or Turn Off then press [  ] to accept.



## TROUBLESHOOTING

<b>Problem</b>	<b>Possible Cause and Potential Solutions</b>
(a) Power is on, nothing appears on Display.	+ and - polarities of power connection are reversed. Connect red lead to plus terminal and black lead to minus terminal of DC power supply.
(b) Fuse is blown.	Check and solve problem resulting in blown fuse and replace fuse with new fuse.
(c) No sound comes from speaker	Squelch is muted. Decrease squelch level. Tone or CTCSS/DCS squelch is active. Turn CTCSS or DCS squelch off. 3.5mm external speaker jack is occupied.
(d) Key and Dial do not function.	Key-lock function is activated. Cancel Key-lock function.

For additional help call our Tech Department at (888) 541-7223. We are here to help!

HOURS OF OPERATION: Monday - Friday: 8:00 AM - 5:00 PM PST

# SPECIFICATIONS

## GENERAL

Frequency Range	VHF: 136-174 MHz
Channel Capacity	1000
PLL Channel Spacing	6.25/25/12.5/25KHz
Voltage Rating	13.8V DC
Operating temperature	-30°C ~ +60°C
Storage temperature	-30°C ~ +85°C
Dimensions	143x50x175mm
Compatible with American Military Standard	(MIL-STD-810C/D/E)

# SPECIFICATIONS

## RECEIVER

Frequency stability [-20C +60C, +25°C]	+/-1.0ppm
Digital Sensibility	0.3uV/-117.4dBm(BER 5%) 0.7uV/-110dBm(BER 1%)
Analogue Sensibility	0.35uV/-116dBm(20dB SINAD) 0.22uV/-120dBm(20dB SINAD)
Rated audio	5W
Adjacent Channel Selectivity	TIA603C:60 dB@ 12.5kHz ETSI: 60 dB@ 12.5kHz
Intermodulation	TIA603C:65 dB ETSI: 65 dB
CO-channel Rejection	12 dB@ 12.5kHz
Spurious Rejection	TIA603C:70 dB ETSI: 70 dB
Audio distortion @ rated audio	≤ 3%
FM Hum and Noise	-40dB @12.5kHz
Audio response	+1 dB-3dB
Spurious emission	-57dBm@< 1 GHz -47dBm@>1GHz
Block	84dB

# SPECIFICATIONS

## TRANSMITTER

FM Hum and Noise	-40dB @12.5kHz
Modulation limited	+/-2.5kHz @ 12.5kHz
Conducted/radiated emission	-36 dBm < 1 GHz -30 dBm >1Ghz < 4GHz
Adjacent channel power	-60 dB @12.5kHz -65 dB @ 25kHz
Audio Response	+1dB-3dB
Audio distortion	3%
FM modulation	12.5kHz: 11K0F3E
4FSK digital modulation	12.5kHz only data:7K60FXD 12.5kHz data and audio:7K60FXE
Digital Protocol	ETSI TS 102361-1, -2, -3
Digital vocoder type	AMBE++
Digital agreement	DMR





[WWW.RUGGEDRADIOS.COM](http://WWW.RUGGEDRADIOS.COM)