

Acabado / Finish / Terminare / Acabamento / Finitio

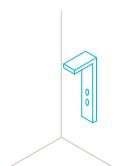

Cromado
Chromed
Chromé
Cromado
Cromato

Instalación / Installation / Installation / Instalação/ Installazione



Frontal
Frontal
Frontale
Frontal
Frontale

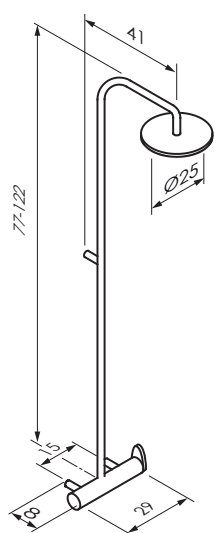

cm

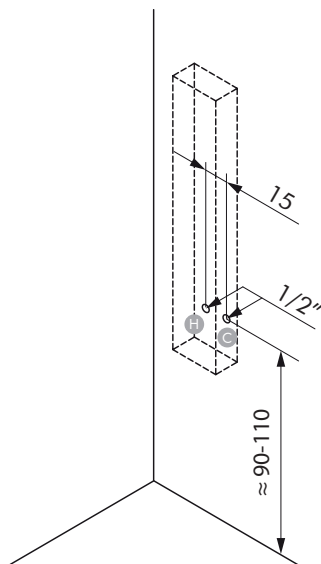

cm



dim.cm	ref.	P kg	P' kg	V cmxcmxcm
29x77-122	COMET715	3,4	4,26	87x32x8

C Agua fría / Cold water / Eau froide / Água fria / Acqua fredda

H Agua caliente / Hot water / Eau chaude / Água quente / Acqua calda

P: Peso neto / Net weight / Poids net / Peso líquido / Peso netto

P': Peso de expedición / Expedition Weight / Poids d'expédition / Peso do expedição / Peso spedizione

V: Volumen de expedición / Expedition Volume / Volume d'expédition / Volume do expedição / Volume spedizione

Características	Features	Caractéristiques	Características	Caratteristiche
Monomando	Mixer	Mélangeur	Monomando	Monomando
Altura extensible	Extensible height	Hauter extensible	Altura extensível	Altezza estensibile
Flexible 150 cm	Hose 150 cm	Flexible 150 cm	Bicha 150 cm	Flessibile 150 cm
Presión de la intalación 1,5-4 bars	Pressure of the installation 1,5-4 bars	La pression du système 1,5-4 bars	Pressão do sistema 1,5-4 bars	Pressione del sistema 1,5-4 bars