

Diagram

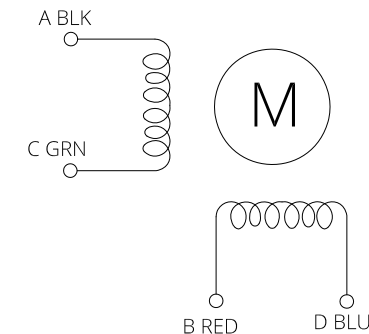

Item	Specification	Item	Specification
Phase Number	2	Step Angle	0.9° ± 5%
Rated Voltage	DC 3.0V / Phase	Rated Current	DC 2.5A / Phase
Phase Resistance	1.2x(1±20%) Ω	Phase Inductance	1.5x(1±20%) mH
Holding Torque	4.5Kgf-cm (45N-cm)	Detent Torque	20 mN-m REF.
Rotate Direction	A-AB-B CW	Insulate Resistance	100Mohm(DC500V)
HI-POT	AC600V/1mA/1S	Insulation Class	Class B 130°C
Rotor Inertia	85 g-cm ² REF	Weight	0.35 Kg REF

Winding magnet wire need to be Class F 155C. (绕组漆包线必须用F级)

A		NEW RELEASE		Xu SD	J.B.	9/9/21
REV.	ECN NO.	DESCRIPTION		MADE BY	APPR. BY	DATE
		VIEW	LDO Motors Co., Ltd.			
		SCALE	Part NO. 0.9° NEMA17 Stepper Motor LDO-42STH48-2504MAC(F)			
DRAWN BY	CHECKED BY	APPR. BY	DATE	FACTORY CODE	SHEET NO.	
Xu SD	J.B.	J.B.	9/9/21		1/1	