

0.9° SLIM POWER

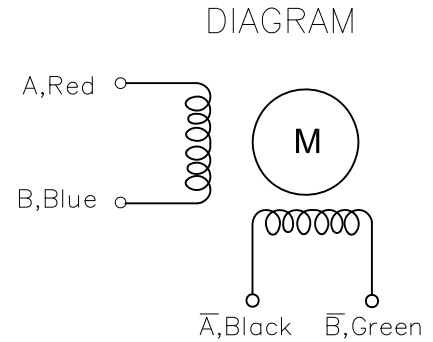
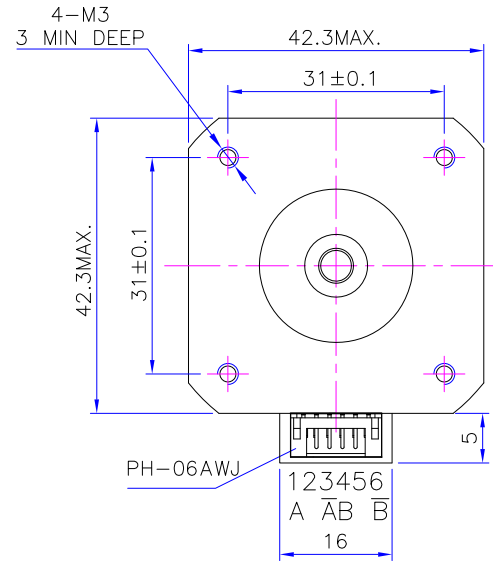
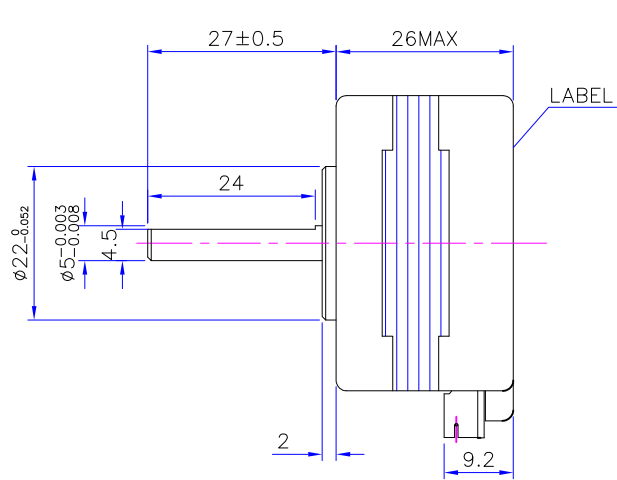

Label by laser print

LDOMOTORS.COM
 0.9° Slim Power Stepper
 LDO-42STH25-1404MAC #YYMMDD

Supply with detachable cable.

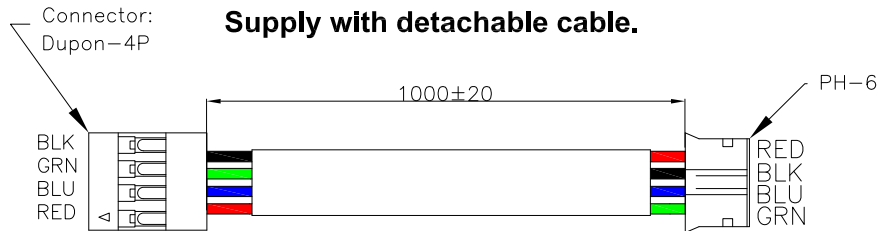

0.9° SLIM POWER

Items	Specs	Items	Specs							
Phase Number	2 phases	Rotate Direction	A-B-A̅-B̅-A CW	A	---	New Release	SD XU	J.B.	6/13/19	
Step Angle	0.9°±5%	HI POT	AC600V/1mA/1S	REV	ECN NO	Description	Made by	Approve	Date	
Resistance	2.4±15% ohm	Insulation Resistance	≥ 100 MΩ(DC 500V)				LDO MOTORS CO.,LTD Hybrid Stepper Motor LDO-42STH25-1404MAC(TIM)			
Rated Current	DC 1.4 A /Phase	Insulation Class	Class B							
Holding Torque	≥18N.cm	Weight	0.15 Kg REF.	Des.	Check	Appr.	Date	Factory Code	217HTNB2002-27	page
Inductance(1kHz)	5.5±20% mH									