

E3D Hermes Datasheet

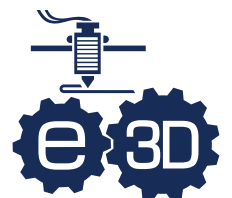

E3D-ONLINE



E3D-ONLINE

E3D Hermes Specification

Summary

- Drive type: dual drive with adjustable tension idler
- Max printing temperature: 285°C (upgradable to 500°C)
- Max: 388g (including V6 hotside)
- Max pushing force: ~10kg*
 - Dependent on filament
- Flow rate (based on V6): 600mm³/min*
 - Dependent on filament
- Nominal steps per mm (16x): 409 steps per mm
- Motor current: 1.33A
- Filament diameter and tolerances: 1.75±0.05mm
- *Not compatible with Nema17 but based upon its design*

Volume & Dimensions

- XYZ dimensions
 - 77 × 44 × 83mm (Direct)
 - 67 × 44 × 76mm (Bowden)

Direct

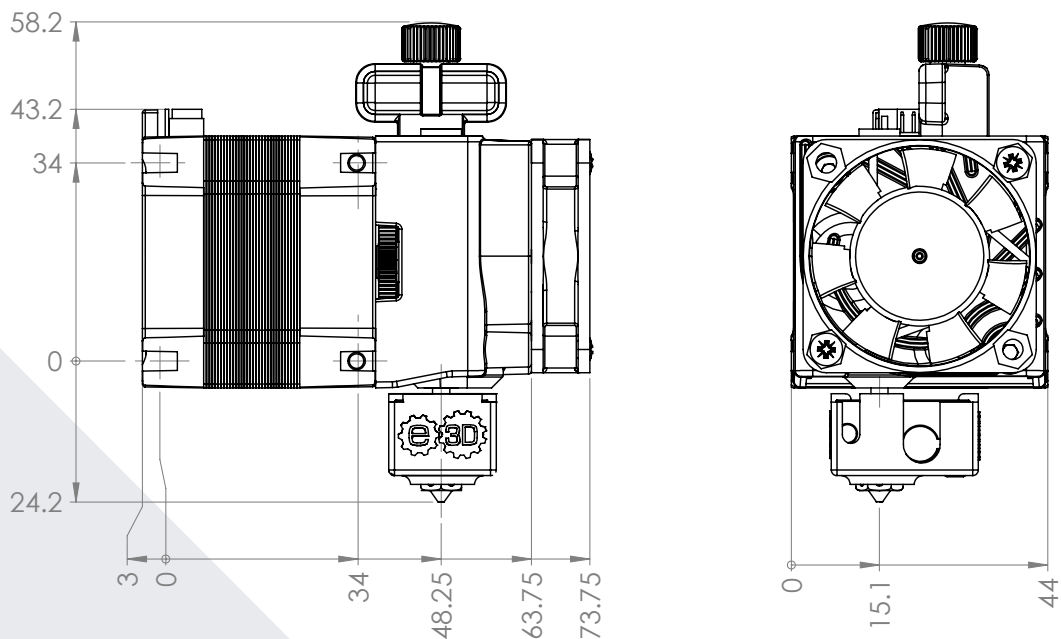



E3D-ONLINE

Bowden

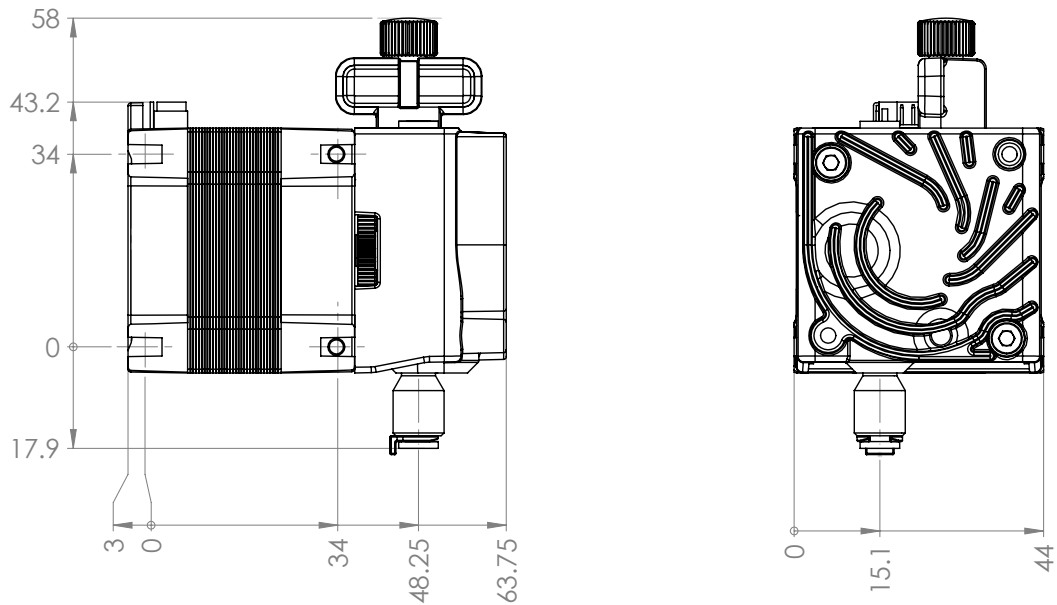

Mass

- 388g Direct (including hotside)
- 327g Bowden

Performance Characteristics

- Max pushing force: ~10kg*
 - Dependent on filament
- Maximum nominal volumetric throughput (PLA print test at 220°C)
 - 600mm³/min*
 - *Results may vary depending on your set-up, higher volumetric throughputs are achievable with Volcano and SuperVolcano
<https://e3d-online.com/blog/2019/02/28/supervolcano/>
- Maximum printing temperature:
 - 285°C
 - Upgradable to 500°C (with copper block, copper nozzle, PT100)



E3D-ONLINE

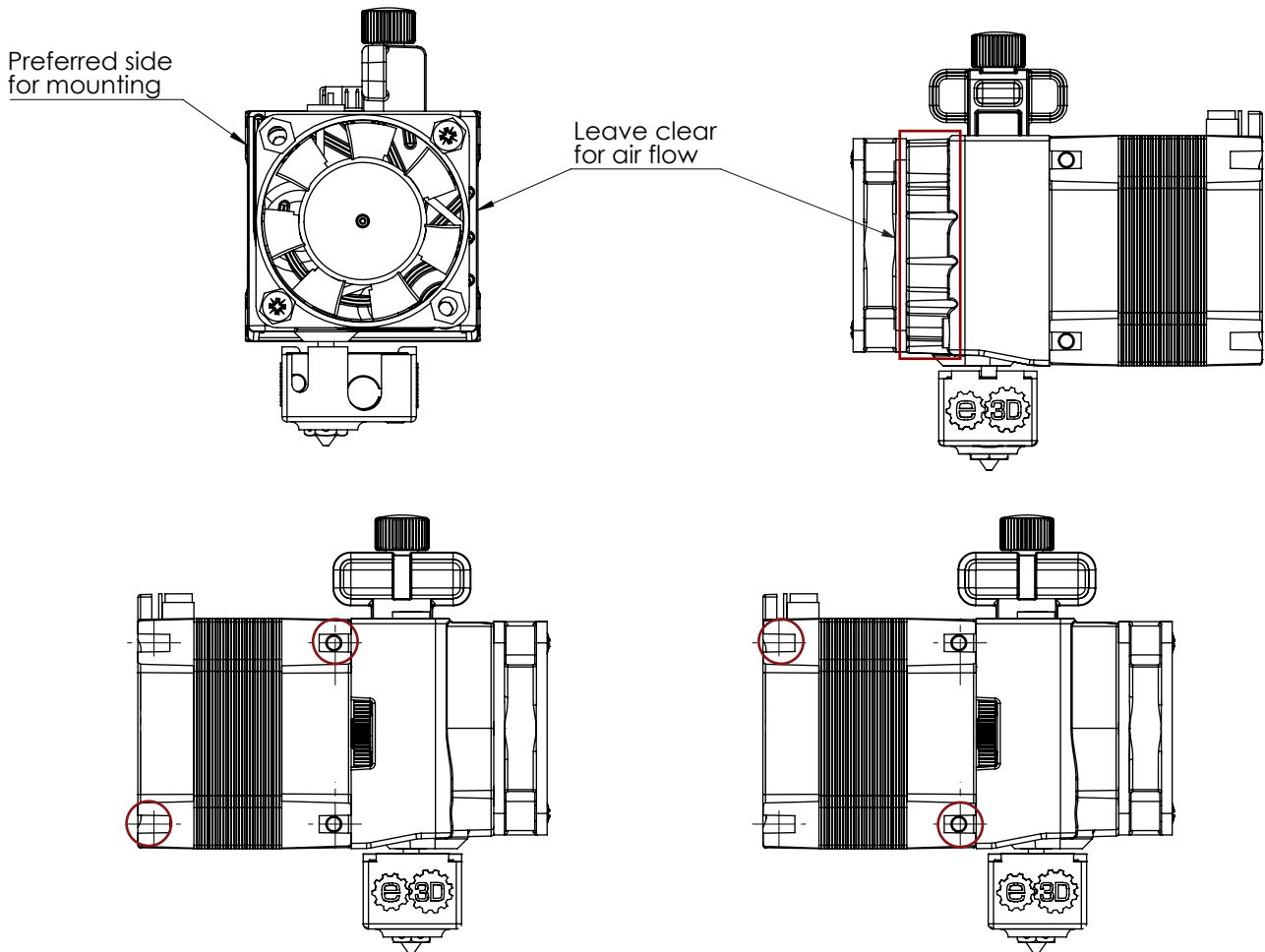

Mounting Guidance

- Hermes is mounted to a flat surface via the T-slots in the left or right sides of the motor
- Typically Hermes is mounted on to the left side, as the air from the heatsink cooling fan exits on the right, if mounting on the right ensure that sufficient space is left for airflow
- The screws should protrude $3\text{mm} \pm 0.25\text{mm}$ from the mounting surface to go into the T-slots
 - The supplied M3x8 mounting screws are suitable for a nominal 5mm mounting plate thickness
- Hermes must be mounted on a minimum of 2 mounting points, if using 2 mounting points, diagonally opposing points should be used, in order to ensure rigidity

Service Temperatures

- Note, these are max ambient service temperatures of the components used, and not a guaranteed operating temperature of the system
 - Fan: 50°C
 - Motor: 85°C
 - Polymer bushing: 90°C
 - Bearings: 100°C
 - Acetal idler components: 120°C



E3D-ONLINE

Gearing Train Specification

- Single stage spur reduction: 3.32:1
 - Motor pinion: 22T MOD 0.25
 - Large gear: 73T MOD 0.25
 - Hobb gears: 20T MOD 0.5
 - Hobb effective diameter: 8.27mm* (Effective diameter will vary with filament type and tension).

Electrical Specification

- Nominal heater power: 30W (can be upgraded)

Fan Specification

	12v	24v
Width	40mm	40mm
Depth	10mm	10mm
Cable	1000mm	1000mm
Voltage	12v	24v
Current	0.08A	0.04A
RPMS	7500±10%	6900±10%
Connector*	Dupont 0.1"	Dupont 0.1"

*Typical connector used on most microcontroller headers

Motor Specification

Items	Specs
Motor cable length	1000mm
Phase no	2 phases
Rated voltage	2.8V
Current	1.33A
Resistance	2.10Ω per phase
Inductance	2.5 mH
Holding torque	3.2 kgcm
Detent torque	0.12 kgcm
Rotate direction	ABAB CW
Max starting PPS	2800 PPS
Max slewing PPS	3500 PPS
Insulation	≥100MΩ (DC 500V)
HI POT	AC 600V/1mA/1S
Insulation class	Class B
Rotor inertia	35gcm ²
Connector	JST - 56B - PH



E3D-ONLINE

Winding Arrangement

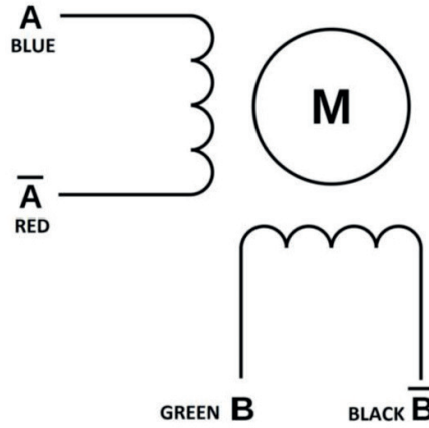

Connector Pinout

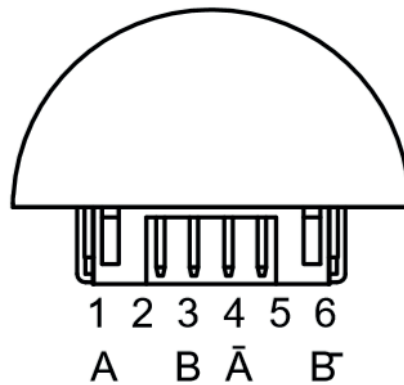

Materials

- Block: aluminium (can be upgraded)
- Nozzle: brass (can be upgraded)
- Heatsink: die cast aluminium
- Heatbreak: stainless steel
- Gear/Hobb materials: stainless steel
- Fixings: steel
- Idler materials: acetal
- Bearing elements:
 - 2x shielded 623 bearings (drive shaft)
 - Igus bushing



E3D-ONLINE

Direct Setup

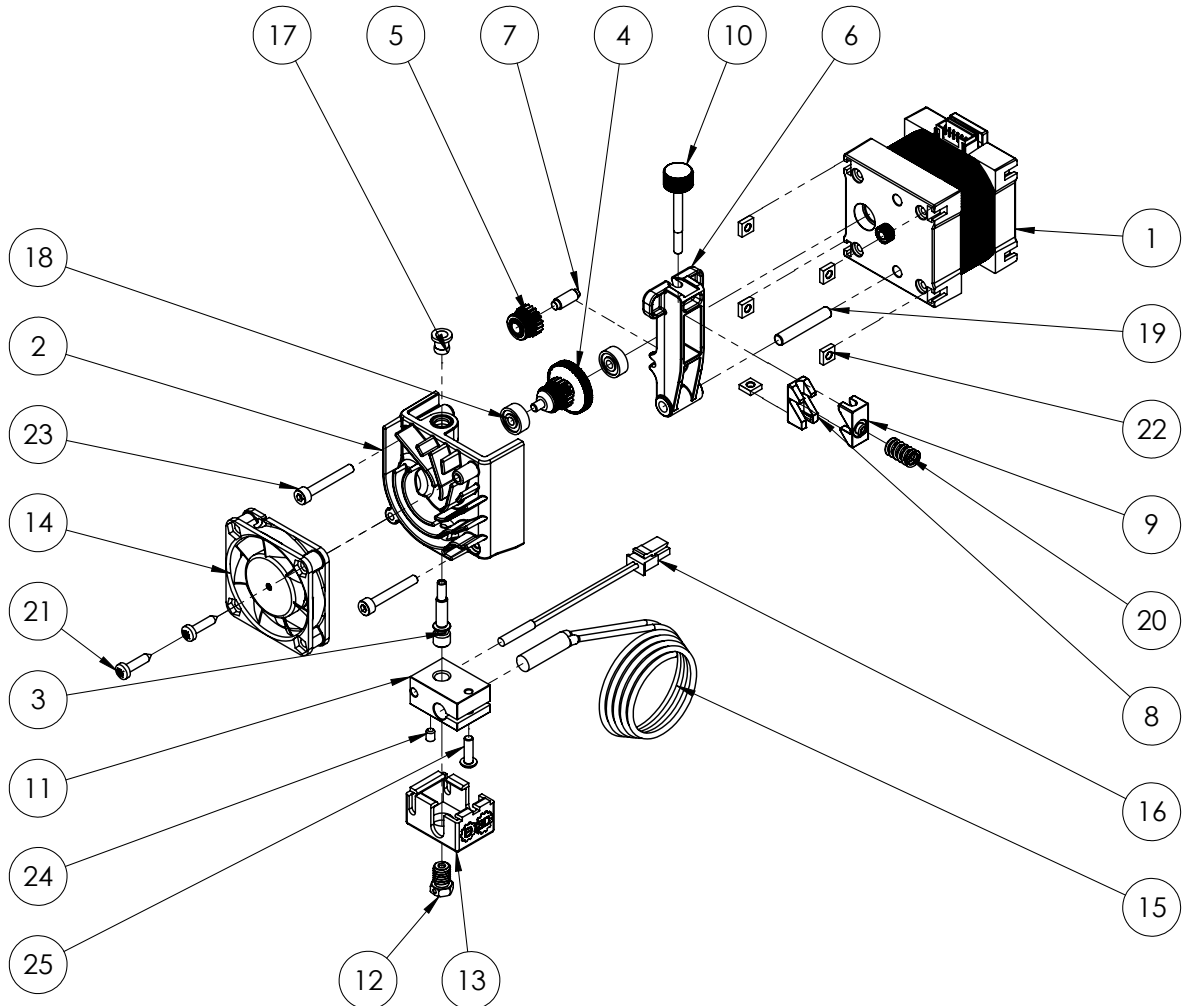

- | | |
|------------------------------------|--|
| 1. Hermes Motor | 14. 40 × 40 × 10 Fan |
| 2. Hermes 1.75 Sink Assembly | 15. Heater Cartridge |
| 3. Hermes 1.75 Break | 16. Thermistor Cartridge |
| 4. Hermes Drive Hobb assembly | 17. 1.75mm Bowden Collet |
| 5. Hermes Idler Hobb Assembly | 18. 623 Bearing (x2) |
| 6. Hermes 1.75 Idler | 19. 4mm x 24mm Dowel |
| 7. Hermes 1.75 Idler Shaft | 20. Spring |
| 8. Hermes Idler Slide block | 21. 2.9 × 13 Self-tapping Screw (x2) |
| 9. Hermes Idler Spring block | 22. M3 Square Nut (x5) |
| 10. Hermes Thumbwheel | 23. M3 × 22 Socket Head Cap Screw (x2) |
| 11. V6 Heater Block | 24. M3 × 4 Grubscrew |
| 12. V6 Brass Nozzle 1.75mm x 0.4mm | 25. M3 X 10 Button Head Cap Screw |
| 13. V6 Sock | |

Bowden Setup

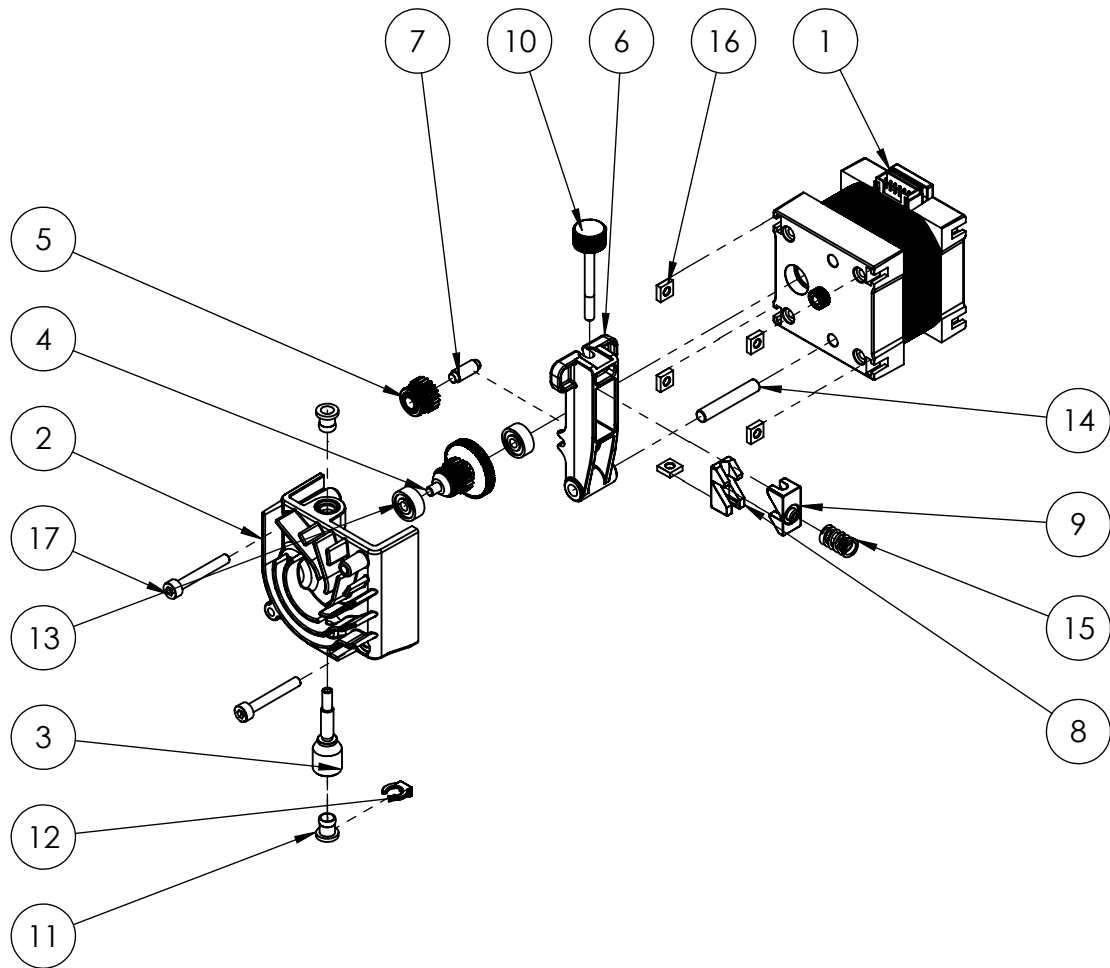

- | | |
|-------------------------------|--------------------------------------|
| 1. Hermes Motor | 13. 623 Bearing (x2) |
| 2. Hermes 1.75 Sink Assembly | 14. 4mm x 24mm Dowel |
| 3. Hermes 1.75 Bowdaptor | 15. Spring |
| 4. Hermes Drive Hobb Assembly | 16. M3 Square Nut (x5) |
| 5. Hermes Idler Hobb Assembly | 17. M3x22 Socket Head Cap Screw (x2) |
| 6. Hermes 1.75 Idler | |
| 7. Hermes 1.75 Idler Shaft | |
| 8. Hermes Idler Slide Block | |
| 9. Hermes Idler Spring Block | |
| 10. Hermes Thumbwheel | |
| 11. 1.75mm Bowden Collet (x2) | |
| 12. 1.75mm Bowden Clip | |