



ENGINEERING BETTER BEER

Pressure Transfer / Kegging

BREW BUCKET DOMED LID OPTION

The Brew Bucket can be modified to perform both open and closed low-pressure transfers with the help of a few add-ons.

Here is a list of parts you will require to install and perform a pressurized transfer:

- (1) Domed lid with 3" TC
 - 7gal Brew Bucket owners will need the 7 gal | Chronical & Brew Buckets version
 - 14gal Brew Bucket BME owners will need the Half bbl | Chronicals & 14 gal Brew Bucket version
- (1) 3" Cap with ½" Blow-off
- (1) 3" TC gasket
- (1) 3" TC Clamp
- Pressurized Transfer Kit | Chronical BME
 - (1) 1.5" TC to ½" Barb
 - (1) 1.5" TC to ¼" MFL
 - (1) TC Clamp
 - (1) TC Gasket
 - (1) 5 ft Length of ½" Silicone Tubing
 - (2) Hose Clamps
- Desired Length of 3/8" Silicone Tubing
- (Optional) Appropriate Keg Adapter

1. Begin by locating the ½" tubing and attach one side to the 3" TC lid cap's blow off barb.
2. Attach the other side of the ½" tubing to the 1.5" TC to ½" Barb fitting, using hose clamps to secure both connections.
3. Attach the 1.5" TC to ½" Barb fitting to the included 1.5" TC to ¼" MFL fitting with a TC clamp and gasket.
4. Lastly, the ¼" MFL connection can interface with common gas line flare fittings used on CO₂ regulators.

PRESSURE TRANSFER / KEGGING

BREW BUCKET DOMED LID OPTION (CONTINUED)

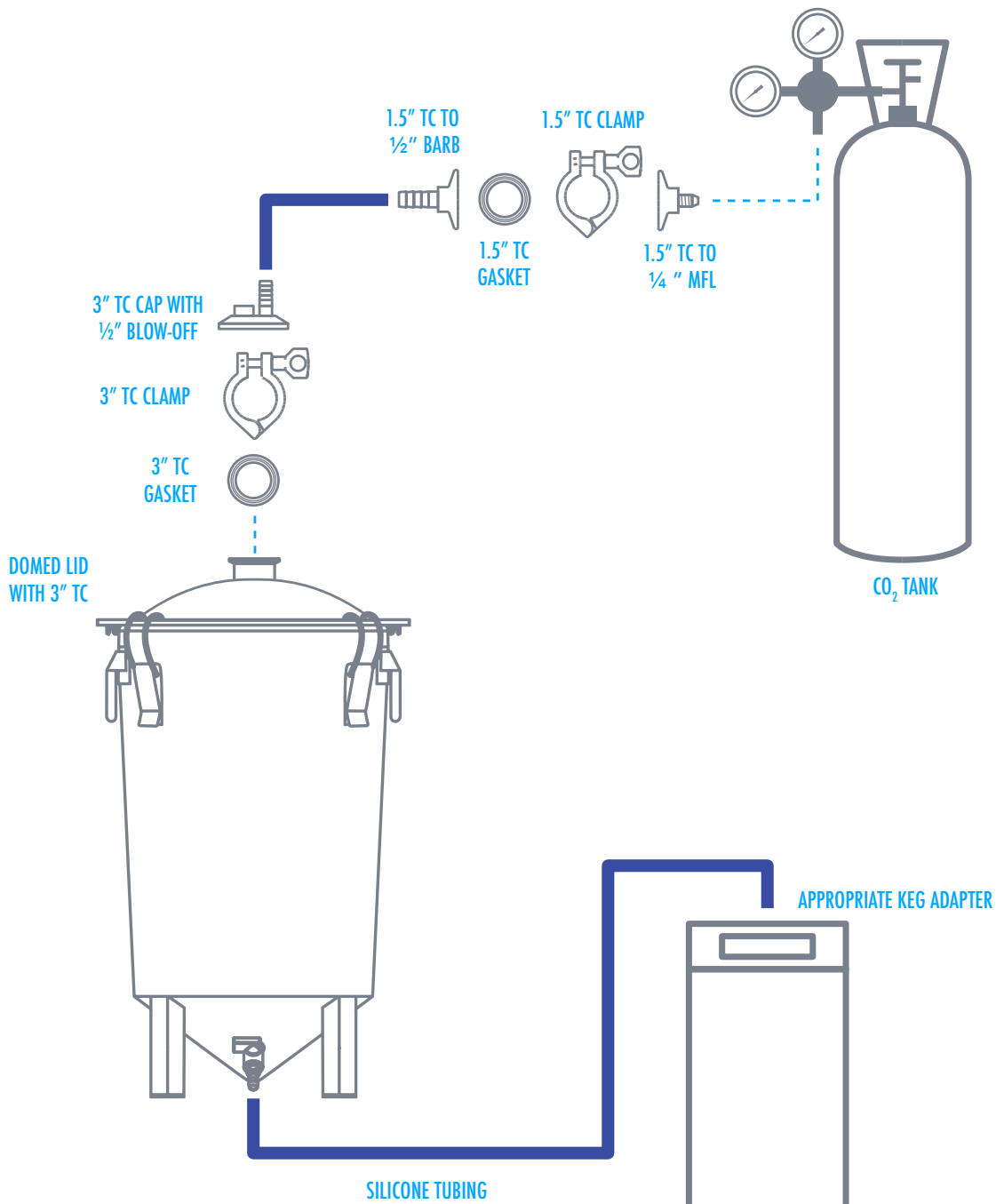

WARNING

Do not to exceed 2 PSI when transferring

NOTE

- USE HOSE CLAMPS ON ALL BARB FITTINGS
USE TEFLON TAPE ON ALL THREADED FITTINGS -

BREW BUCKET FLAT LID OPTION

The Brew Bucket can be modified to perform both open and closed low-pressure transfers with the help of a few add-ons. The 1.5" TC weldless compression fitting accessory will allow flat lid users to perform pressurized transfers without switching to a domed lid. More specifically, the weldless TC flange allows flat lid users to utilize our existing Pressurized Transfer Fitting, in addition to other TC accessories with their FTSs flat lid.

Here is a list of parts you will require to install and perform a pressurized transfer:

- Pressurized Transfer Kit | Chronical
 - (1) Pressurized Transfer Fitting
 - (1) TC Clamp
 - (1) TC Gasket
 - (1) ½" Barb to ½" MPT
 - (1) 5 ft Length of ½" Silicone Tubing
 - (2) Hose Clamps
- (1) 1.5" TC Weldless Compression Fitting
- (1) 17mm Compression Plug and O-ring
- (1) 42mm Hole Saw Drill Bit
- Desired Length of 3/8" Silicone Tubing
- (Optional) Appropriate Keg Adapter

Begin by drilling the 42mm hole in a previously unoccupied area of your flat lid using a low-speed setting on your drill for the cleanest cut as higher speeds will rapidly heat up the pilot bit causing it to potentially fail prematurely. We also recommend the use of a cutting fluid such as Tap Magic. This keeps the hole saw bit cooler and also extends its life. Once the hole is drilled, debur any sharp edges with a household razor blade. Next install the TC Compression Fitting from the top of the lid, ensuring the silicone O-ring forms an air tight seal to the top of the lid, and then tighten the locknut from the underside.

Install the 17mm plug in the previous blow off port, since you will now be using the new compression fitting for both blow-off and pressurized transfers. Keep in mind, If you do not install the plug, there will be no way for pressure to build within the vessel when you go to transfer.

Your Brew Bucket lid is now ready for use. During active fermentation, rig a blow-off by attaching a Hose Barb | ½" to 1.5" TC. Then run a ½" piece of silicone tubing into your blow-off container. You may also use a silicone stopper with an airlock, however, a blow-off is always recommended. Lastly, do not attempt to use the Pressurized Transfer Fitting as a blow off fitting as the 3/8" hose connection can become easily clogged from an overactive fermentation.

When your beer has finished fermenting and you want to perform a pressurized transfer, remove the

BREW BUCKET FLAT LID OPTION (CONTINUED)

blow-off fitting from the weldless TC compression fitting and then install the Pressurized Transfer Fitting. Finally, connect the Pressurized Transfer Fitting to your regulator. Then run a length of tubing from your racking valve to a cleaned, purged and sanitized keg.

Remember to turn down the pressure on your regulator to 0 before beginning the flow of gas. A quick burst of CO₂ in excess of 2.5 PSI can cause damage to your lid clamps. Slowly turn up your gas to roughly 1-2 PSI, and open the racking valve to begin the transfer.

WARNING

Do not to exceed 2 PSI when transferring

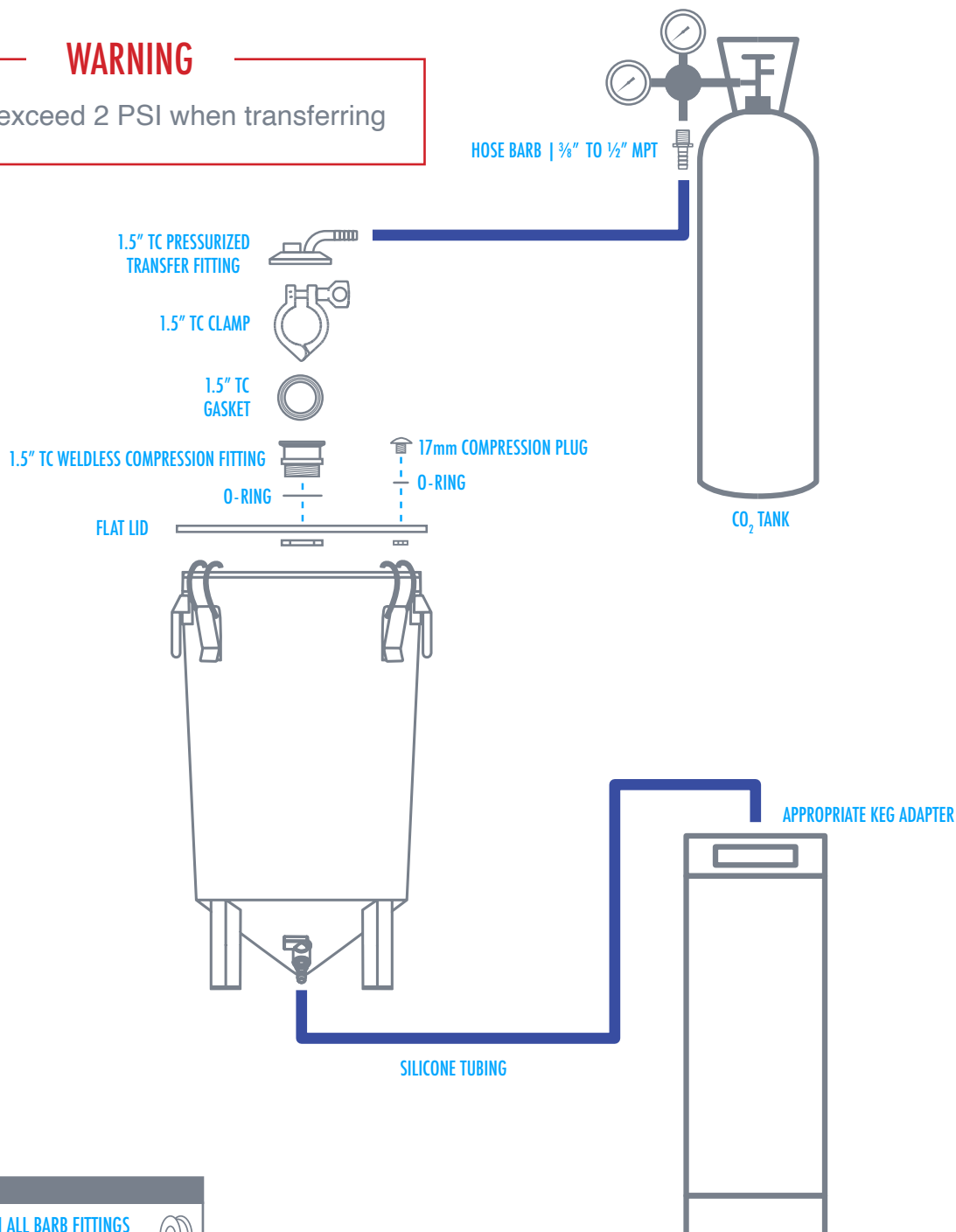

NOTE

- USE HOSE CLAMPS ON ALL BARB FITTINGS -
USE TEFLON TAPE ON ALL THREADED FITTINGS -

CHRONICAL PRESSURIZED TRANSFER KIT

This kit is designed for owners of standard Chronical fermenters and includes everything you need to perform a pressurized transfer.

Here is a list of parts you will require to install and perform a pressurized transfer:

- Pressurized Transfer Kit | Chronical
 - (1) Pressurized Transfer Fitting
 - (1) TC Clamp
 - (1) TC Gasket
 - (1) ½” Barb to ½” MPT
 - (1) 5 ft Length of ½” Silicone Tubing
 - (2) Hose Clamps
- Desired Length of 3/8” Silicone Tubing
- (Optional) Appropriate Keg Adapter

1. Attach the pressurized transfer fitting to your Chronical’s lid with the included TC clamp and gasket.
2. Then attach the pressurized transfer fitting to your CO₂ regulator.
3. Lastly, install the ½” barb to the Chronical’s racking valve, and run the included ½” tubing to a clean and sanitized keg. The pressurized transfer fitting includes a PRV that prevents pressure from building to unsafe levels within your Chronical.

PRESSURE TRANSFER / KEGGING

CHRONICAL PRESSURIZED TRANSFER KIT (CONTINUED)

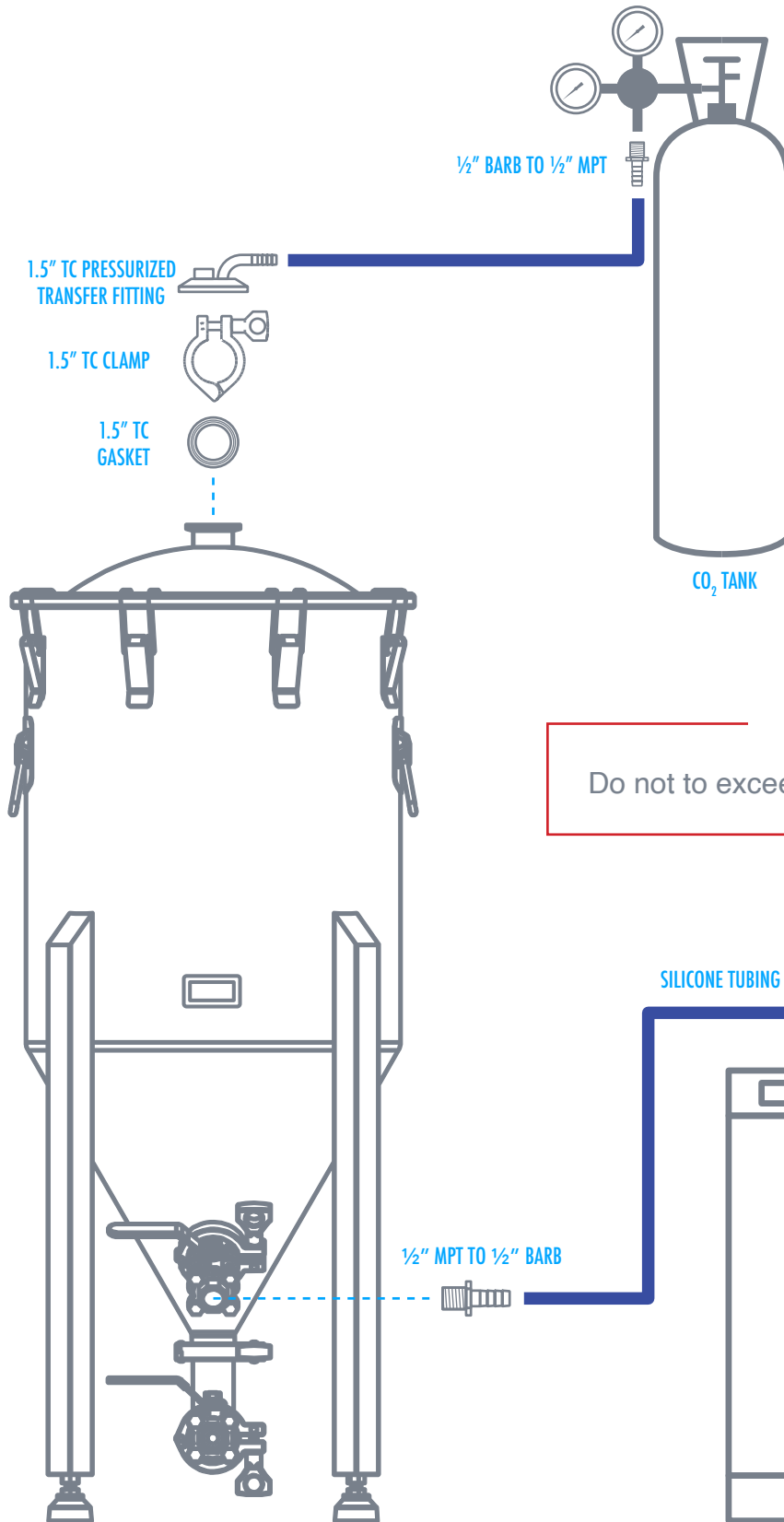

WARNING

Do not to exceed 2 PSI when transferring

NOTE

- USE HOSE CLAMPS ON ALL BARB FITTINGS
USE TEFLON TAPE ON ALL THREADED FITTINGS -

CHRONICAL BME PRESSURIZED TRANSFER KIT

This kit is designed for owners of Chronical BME fermenters and includes everything you need to introduce CO₂ pressure into your fermenter without removing the lid cap and risking O₂ contamination. The Chronical BME's 3" lid cap includes a PRV that prevents pressure from building to unsafe levels.

Here is a list of parts you will require to install and perform a pressurized transfer:

- Pressurized Transfer Kit I Chronical BME
 - (1) 1.5" TC to ½" Barb
 - (1) 1.5" TC to ¼" MFL
 - (1) TC Clamp
 - (1) TC Gasket
 - (1) 5 ft Length of ½" Silicone Tubing
 - (2) Hose Clamps

- Desired Length of 3/8" Silicone Tubing
- (Optional) Appropriate Keg Adapter

Due to the popularity of both open and closed transfers with Chronical BME users, this kit does not include the output side to the keg, so please add a TC ½" barb, 3/8" barb or ¼" MFL fitting and the appropriate tubing for the type of transfer you plan on doing.

1. Begin by locating the ½" tubing and attach one side to the 3" TC lid cap's blow off barb that was included with the Chronical BME.

2. Attach the other side of the ½" tubing to the 1.5" TC to ½" Barb fitting, using hose clamps to secure both connections.

3. Attach the 1.5" TC to ½" Barb fitting to the included 1.5" TC to ¼" MFL fitting with a TC clamp and gasket.

4. Lastly, the ¼" MFL connection can interface with common gas line flare fittings used on CO₂ regulators.

PRESSURE TRANSFER / KEGGING

CHRONICAL BME PRESSURIZED TRANSFER KIT (CONTINUED)

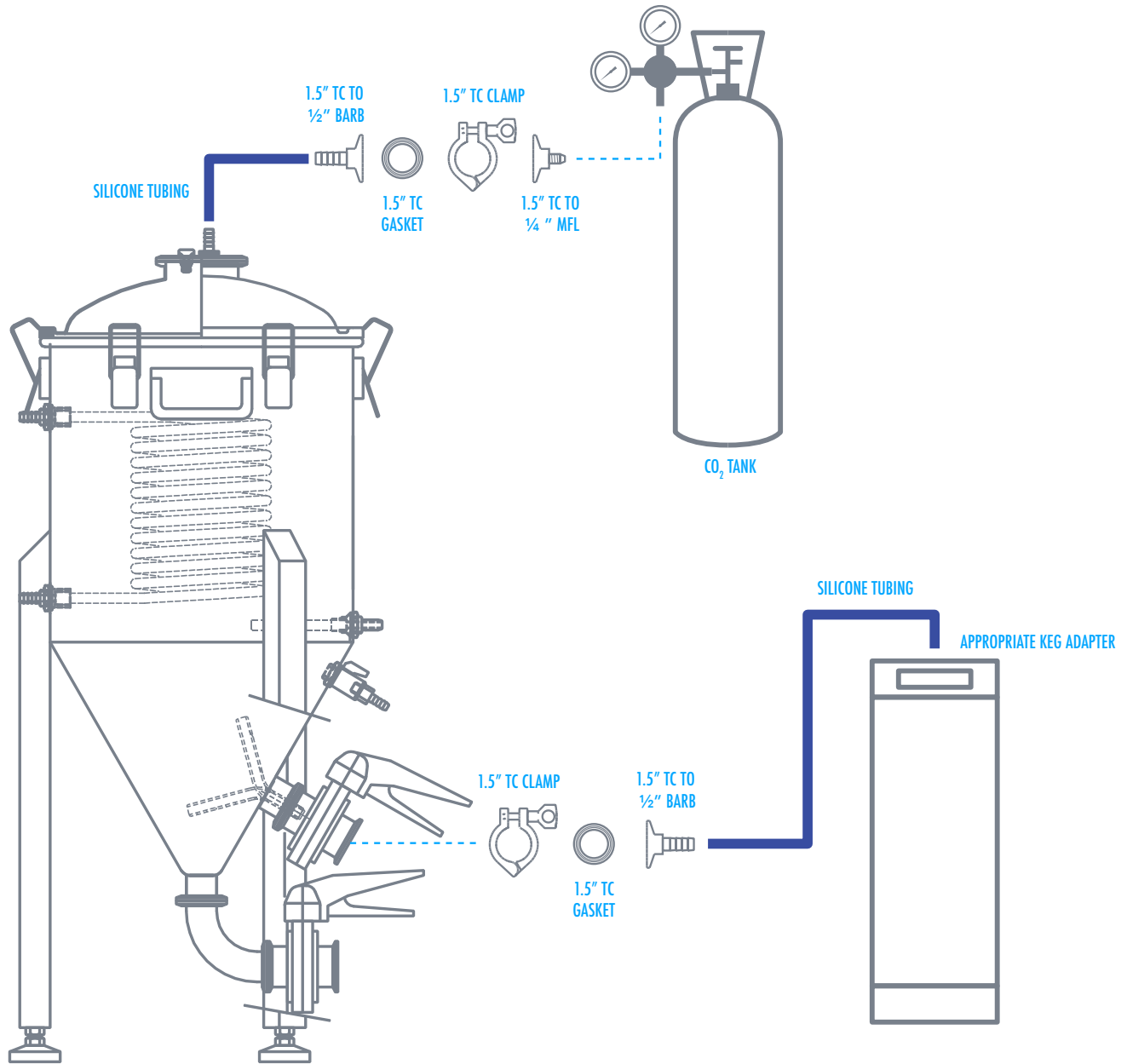

WARNING

Do not to exceed 2 PSI when transferring

NOTE

- USE HOSE CLAMPS ON ALL BARB FITTINGS
USE TEFLON TAPE ON ALL THREADED FITTINGS -

UNITANK CARB STONE METHOD

For ease of use, applying pressure of 2psi to your Unitank carb stone (plus the wetting pressure of your individual carb stone of up to 5psi) will apply enough pressure to your carbonated beer tank for pressure transfers. Simply attach your CO₂ line to your carbonation stone, open the carb stone valve, let your head pressure rise on the pressure gauge, and open your transfer/racking valve.

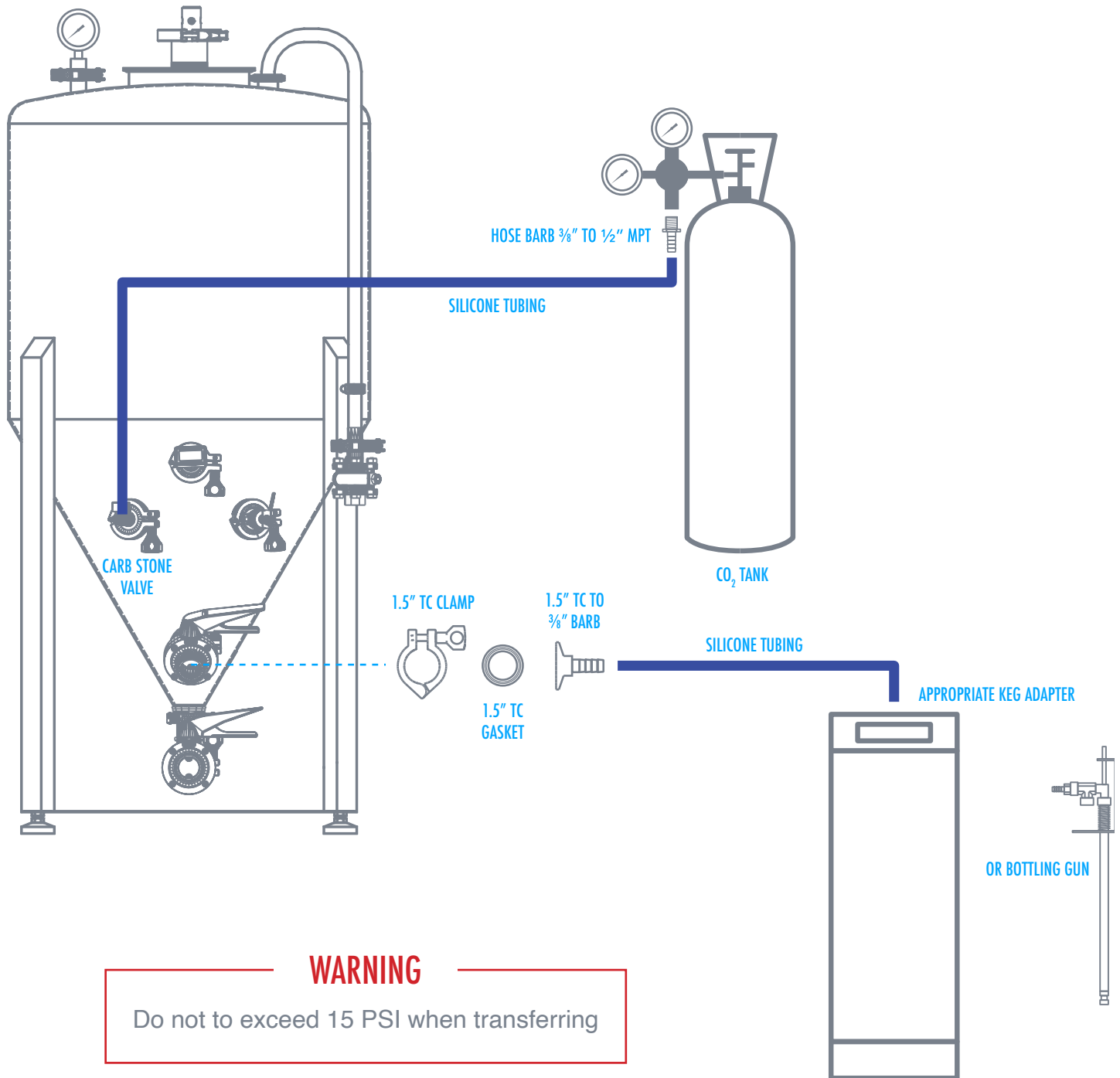

UNITANK BLOW-OFF ARM METHOD

On the Unitank, you can alternatively attach your CO₂ line on to the blow-off arm valve with a Hose Barb | 3/8" to 1/2" MPT. Using the same method as above you can open the blow off arm ball valve and apply your CO₂ line with 2psi of pressure to your Unitank head space. Simply attach your CO₂ line to your hose barb, open the blow off valve, let your head pressure rise on the pressure gauge, and open your transfer/racking valve.

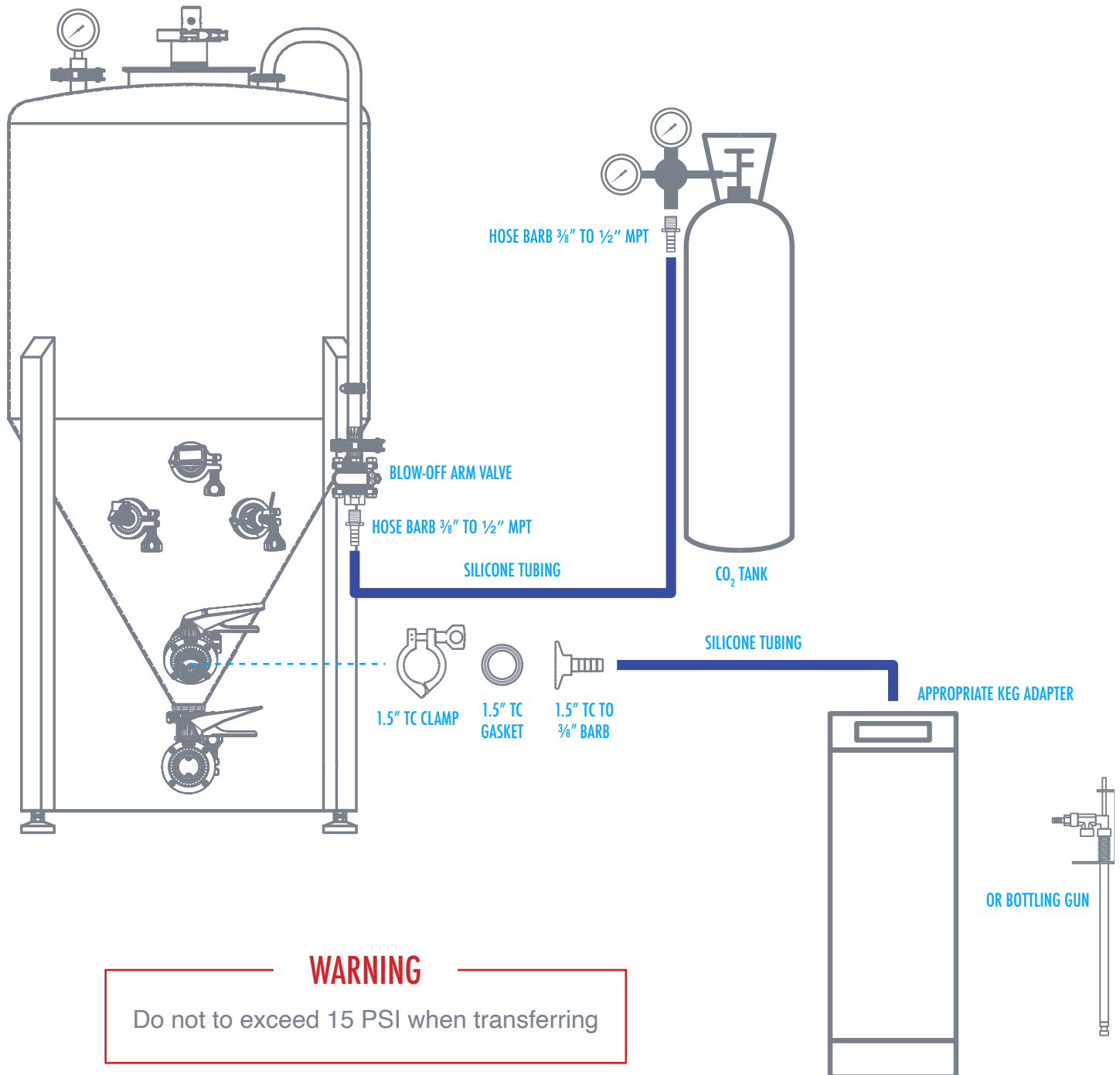

BRITE TANK CARB STONE METHOD

For ease of use, applying pressure of 2psi to your Brite tank carb stone (plus the wetting pressure of your individual carb stone of up to 5psi) will apply enough pressure to your carbonated beer tank for pressure transfers. Simply attach your CO₂ line to your carbonation stone, open the carb stone valve, let your head pressure rise on the pressure gauge, and open your transfer/racking valve.

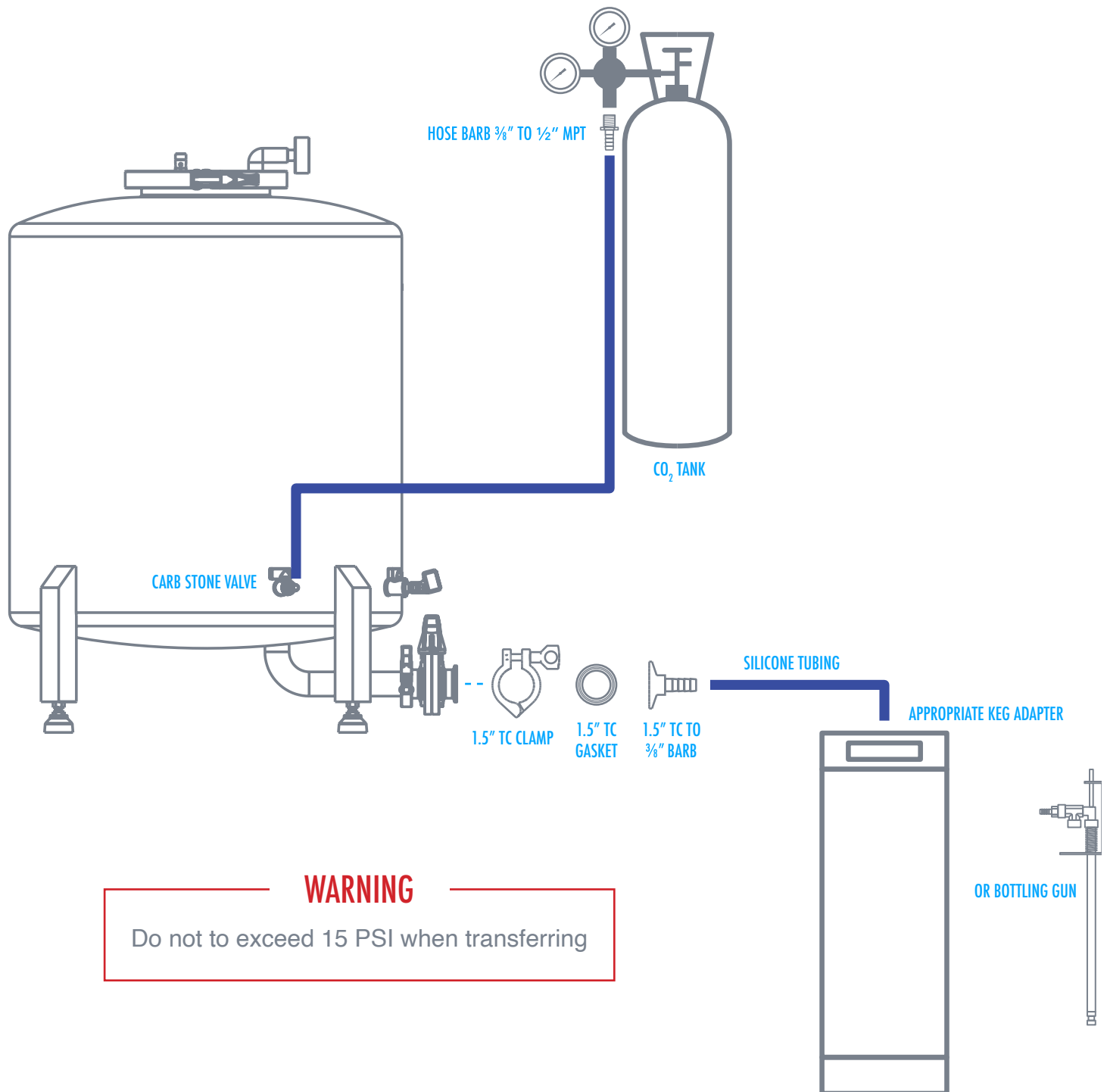

BRITE TANK (STANDARD) – ALTERNATIVE “TEE” METHOD

If you do not want to pressurize through the carb stone, you can add a tee fitting where the PRV is installed. A ¼” tee with a single male + two female ports AND a ¼” threaded hose barb will be needed. This would allow you to thread the tee into the cap, keep the Ss PRV in use, while also adding a valve barb to apply head pressure through the top.

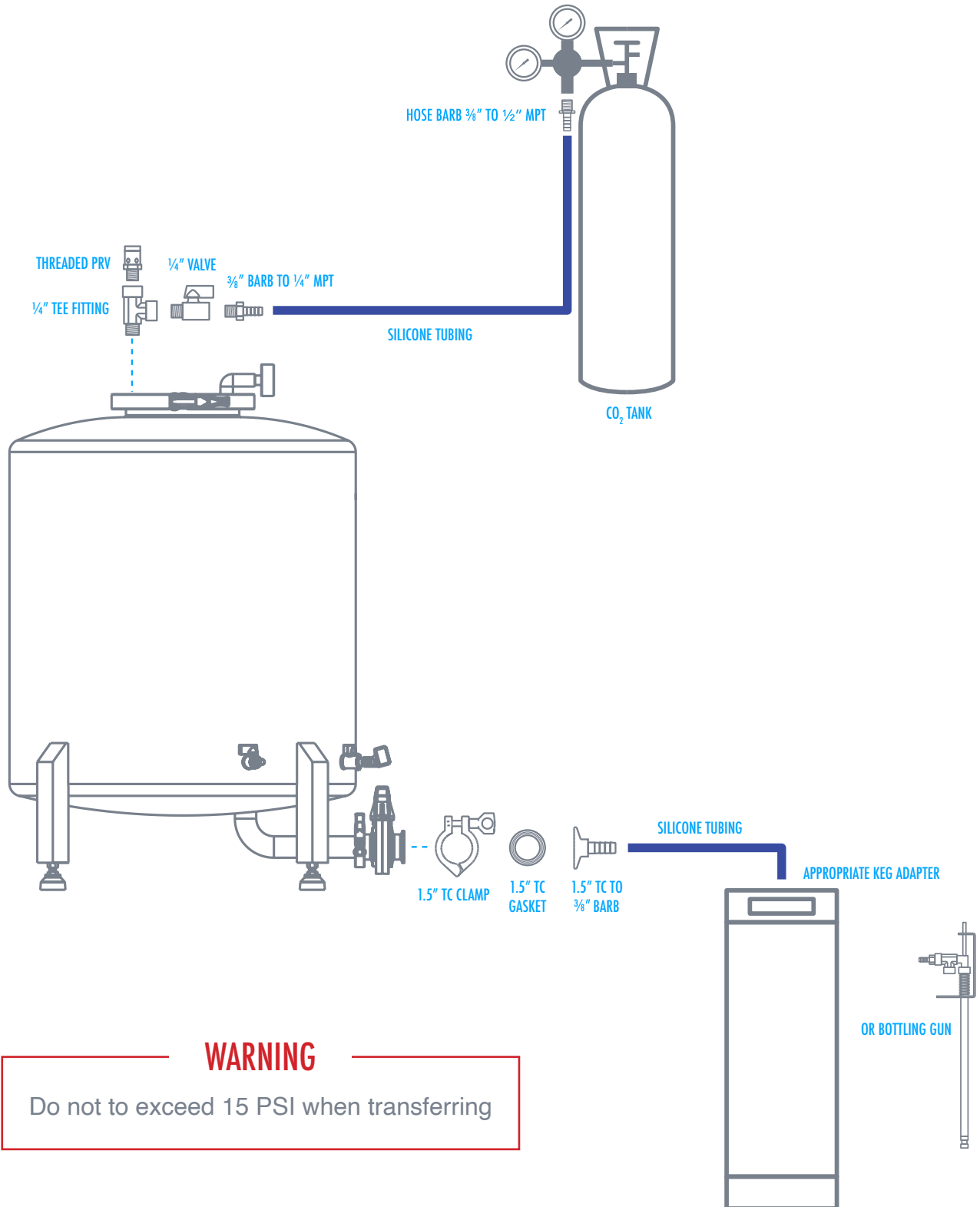

WARNING

Do not to exceed 15 PSI when transferring

BRITE TANK (BME) – ALTERNATIVE “TEE” METHOD

If you do not want to pressurize through the carb stone, you can add a TC tee fitting where the PRV is installed. You would need the following:

- (1) Tee I Micro 1.5” TC
- (2) additional 1.5” TC Gaskets
- (2) additional 1.5” TC Clamps
- (1) Ball Valve 1.5” TC to ½” Female NPT
- (1) Hose Barb I ⅜ to ½” MPT.

This would allow you to clamp the tee into the cap, keep the Ss 1.5” TC PRV in use, while also adding a valve with barb to apply head pressure through the top.

You can then apply your CO₂ line to your Brite tank BME head space. To do this, simply attach your CO₂ line to your valve’s hose barb, open this blow off valve, apply 2psi of pressure, let your head pressure rise on the pressure gauge, and open your transfer/center drain valve.

PRESSURE TRANSFER / KEGGING

BRITE TANK (BME) – ALTERNATIVE “TEE” METHOD (CONTINUED)

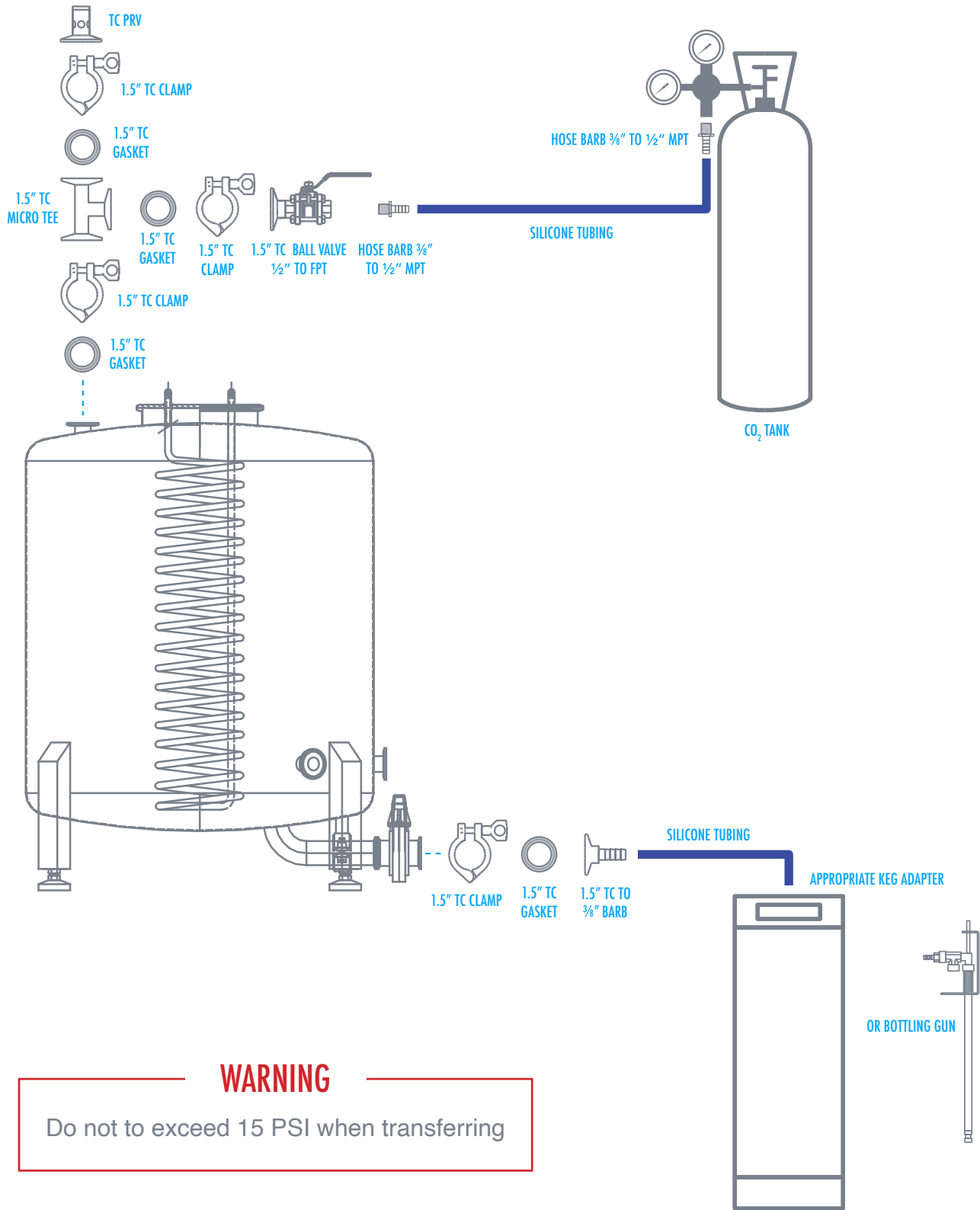

WARNING

Do not to exceed 15 PSI when transferring

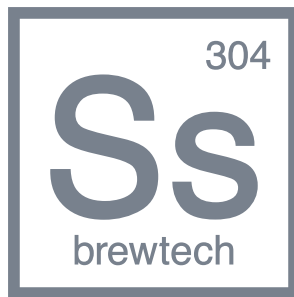

SsBrewtech.com