



Vent-Axia[®]

Award winning global ventilation company

Product Selector

Vent-Axia Australia First Edition

www.vent-axia.com.au

Now being distributed by Ventair

Vent-Axia has been active for over 80 years in supplying ventilation solutions to countries around the world, whose building regulations demand the most effective, sustainable and energy efficient ventilation solutions.

Ventair are now bringing these solutions to Australia.

Vent-Axia facilities

Crawley - Unitary plastic fan manufacture

- Our largest total manufacturing and office space with over 230,000 sq. ft. housing the Vent-Axia Head Office
- Manufacturing and warehouse space totals 108,000 sq. ft.
- Manufacture of plastic ventilation ranges
- Design and test facilities for rigorous product testing including safety, airflow and climate chambers - BEAB approved
- Head Office functions including Sales Office, Customer Services, Technical Support and Marketing

Reading - Plastic Moulding and extrusion manufacture

- State of the art production facility
- Injection and extrusion factory running 24 hours a day
- Over 30 injection moulding machines
- 5 extrusion lines for rigid and flexible duct

Dudley - Systems and Industrial manufacture

- 120,000 sq footage of manufacturing and warehousing space
- Manufacturing base for our metal products including Sentinel Demand Ventilation and Sentinel Totus
- Also the home of our heat recovery (MVHR) and Multivent (MEV) products

Sound Levels

Vent-Axia has a state of the art sound testing facility at Crawley (UK) providing sound power levels for comparison purposes tested in accordance with ISO 13347-1:2004 and ISO 13347-2:2004. This is an international standard that describes methods for determining sound power levels of fans in one-third octave bandwidths to allow comparisons to be made between different products from different manufacturers in a fair and consistent manner.

The data is not intended to equal the sound power levels experienced in any specific installation but enable the customer to compare different products and make an informed decision on their requirements.

Each installation will use different building materials that can have an effect on how sound is absorbed and/or reflected. It is therefore very difficult to predict the exact sound power levels exhibited in any given installation.

Performance

Tested in Vent-Axia test laboratories, performance testing is carried out in a balanced chamber test duct to BS 848: Part 1. This has a booster fan to overcome the system resistance.

The volume flow is measured by a pressure drop across a calibrated orifice plate at the entry to the system.



An adjustable damper provides a variable resistance to the test fan enabling its performance characteristics to be measured. Unless stated otherwise, the rated figures given are at free air performance.

BS EN ISO 9001/14001

Vent-Axia limited is certified by the British Standards Institution to BS EN ISO 9001 Cert. No. FM1792 QAS No. 3284/37, and BS EN ISO 14001 Cert. No. EMS600403.



Contents

	Lo-Carbon Svava Axial Bathroom/Toilet Fan	4 - 5
	Vent-Axia PureAir Sense Bathroom Fan/Toilet Fan	6 - 7
	Lo-Carbon Revive/SELV Bathroom/Toilet Fan	8 - 9
	Sentinel Kinetic Advance	10 - 13
	ACM 100-200 Mixed Flow Inline Fan	14 - 15
	ACM 250-315 Mixed Flow Inline Fan	16 - 17
	Acoustic Mixed Flow Inline Fan.	18 - 19



Lo-Carbon Svara

- Multiple installation and commissioning options
- Set up and control through the App via Bluetooth
- Continuous or intermittent
- Removable impeller for easier cleaning and replacement
- Silent hours scheduling and purge mode functions
- Intelligent light sensor with overrun timer - allows replacement of a basic model fan
- 3 Speed, IP44 Rated, DC motor with 5 year guarantee
- Suitable for ceiling, panel or wall mounting
- Only 17dB(A)
- Low running costs



Fully flexible installation and control

The launch of Svara marks the next generation of unitary fans. Home owners have complete control of their indoor air through an intuitive App designed to give them flexible options on how to run the fan. Giving home owners this control has the added benefit of removing the need for multiple returns to the property post installation should the fan not be set up quite to the householders' liking. For example the humidity setting being too sensitive. The home owner can simply log on to the App and change the setting themselves.

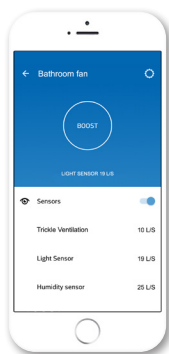

For electricians, installation is made simple through the App allowing you to choose intermittent or continuous ventilation; whether you would like the humidistat to trigger operation or not; and whether the overrun timer is required. No more fiddly switches and jumpers!



Aesthetics and Silence

The name Svara takes its influence from the fan's Swedish heritage - a country well known for iconic and well thought out designs. Consumers will be attracted to Svara's good looks with its sleek modern design, plus with noise a key issue for consumers, households will also be impressed by Svara's quiet running, operating at just 17dB(A) on low trickle. It is also easy to clean as the central module disconnects the motor from the rest of the fan allowing it to be simply wiped with a soft cloth, and at only 4W the energy efficient Svara also boasts low power consumption.

Multi Room Multi Function

Vent-Axia Svara is programmed to cope with the vast majority of installations. Because of this, it can be fitted in either a bathroom or Kitchen and can be set to run either continuously or intermittently.

Light Sensor

When the light sensor is enabled Svara senses when someone is in the room and then activates. Its sophisticated light sensor is triggered by light movement and shadows. It is possible to set a delay-on so the fan is not triggered by the light during quick night time bathroom visits. The light sensor can also distinguish between headlight flashes from cars and room occupancy, so it is not triggered by passing cars, avoiding nuisance running. The sensitivity of the light sensor can be adjusted via the App.

Overrun Timer

The light sensor provides an overrun timer but only requires a live and neutral. In houses where there is only a basic fan installed, the home owner can upgrade to a timer fan without having to rewire.

Humidistat

Svara features a humidistat which reacts to sharp changes in humidity, for instance when someone is taking a shower. When set to continuous running, once the humidity sensor is activated the fan runs at 30l/s until humidity returns to normal levels then the fan powers down to 10l/s. Ambient humidity changes will not trigger the humidistat. It is possible to change the sensitivity of the humidity sensor via the App.

Silent Scheduling and Automatic cycles

The silent hours scheduling function allows you to deactivate the boost function on the Svara via the App, for example, this would prevent nuisance noise over night. Additionally during a vacation you can set Svara to an airing mode which operates a purge function every 12 hours for either 30, 60 or 90 minutes depending on selection. However, Svara's sophisticated controls, will not purge if the light sensor detects that there is someone in the house.

Models

Svara kitchen and bathroom fan

100 mm Axial fan. Factory set at continuous running with Humidistat and Light Sensor/overrun timer On.

Model Stock Ref
Lo-Carbon Svara 409802

Accessories



Cover plate

For duct dimensions between Ø140-160mm

Model Stock Ref
Cover Plate 409820

Dimensions (mm)

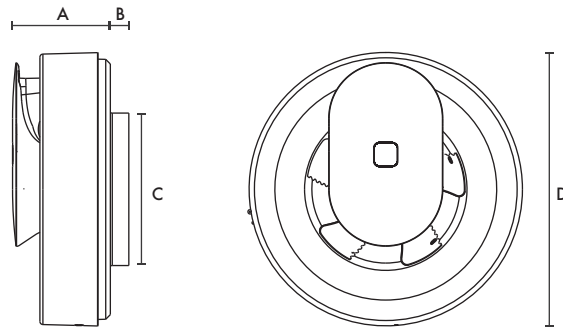

A	B	CØ	DØ
60	21	99	177

Performance Guide

Extract Performance - FID (l/s)				Sound dB(A)	SFP (W/l/s)
Low Trickle	High Trickle	Boost	Max Watts	@ 3m	@ 0Pa
10	16	30	4	17-20	0.13

Vent-Axia PureAir Sense

- Automatic odour sensor
- 7 year warranty
- LED touch panel
- App connected
- Silent running, as low as 19dB(A)
- Low power consumption at 2.5W
- Interchangeable spigots for 100 or 125mm installations
- Easy clean with removable impeller
- Optional magnetic front cover
- IP44 rated



Odour Sensor

The Vent-Axia PureAir Sense is Australia's first bathroom fan with Odour Sense Technology. This technology works by detecting unwanted odours in the air and triggers a purge function to clear the air. This results in a fresh bathroom without the need to add any harmful air sprays into the atmosphere.

Silent Operation

Running from just 19dB(A), the PureAir Sense is whisper quiet. Its silent continuous operation enables the fan to keep the air quality in the room high, without disturbing the occupants.

Humidity Control

The Vent-Axia PureAir Sense features an intelligent, fully automatic humidity sensor for moisture control. The fan will boost when it senses an increase in the room's humidity, ensuring the humid air is extracted and the room remains free of condensation. The fan continually monitors the environment and records the moisture content to allow it to map the humidity profile throughout the year. This process enables the fan to ensure that it runs only when the fan can lower the moisture content in the air. This reduces nuisance running and stops the fan from boosting unnecessarily, keeping running costs down.

Touch Panel

The front of the fan includes an intuitive, easy to use LED touch panel. Users can see which fan function is active by viewing the multicoloured LED indicator, as well as customising the fan's functions and boost speeds using the touch menu. For full description on the touch panel, please refer to the Instruction Manual provided with the fan.

Vent-Axia Connect App

All fan settings can be customised by downloading the Vent-Axia Connect App to Android and IOS devices.



Magnetic Front Cover

For the first time in any Vent-Axia product, a magnetic front cover is included with this fan. The cover is as simple as it sounds to put on with the use of four small magnets, and is designed to allow the fan to compliment any bathroom.



Adjustable Timer

The adjustable overrun timer operates automatically when installed, but can be customised using the Vent-Axia Connect App. The control panel can be used to easily set the required post-running time at 15 or 30 minutes, depending on your choice.

Cleaning and Maintenance

For a fan to ventilate effectively, it is vital that it is kept clean so that the ductwork and grilles are free from dust which can reduce the air flow. The removable impeller helps to simplify cleaning.

Automatic Airing Function

The airing function activates when the fan has been inactive for 26 hours. It runs an airing programme for 60 minutes to exchange the air in the bathroom. No more worries about stuffy, musty odours in the bathroom when returning home from time away.

Models

Vent-Axia PureAir Sense

Odour Sensing fan with intelligent humidistat, adjustable timer, intermittent or continuous settings and bluetooth app control.

Model Stock Ref
 PureAir Sense 479460



Wall Mounting Back Plate

Designed to cover up marks where a previous fan has a different foot print. 242mm x 190mm.

Model Stock Ref
 Wall Mounting Back Plate 406762

Dimensions (mm)

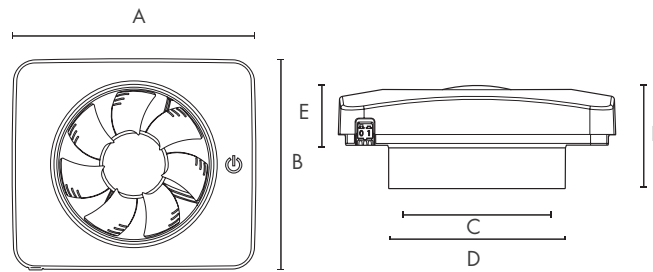

A	B	CØ	DØ	E	F
185	160	98	118	40	69

Product is supplied with a removable spigot 30mm deep for 100mmØ and 125mmØ applications. Weight 1.75kg

Performance Guide

Duct Ø	Boost/Continuous	Extract Performance - FID		Sound dB(A)	
		m ³ /h	l/s	@ 3m	Watts
100mm	Max	115	32	44	5
100mm	Continuous	36	10	21	2
125mm	Max	140	39	49	5
125mm	Continuous	54	15	23	2

19dB(A) at 8l/s selectable via App

Revive/SELV

- Designed for ventilation of any property and to protect rental houses
- Continuous running or intermittent operation for any room
- Extracts up to 60l/s for kitchens, bathrooms or laundries
- 7 year warranty
- High performance on trickle to avoid going to boost too often
- Intelligent Smart Sense™ technology tells you days run, boost hours run, energy used
- Innovative Multi-Vortex technology ensures high performance but low sound and energy levels
- Small footprint with optional decoration frame to install over an existing 150mm hole
- Unique settings lock to prevent tampering



Designed for rental properties

The award winning, intelligent Lo-Carbon Revive is a new filter-less unitary fan designed to meet the specific needs of rental properties. Boasting powerful, quiet, efficient ventilation, Revive provides good indoor air quality and comfort for residents while being quick and easy to install, low maintenance and reliable.

Smart Sense™ Technology

Featuring Smart Sense™ intelligent technology Revive is quick and easy to install due to its simple alpha numeric LED display which is clear, easy to read and has a three-button menu for commissioning and data gathering. Smart Sense™ technology even tells the LED display which orientation to use depending on whether it is wall or ceiling mounted. All of which saves time on site and reduces installation complications. The Revive is the only fan in the market with a unique setting lock to prevent tampering with the unit giving the landlords peace of mind.

The display also shows real-time data so landlords can reassure residents of the low-running costs. This includes data such as days run, hours on trickle or boost, and even more specifically, hours run on boost triggered by the humidity sensor. Revive can also tell you how much energy the fan has used.

Multi-Vortex™ Technology

Revive is low maintenance since its market-leading Multi-Vortex™ technology does not require a filter, while the highly sculpted interior actively repels dust, avoiding clogging, thus helping to avoid call backs. In addition the Multi-Vortex™ technology has a high-pressure hybrid impeller that is powerful and efficient, yet quiet – everything you need for the Social Housing resident.

Multiple configuration options

Revive can extract up to 60l/s from a kitchen - just two fans can exceed Part F rates for a 4-bed house. Upon installation you have the choice to change the setting to allow for installation in a bathroom. The installer can also select a ducted mode or a through the wall mode. All selected via the intuitive LED display.

Models



Revive 7/SELV 7

A universal kitchen or bathroom HTP fan with options to be continuous running or intermittent. Adjustable trickle speed between 6-13l/s and boost speeds of 15, 30 and 60. Day logger and power run meter as standard. 7 year warranty. Built-in lock function. Adjustable dynamic ambient response humidity sensor. Timer adjustable between 1 and 30 minutes. In built boost activated by pullcord, humidity sensor, switched live or remote button. Tile front for discreet installation.

Model	Stock Ref
Lo-Carbon Revive 7	473848
Lo-Carbon Revive SELV 7	473849

Model	Stock Ref
Lo-Carbon Revive	473852
Lo-Carbon Revive SELV	473853

Accessories

Model	Stock Ref
Conversion Kit	408680
Ceiling Kit	407928
Window Kit	407927
Decoration Frame	474041

Dimensions (mm)

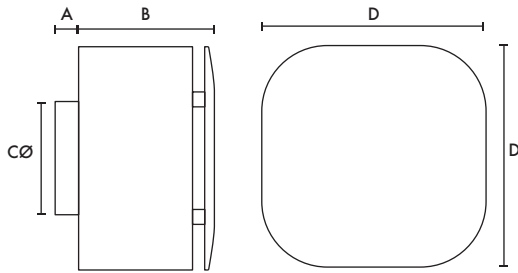

A	B*	C	D
30	132/102	99	193

*Closed/Open Grille

Decoration Frame Dimensions (mm)

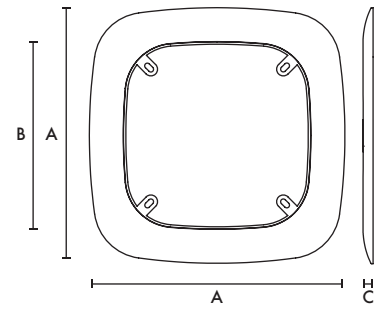

A	B	C
259	191	10

Performance Guide

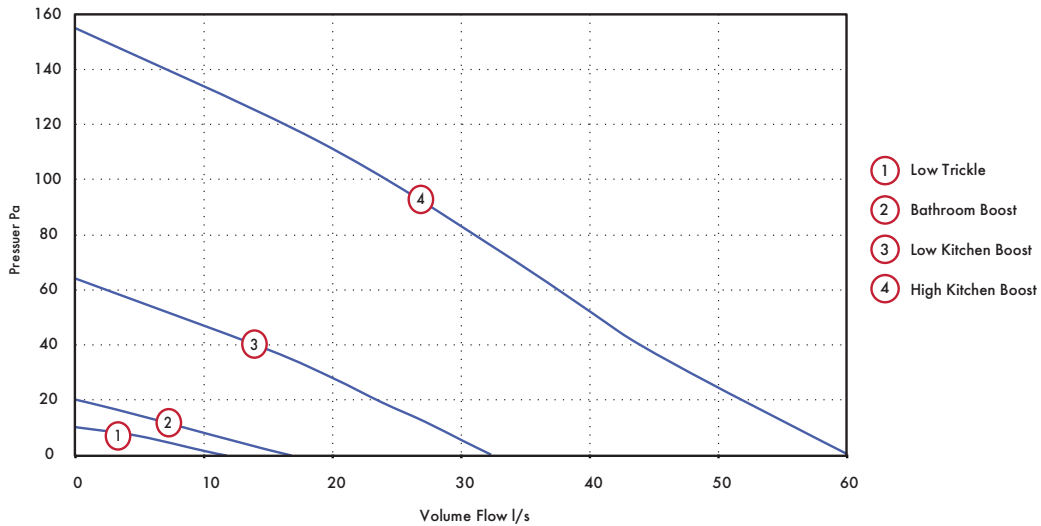

Model	Extract Performance (l/s)				Power Consumption (Watts)				Sound Data (dB(A))			
	Trickle Low	Bathroom Boost	Low Kitchen Boost	High Kitchen Boost	Trickle Low	Bathroom Boost	Low Kitchen Boost	High Kitchen Boost	Trickle Low	Bathroom Boost	Low Kitchen Boost	High Kitchen Boost
Revive	9	15	30	60	1.4	2	6	26	15	21	33	47

Sentinel Kinetic Advance

- Touch screen controller
- Lightweight for easier installation
- Full summer bypass
- Wi-Fi connectivity option
- Wireless commissioning
- Pre-commissioning via USB
- App control option
- Left/right handing through the controller
- Ultra low noise levels
- Australian model for tropical high humidity areas with an enthalpy energy recovery cell
- ISO ePM2.5 filters as standard



The award winning Sentinel Kinetic[®] Advance from Vent-Axia is the next generation of enthalpy energy ventilation systems. It is designed to offer the highest level of comfort and control available ensuring the best possible customer experience.

A whole new experience

The highly sculpted interior surfaces, designed using the latest CFD techniques, ensures airflows are maximised through the unit, minimising noise and energy use. This feature alone provides an experience which we are confident will delight home owners and fulfil our ambition of providing the most discrete and efficient ventilation available.

With the widest range of options available, installers can now order a system that is tailored to their client's needs.

Air Quality and Health

We have strived to make the Advance system the most flexible solution available on the market. Optimisation has been targeted in every aspect of the design to ensure that it really does improve quality of life. Whatever the outside environment, we have a method to help reduce air pollution from entering the living space. With the standard filter offering ISO ePM2.5 (F7) levels of filtration, even homes in heavily urbanised areas have the opportunity to filter out the impurities and help protect their family from respiratory issues.

Low noise levels

The most common concern with home owners is that ventilation devices create noise. With Advance, absolute optimisation of every element does everything possible to minimise generation and transmission of both motor and airflow noise. We believe that we have one of the quietest units available.

Ventilation how you want it

We have spent our time considering every element of the ventilation control. Should you want to run the system at certain times and at certain speeds, all of the options are available for you. With a programmable controller, it is possible to boost the unit if required, for example during hot periods in the summer, or even reduce the speed if needed, perhaps when a baby is due to go to bed. Whatever the situation, Advance can be made to operate as needed.

At the same time, automatic functions such as the summer bypass even have a choice of algorithms designed to suit different climates and lifestyles.

Controllability

With building services often hidden away in cupboards or in lofts we have developed a number of options for system control. From an App which provides instant access wherever you are, to full on-board touch screen controls, an option will be available to suit your needs.



SEC Class

Model	SEC Class
Advance S/SX	A+

Model
Model
Advance S

Stock Ref
479155

Accessories

Model
Wifi Controller
Docking Kit for Wired Controller

Stock Ref
409195
474491

Spare Filters

Model
ISO ePM2.5 70% (F7) (1 Pack)

Stock Ref
472671

Spigot Configuration

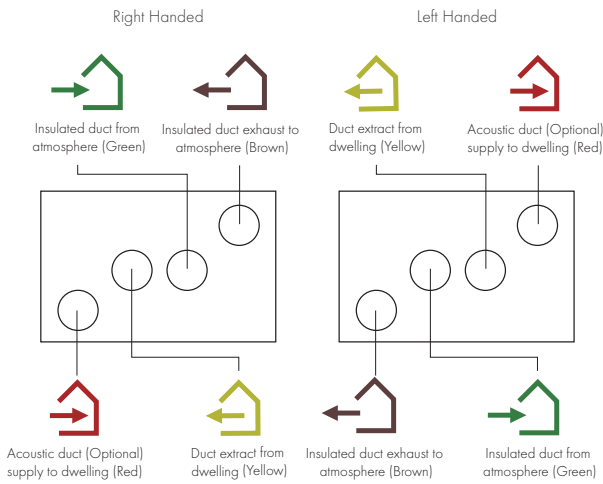

Hand-able through controller (except if pre-heater fitted)

Model Range Overview

Models	Advance S
Sentinel Touch Screen Controller	✓
App Control	○
App Commissioning	○
Auto Summer Bypass	✓
Easy Access Filters	✓
ISO ePM2.5 70% Filter	✓
Very Low Noise Levels	✓
Built-In Humidistat	✓
Active Frost Protection to -20°C	✓
Delay-On	✓
Clean Filter Indicator (Time)	✓
Fault Code Indicator	✓
Switched Live	✓
Volt Free	✓
Lightweight	✓
22mm or 32mm Condensate Connection	✓
Left/Right Orientation Through Control	✓
PIN Number Lock	✓
Running Time Indicator	✓
Enthalpy Heater Exchanger	✓
Fan Curve Flow	✓
Soft-Start Boost	✓

Mounting Options

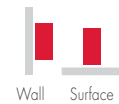

○ - Optional extra. Contact us for more information.

Dimensions (mm)
Unit

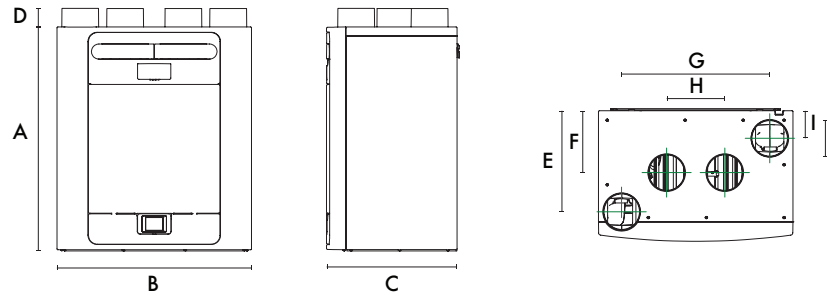

A	B	C	D	E	F	G	H	I	J	kg
760	660	443	63	343	210	503	197	93	125	27

Packed weight: 32kg

Performance

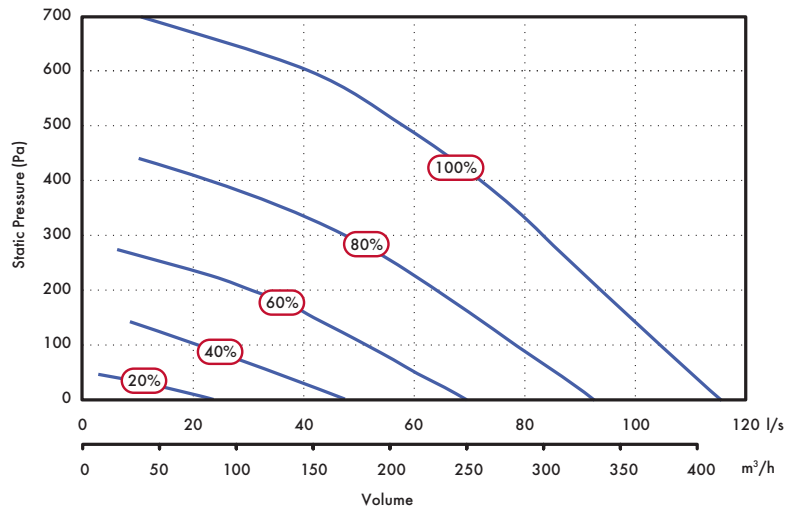

Sound Spectrum (Unit only)

Speed	Test mode	Octave Band (Hz) Sound Power Levels, dB								LwA	SPL dB(A) @ 3m
		63	125	250	500	1k	2k	4k	8k		
20%	Supply	52.9	50.9	46.8	43.0	34.6	27.1	19.2	25.4	43.9	26.4
	Extract	50.3	49.0	36.0	31.5	23.6	16.1	18.9	25.3	36.4	18.9
	Breakout	34.6	34.8	35.7	34.9	29.6	25.1	21.0	25.3	36.0	15.5
40%	Supply	59.5	56.5	59.4	55.0	48.2	42.6	31.8	26.1	55.9	38.4
	Extract	51.9	51.3	50.4	41.2	35.0	25.3	19.8	25.4	44.8	27.3
	Breakout	40.2	42.6	46.5	45.4	41.0	36.2	25.5	25.3	46.5	26.0
60%	Supply	66.9	62.4	63.3	62.0	57.9	53.5	43.4	34.2	63.2	45.7
	Extract	60.6	60.3	54.2	49.5	44.4	36.2	27.9	26.3	51.7	34.2
	Breakout	45.5	49.8	52.5	53.1	49.7	46.7	36.2	26.9	54.5	34.0
80%	Supply	82.4	67.6	65.2	67.6	64.2	60.8	50.8	43.2	69.2	51.7
	Extract	75.5	68.6	59.3	56.0	48.3	44.2	36.9	31.3	58.6	41.1
	Breakout	59.2	55.0	56.8	60.0	55.4	53.9	44.1	33.4	61.0	40.5
100%	Supply	79.4	69.6	66.6	75.1	64.9	63.6	53.4	45.7	73.7	56.2
	Extract	72.4	70.5	60.5	56.4	49.8	46.3	39.0	33.4	59.5	42.0
	Breakout	63.0	57.1	58.5	63.7	56.8	55.9	46.4	36.2	63.5	43.0

Tested according to BS EN 13141-7:2010. Breakout quoted spherical. Supply and Extract quoted hemispherical. For in-duct data, end reflections are added based on the spigot size of the unit.

Consultant's Specification

Specification

The supply and extract ventilation unit shall be the Sentinel Kinetic Advance as manufactured by Vent-Axia and shall be sized as indicated on the drawings and shall be in accordance with the particular specification.

The unit shall be fully insulated for thermal and acoustic performance and shall incorporate a counterflow multiplate heat exchanger with independently verified thermal efficiency up to 93%. The heat exchanger shall be protected by ISO ePM2.5 (F7) filters. The filters shall be accessible via tool-free access doors. The heat exchanger, motors, summer bypass and all other serviceable parts shall be accessible through the front of the unit.

Supply air to the room shall be pre-heated by the extract air via the integrated composite plastic counter-flow heat recovery cell. The Sentinel Kinetic shall automatically vary the ventilation rate via EC/DC motors, as it receives signals from optional or in-built sensor inputs. When a signal is received, the fans shall either vary their speed proportionally or on a trickle/boost principle.

The unit shall have the facility to commission the supply and extract fans individually via in-built minimum and maximum speed adjustment, or alternative wired remote control unit. The fans themselves shall have independent, infinitely variable speed control.

Unit Specification

The unit shall be manufactured with an ABS Outer case construction, with the ability to alter the spigot configuration via the on-board controller. The unit shall have a high efficiency composite plastic counter-flow heat exchanger, supply and extract filters (ISO ePM2.5 (F7)), automatic 100% summer bypass, integral minimum and maximum infinitely variable speed controls with fascia mounted failure indication.

The unit shall have low energy, high efficiency EC/DC fan/motor assemblies with sealed for life bearings. The impellers shall be high efficiency backward curved centrifugal type, achieving an SFP as low as 0.38W/l/s (EN 308).

The unit shall have a heat exchanger cell with a thermal efficiency of up to 93% when tested to EN 308. This shall be protected by ISO ePM2.5 (F7) filters. The unit shall come with both a 22mm and 32mm connection for draining condensation.

The unit shall be constructed with a removable tool-free front panel which gives access to the removable on-board controller and other accessories. The EPS panel can then be removed with 4 screws allowing full maintenance access. This shall provide access to the following:

- ✓ Supply or extract fan
- ✓ Heat exchanger
- ✓ Access to the electrical connections

Access shall be provided for wiring termination and setup/commissioning. The backlit touch-screen user interface therein shall be removable for remote mounting if required. Filters shall be accessed via the two pull out drawers near the top of the unit.

Units shall be as manufactured by Vent-Axia Ltd.

Standard Controls

The Sentinel Kinetic Advance shall incorporate the following functions integrally mounted through a touch-screen, adjustable controller fitted by the manufacturer: -

- ✓ Integral infinitely variable fan speed control on supply and extract.
- ✓ 6 speeds; 4 adjustable
- ✓ Left or Right hand spigot configuration, programmable by the on board controller
- ✓ Filter change wizard which stops the motors during filter replacement
- ✓ Volt free contacts
- ✓ 24V external sensor supply, eg PIR sensor
- ✓ Filter check facility adjustable in one month increments

The unit shall incorporate:

- ✓ An integral humidity sensor with the following features:
 - Ambient Response; Raises the humidity trigger point as dwelling temperature reduces.
- ✓ Rapid Response: Monitors the rate of change in humidity and triggers increased airflow even if the humidity trigger threshold is not reached.
- ✓ Proportional Response; incrementally increases the fan speed to reduce noise and reduce energy consumption.
- ✓ WiFi connectivity for remote commissioning
- ✓ USB functionality for commissioning
- ✓ The unit shall incorporate an automatic 100% summer bypass damper which monitors internal and external temperatures to maintain the user comfort temperature (default 21°C) :
 - 'Evening Fresh' turns the unit to maximum speed with the bypass operational for 2 hours or until the user comfort temperature is reached (default 21°C).
 - 'Night Time Fresh' will run the unit on maximum speed with the bypass operational throughout the night or until the dwelling reaches minimum temperature (default 14°C).

Independently acoustically tested to BS EN 13141-7:2010

Electrical Connection

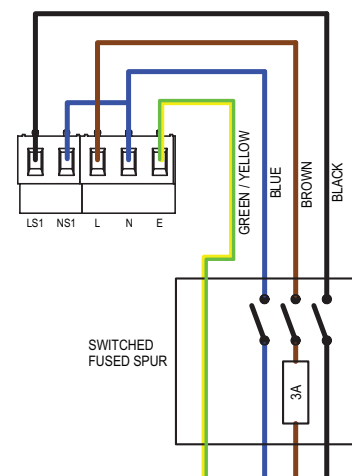

ACM 100-200

- Designed for rugged reliability
- Three speed motor
- Timer versions available
- Removable motor core
- Rotating motor chassis
- IP44 rated
- Aesthetically pleasing with wipe clean polymer casing
- Sound data from independent testing
- Running speed selected on installation



Ducted Ventilation

Vent-Axia has designed a complete range of energy efficient Mixed Flow In-Line fans that are now quieter, offer two and half times the pressure of conventional axial fans and are dimensionally more compact making them ideal for many ducted applications.

The ACM Mixed Flow In-Line fan can operate in both horizontal and vertical positions.

Motor

All motors have three speeds selectable on installation and are fitted with Standard Thermal Overload Protection (S.T.O.P.). Designed for ambient temperatures up to +50°C. All sizes with capacitor run motors. All sizes are Class II appliances. Supply voltage 220-240V/1/50Hz.

Installation

These units have a separate footplate for simple location mounting and detachable spigots for simple connection to ducting. The motor body chassis rotates to provide connection in acute spaces. Cleaning the product is simple as all parts can be removed without removing the ducting.

Models

Model	Stock Ref
ACM100	17104010
ACM100T	17104020
ACM125	17105010
ACM125T	17105020
ACM150	17106010
ACM150T	17106020
ACM200	17108010
ACM200T	17108020

Dimensions (mm)

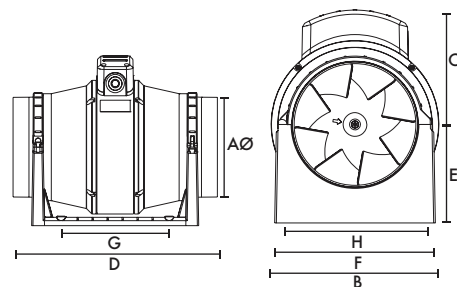

Size	100	125	150	200
AØ	97	122	147	199.5
B	178	178	200	223
C	124	124	138	146
D	298	259	350	300
E	96	96	118	130
F	168	168	192	195
G (fixing hole)	120	120	162	100
H (fixing hole)	153.5	153.5	178	180

Performance Guide

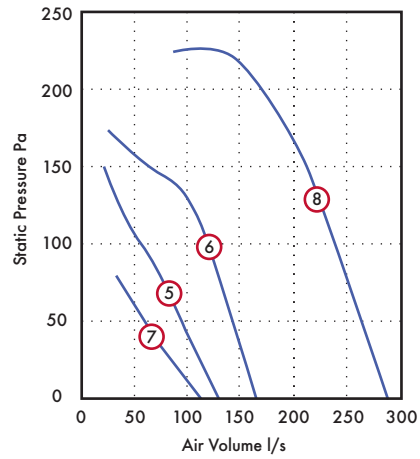
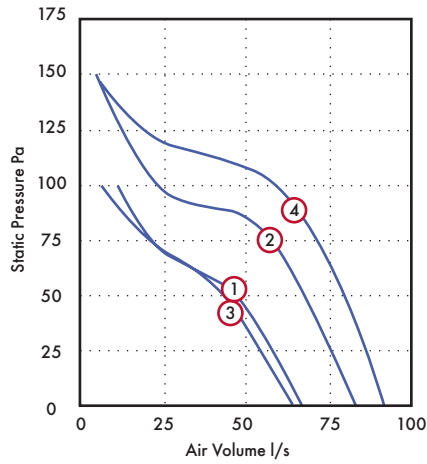

l/s @ Pa

Dia.	Motor Phase	Speed	r.p.m	IP Rating	Curve Ref.	0	50	100	150	200	Motor kW	F.L.C Amps	dB(A) @ 3m
100	1	Low	1580	IP44	1	70	50	10			0.02	0.09	16
100	1	High	2200	IP44	2	80	70	20			0.02	0.1	22
125	1	Low	1450	IP44	3	60	40	10			0.03	0.1	17
125	1	High	2400	IP44	4	90	80	60			0.02	0.12	24
150	1	Low	1645	IP44	5	130	90	60			0.04	0.17	29
150	1	High	2350	IP44	6	160	140	120	60		0.05	0.21	36
200	1	Low	1845	IP44	7	110	60				0.08	0.48	26
200	1	High	2350	IP44	8	290	260	240	210	170	0.11	0.55	41

*Medium speed is not shown.

Sound Data

Dia.	Spectrum	63	125	250	500	1k	2k	4k	8k	dB(A) @ 3m
100	Breakout High	32	36	41	39	37	37	28	22	22
100	Breakout Low	30	31	34	36	28	29	23	22	16
100	Inlet High	38	42	57	56	54	46	38	30	37
100	Inlet Low	35	40	49	49	47	37	28	24	30
100	Outlet High	36	41	52	52	53	44	37	28	34
100	Outlet Low	38	41	45	46	45	36	28	24	27
125	Breakout High	32	33	38	41	41	40	33	23	24
125	Breakout Low	27	33	30	39	30	29	24	22	17
125	Inlet High	36	47	53	58	55	53	47	39	39
125	Inlet Low	38	42	45	48	45	41	35	26	29
125	Outlet High	36	47	51	54	55	50	46	37	37
125	Outlet Low	33	41	45	45	44	38	33	25	26
150	Breakout High	26	28	41	45	48	54	41	29	36
150	Breakout Low	21	29	45	49	43	44	32	22	29
150	Inlet High	40	49	59	63	59	63	55	47	46
150	Inlet Low	38	46	52	57	52	54	46	37	38
150	Outlet High	36	48	54	60	58	61	54	46	44
150	Outlet Low	33	45	49	54	54	52	45	36	37
200	Breakout High	38	53	47	47	56	60	44	33	41
200	Breakout Low	26	46	40	34	30	26	18	21	26
200	Inlet High	46	52	54	60	61	63	60	49	47
200	Inlet Low	38	37	40	41	39	35	24	23	22
200	Outlet High	63	68	69	73	70	69	62	54	54
200	Outlet Low	53	54	52	52	48	47	39	28	33

ACM 250-315

- Available in two sizes
- Supplied complete for simple installation
- Optimise fan performance by using an approved Vent-Axia controller
- Diagonal impeller with stator
- Galvanized metal housing
- Integrated thermal switch
- Includes a mounting bracket
- Designed to meet IP54



Ducted Ventilation

Vent-Axia has designed a complete range of energy efficient Mixed Flow In-Line fans for use with rigid and flexible ducting.

In-line Mixed Flow fans offer two and half times the pressure of conventional axial fans and are dimensionally more compact making them ideal for many ducted applications.

The ACM Mixed Flow In-Line fan can operate in both horizontal and vertical positions and can be mounted to meet its optimum performance.

Motor

All motors are fitted with Standard Thermal Overload Protection (S.T.O.P.). Designed for ambient temperatures up to +50°C. All sizes with capacitor run motors. ACM 250 and 315 are Class I appliances. Supply voltage 220-240V/1/50Hz.

Models

Model	Stock Ref
ACM250	17110010
ACM315	17112010

ACM315 Controller

Used in conjunction with speed controllable fans to provide 5 stepped speed without electronic motor 'hum'. Several fans can be connected to one transformer provided their combined load does not exceed the controller rating.

Single phase: 3.0 amp. Rotary switch giving On/Off and five speeds.

Output voltages at 240V/1PH/50Hz 0, 90, 115, 140, 175, 240 volts.

Neon indicator. Enclosures are protected to IP54.

Dimensions: 135 x 170 x 117mm (H x W x D).

Model	Stock Ref
3A Transformer Controller	10314103

Dimensions (mm)

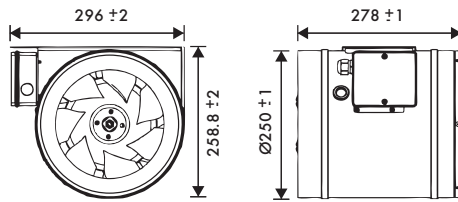

ACM250

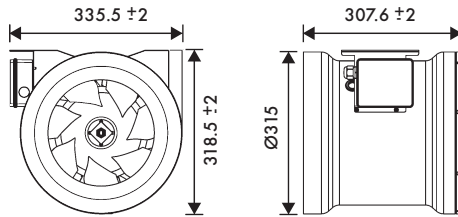

ACM315

Performance Guide

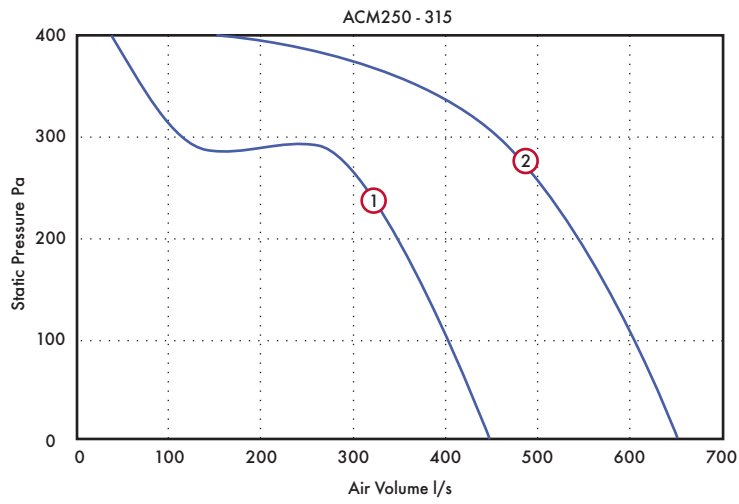

Dia.	Stock Ref.	Poles	r.p.m	IP Rating	Curve Ref.	l/s @ Pa					S.C. Amps	F.L.C Amps	dB(A) @ 3m
						0	100	200	300	400			
250	17110010	2	2720	IP54	1	450	410	350	120	40	0.8	1	53
315	17112010	2	2840	IP54	2	650	610	540	460	150	1.2	1.6	56

Sound Data

Dia.	Spectrum	dB(A) @ 3m							
		125	250	500	1k	2k	4k	8k	
250	Inlet	34	54	61	65	67	66	55	72
250	Outlet	39	64	68	71	70	66	55	78
250	Breakout	34	41	43	46	46	42	37	54
315	Inlet	45	60	66	68	69	67	56	75
315	Outlet	47	69	73	74	72	66	57	79
315	Breakout	38	41	46	50	49	46	41	58

Acoustic Mixed Flow Inline Fan

- High performance mixed flow fan - ideal for ducted applications
- Low noise operation
- Low energy EC motors
- Fully attenuated case
- Low profile design
- Rugged mounting foot design



Vent-Axia acoustic inline fan

The new acoustic inline fan from Vent-Axia is designed for quick and easy install to provided ultra-quiet ducted ventilation. Designed with inbuilt acoustic insulation which reduces noise whilst maintaining great airflow.

Long life, low energy motor

Fitted with an energy efficient, long life brushless EC motor, the fan is designed to minimise energy use whilst providing a long trouble-free life. With a free air volume of 80l/s at only 17watts the 150mm model has market leading performance.

Low noise

With sound levels as low as 28dBA its one of the quietest mixed flow fans available and offers a great solution where performance cannot be compromised, but low running noises are also required.

Models

Model
150mm
200mm

Stock Ref
ECSM150
ECSM200

Dimensions (mm)

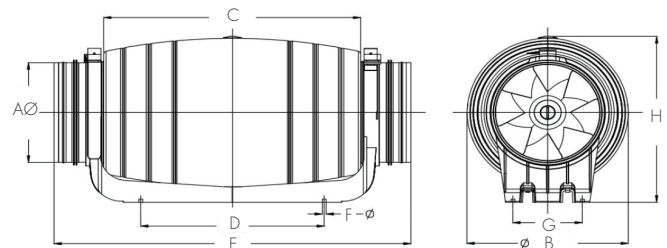

Size	150	200
AØ	149	198
BØ	221	262
C	352	436
D	251	339
E	488	567
FØ (fixing hole)	5.3	5.6
G	95	128
H	244	301

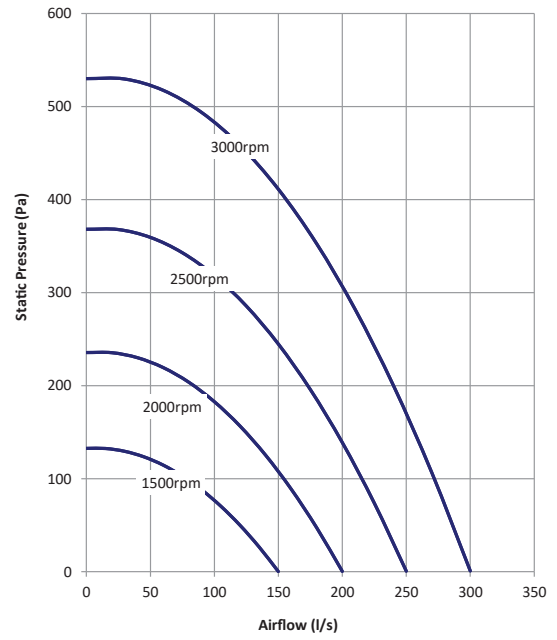
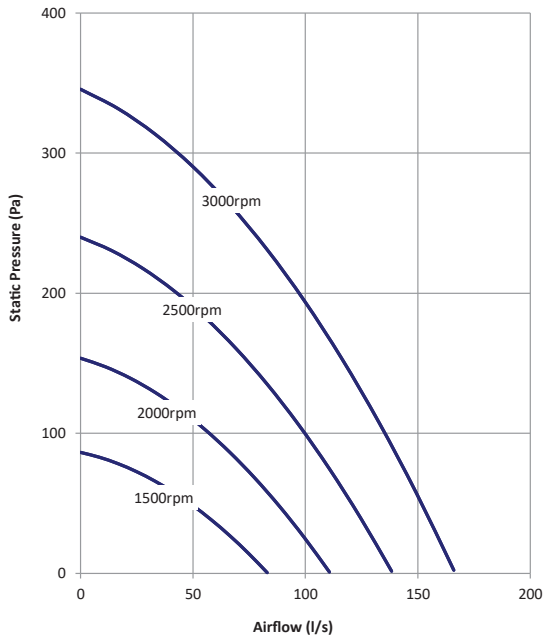

Sound Data

Dia.	r.p.m	IP Rating	Motor W	F.L.C Amps	dB(A) @ 3m
150	1500	IP44	17	0.1	28
150	2000	IP44	30	0.19	35
150	2500	IP44	54	0.36	40
150	3000	IP44	73	0.48	44
200	1500	IP44	38	0.23	36
200	2000	IP44	67	0.42	31
200	2500	IP44	120	0.78	45
200	3000	IP44	165	1.05	49

63	125	250	500	1k	2k	4k	8k
37	37	45	47	45	40	35	30
44	44	52	54	52	47	42	37
49	49	57	59	57	52	47	42
52	53	61	63	61	56	51	46
45	46	48	52	52	50	47	42
48	49	51	55	55	53	50	45
54	55	57	61	61	59	56	51
58	59	61	65	65	63	60	55

VENT-AXIA AUSTRALIA CONTACT NUMBERS

Free technical, installation and sale advice is available

Enquiries: 03 9775 0556
1300 665 926

Web: www.vent-axia.com.au
Email: info@vent-axia.com.au

Supply & Service

All sales made by Vent-Axia Limited are only upon terms of the Company's Conditions of Sale, a copy of which may be obtained on request. As part of the policy of continuous product improvement Vent-Axia reserves the right to alter specifications without notice.

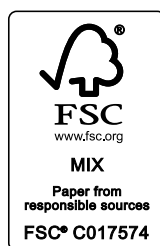

V1/1909

Distributed by **ventair**
THE AIR MOVEMENT SPECIALISTS