

Last modification 2022-12-06

ZAHA TL2-CHCR
9329501057667



Spheres of prismatic cut crystal bring contemporary glamour to the ZAHA collection. Each sphere is illuminated with a LED twinkle globe accentuating the cut surface. The family includes a 1 light pendant, 1 light wall lamp, 2 light table lamp, 4 light bar pendant, 5 light round pendant and 10 light round pendant. Available in Antique gold or chrome.

Overview

Family name	Zaha
Categories	Table Lamps
This item includes	Glass
Switch	Inline Switch
Usage	Indoor Lighting
ERAC Product Registration	SAA-210304-EA

Color / Material

Fixture Color	Clear,Chrome
Fixture Material	Iron,Crystal
Canopy Color	Chrome
Shade Color	Clear
Shade Material	Crystal
Base Color	Chrome
Base Material	Iron
Cable Color	Black
Cable Material	PVC

Size

Fixture Diameter (cm)	17.0
Fixture Height (cm)	50.0
Base Diameter (cm)	17.0
Base Height (cm)	39.5
Shade Diameter (cm)	11.0
Shade Height (cm)	9.0
Cable Length (cm)	180 (30+Inline Switch+150)

All representations within this document are subject to copyright. ELECTRICAL INSTALLATIONS MUST BE PERFORMED BY A QUALIFIED ELECTRICAL CONTRACTOR AND INSTALLED IN ACCORDANCE WITH AS/NZS 3000.
NOTE : All images , descriptions and dimensions are indicative. Please check latest version of item detail on Telbix website prior to ordering or installation.

Specification

Voltage Input	240V
Wattage (max)	6
Wattage	3
Globe Type	G9
Globe / Light Source qty	2
Globe / Light Source included	Yes
Color Temperature	Warm White
Color Kelvin	3000k
Color Rendering	>80
Dimmable	No
Electrical Protection	CLASS II - DOUBLE INSULATED, EARTH NOT REQUIRED
IP rating	IP20
Lead and Plug	Yes
Approvals	RCM
Assembly Required	Yes
Box Contents	Instruction
Care Instructions	Do not use strong liquid cleaners,Wipe clean with a dry cloth
Replacement Warranty	*3 Years

Barcode

GTIN 9329501057667

Image -dimensions

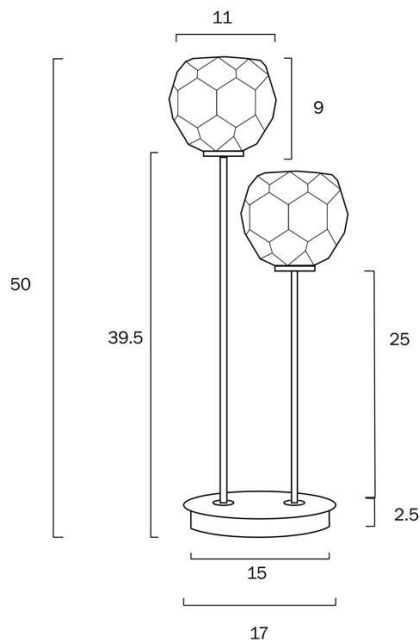





Last modification

2022-12-06

ZAHA TL2-AGCR
9329501057674



Spheres of prismatic cut crystal bring contemporary glamour to the ZAHA collection. Each sphere is illuminated with a LED twinkle globe accentuating the cut surface. The family includes a 1 light pendant, 1 light wall lamp, 2 light table lamp, 4 light bar pendant, 5 light round pendant and 10 light round pendant. Available in Antique gold or chrome.

Overview

Family name	Zaha
Categories	Table Lamps
This item includes	Glass
Switch	Inline Switch
Usage	Indoor Lighting
ERAC Product Registration	SAA-210304-EA

Color / Material

Fixture Color	Clear,Antique Gold
Fixture Material	Iron,Crystal
Canopy Color	Antique Gold
Shade Color	Clear
Shade Material	Crystal
Base Color	Antique Gold
Base Material	Iron
Cable Color	Black
Cable Material	PVC

Size

Fixture Diameter (cm)	17.0
Fixture Height (cm)	50.0
Base Diameter (cm)	17.0
Base Height (cm)	39.5
Shade Diameter (cm)	11.0
Shade Height (cm)	9.0
Cable Length (cm)	180 (30+Inline Switch+150)

All representations within this document are subject to copyright.ELECTRICAL INSTALLATIONS MUST BE PERFORMED BY A QUALIFIED ELECTRICAL CONTRACTOR AND INSTALLED IN ACCORDANCE WITH AS/NZS 3000.
NOTE : All images , descriptions and dimensions are indicative. Please check latest version of item detail on Telbix website prior to ordering or installation.

Specification

Voltage Input	240V
Wattage (max)	6
Wattage	3
Globe Type	G9
Globe / Light Source qty	2
Globe / Light Source included	Yes
Color Temperature	Warm White
Color Kelvin	3000k
Color Rendering	>80
Dimmable	No
Electrical Protection	CLASS II - DOUBLE INSULATED, EARTH NOT REQUIRED
IP rating	IP20
Lead and Plug	Yes
Approvals	RCM
Assembly Required	Yes
Box Contents	Instruction
Care Instructions	Do not use strong liquid cleaners,Wipe clean with a dry cloth
Replacement Warranty	*3 Years

Barcode

GTIN 9329501057674

Image -dimensions

