

Last modification 2024-04-06

COSCA EX145-WHFR 9329501066201



The Cosca Exterior Wall Lamp – is an exquisite fusion of functionality and aesthetics designed to elevate your outdoor space. Crafted to complement rustic, country, or modern façades, this lamp boasts a small arm and a downward-facing body with a wider bottom, adding a touch of sophistication to your exterior. Available in classic black with smoke glass or pristine white with frost glass, the Cosca comes in both small and large sizes, allowing you to customize your lighting experience. Illuminate your surroundings with style and grace – embrace the allure of the Cosca.

Overview

Family name	Cosca
Categories	Coach Lights
Mounting	Surface
Usage	Outdoor Lighting

Color / Material

Fixture Color	White
Fixture Finish	Sand
Fixture Material	Aluminium, Glass
Canopy Color	White
Glass Color	Frost

Size

Fixture Width (cm)	14.5
Fixture Height (cm)	26.0
Fixture Projection (cm)	14.0

Specification

Voltage Input	240V
Total Wattage (max)	25
Globe Type	E27
Globe / Light Source qty	1
Globe / Light Source included	No
Electrical Protection	CLASS I - HIGH VOLTAGE, EARTH REQUIRED
IP rating	IP43

All representations within this document are subject to copyright. ELECTRICAL INSTALLATIONS MUST BE PERFORMED BY A QUALIFIED ELECTRICAL CONTRACTOR AND INSTALLED IN ACCORDANCE WITH AS/NZS 3000.
NOTE : All images , descriptions and dimensions are indicative. Please check latest version of item detail on Telbix website prior to ordering or installation.

Lead and Plug	No
Approvals	RCM
Assembly Required	No
Installation Required	Yes (by Licensed Electrician only)
Care Instructions	Do not use strong liquid cleaners, Wipe clean with a dry cloth, Aluminium, Brass and Stainless Steel will naturally oxidised and change overtime. Exterior products require regular four (4) monthly cleaning and maintenance to ensure they do not accumulate dirt or other environmental deposits. Wipe the product with a mild detergent and warm water to remove surface deposits. Rinse with fresh water and wipe dry with a soft cloth. An extra temporary protection barrier of water displacement oil can help to maintain the surface, such as WD40, sprayed onto a soft cloth and rubbed onto the surface.
Replacement Warranty	*3 Years

Barcode

GTIN 9329501066201

Image -dimensions

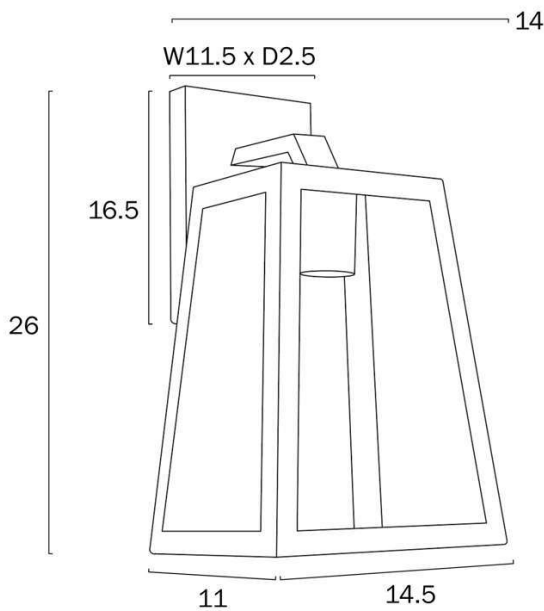

Note: Dimensions are only a guide and may vary due to manufacturing variations.

Last modification 2024-04-06

COSCA EX145-BKSM 9329501066195



The Cosca Exterior Wall Lamp – is an exquisite fusion of functionality and aesthetics designed to elevate your outdoor space. Crafted to complement rustic, country, or modern façades, this lamp boasts a small arm and a downward-facing body with a wider bottom, adding a touch of sophistication to your exterior. Available in classic black with smoke glass or pristine white with frost glass, the Cosca comes in both small and large sizes, allowing you to customize your lighting experience. Illuminate your surroundings with style and grace – embrace the allure of the Cosca.

Overview

Family name	Cosca
Categories	Coach Lights
Mounting	Surface
Usage	Outdoor Lighting

Color / Material

Fixture Color	Black
Fixture Finish	Sand
Fixture Material	Aluminium, Glass
Canopy Color	Black
Glass Color	Smoke

Size

Fixture Width (cm)	14.5
Fixture Height (cm)	26.0
Fixture Projection (cm)	14.0

Specification

Voltage Input	240V
Total Wattage (max)	25
Globe Type	E27
Globe / Light Source qty	1
Globe / Light Source included	No
Electrical Protection	CLASS I - HIGH VOLTAGE, EARTH REQUIRED
IP rating	IP43

All representations within this document are subject to copyright. ELECTRICAL INSTALLATIONS MUST BE PERFORMED BY A QUALIFIED ELECTRICAL CONTRACTOR AND INSTALLED IN ACCORDANCE WITH AS/NZS 3000.
NOTE : All images , descriptions and dimensions are indicative. Please check latest version of item detail on Telbix website prior to ordering or installation.

Lead and Plug	No
Approvals	RCM
Assembly Required	No
Installation Required	Yes (by Licensed Electrician only)
Care Instructions	Do not use strong liquid cleaners, Wipe clean with a dry cloth, Aluminium, Brass and Stainless Steel will naturally oxidised and change overtime. Exterior products require regular four (4) monthly cleaning and maintenance to ensure they do not accumulate dirt or other environmental deposits. Wipe the product with a mild detergent and warm water to remove surface deposits. Rinse with fresh water and wipe dry with a soft cloth. An extra temporary protection barrier of water displacement oil can help to maintain the surface, such as WD40, sprayed onto a soft cloth and rubbed onto the surface.
Replacement Warranty	*3 Years

Barcode

GTIN 9329501066195

Image -dimensions

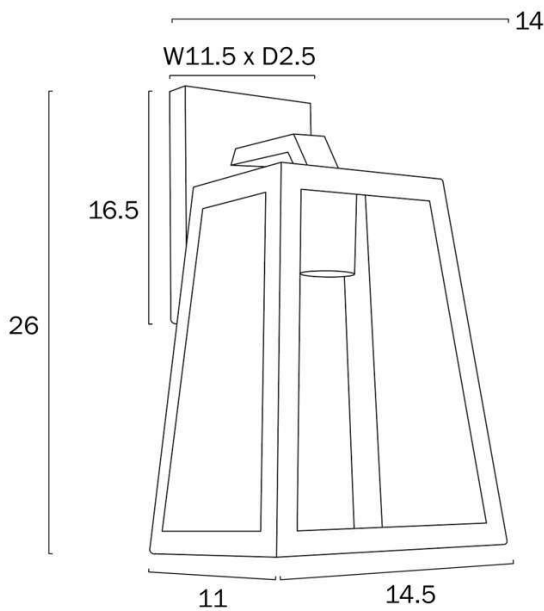

Note: Dimensions are only a guide and may vary due to manufacturing variations.

