



# TD SILENT

## IN-LINE DUCT MOUNTED FAN



The Silent Series of in-line mixed-flow fans incorporates a number of new technologies that make them the quietest fan in its class. This high performance fan is ideal for noise sensitive areas such as apartments, hotels and offices where rooms are often close together.

- High performance mixed-flow impeller.
- Low noise operation.
- Vibration absorbing elements are integrated into the advanced body design.
- 360° rotating junction box makes connection of power cable easier (applicable for 100, 125, 150 and 200mm sizes only).
- Integral mounting foot makes installation simple.
- 1 to 30 minute run-on timer available on 100 to 200mm models.
- Includes plug and lead for easy installation.
- Convenient 2-speed motor, factory set to high speed (single speed on models with run-on timer).
- Fan body can be easily removed without disturbing connected ductwork.

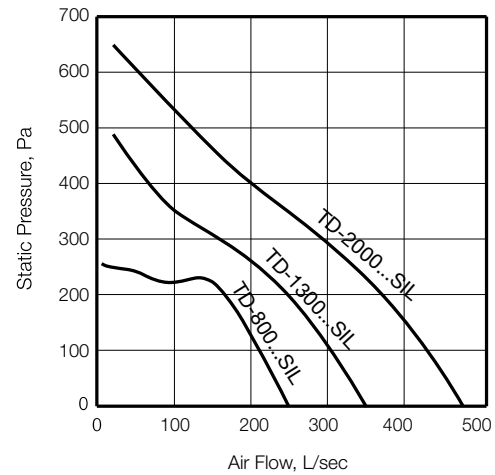
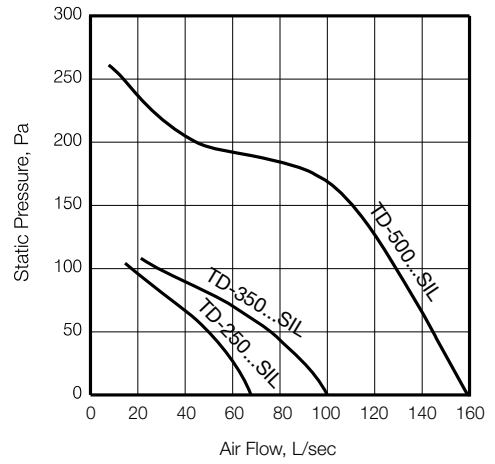

Rubber gaskets on spigots help to reduce air leakage and absorb vibration. Easy to release clamps.

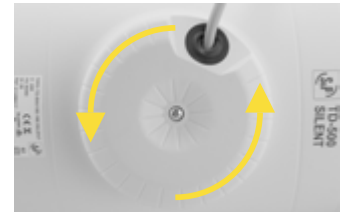

360° rotating junction box.

## ACCESSORIES

- Run-on Timers & Speed Controllers.
- Flexible Duct - Fire Rated AS/NZS 4254.
- Backdraft Dampers.
- Internal and external grilles.

MODEL NO.	M <sup>3</sup> /HR <sup>†</sup>	L/SEC <sup>†</sup>	FAN SPEED RPM	AVG. dB(A) @ 3M	WATTS	VOLTS
TD-250/100SIL	240	66	2200	36	24	240
TD-250/100SILT-4PL*	240	66	2200	36	24	240
TD-350/125SIL	360	100	2250	33	30	240
TD-350/125SILT-4PL*	360	100	2250	33	30	240
TD-500/150SIL	570	158	2500	40	50	240
TD-500/150SILT-4PL*	570	158	2500	40	50	240
TD-800/200SIL	900	249	2780	42	95	240
TD-800/200SILT-4PL*	900	249	2780	42	95	240
TD-1300/250SIL	1270	352	2570	47	197	240
TD-2000/315SIL	1760	488	2680	50	297	240

<sup>†</sup> Air flow without duct and fittings \* Includes a 1-30 minute adjustable run-on timer  
Performance data and curves shown are for high speed.

# COMPACT UNITS

100MM, 125MM, 150MM & 200MM

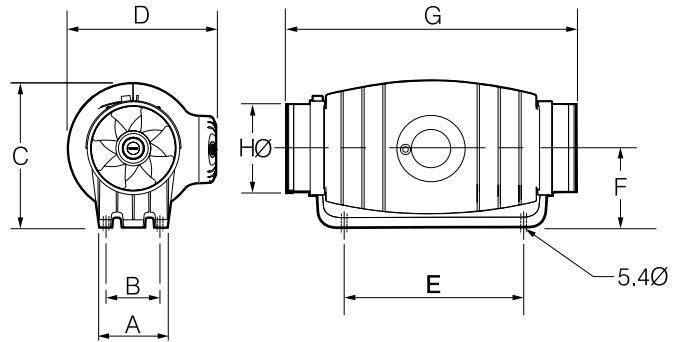
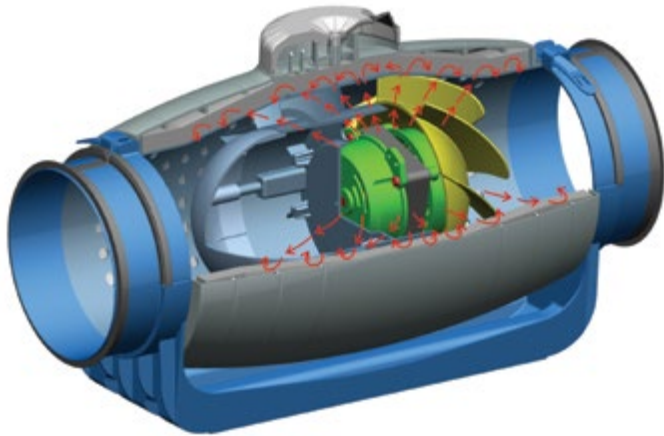

MODEL NO.	A	B	C	D	E	F	G	HØ
TD-250/100SIL	100	83	223	233	250	121	575	97
TD-350/125SIL	100	83	223	233	250	121	462	123
TD-500/150SIL	116	96	245	251	250	134	484	147
TD-800/200SIL	145	129	296	296	340	164	568	198

All dimensions in mm

# HIGH CAPACITY UNITS

250MM & 315MM

- Aerodynamic inlet improves air flow.
- Made from durable sheet steel.

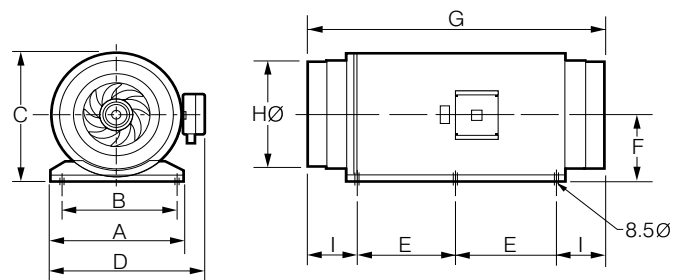
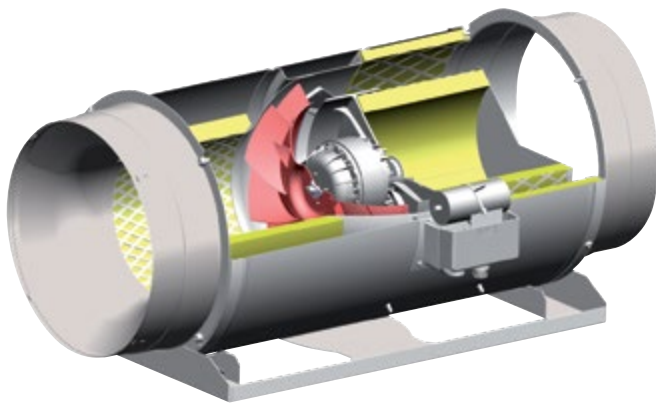

MODEL NO.	A	B	C	D	E	F	G	HØ	I
TD-1300/250SIL	300	280	331	387	200	171	680	248	140
TD-2000/315SIL	370	335	373	432	260	192	825	312	152

All dimensions in mm