



Orbital

450MM COMMERCIAL GRADE
CEILING MOUNT COOLING FAN

- 360 degree orbital motion for maximum cooling effect.
- High airflow, low noise.
- New anti-vibration patented blade design.
- Ideal for warmer climate areas.
- Three speed settings.

Orbital



450MM COMMERCIAL GRADE CEILING MOUNT COOLING FAN

45cm Oscillating Cooling Fan with Matte White Grille and brushed aluminium blades.



FAN	450MM
Blade Count:	Three
Materials:	Aluminium
Sweep Size:	450mm
Motor Type:	Ball Bearing
Motor Wattage:	160 watts
Speed H/M/L:	1400/1200/900 RPM
Control:	Wall Switch

INSTALLATION	
Suitable for:	Indoors
Power Input:	220-240V~50Hz
Installation:	Qualified Electrician Needed
Warranty:	2 Years

SHIPPING	
Packaging Size (mm):	720 x 140 x 535mm
Gross Weight:	7 kg
Pallet Qty:	36 pieces

DIMENSIONS

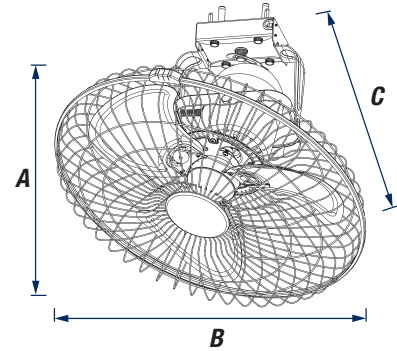

Model	A	B	C (Hang)
ORB45	515mm	515mm	345mm

INCLUDES

- 1 x Cooling Fan
- 1 x Instruction Manual
- 1 x Three Speed Wall Switch



Model	Colour	Outer Carton	EAN13 Barcode
ORB45	White	19339310008917	9 339310 008910 >

ventairtm
THE AIR MOVEMENT SPECIALISTS

- +61 3 9775 0556
- +61 3 9775 0775
- sales@ventair.com.au

4 Capital Place, Carrum Downs Vic 3201
www.ventair.com.au