

Last modification

2022-12-03

## HERTEL PE20-BKAM 9329501043455



The HERTEL floor lamp has a swiveling joint, so you can move, adjust, and fine-tune the position it for the ideal light for whatever you're doing, whether reading or working. The main base is finished in satin Black with contrasts in Antique brass. The mouth blown glass shade is clear amber providing a warm light when in operation.

### Overview

<b>Family name</b>	Hertel
<b>Categories</b>	Pendants
<b>Mounting</b>	Surface
<b>This item includes</b>	Glass,Suspension
<b>Suspension Type</b>	Cable
<b>Usage</b>	Indoor Lighting

### Color / Material

<b>Fixture Color</b>	Black,Amber
<b>Fixture Material</b>	Glass,Metal
<b>Canopy Color</b>	Black
<b>Shade Color</b>	Amber
<b>Shade Material</b>	Glass
<b>Glass Color</b>	Amber
<b>Cable Color</b>	Black
<b>Cable Material</b>	PVC

### Size

<b>Fixture Diameter (cm)</b>	20.0
<b>Fixture Height (cm)</b>	17.0

### Specification

<b>Voltage Input</b>	240V
<b>Wattage (max)</b>	25
<b>Globe Type</b>	E27
<b>Globe / Light Source qty</b>	1
<b>Globe / Light Source included</b>	No

All representations within this document are subject to copyright.ELECTRICAL INSTALLATIONS MUST BE PERFORMED BY A QUALIFIED ELECTRICAL CONTRACTOR AND INSTALLED IN ACCORDANCE WITH AS/NZS 3000.  
NOTE : All images , descriptions and dimensions are indicative. Please check latest version of item detail on Telbix website prior to ordering or installation.

<b>Electrical Protection</b>	CLASS I - HIGH VOLTAGE, EARTH REQUIRED
<b>IP rating</b>	IP20
<b>Lead and Plug</b>	No
<b>Approvals</b>	RCM
<b>Box Contents</b>	Basic mounting screws,Instruction
<b>Installation Required</b>	Yes (by Licensed Electrician only)
<b>Care Instructions</b>	Do not use strong liquid cleaners,Wipe clean with a dry cloth
<b>Replacement Warranty</b>	*3 Years

## Barcode

**GTIN** 9329501043455

## Image -dimensions

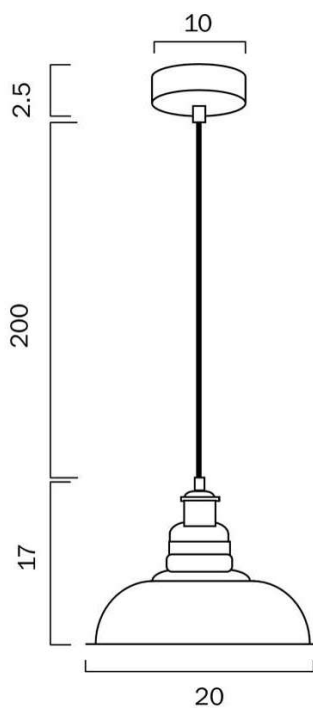

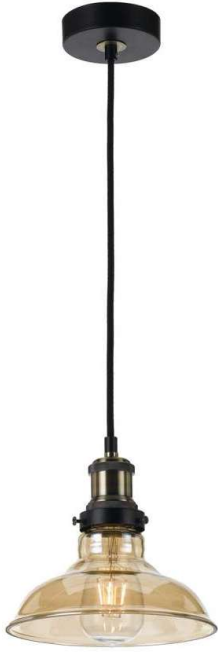



Last modification

2022-12-03

## HERTEL PE30-BKAM

9329501043462



The HERTEL pendant is suspended by a textile cable. The cable is Black with contrasts in Antique brass for the globe gallery. The mouth blown glass shade is clear amber providing a warm light when in operation. Available in 20cm and 30cm.

### Overview

<b>Family name</b>	Hertel
<b>Categories</b>	Pendants
<b>Mounting</b>	Surface
<b>This item includes</b>	Glass,Suspension
<b>Suspension Type</b>	Cable
<b>Usage</b>	Indoor Lighting

### Color / Material

<b>Fixture Color</b>	Black,Amber
<b>Fixture Material</b>	Glass,Metal
<b>Canopy Color</b>	Black
<b>Shade Color</b>	Amber
<b>Shade Material</b>	Glass
<b>Glass Color</b>	Amber
<b>Cable Color</b>	Black
<b>Cable Material</b>	PVC

### Size

<b>Fixture Diameter (cm)</b>	30.0
<b>Fixture Height (cm)</b>	22.5

### Specification

<b>Voltage Input</b>	240V
<b>Wattage (max)</b>	25
<b>Globe Type</b>	E27
<b>Globe / Light Source qty</b>	1
<b>Globe / Light Source included</b>	No
<b>Electrical Protection</b>	CLASS I - HIGH VOLTAGE, EARTH REQUIRED

All representations within this document are subject to copyright.ELECTRICAL INSTALLATIONS MUST BE PERFORMED BY A QUALIFIED ELECTRICAL CONTRACTOR AND INSTALLED IN ACCORDANCE WITH AS/NZS 3000.  
NOTE : All images , descriptions and dimensions are indicative. Please check latest version of item detail on Telbix website prior to ordering or installation.

<b>IP rating</b>	IP20
<b>Lead and Plug</b>	No
<b>Approvals</b>	RCM
<b>Box Contents</b>	Basic mounting screws,Instruction
<b>Installation Required</b>	Yes (by Licensed Electrician only)
<b>Care Instructions</b>	Do not use strong liquid cleaners,Wipe clean with a dry cloth
<b>Replacement Warranty</b>	*3 Years

Barcode

**GTIN** 9329501043462

Image -dimensions

