

Last modification 2022-11-21

DELMAR WB-NKOM 9329501061947



The DELMAR wall lamp is a fusion of simple shade design and traditional robust metals. Blending yesteryears inspiration this exquisite wall lamp will add a premium atmosphere to your exclusive living space.

Overview

Family name	Delmar
Categories	Wall Lights
Mounting	Surface
This item includes	Glass
Usage	Indoor Lighting

Color / Material

Fixture Color	Nickel,Opal Matt
Fixture Material	Metal,Glass
Canopy Color	Nickel
Shade Material	Glass
Glass Color	Opal Matt

Size

Fixture Width (cm)	12.5
Fixture Height (cm)	27.0
Fixture Projection (cm)	17.0
Canopy Diameter (cm)	10.0
Canopy Projection (cm)	3.0
Shade Diameter (cm)	10.0
Shade Height (cm)	20.0

Specification

Voltage Input	240V
Wattage (max)	25
Globe Type	E27
Globe / Light Source qty	1
Globe / Light Source included	No

All representations within this document are subject to copyright.ELECTRICAL INSTALLATIONS MUST BE PERFORMED BY A QUALIFIED ELECTRICAL CONTRACTOR AND INSTALLED IN ACCORDANCE WITH AS/NZS 3000.
NOTE : All images , descriptions and dimensions are indicative. Please check latest version of item detail on Telbix website prior to ordering or installation.

Dimmable	Globe Dependant
Electrical Protection	CLASS I - HIGH VOLTAGE, EARTH REQUIRED
IP rating	IP20
Approvals	RCM
Box Contents	Basic mounting screws,Instruction
Installation Required	Yes (by Licensed Electrician only)
Care Instructions	Do not use strong liquid cleaners,Wipe clean with a dry cloth
Replacement Warranty	*3 Years

Barcode

GTIN 9329501061947

Image -dimensions

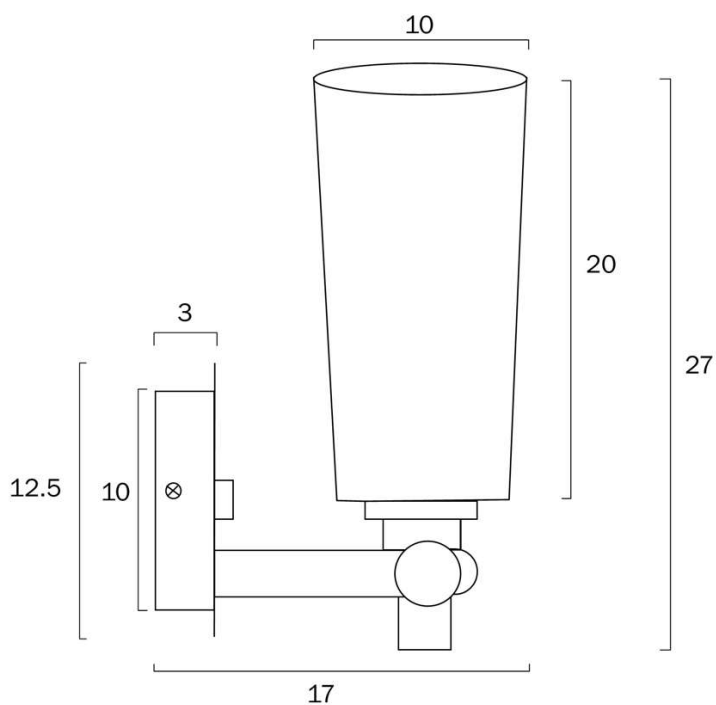





Last modification 2022-11-21

DELMAR WB-BKOM 9329501062562



The DELMAR wall lamp is a fusion of simple shade design and traditional robust metals. Blending yesteryears inspiration this exquisite wall lamp will add a premium atmosphere to your exclusive living space.

Overview

Family name	Delmar
Categories	Wall Lights
Mounting	Surface
This item includes	Glass
Usage	Indoor Lighting

Color / Material

Fixture Color	Black,Antique Gold,Opal Matt
Fixture Material	Metal,Glass
Canopy Color	Black,Antique Gold
Shade Material	Glass
Glass Color	Opal Matt

Size

Fixture Width (cm)	12.5
Fixture Height (cm)	27.0
Fixture Projection (cm)	17.0
Canopy Diameter (cm)	10.0
Canopy Projection (cm)	3.0
Shade Diameter (cm)	10.0
Shade Height (cm)	20.0

Specification

Voltage Input	240V
Wattage (max)	25
Globe Type	E27
Globe / Light Source qty	1
Globe / Light Source included	No

All representations within this document are subject to copyright.ELECTRICAL INSTALLATIONS MUST BE PERFORMED BY A QUALIFIED ELECTRICAL CONTRACTOR AND INSTALLED IN ACCORDANCE WITH AS/NZS 3000.
NOTE : All images , descriptions and dimensions are indicative. Please check latest version of item detail on Telbix website prior to ordering or installation.

Dimmable	Globe Dependant
Electrical Protection	CLASS I - HIGH VOLTAGE, EARTH REQUIRED
IP rating	IP20
Approvals	RCM
Box Contents	Basic mounting screws,Instruction
Installation Required	Yes (by Licensed Electrician only)
Care Instructions	Do not use strong liquid cleaners,Wipe clean with a dry cloth
Replacement Warranty	*3 Years

Barcode

GTIN 9329501062562

Image -dimensions

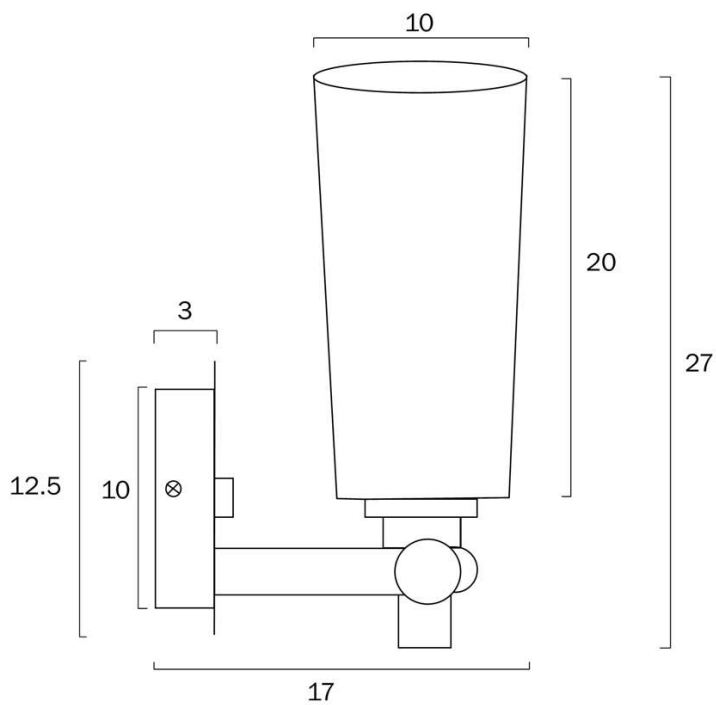





Last modification 2022-11-21

DELMAR WB-BKCL 9329501061930



The DELMAR wall lamp is a fusion of simple shade design and traditional robust metals. Blending yesteryears inspiration this exquisite wall lamp will add a premium atmosphere to your exclusive living space.

Overview

Family name	Delmar
Categories	Wall Lights
Mounting	Surface
This item includes	Glass
Usage	Indoor Lighting

Color / Material

Fixture Color	Black,Antique Gold,Clear
Fixture Material	Metal,Glass
Canopy Color	Black,Antique Gold
Shade Material	Glass
Glass Color	Clear

Size

Fixture Width (cm)	12.5
Fixture Height (cm)	27.0
Fixture Projection (cm)	17.0
Canopy Diameter (cm)	10.0
Canopy Projection (cm)	3.0
Shade Diameter (cm)	10.0
Shade Height (cm)	20.0

Specification

Voltage Input	240V
Wattage (max)	25
Globe Type	E27
Globe / Light Source qty	1
Globe / Light Source included	No

All representations within this document are subject to copyright.ELECTRICAL INSTALLATIONS MUST BE PERFORMED BY A QUALIFIED ELECTRICAL CONTRACTOR AND INSTALLED IN ACCORDANCE WITH AS/NZS 3000.
NOTE : All images , descriptions and dimensions are indicative. Please check latest version of item detail on Telbix website prior to ordering or installation.

Dimmable	Globe Dependant
Electrical Protection	CLASS I - HIGH VOLTAGE, EARTH REQUIRED
IP rating	IP20
Approvals	RCM
Box Contents	Basic mounting screws,Instruction
Installation Required	Yes (by Licensed Electrician only)
Care Instructions	Do not use strong liquid cleaners,Wipe clean with a dry cloth
Replacement Warranty	*3 Years

Barcode

GTIN 9329501061930

Image -dimensions

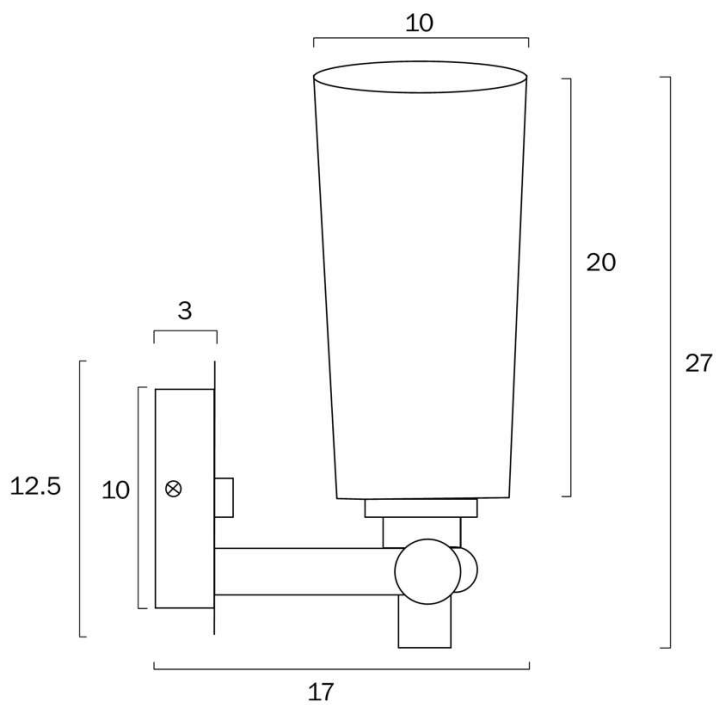





Last modification 2022-11-21

DELMAR WB-AGOM 9329501061923



The DELMAR wall lamp is a fusion of simple shade design and traditional robust metals. Blending yesteryears inspiration this exquisite wall lamp will add a premium atmosphere to your exclusive living space.

Overview

Family name	Delmar
Categories	Wall Lights
Mounting	Surface
This item includes	Glass
Usage	Indoor Lighting

Color / Material

Fixture Color	Opal Matt,Antique Gold
Fixture Material	Metal,Glass
Canopy Color	Antique Gold
Shade Material	Glass
Glass Color	Opal Matt

Size

Fixture Width (cm)	12.5
Fixture Height (cm)	27.0
Fixture Projection (cm)	17.0
Canopy Diameter (cm)	10.0
Canopy Projection (cm)	3.0
Shade Diameter (cm)	10.0
Shade Height (cm)	20.0

Specification

Voltage Input	240V
Wattage (max)	25
Globe Type	E27
Globe / Light Source qty	1
Globe / Light Source included	No

All representations within this document are subject to copyright.ELECTRICAL INSTALLATIONS MUST BE PERFORMED BY A QUALIFIED ELECTRICAL CONTRACTOR AND INSTALLED IN ACCORDANCE WITH AS/NZS 3000.
NOTE : All images , descriptions and dimensions are indicative. Please check latest version of item detail on Telbix website prior to ordering or installation.

Dimmable	Globe Dependant
Electrical Protection	CLASS I - HIGH VOLTAGE, EARTH REQUIRED
IP rating	IP20
Approvals	RCM
Box Contents	Basic mounting screws, Instruction
Installation Required	Yes (by Licensed Electrician only)
Care Instructions	Do not use strong liquid cleaners, Wipe clean with a dry cloth
Replacement Warranty	*3 Years

Barcode

GTIN 9329501061923

Image -dimensions

