

Last modification

2022-11-12

## AVERA EX15-BRS

9329501051559



More than a light, the AVERA Exterior Wall bracket provides traditional charm for porches, patios and covered gazebos. Its handsome solid brass finish are organic in nature and will darken over time, adding to the classic, worn-in appeal for classic homes.

### Overview

<b>Family name</b>	Avera
<b>Categories</b>	Coach Lights
<b>Mounting</b>	Surface
<b>This item includes</b>	Glass
<b>Usage</b>	Indoor Lighting,Trade Selection

### Color / Material

<b>Fixture Color</b>	Brass
<b>Fixture Material</b>	Brass
<b>Diffuser Material</b>	Glass
<b>Glass Color</b>	Clear

### Size

<b>Fixture Width (cm)</b>	15.0
<b>Fixture Height (cm)</b>	25.5
<b>Base Length (cm)</b>	10.5
<b>Base Width (cm)</b>	2.0
<b>Base Height (cm)</b>	14.0

### Specification

<b>Voltage Input</b>	240V
<b>Wattage (max)</b>	25
<b>Globe Type</b>	E27
<b>Globe / Light Source qty</b>	1
<b>Globe / Light Source included</b>	No
<b>Dimmable</b>	Globe Dependant
<b>Beam Angle (degree)</b>	360

All representations within this document are subject to copyright. ELECTRICAL INSTALLATIONS MUST BE PERFORMED BY A QUALIFIED ELECTRICAL CONTRACTOR AND INSTALLED IN ACCORDANCE WITH AS/NZS 3000.  
NOTE : All images , descriptions and dimensions are indicative. Please check latest version of item detail on Telbix website prior to ordering or installation.

<b>Electrical Protection</b>	CLASS I - HIGH VOLTAGE, EARTH REQUIRED
<b>IP rating</b>	IP43
<b>Lead and Plug</b>	No
<b>Approvals</b>	RCM
<b>Assembly Required</b>	No
<b>Box Contents</b>	Basic mounting screws, Instruction
<b>Installation Required</b>	Yes (by Licensed Electrician only)
<b>Care Instructions</b>	Aluminium, Brass and Stainless Steel will naturally oxidised and change overtime. Exterior products require regular four (4) monthly cleaning and maintenance to ensure they do not accumulate dirt or other environmental deposits. Wipe the product with a mild detergent and warm water to remove surface deposits. Rinse with fresh water and wipe dry with a soft cloth. An extra temporary protection barrier of water displacement oil can help to maintain the surface, such as WD40, sprayed onto a soft cloth and rubbed onto the surface.
<b>Replacement Warranty</b>	*3 Years

Barcode

**GTIN** 9329501051559

Image -dimensions

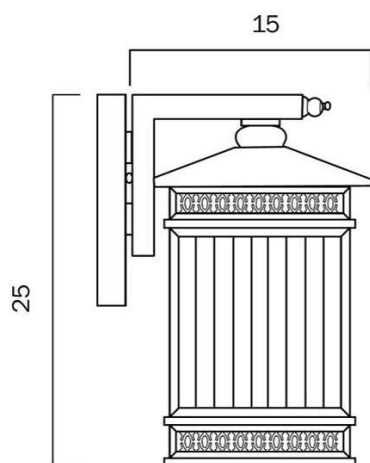





Last modification 2022-11-13

**AVERA EX175-BRS**  
**9329501051566**



More than a light, the AVERA Exterior Wall bracket provides traditional charm for porches, patios and covered gazebos. Its handsome solid brass finish are organic in nature and will darken over time, adding to the classic, worn-in appeal for classic homes.

## Overview

<b>Family name</b>	Avera
<b>Categories</b>	Coach Lights
<b>Mounting</b>	Surface
<b>This item includes</b>	Glass
<b>Usage</b>	Indoor Lighting,Trade Selection

## Color / Material

<b>Fixture Color</b>	Brass
<b>Fixture Material</b>	Brass
<b>Diffuser Material</b>	Glass
<b>Glass Color</b>	Clear

## Size

<b>Fixture Width (cm)</b>	17.5
<b>Fixture Height (cm)</b>	30.0
<b>Base Length (cm)</b>	10.5
<b>Base Width (cm)</b>	2.0
<b>Base Height (cm)</b>	17.0

## Specification

<b>Voltage Input</b>	240V
<b>Wattage (max)</b>	25
<b>Globe Type</b>	E27
<b>Globe / Light Source qty</b>	1
<b>Globe / Light Source included</b>	No
<b>Dimmable</b>	Globe Dependant
<b>Beam Angle (degree)</b>	360

All representations within this document are subject to copyright. ELECTRICAL INSTALLATIONS MUST BE PERFORMED BY A QUALIFIED ELECTRICAL CONTRACTOR AND INSTALLED IN ACCORDANCE WITH AS/NZS 3000.  
NOTE : All images , descriptions and dimensions are indicative. Please check latest version of item detail on Telbix website prior to ordering or installation.

<b>Electrical Protection</b>	CLASS I - HIGH VOLTAGE, EARTH REQUIRED
<b>IP rating</b>	IP43
<b>Lead and Plug</b>	No
<b>Approvals</b>	RCM
<b>Assembly Required</b>	No
<b>Box Contents</b>	Basic mounting screws, Instruction
<b>Installation Required</b>	Yes (by Licensed Electrician only)
<b>Care Instructions</b>	Aluminium, Brass and Stainless Steel will naturally oxidised and change overtime. Exterior products require regular four (4) monthly cleaning and maintenance to ensure they do not accumulate dirt or other environmental deposits. Wipe the product with a mild detergent and warm water to remove surface deposits. Rinse with fresh water and wipe dry with a soft cloth. An extra temporary protection barrier of water displacement oil can help to maintain the surface, such as WD40, sprayed onto a soft cloth and rubbed onto the surface.
<b>Replacement Warranty</b>	*3 Years

Barcode

**GTIN** 9329501051566

Image -dimensions

