

Last modification 2022-11-06

MDL-611-WH
9329501044735



Architectural low-glare down light frame.
Aluminum construction in black finish.
Ideal for domestic or commercial applications.
Module MDL 611 Black
Twist-On System
90mm Cut-Out
Fixed Frame

Overview

Family name	Module
Categories	Downlights
Mounting	Recess
Usage	Indoor Lighting,Trade Selection

Color / Material

Fixture Color	Clear,White
Fixture Material	Aluminium
Diffuser Color	Clear

Size

Fixture Diameter (cm)	10.3
Fixture Height (cm)	4.0
Cut Out	9

Specification

Globe / Light Source qty	1
Globe / Light Source included	No
Insulation class	IC-4
IP rating	IP44
Approvals	RCM
Assembly Required	Yes
Box Contents	Instruction

All representations within this document are subject to copyright.ELECTRICAL INSTALLATIONS MUST BE PERFORMED BY A QUALIFIED ELECTRICAL CONTRACTOR AND INSTALLED IN ACCORDANCE WITH AS/NZS 3000.
NOTE : All images , descriptions and dimensions are indicative. Please check latest version of item detail on Telbix website prior to ordering or installation.

Installation Required	Yes (by Licensed Electrician only)
Care Instructions	Do not use strong liquid cleaners,Wipe clean with a dry cloth
Replacement Warranty	*5 Years

Barcode

GTIN 9329501044735

Image -dimensions

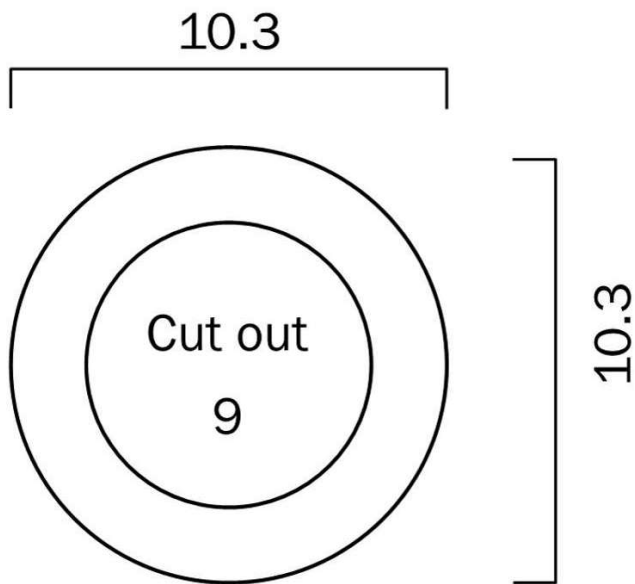

Last modification 2022-11-06

MDL-611-BK
9329501045374



Architectural low-glare down light frame.
Aluminum construction in black finish.
Ideal for domestic or commercial applications.
Module MDL 611 Black
Twist-On System
90mm Cut-Out
Fixed Frame

Overview

Family name	Module
Categories	Downlights
Mounting	Recess
Usage	Indoor Lighting,Trade Selection

Color / Material

Fixture Color	Black
Fixture Material	Aluminium

Size

Fixture Diameter (cm)	10.3
Fixture Height (cm)	4.0

Specification

Globe / Light Source qty	1
Globe / Light Source included	No
Insulation class	IC-4
IP rating	IP44
Approvals	RCM
Assembly Required	Yes
Box Contents	Instruction
Installation Required	Yes (by Licensed Electrician only)
Care Instructions	Do not use strong liquid cleaners,Wipe clean with a dry cloth

All representations within this document are subject to copyright.ELECTRICAL INSTALLATIONS MUST BE PERFORMED BY A QUALIFIED ELECTRICAL CONTRACTOR AND INSTALLED IN ACCORDANCE WITH AS/NZS 3000.
NOTE : All images , descriptions and dimensions are indicative. Please check latest version of item detail on Telbix website prior to ordering or installation.

Replacement Warranty *5 Years

Barcode

GTIN 9329501045374

Image -dimensions

