

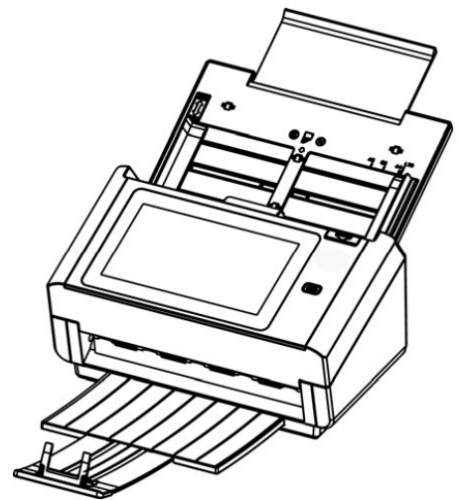

---

# Raven Scanner *Pro* User Manual

---



## **Copyrights and Trademarks**

Ethernet is a registered trademark of Xerox Corporation.

Microsoft, Windows, Windows XP, Windows Vista, Windows 7, Windows 8, and Windows 10 are registered trademarks of Microsoft Corporation in the United States and/or other countries.

Other product names used herein are for identification purposes only and may be trademarks of their respective companies. We disclaim any and all rights to those marks.

## **Warranty**

### **Hardware Warranty**

Machine: The Raven Scanner (“Machine” or “Hardware”); Duration: 1 Year (“Warranty Period”); Warranty for Machines: Starfish Technologies, LLC dba Raven (“Manufacturer” or “Raven”) warrants that each Machine is free from defects in materials and workmanship and conforms to the manufacturer’s published specifications. The warranty period for each Machine is a specified, fixed period commencing on its date of purchase, as evidenced by your original or digital sales receipt; Extent of Warranty: In addition to the limitations and exclusions set forth in the “Disclaimer of Warranties” below, the warranty does not cover the repair or exchange of a Machine resulting from misuse, accident, modification, unsuitable physical or operating environment, improper maintenance or failure caused by a product for which the Manufacturer is not responsible or for cosmetic defects as long as such defects do not interfere with the functionality or performance of the Machine. The warranty is voided by removal or alteration of Machine parts or identification labels; Items not covered by the warranty: Owner computer operating system, application programs other than Raven software or hardware configurations; Return Policy: Machines can be returned within 30 days with proof of purchase (original or digital receipt) in its original packaging. After 30 days from the original date of purchase, a Machine cannot be returned. A Machine cannot be returned if it is damaged as a result of misuse, accident, modification, unsuitable physical or operating environment, improper maintenance or failure caused by a product for which the manufacturer is not responsible. The return policy is voided by removal or alteration of machine parts or identification labels.

### **Disclaimer of Warranties**

YOU EXPRESSLY ACKNOWLEDGE AND AGREE THAT USE OF THE RAVEN SOFTWARE AND HARDWARE IS AT YOUR SOLE RISK AND THAT THE ENTIRE RISK AS TO SATISFACTORY QUALITY, PERFORMANCE, ACCURACY AND EFFORT IS WITH YOU. EXCEPT FOR THE LIMITED WARRANTY ON MEDIA AND HARDWARE SET FORTH

ABOVE AND TO THE MAXIMUM EXTENT PERMITTED BY APPLICABLE LAW, THE RAVEN SOFTWARE AND HARDWARE ARE PROVIDED "AS IS", WITH ALL FAULTS AND WITHOUT WARRANTY OF ANY KIND, AND RAVEN AND RAVEN'S LICENSORS HEREBY DISCLAIM ALL WARRANTIES AND CONDITIONS WITH RESPECT TO THE SOFTWARE AND HARDWARE, EITHER EXPRESS, IMPLIED OR STATUTORY, INCLUDING, BUT NOT LIMITED TO, THE IMPLIED WARRANTIES AND/OR CONDITIONS OF MERCHANTABILITY, OF SATISFACTORY QUALITY, OF FITNESS FOR A PARTICULAR PURPOSE, OF ACCURACY, OF QUIET ENJOYMENT, AND NON-INFRINGEMENT OF THIRD PARTY RIGHTS. RAVEN DOES NOT WARRANT AGAINST INTERFERENCE WITH YOUR ENJOYMENT OF THE RAVEN SOFTWARE AND HARDWARE, THAT THE FUNCTIONS CONTAINED IN THE RAVEN SOFTWARE AND HARDWARE WILL MEET YOUR REQUIREMENTS, THAT THE OPERATION OF THE RAVEN SOFTWARE AND HARDWARE WILL BE UNINTERRUPTED OR ERROR-FREE, OR THAT DEFECTS IN THE RAVEN SOFTWARE AND HARDWARE WILL BE CORRECTED. NO ORAL OR WRITTEN INFORMATION OR ADVICE GIVEN BY RAVEN OR A RAVEN AUTHORIZED REPRESENTATIVE SHALL CREATE A WARRANTY. AFTER THE END OF THE WARRANTY PERIOD, SHOULD THE RAVEN SOFTWARE AND HARDWARE PROVE DEFECTIVE, YOU ASSUME THE ENTIRE COST OF ALL NECESSARY SERVICING, REPAIR OR CORRECTION. SOME JURISDICTIONS DO NOT ALLOW THE EXCLUSION OF IMPLIED WARRANTIES OR LIMITATIONS ON APPLICABLE STATUTORY RIGHTS OF A CONSUMER, SO THE ABOVE EXCLUSION AND LIMITATIONS MAY NOT APPLY TO YOU.

RAVEN'S LIMITED WARRANTY DOES NOT APPLY TO A RAVEN PRODUCT THAT HAS BEEN SUBJECTED TO PHYSICAL DAMAGE AFTER PURCHASE, CAUSED, FOR EXAMPLE, BY CASUALTY, ACCIDENT, ACTS OF GOD OR TRANSPORTATION, INCLUDING (A) BY A FAILURE TO PROPERLY PACKAGE AND SHIP THE IMAGING PRODUCT BACK TO RAVEN FOR WARRANTY SERVICE IN ACCORDANCE WITH RAVEN'S THEN CURRENT PACKAGING AND SHIPPING GUIDELINES, INCLUDING FAILURE TO REPLACE THE SHIPPING RESTRAINT PRIOR TO SHIPPING, OR BY A FAILURE TO REMOVE THE SHIPPING RESTRAINT PRIOR TO USE; (B) RESULTING FROM THE USER'S INSTALLATION, SYSTEM INTEGRATION, PROGRAMMING, RE-INSTALLATION OF USER OPERATING SYSTEMS OR APPLICATIONS SOFTWARE, SYSTEMS ENGINEERING, RELOCATION, RECONSTRUCTION OF DATA, OR REMOVAL OF THE PRODUCT OR ANY COMPONENT (INCLUDING BREAKAGE OF A CONNECTOR, COVER, GLASS, PINS, OR SEAL); (C) FROM SERVICE, MODIFICATION OR REPAIR NOT PERFORMED BY RAVEN OR A SERVICE PROVIDER AUTHORIZED BY RAVEN OR BY TAMPERING, USE OF COUNTERFEIT OR OTHER NON-RAVEN COMPONENTS, ASSEMBLIES, ACCESSORIES, OR MODULES; (D) BY MISUSE, UNREASONABLE HANDLING OR MAINTENANCE, MISTREATMENT, OPERATOR ERROR, FAILURE TO PROVIDE PROPER SUPERVISION OR MAINTENANCE INCLUDING USE OF CLEANING PRODUCTS OR OTHER ACCESSORIES NOT APPROVED BY RAVEN OR USE IN CONTRAVENTION OF RECOMMENDED PROCEDURES OR SPECIFICATIONS; (E) BY ENVIRONMENTAL CONDITIONS (SUCH AS EXCESSIVE HEAT OR OTHER UNSUITABLE PHYSICAL OPERATING ENVIRONMENT), CORROSION, STAINING, ELECTRICAL WORK EXTERNAL TO THE PRODUCT OR FAILURE TO PROVIDE ELECTRO-STATIC DISCHARGE (ESD) PROTECTION; (F) BY FAILURE TO

INSTALL FIRMWARE UPDATES OR RELEASES AVAILABLE FOR THE PRODUCT AND (G) BY SUCH OTHER SUPPLEMENTAL EXCLUSIONS PUBLISHED FROM TIME TO TIME ONLINE AT [HTTPS://WWW.RAVEN.COM/WARRANTY](https://www.raven.com/warranty).

PURCHASERS OF PRODUCTS FROM FOREIGN DISTRIBUTION CHANNELS MUST SEEK WARRANTY COVERAGE, IF ANY, THROUGH THE ORIGINAL SOURCE OF PURCHASE. RAVEN PROVIDES NO LIMITED WARRANTY FOR PRODUCTS THAT ARE PURCHASED AS PART OF A THIRD PARTY MANUFACTURER'S PRODUCT, COMPUTER SYSTEM OR OTHER ELECTRONIC DEVICE. ANY WARRANTY FOR THESE PRODUCTS IS PROVIDED BY THE OEM (ORIGINAL EQUIPMENT MANUFACTURER) AS PART OF THAT MANUFACTURER'S PRODUCT OR SYSTEM. THE REPLACEMENT PRODUCT ASSUMES THE REMAINDER OF THE LIMITED WARRANTY PERIOD APPLICABLE TO THE DEFECTIVE PRODUCT OR THIRTY (30) DAYS, WHICHEVER IS LONGER.

If any provision of this Limited Warranty is legally invalid, the warranty shall endure except for the invalid provision. This Limited Warranty constitutes the entire agreement between the parties with respect to the use of the Machine.

IN NO EVENT WILL MANUFACTURER BE LIABLE FOR ANY LOST REVENUE, PROFIT, DATA OR FOR SPECIAL, CONSEQUENTIAL, INDIRECT, INCIDENTAL OR PUNITIVE DAMAGES HOWEVER CAUSED AND REGARDLESS OF THE THEORY OF LIABILITY ARISING OUT OF THE USE OR INABILITY TO USE THE MACHINES EVEN IF MANUFACTURER HAS BEEN ADVISED OF THE POSSIBILITY OF SUCH DAMAGES. IN NO EVENT WILL MANUFACTURER'S LIABILITY, WHETHER IN CONTRACT, TORT OR OTHERWISE, EXCEED THE PRICE PAID BY CUSTOMER.

The laws of your country or state may require a warranty term longer than one (1) year, in which case the Manufacturer will provide the minimum warranty term required by applicable law.

## **HOW TO OBTAIN LIMITED WARRANTY SERVICE**

Raven Scanners are supplied with information on unpacking, setup, installation and operation. Careful reading of the materials will answer most of the questions the end user might have regarding proper installation, operation and maintenance of the product. However, should additional technical support be required, you may visit our website at: <https://www.raven.com/faq> or contact: 1-800-713-9009

In order to properly service you, please be prepared to describe your issue and provide the Raven account email address, scanner model, serial number and proof of purchase.

For more Raven Scanner information, visit our website at: <https://www.raven.com/>

## Safety Information

When using this machine, the following safety precautions should always be followed.

### Safety During Operation

In this manual, the following important symbols are used:

- **WARNING:**

Indicates potentially hazardous situations, which if instructions are not followed, could result in death or serious injury.

- **CAUTION:**

Indicates a potentially hazardous situation which, if instructions are not followed, may result in minor or moderate injury or damage to property.

**Important:**

Indicates operational requirements and restrictions. Please read and follow these instructions to ensure a proper operation and to avoid damage to the hardware.

**Note:**

Indicates further explanation or clarification. Reading this is highly recommended.

- **WARNING:**

To avoid hazardous electric shock or fire, do not remove any covers or screws other than those specified in this manual.

- **CAUTION:**

- ✓ To reduce the risk of fire, use only no.26AWG or larger telecommunication line cord.
- ✓ Disconnect the power plug by pulling the plug, not the cable.
- ✓ Do not touch the metal fingers of the ADF pad module. The edges are sharp and touching them may result in injury.

### Precautions

- Do not install the hardware near heating or air conditioning units.
- Do not install the hardware in a humid or dusty place.
- Place the hardware securely on an even, flat surface. Tilted or uneven surfaces may cause mechanical or paper-feeding problems.
- Retain the box and packing materials for shipping purposes.

## **Federal Communications Commission (FCC) compliance information statement**

### **Part 15**

This hardware has been tested and found to comply with the limits for a Class B digital device, pursuant to Part 15 of the FCC Rules. These limits are designed to provide reasonable protection against harmful interference in a residential installation. This hardware generates, uses and can radiate radio frequency energy and, if not installed and used in accordance with the instructions, may cause harmful interference to radio communications. However, there is no guarantee that interference will not occur in a particular installation. If this hardware does cause harmful interference to radio or television reception, which can be determined by turning the hardware off and on. The user is encouraged to try to correct the interference by one of the following measures:

- Reorient or relocate the receiving antenna.
- Increase the separation between the hardware and receiver.
- Connect the hardware into an outlet on a circuit different from that to which the receiver is connected.
- Consult the dealer or an experienced radio/TV technician for help.

This device complies with Part 15 of the FCC Rules. Operation is subject to the following two conditions: (1) This device may not cause harmful interference, and (2) this device must accept any interference received, including interference that may cause undesired operation.

#### **FCC Caution:**

Any changes or modifications not expressly approved by the party responsible for compliance could void the user's authority to operate this hardware.

This device is intended only for OEM integrators under the following conditions:

- 1) The antenna must be installed such that 20 cm is maintained between the antenna and users.
- 2) The transmitter module may not be co-located with any other transmitter or antenna.

#### **FCC Radiation Exposure Statement:**

This hardware complies with FCC radiation exposure limits set forth for an uncontrolled environment. This hardware should be installed and operated with minimum distance 20cm between the radiator & your body. To maintain compliance with FCC RF exposure compliance requirements, please avoid direct contact to the transmitting antenna during transmitting.

**"Contains FCC ID: YAI2213"**

## Product Safety Guide

Please clearly read all these instructions and follow all instructions and warnings before installing and using the device.

The following indications are used in this document to obviate any chance of accident or damage to you and/or the device.

● <b>WARNING</b>	Indicates potentially hazardous situations, which if instructions are not followed, could result in death or serious injury.
● <b>CAUTION</b>	Indicates a potentially hazardous situation which, if instructions are not followed, may result in minor or moderate injury or damage to property.

- **WARNING**

- Use only the AC power adapter that came with your device. Using any other AC power adapter could cause fire, electrical shock, or injury.
- Use only the AC power cord and USB cable that came with your device and avoid abrasions, cuts, fraying, crimping, and kinking. Using any other AC power cord and USB cable could cause fire, electrical shock, or injury.
- Do not place objects on top of the AC power cord, and do not allow the AC power adapter or the AC power cord to be stepped on or run over.
- Place the device and its AC power adapter near an electrical outlet where the AC power adapter can easily be unplugged.
- If you use an extension cord with the device, make sure that the total ampere rating of the devices plugged into the extension cord does not exceed the cord's ampere rating.
- Place the device close enough to the computer so that the interface cable can easily reach between the device and the computer.
- Do not place or store the device or its AC power adapter:
  - Outdoors
  - Near excessive dirt or dust, water, or heat sources
  - In locations subject to shocks, vibrations, high temperature or humidity, direct sunlight, strong light sources, or rapid changes in temperature or humidity
- Do not use the device with wet hands.
- Never disassemble, modify, or attempt to repair the AC power adapter, device, or device option by yourself, except as specifically explained in the device's documentation. This could cause fire, electrical shock, or injury.
- Do not insert objects into any opening, as they may touch dangerous voltage points or short-out components. Beware of electrical shock hazards.

- Unplug the device and the AC power adapter, and refer servicing to qualified service personnel under the following conditions:
  - The AC power adapter or plug is damaged.
  - Liquid has entered the device or the AC power adapter.
  - Object has entered the device or the AC power adapter.
  - The device or the AC power adapter has been dropped, or the case has been damaged.
  - The device or the AC power adapter does not operate normally (i.e. appearance of smoke, strange smell, odd noise, etc.), or exhibits a distinct change in performance
- Unplug the device and the AC power adapter before cleaning.
  
- **CAUTION**
  - Do not locate the device on rickety or aslope tables. Do not locate the device on unstable surface. The device may fall down and this may result in injury.
  - Do not place heavy objects on the unit. It may cause unbalance and the device may fall down. This may result in injury.
  - Store the AC Power cord/USB cable bundled out of the reach of children to avoid the risk of injury.
  - Keep plastic bags bundled out of the reach of children to avoid the danger of suffocation.
  - If you are not going to use the device for a long period, unplug the AC power adapter from the electrical outlet.

### **Disposal of Waste Equipment by Users in Private Union**



This symbol on the product or on its packaging indicates that the product cannot be disposed of with your other household waste. Instead it should be sent to appropriate facilities for recovery and recycling in an effort to protect human health and the environment. For more information about where you can drop off your waste equipment for recycling, please contact your local city office, your household waste disposal service or the shop where you purchased the product.



# Getting Started

## Introduction

Thank you for purchasing the Raven Scanner Pro. With the internet-connected Raven Scanner, you can instantly scan single-sided or double-sided document(s) and deliver the electronic images to various destinations including e-mail addresses, fax, and cloud services such as Raven Cloud, Dropbox, Google Drive or Evernote. In addition, the product also allows you to save the scanned image to an inserted USB flash drive.

## Package Items

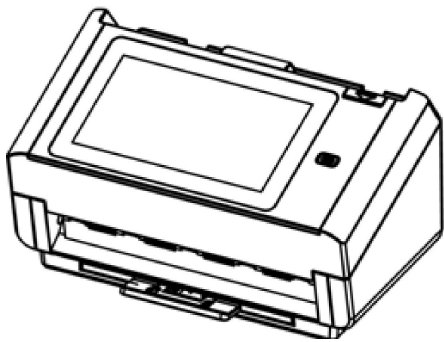

**Raven Scanner Pro**

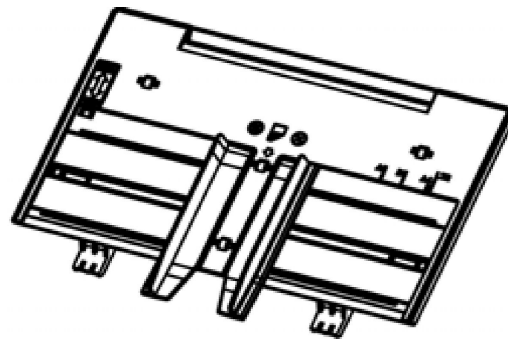

**Automatic Document Feeder Paper Tray**

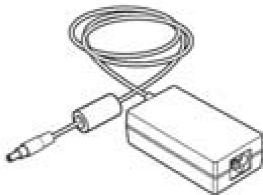

**Power Adapter**

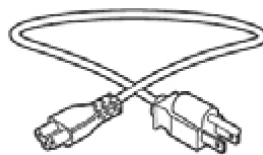

**Power Cord**

### Note:

1. Only use the AC adapter included in the machine. Using other AC adapters may damage the machine and void the warranty.
2. Please unpack the packing carefully, and check the contents against the checklist. If any items are missing or damaged, please contact us immediately by emailing [support@raven.com](mailto:support@raven.com) or calling +1-800-713-9009.

## Front View

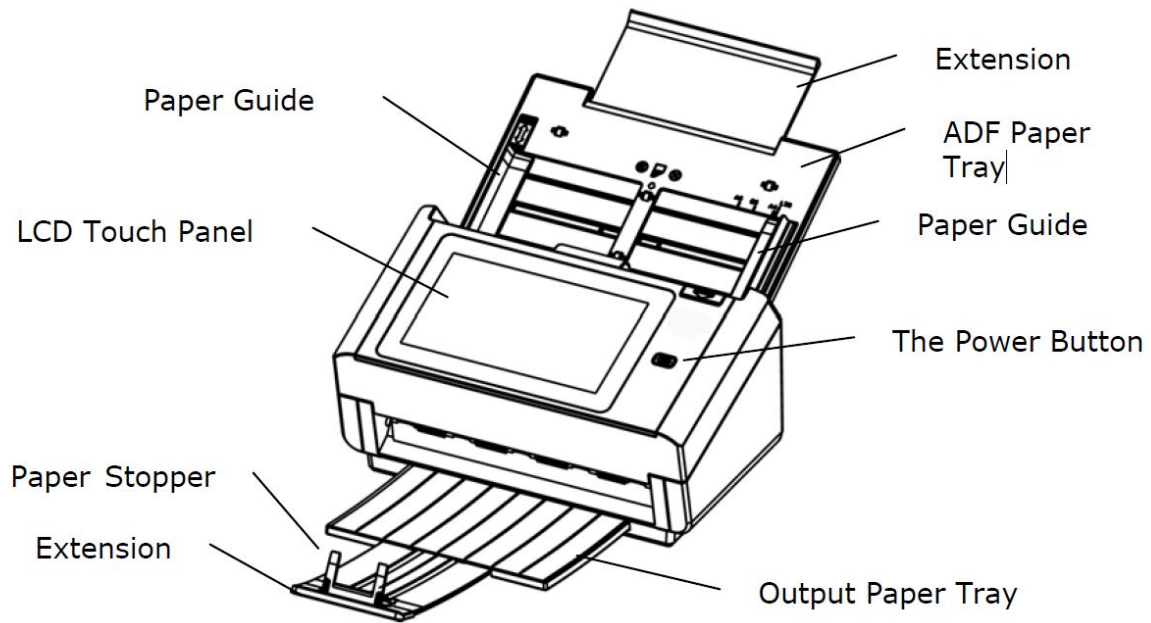

Part Name	Function
<b>Extension</b>	Can be pulled out and adjusted to the size of the document being scanned.
<b>ADP Paper Tray</b>	Load the document onto this part when scanning document.
<b>Paper Guides</b>	Adjusts to the width of the documents to prevent skewing of the scanned pages.
<b>LCD Touch Panel</b>	Operate the scanner through the touch screen.
<b>Power Button</b>	Press to turn on the power.
<b>Output Tray</b>	Open to collect the document after scanned.
<b>Extension</b>	Pull it out. Documents are ejected from the ADF to the tray.
<b>Paper Stopper</b>	Adjust to the length of the documents to prevent them from falling apart.

## Rear View

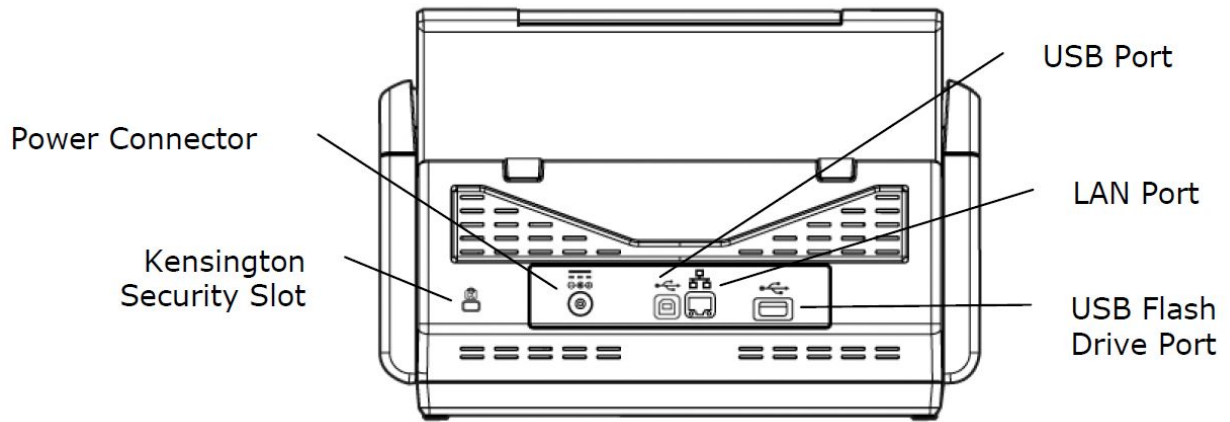

Part Name	Function
<b>LAN Port</b>	Connect the scanner to network with a LAN cable.
<b>USB Port</b>	Connect to your computer via a USB cable to use the device as a regular scanner.
<b>USB Flash Drive Port</b>	Connect your USB flash drive to this port.
<b>Power Connector</b>	Connect the AC adapter to the scanner.
<b>Kensington Security Slot</b>	Attach to a lock to secure the scanner.

## Side View

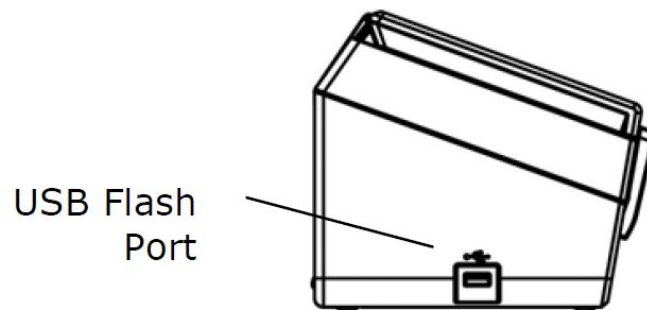

Part Name	Function
<b>USB Flash Drive Port</b>	Connect your USB flash drive to this port.

# Setting Up Your Scanner

## 1 Install the Scanner

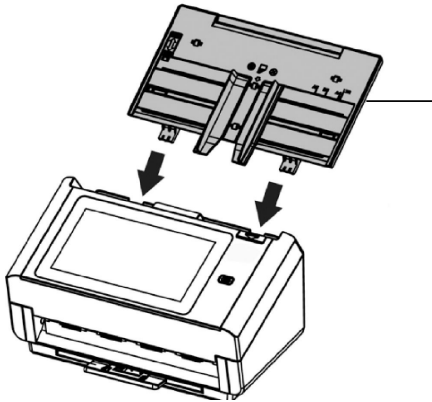

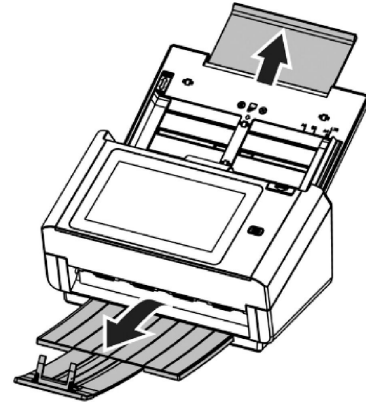

1.1 Hold the ADF Paper Tray and insert two pins to the holes on the top of the scanner as shown.

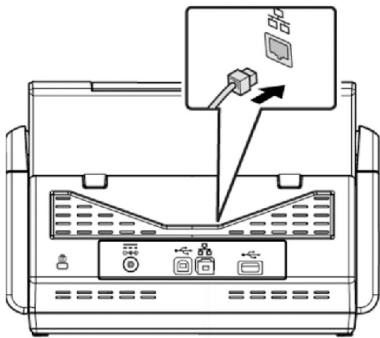

1.2 Pull out the extension to the length of the document. Pull the Output Tray and raise the paper stopper to prevent the paper from falling.

## 2 Connect to Power



2.1 (Optional) Connect one end of your cable Ethernet LAN cable to an available port of product. your Ethernet Hub, connect the other end to port marked  at the back of the product.

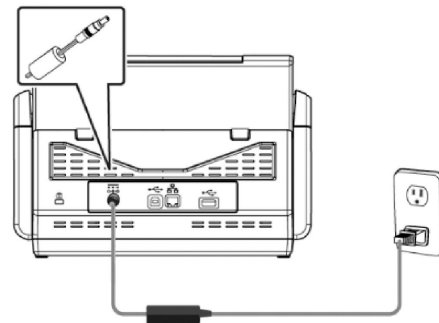

2.2 Connect one end of the power to the power receptacle of the Connect the other end to an appropriate power outlet.

## 3

Power on and get connected via ethernet cable or your preferred wireless network.

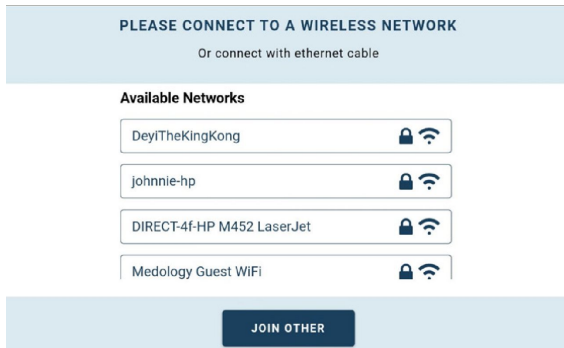

3.1 Connect to available wireless network

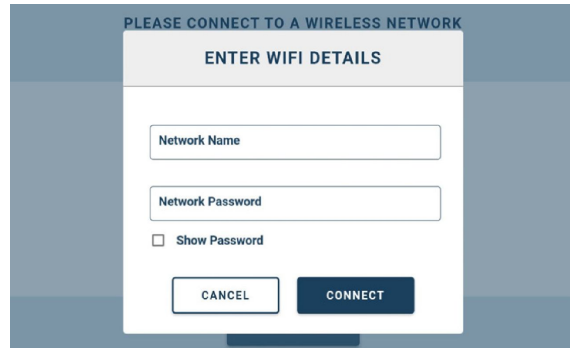

3.2 Or connect to other hidden network.

**4 Sign in to your Raven account. Sign up if you don't already have an account.**

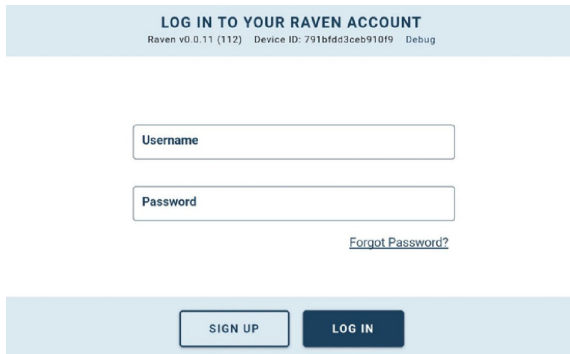

4.1 Sign in to your Raven account or sign up for free.

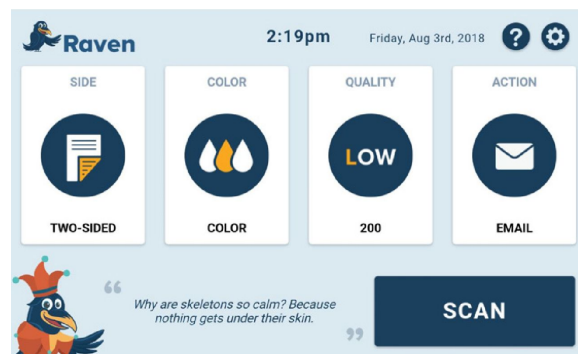

4.2 Welcome screen shows scan options and displays quotes for fun.

**5 Scan preview shows pages scanned. You can change upload destination options.**

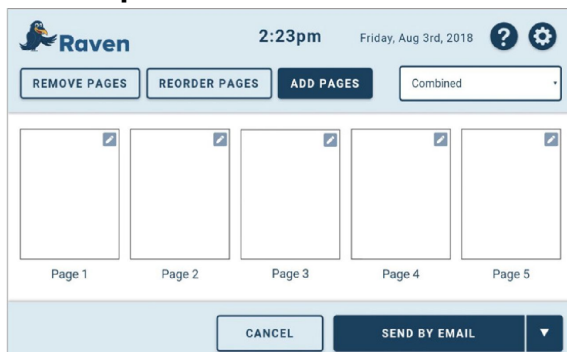

5.1 On scan preview screen, you can combine/separate files, rearrange pages, or change file destination.

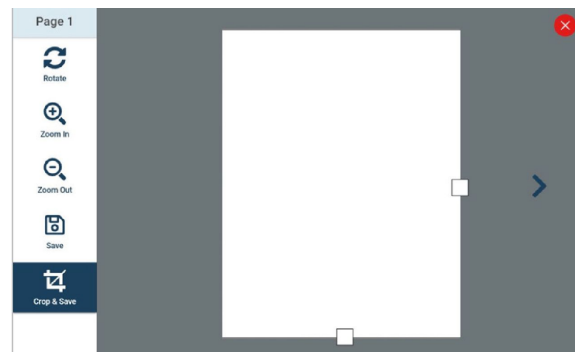

5.2 You can edit individual pages by clicking on preview thumbnails.

## Updating Your Scanner Software

To take advantage of the latest features and enhancements of your Raven Scanner, periodic updates are required. When connected to the internet, your Raven Scanner will automatically detect when new updates are available and prompt for installation. Simply follow the steps below to install the latest update.

1. When prompted that a new update is available, choose “Update”
2. After the update has finished downloading, choose “Install”, then “OK”. If prompted, choose “Install Manually”

## Turning Off Your Scanner

To put your scanner to sleep, simply press the “Zz” button on the front of the scanner. To power your scanner off entirely, flip the power switch to the off position on the rear of the scanner.

## Adjusting Scan Settings

Item	Description
<b>Sides</b>	<b>1 Side:</b> Choose to scan a single side of your document. Documents can be scanned face up or face down. <b>2 Sides:</b> If your original is a double-sided document, choose to scan both sides of your document.
<b>Color</b>	<b>Full Color:</b> The original is scanned in full color. This mode is best for full color originals such as pictures. <b>Black &amp; White:</b> Colors in the original are scanned as black or white. This mode is best for text-only originals. <b>Grayscale:</b> The colors in the original are scanned in black and white as shades of gray (grayscale). Most common setting.
<b>Scan Type</b>	<b>Separated:</b> Choose to scan each page as its own digital document. <b>Combined:</b> Choose to scan all document pages as a single digital document.
<b>Quality</b>	<b>Excellent:</b> Choose to scan at 600dpi (much slower scanning) <b>Great:</b> Choose to scan at 400 dpi (slower scanning) <b>Better:</b> Choose to scan at 300 dpi (slower scanning) <b>Good:</b> Choose to scan at 200dpi (good for most documents)
<b>Destination</b>	Choose one or more destinations where your scanned documents should be sent. <b>Raven Cloud:</b> Scan to your Raven Cloud document management account for searchable filing & organization. <b>Google Drive:</b> Scan to your Google Drive account (login required).

	<p><b>SharePoint:</b> Scan to your SharePoint account (login required)</p> <p><b>OneDrive:</b> Scan to your OneDrive account (login required)</p> <p><b>Dropbox:</b> Scan to your Dropbox account (login required).</p> <p><b>Evernote:</b> Scan to your Evernote account (login required).</p> <p><b>Box:</b> Scan to your Box account (login required).</p> <p><b>Email:</b> Scan to one or more email addresses.</p> <p><b>Fax:</b> Scan to a fax number.</p> <p><b>USB Drive:</b> Scan to a USB flash drive attached to the side of the scanner (FAT32 format required).</p>
<b>Page Preview</b>	<p><b>Page Preview:</b> Display previews of scanned pages for review and editing prior to sending to destinations.</p> <p><b>No Page Preview:</b> Skip the previews and send directly to destinations after scanning.</p>
<b>Blank Page Removal</b>	<p><b>On:</b> Scanned pages that do not contain content (blank) will be automatically removed from the final document.</p> <p><b>Off:</b> Scanned pages that do not contain content (blank) will be retained as pages in your final document.</p>
<b>Automatic Orientation</b>	<p><b>On:</b> Scanned pages that upside down will be automatically rotated in your final document.</p> <p><b>Off:</b> Scanned pages that upside down will be not be rotated in your final document.</p>

## Operation

### Document Loading Tips

Before using the ADF (Auto Document Feeder), please make sure that your paper meets the following specifications:

- Document(s) can range in size from 50 x 50 mm (2 x 2 in.) (A8) to 216 x 356 mm (8.5 x 14 in.) (Legal).
- Document(s) can range in weight from 7 to 110 lbs (27 ~ 413 g/m<sup>2</sup>)
- ID cards up to 1.25 mm (0.05 in.) thick
- Document(s) should be square or rectangular and in good condition (not fragile or worn).
- Document(s) should be free of curl, wrinkle, tears, wet ink, or punch holes.
- Document(s) should be free of staples, paper clips, paper sticky notes.

### Loading Document(s) in the ADF

#### Document Feeding

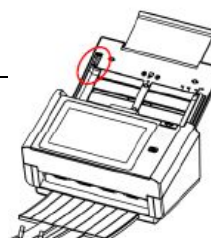

1. Load the stack of document **face down** with the top of the pages pointing into the feeder.
2. Verify that the paper guides are aligned with the edges of the stack by sliding the paper feed guides in the automatic feeder tray.

### Feeding Tips

To avoid occasional multi-feeds or paper jams, please fan your documents and align the top edges before feeding them into the scanner.

1. Hold both ends of the documents and fan them a few times.
2. Rotate the documents by 90 degrees and fan them in the same manner.
3. Align the edges of the documents in a step-like pattern (see picture).





## Scanning a Stack of Document with Various Sizes and Weights

When scanning a batch of documents with different sizes and weights, be sure to follow the following guidelines to avoid a skewed image or a paper jam:

1. Align the documents TOP EDGE first in the sequence of paper size from large to small.

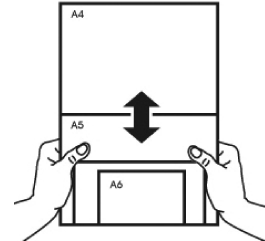

2. If two pages are of the same size yet with different weight, arrange these pages in the sequence of paper weight from heavyweight to lightweight.

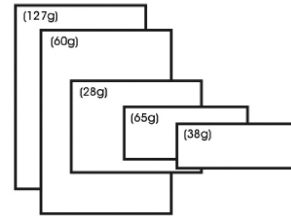

3. Align the edges of the documents by tapping the bottom of the stack against the table top.

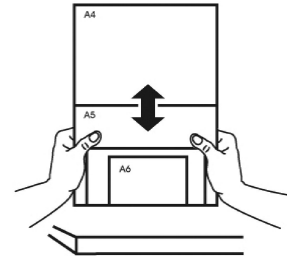

4. Center these pages in the document feeder and make sure that the edges of page of the largest size slightly touch the Paper Guide.

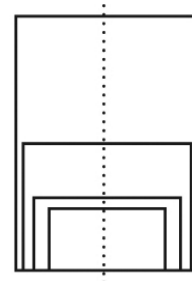

## **Editing Scanned Pages**

Scanned pages can be edited after scanning by tapping the page thumbnail edit icon, then selecting your edit options such as rotating or cropping. Choose “Save” when done.

To add pages to a scanned document, load documents into the document feeder, then choose “Add Pages” within the scan preview page to begin scanning.

To remove pages from a scanned document, choose “Remove Pages” within the scan preview page, then select the pages you would like to remove from the document.

To reorder pages within a scanned document, choose “Reorder Pages” within the scan preview page, then drag the page to the appropriate placement within the scanned pages.

To customize the name of a document, choose “Name Doc” within the preview page, then enter a single document title for combined documents, or individual document titles for separate documents.

## **Scanning and Sending Your Document to Raven Cloud**

1. Load the stack of documents with the top of the pages pointing into the feeder.
2. Verify that the paper guides are aligned with the edges of the stack by sliding the paper feed guides in the automatic feeder tray.
3. Select “Raven Cloud” as the Destination.
4. Press “Scan”.
5. Preview thumbnails of the scanned pages and make any necessary edits.

## **Scanning and Sending Your Document to E-mail Addresses**

1. Load the stack of documents with the top of the pages pointing into the feeder.
2. Verify that the paper guides are aligned with the edges of the stack by sliding the paper feed guides in the automatic feeder tray.
3. Select “Email” as the Destination.
4. Press “Scan”.
5. Preview thumbnails of the scanned pages and make any necessary edits.

## **Scanning Your Document to USB Flash Drives**

1. Insert a USB Flash Drive or External USB Hard Drive into the USB port on the left side of the scanner. Note: the USB drive must be formatted to FAT32 format.
2. Load the stack of documents with the top of the pages pointing into the feeder.

3. Verify that the paper guides are aligned with the edges of the stack by sliding the paper feed guides in the automatic feeder tray.
4. Select “USB” as the Destination.
5. Press “Scan”.
6. Preview thumbnails of the scanned pages and make any necessary edits.

## **Scanning and Sending Your Document to Google Drive**

1. Connect your Google Drive account within your account settings by visiting <https://app.raven.com/connect>
2. Load the stack of documents with the top of the pages pointing into the feeder.
3. Verify that the paper guides are aligned with the edges of the stack by sliding the paper feed guides in the automatic feeder tray.
4. Select “Google Drive” as the Destination.
5. Press “Scan”.
6. Preview thumbnails of the scanned pages and make any necessary edits.

## **Scanning and Sending Your Document to SharePoint**

1. Connect your SharePoint account within your account settings by visiting <https://app.raven.com/connect>
2. Load the stack of documents with the top of the pages pointing into the feeder.
3. Verify that the paper guides are aligned with the edges of the stack by sliding the paper feed guides in the automatic feeder tray.
4. Select “SharePoint” as the Destination.
5. Press “Scan”.
6. Preview thumbnails of the scanned pages and make any necessary edits.

## **Scanning and Sending Your Document to OneDrive**

7. Connect your OneDrive account within your account settings by visiting <https://app.raven.com/connect>
8. Load the stack of documents with the top of the pages pointing into the feeder.
9. Verify that the paper guides are aligned with the edges of the stack by sliding the paper feed guides in the automatic feeder tray.
10. Select “OneDrive” as the Destination.
11. Press “Scan”.
12. Preview thumbnails of the scanned pages and make any necessary edits.

## **Scanning and Sending Your Document to Dropbox**

1. Connect your Dropbox account within your account settings by visiting <https://app.raven.com/connect>

2. Load the stack of documents with the top of the pages pointing into the feeder.
3. Verify that the paper guides are aligned with the edges of the stack by sliding the paper feed guides in the automatic feeder tray.
4. Select “Dropbox” as the Destination.
5. Press “Scan”.
6. Preview thumbnails of the scanned pages and make any necessary edits.

## **Scanning and Sending Your Document to Box**

1. Connect your Box account within your account settings by visiting <https://app.raven.com/connect>
2. Load the stack of documents with the top of the pages pointing into the feeder.
3. Verify that the paper guides are aligned with the edges of the stack by sliding the paper feed guides in the automatic feeder tray.
4. Select “Box” as the Destination.
5. Press “Scan”.
6. Preview thumbnails of the scanned pages and make any necessary edits.

## **Scanning and Sending Your Document to Evernote**

1. Connect your Evernote account within your account settings by visiting <https://app.raven.com/connect>
2. Load the stack of documents with the top of the pages pointing into the feeder.
3. Verify that the paper guides are aligned with the edges of the stack by sliding the paper feed guides in the automatic feeder tray.
4. Select “Evernote” as the Destination.
5. Press “Scan”.
6. Preview thumbnails of the scanned pages and make any necessary edits.

## **Scanning and Sending Your Document to Fax Numbers**

1. Load the stack of documents with the top of the pages pointing into the feeder.
2. Verify that the paper guides are aligned with the edges of the stack by sliding the paper feed guides in the automatic feeder tray.
3. Select “Fax” as the Destination.
4. Press “Scan”.
5. Preview thumbnails of the scanned pages and make any necessary edits.

## **Scanning and Sending to Multiple Destinations**

1. Load the stack of documents with the top of the pages pointing into the feeder.
2. Verify that the paper guides are aligned with the edges of the stack by sliding the paper feed guides in the automatic feeder tray.

3. Select the “Destination” option on the home screen and choose your destinations by tapping the destination rows individually until you have selected all destinations where you would like to send your document, then choose “Save”.

## Using As A Regular Scanner

To use your Raven Scanner Pro as a regular scanner, you must first install the TWAIN and WIA drivers onto your computer. After installation of scanner driver is completed, this scanner allows you to scan via a TWAIN, or a WIA interface. Start your TWAIN-compliant image editing software application to select a TWAIN or WIA user interface. You may also launch Microsoft’s Scanner and Camera Wizard to scan via a WIA user interface.

To ensure your computer can identify the USB scanner, please install the scanner driver first before connecting the scanner to your computer.

## Installing The Driver and Connecting To The Computer

1. Visit [www.Raven.com/faq](http://www.Raven.com/faq) to download the Windows or Mac driver file
2. Complete the installation instructions to install the driver onto your computer
3. Connect the square end of the USB cable to the USB port of your scanner. Connect the rectangle end to the USB port at the rear side of your computer (not provided).

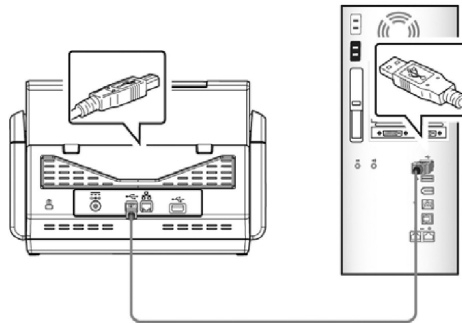

4. The computer should detect a new USB device and prompt a “New Hardware Found” message.
5. Follow any on-screen instructions, clicking the Next button to continue. If the certification screen appears, click Continue Anyway to complete the installation.
6. When the Finish dialog is prompted, click the Finish button.

# Troubleshooting

## Clearing Paper Jams

In the event of a paper jam, follow the procedures below to remove the paper:

1. Press the ADF Release Button on the right side. Gently open the Scanner Front Door to the left.
2. Carefully pull the paper out of the ADF unit.

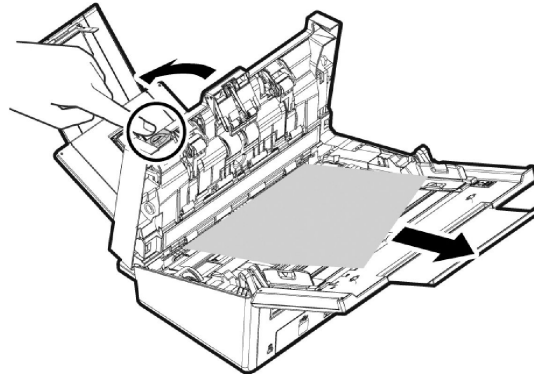

3. Close the scanner front door. Your Scanner is now ready to use.

## Questions and Answers

<b>Question:</b>	<b>Paper becomes jammed during scanning.</b>
<b>Answer:</b>	<ol style="list-style-type: none"><li>1. Open the front door.</li><li>2. Pull out the jammed paper carefully.</li><li>3. Close the front door</li></ol>
<b>Question:</b>	<b>More than one sheet of paper are fed into the scanner.</b>
<b>Answer:</b>	<ol style="list-style-type: none"><li>1. Open the scanner front door.</li><li>2. Remove the multi-fed sheets.</li><li>3. Close the front door.</li><li>4. Flatten the corners and edges. Loosen the paper before putting it into the paper guide again.</li><li>5. Check the feeding roller condition. If necessary, follow the cleaning directions and perform the cleaning.</li></ol>
<b>Question:</b>	<b>Paper becomes skewed in the scanner.</b>
<b>Answer:</b>	<ol style="list-style-type: none"><li>1. Use the slide guide to keep the paper path straight.</li><li>2. Check the condition of the feeding roller. If necessary, follow the cleaning directions and perform the cleaning.</li></ol>

# Maintenance

Your scanner is designed to be maintenance-free. However, constant care and maintenance can keep your scanner working smoothly.

## Cleaning The Touchscreen

Wipe the Touch screen Monitor with a wet cloth first then wipe it with a dry cloth.

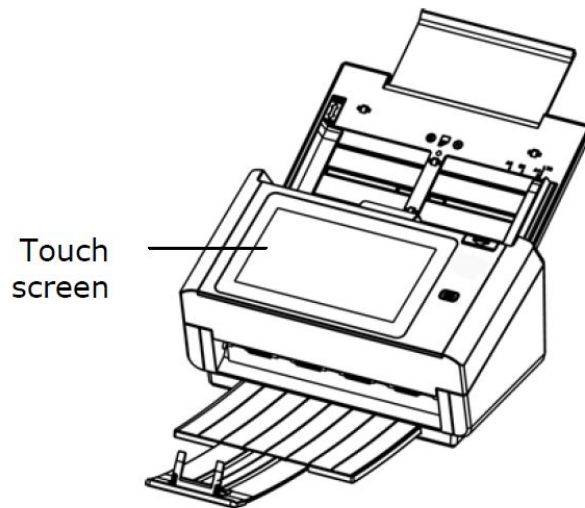

### **Warning:**

Do not use liquids, household cleaners, or neutral detergents, as they may damage the touch screen.

## Cleaning the ADF

After using the scanner for a long period of time, the rollers and glass inside the scanner may become contaminated with ink, toner particles or paper dust. It is necessary to perform routine cleaning to ensure the optimum image quality and performance. As a guideline, please clean the rollers and glass after first 4,000 to 5,000 scans and then perform the cleaning on a weekly basis. Note that the guideline varies according to the type of documents you are scanning.

**Tip!** If documents do not feed easily, if several documents feed at the same time or if streaks appear on the scanned images, it is time to clean your scanner.



## Cleaning Procedures

1. Soak a clean cloth with some isopropyl alcohol (95%).

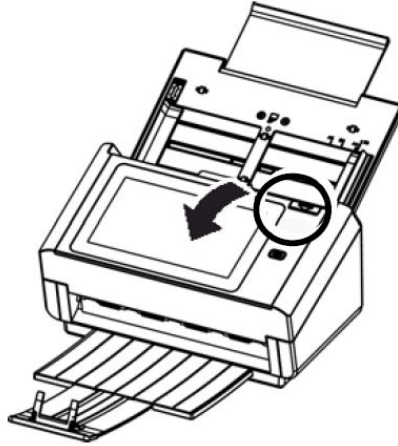

2. Press the ADF Release button to open the front door to the left. Wipe and rotate the ADF Roller until the surface is completely removed from dust.
3. Wipe the rubber part of the ADF pad. Be careful not to damage the pick springs.

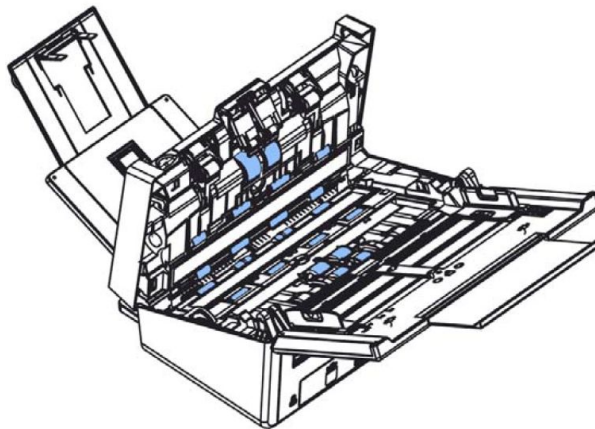

4. Close the scanner front cover. Your scanner is now ready for use.

## Cleaning The Glass

1. Press the ADF Release button. Open the front door to the left.
2. Wet a clean cloth with some isopropyl alcohol. (95%)
3. Wipe the glass and the white area as illustrated below to rid the dust or dirt.

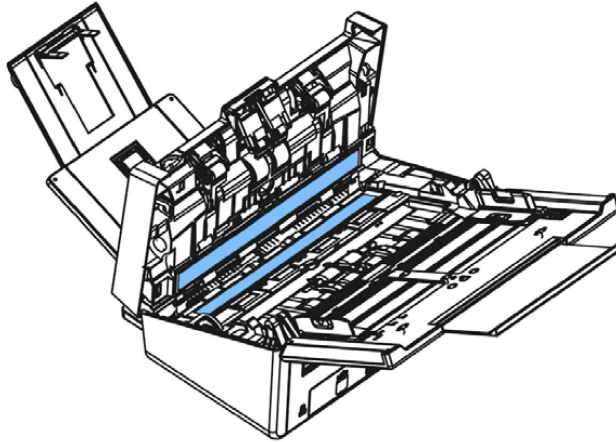

## Replacing the ADF Reverse Roller

After scanning approximately 100,000 pages through the ADF, the ADF Reverse Roller may be worn out and you may experience problems with document feeding. In this case, you may need to replace a new ADF reverse roller. For ordering the ADF roller, please email Raven support at [support@raven.com](mailto:support@raven.com) or call 1-800-713-9009 to order a replacement.

### Disassembling Procedure

1. Press the ADF Release button.
2. Gently open the ADF Front Door to the left.
3. Hold the Reverse Roller Cover with your fingers as shown and place it down.

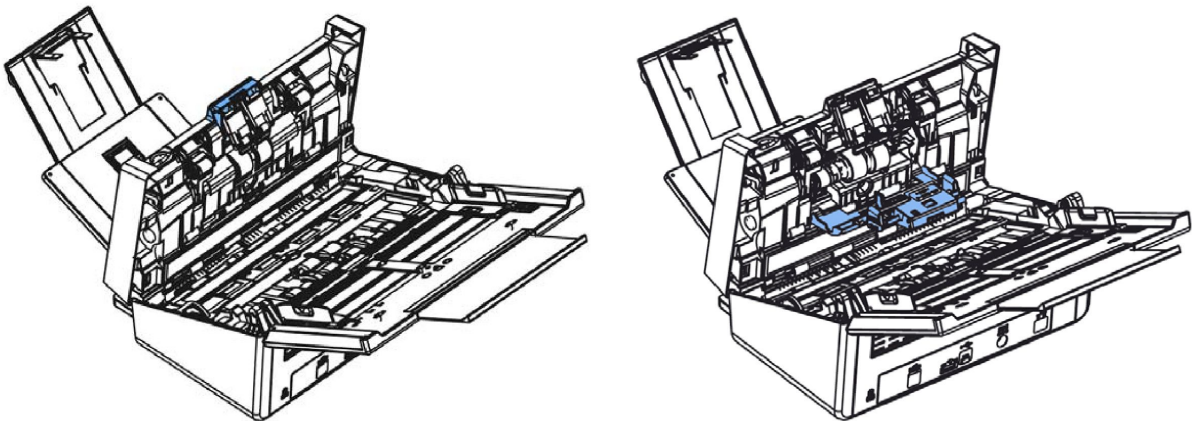

4. Press the right end of the Friction Roller externally to detach it from the slot and then detach the left end from its hole.

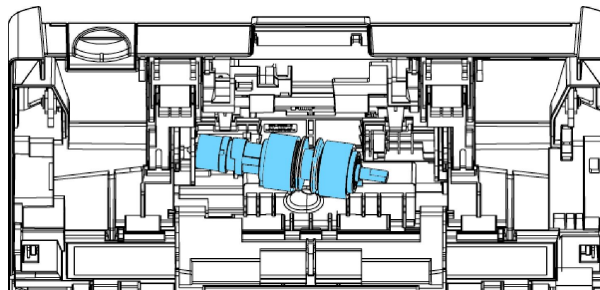

## Reassembling Procedure

1. Insert the left end of the Reverse Roller to the hole of its original place.
2. Insert the right end of the Reverse Roller to its slot.

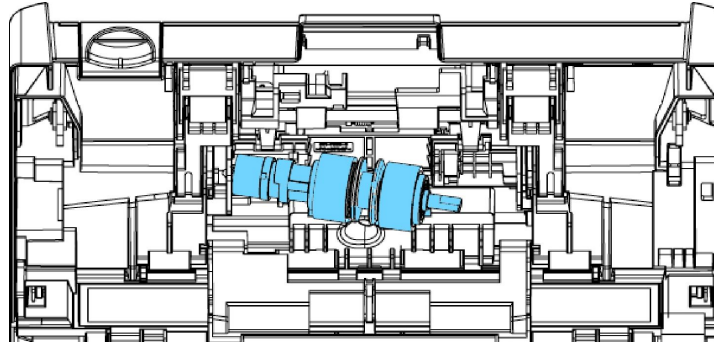

3. Close the Reverse Roller Cover.

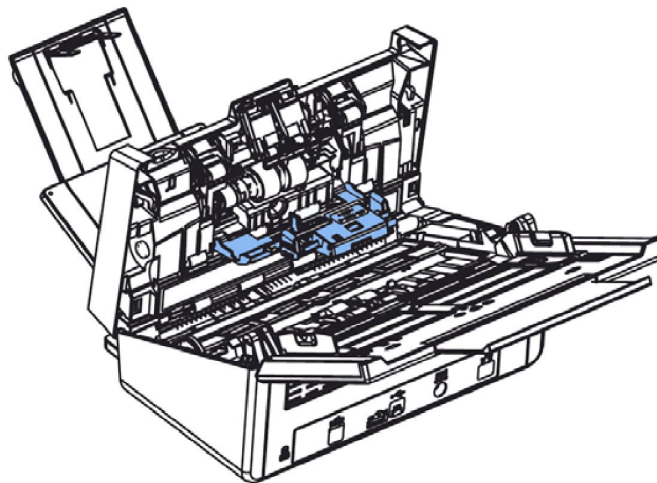

4. Close the ADF Front Cover.

## Replacing the ADF Roller

After scanning approximately 200,000 pages through the ADF, the ADF rollers may be worn out and you may experience problems with document feeding. In this case, you may need to replace a new ADF roller. For ordering the ADF roller, please email Raven support at [support@raven.com](mailto:support@raven.com) or call 1-800-713-9009 to order a replacement.

### Disassembling Procedure

1. Press the ADF Release button to open the ADF front door.
2. Pull the center of the ADF Roller Cover to open it.

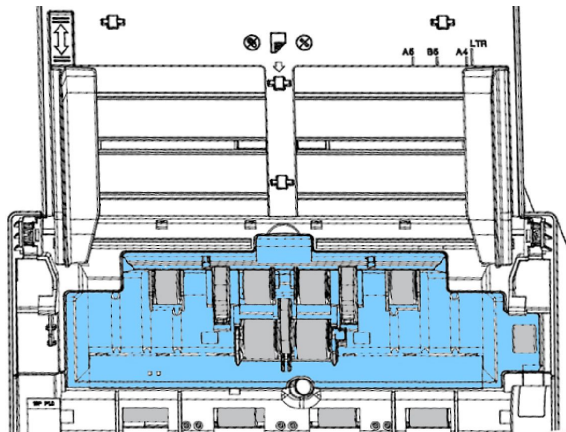

3. Move the tab of the ADF Roller **DOWN** as indicated.

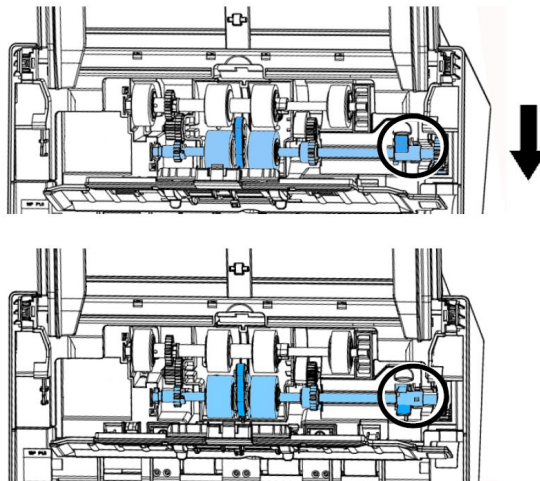

4. Detach the right end of the ADF roller from the scanner and remove the ADF roller.

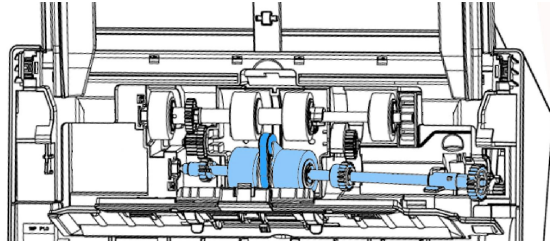

### Reassembling Procedure

1. Insert the left end of the ADF roller first to its slot and place the ADF roller to its proper position.
2. Make sure the belt in the center of the lower ADF roller is installed horizontally with the other rollers as indicated.

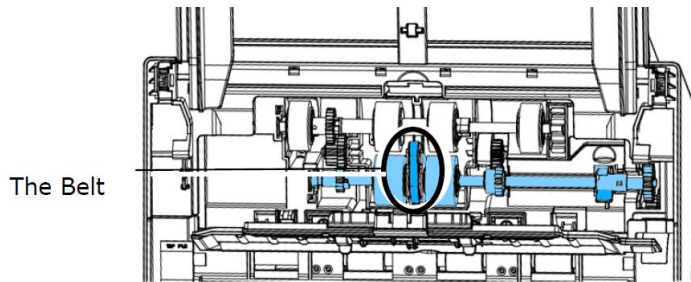

3. Move the tab of the ADF roller **UP**.

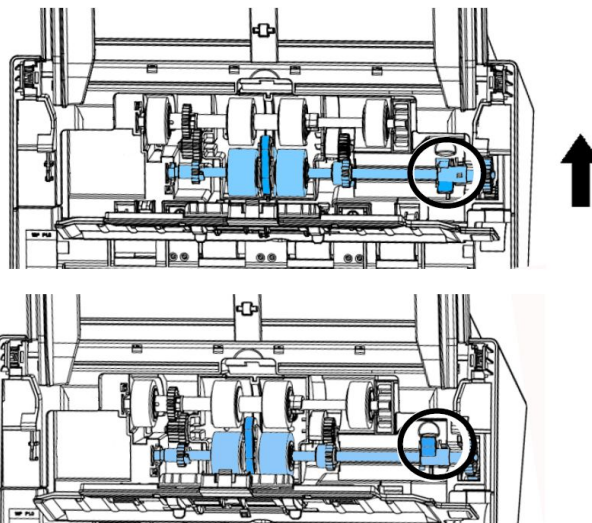

4. Close the ADF roller cover. A snap-in sound could be heard if correctly installed.

# Specifications

Description	Raven Scanner Pro
Scanner Type	ADF (Automatic Document Feeder), Duplex scanning
Multifeed Detection	Ultrasonic Sensor
Image Sensor Technology	Color Contact Image Sensor ( CIS ) x 2 (front x 1, back x 1)
Light Source	LED
Optical Resolution (dpi)	600
Document Feeder Capacity	Maximum 100 sheets (Legal, 413 g/m <sup>2</sup> or 110 lb)
Document Feeder Paper Sizes	Maximum : 9.5 x 14 in. Minimum : 2 x 2 in.
Daily Scanning Capability	6,000 sheets
Scanning Modes	Color, Grayscale, Monochrome (Black & White)
Long Page Scanning Capability	Up to 200 dpi Color Duplex 236 in. Up to 300 dpi Color Duplex 218 in. Up to 600 dpi Color Duplex 59 in.
ID Card Scanning	Minimum Size : 2 x 2 in., Maximum Thickness : 1.25 mm
Scanning Speed	Simplex : 60 ppm b&w/grayscale, 40 ppm color Duplex : 120 ipm b&w/grayscale, 80 ipm color
Scanner Size	12.4 x 8.1 x 7 in.
Scanner Weight	9.26 lb.
Touch Screen	8 in. LCD
USB Flash Drive Port	USB 2.0 (compatible with USB 3.0)
USB Computer Port*	USB 2.0 (compatible with USB 3.0) *Cable not included
Internet Connectivity	RJ-45 Ethernet 10/100/1000 Mb or Wi-Fi
Wi-Fi Standard	IEEE 802.11 b/g/n standards compliant
Wi-Fi Communication Mode	1T1R Mode
Wi-Fi Frequency Range	2.412 ~ 2.484GHz ( subject to local regulations)
Wi-Fi Security	WEP 64/128, TKIP, WPA, WPA2 mixed, 802.1x and 802.11i
Power Requirement	100-240V ~ 50-60Hz, 1.2A Max
Power Source	24Vdc, 2.0A
Power Consumption	Operation < 35 W, Ready < 20 W, Sleep < 3.6 W, Off < 0.4 W
Environmental Compliance	ENERGY STAR®
Operating Environment	Temperature (50°F~95°F), Humidity (10%~85% RH)
Driver	TWAIN for Win XP / Vista / Win 7 / Win 8 / Win 10 / Mac OS

**Included Items:** Raven Scanner Pro, AC Cable, AC Adaptor, Quick Guide, Ethernet Cable, Self-Inking Stamp  
For more Raven Scanner information, visit our website at: <https://www.raven.com/>

<b>Safety Precautions</b> 	Be sure to carefully read all safety precautions prior to using this product and use this device as instructed.	Do not place this device in wet, moist, steamy, dusty or oily areas. Using this product under such conditions may result in electrical shock, fire or damage to this product.
--	---	---

Specifications are subject to change without notice.

# Technical Support

Raven  
5821 Southwest Freeway  
Suite 600  
Houston, Texas 77057

1-800-713-9009

[support@raven.com](mailto:support@raven.com)

[www.Raven.com](http://www.Raven.com)