

BATLSKIN **viper**[™]A5

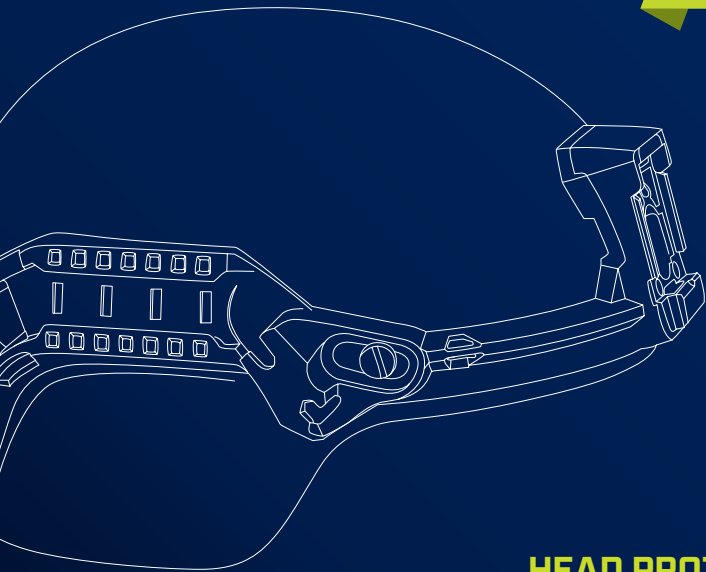

HEAD PROTECTION SYSTEM INSTRUCTION GUIDE

VIPER HEAD PROTECTION SYSTEM

TO THE OPERATOR – Duty calls and no matter the pace, obstacle or environment, your command wants you to be ready for whatever your mission throws at you. The Batlskin Viper® A5 Head Protection System was manufactured to meet stringent quality standards and is the ideal balance between reliable protection and exceptional value.

GALVION. EMPOWER YOUR MISSION.

PLEASE BE SURE TO READ ALL INSTRUCTIONS AND FOLLOW ALL WARNINGS. POOR SET-UP AND ADJUSTMENT MAY COMPROMISE THE SYSTEMS ABILITY TO PROVIDE THE PROTECTION THAT IT IS DESIGNED TO DELIVER DURING A BLUNT FORCE OR BALLISTIC IMPACT. SIZING, WARRANTY AND WARNING INFORMATION CAN BE FOUND BY SCANNING THE QR CODE.



HAVE QUESTIONS OR COMMENTS? CONTACT GALVION CUSTOMER SUPPORT
1-866-713-0406 | CUSTOMERCARE@GALVION.COM | GALVION.COM

CONTENTS

This manual provides information regarding the components of your Galvion Batlskin Viper® A5 Head Protection System. Galvion has developed the Batlskin Viper® A5 Head Protection System for blunt force and ballistic protection in a scalable lightweight package that's modular and integrated. It is important to follow the instructions on how to adjust your head protection system. Poor adjustment and over tightening of bolts may compromise the system's ability to provide the protection it is designed to deliver.

HELMET ANATOMY		FIT & CUSTOMIZATION		ACCESSORY COMPATIBILITY	
Viper A5 Helmet	4	Standard Retention System	9	Rail Adapters	25
Front Mount & Interlocking Long Rails	5	Standard Liner (7 Pad)	10	NVG Interface	26
One Hole Shroud	6	Modular Suspension System	12	Strap Extender For Mask	31
Liner Systems	7	Evaluating Helmet Fit	21	Care & Support	34
Standard Retention System	8	Adjustment and Fit	22		

VIPER A5 HELMET

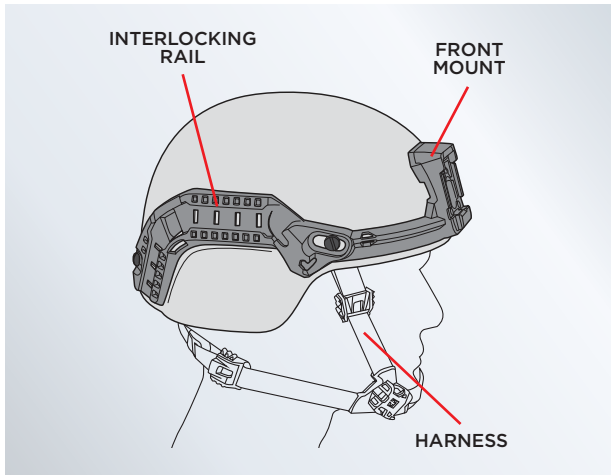

FRONT MOUNT & INTERLOCKING LONG RAILS

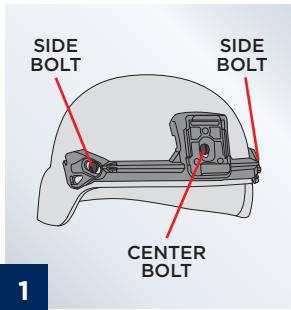

Use carriage bolt and t-nut to fasten center of Front Mount to helmet. Rotate center bolt so notch fits into slot.

Adjust position of Front Mount so it is centered on the helmet and sits above trim.

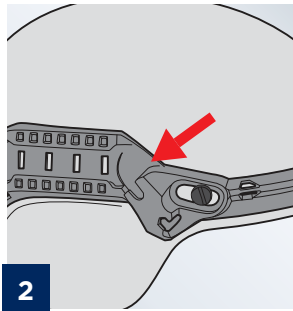

If using interlocking long rails, clip the rail behind the front mount side wing to lock together. Repeat for the other rail. If not installing rails, skip step 2 and proceed to step 3.

Adjust position of interlocking long rail so it is centered over the ear cup.

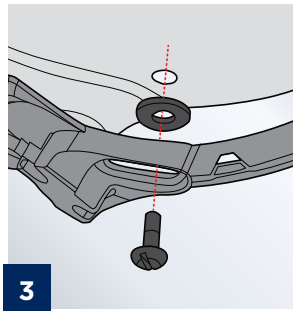

Use side bolts and t-nuts to secure sides of Front Mount, interlocking long rails (if applicable), washers and front retention straps.

To avoid cracking in the Front Mount, please use the supplied washers during installation.

ONE HOLE SHROUD

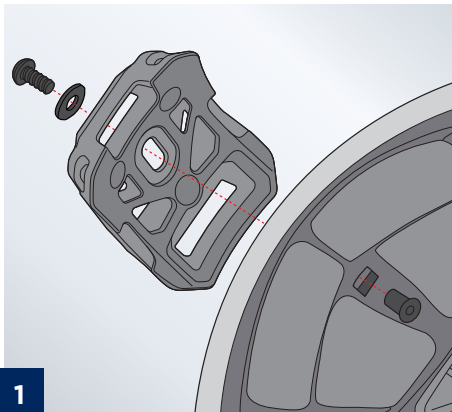

Insert nut in the center hole, thread bolt and washer through shroud and secure.

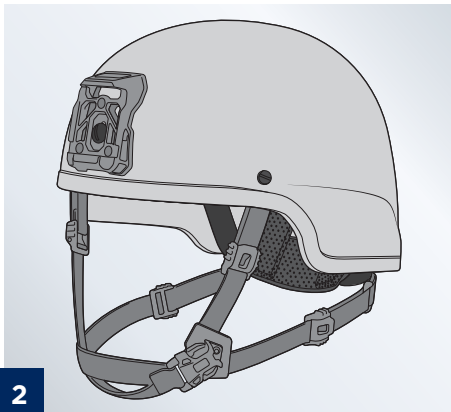

Position shroud so that it is level with the top of edge trim and fully tighten bolt so that shroud cannot be rotated.

LINER SYSTEMS

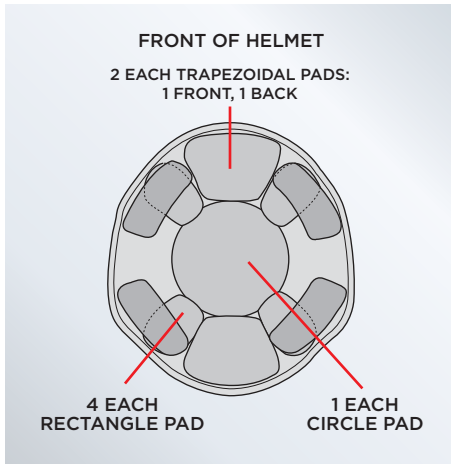

STANDARD LINER (7-PAD)

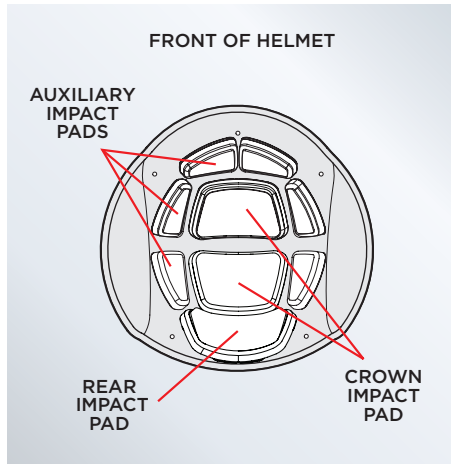

MODULAR SUSPENSION SYSTEM (MSS)

STANDARD RETENTION SYSTEM

INCLUDED

- 1 Retention System
- 4 Bolts and T-nuts

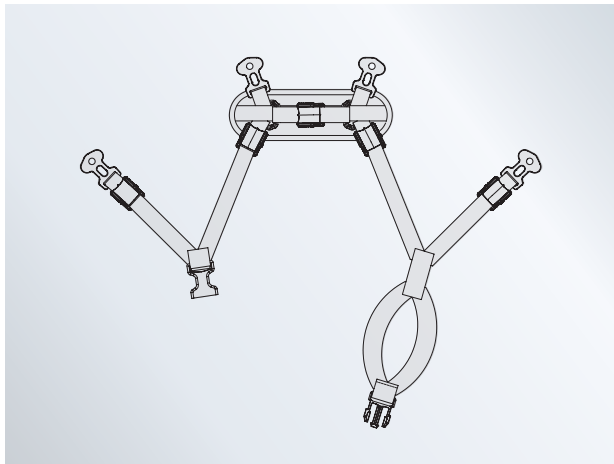

NOTE: To assemble your retention system, you will need a Flathead screwdriver or coin.

STANDARD RETENTION SYSTEM

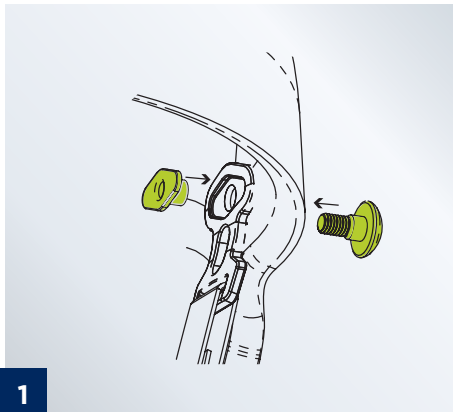

1 Place helmet flat on surface or in lap with inside of helmet facing up.

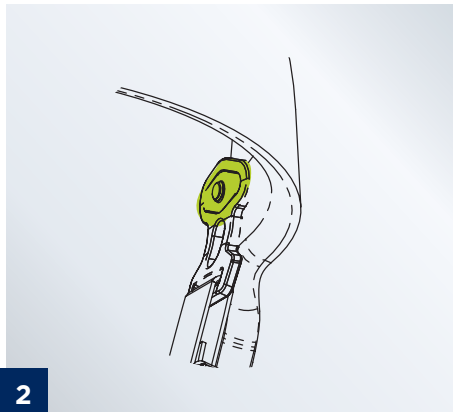

2 Fit ballistic t-nut into strap anchor and insert into hole of shell. Thread screw into t-nut and tighten. Repeat step 2 for remaining retention straps.

STANDARD LINER [7 PAD]

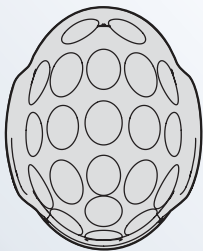

1

Place helmet flat on surface or in lap with inside facing upwards. Hook dots are pre-installed.

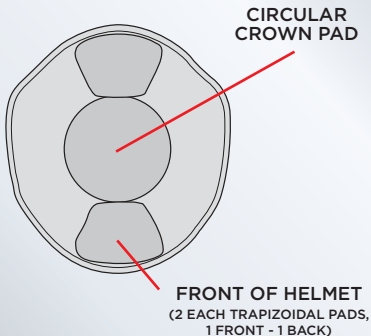

2

With loop-side down, place one trapezoidal pad at the front of the helmet and one at the back of the helmet. The widest ends of the pads should be flush with helmet brim.

Insert the circular crown pad loop-side down into the middle of the helmet.

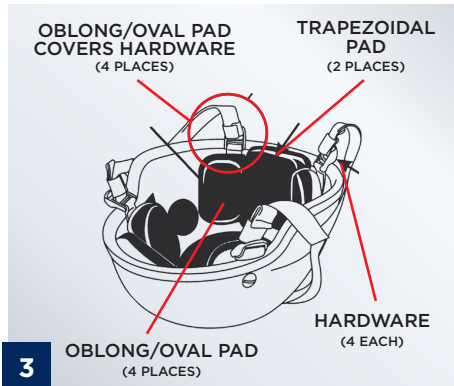

With loop-side down, place two oblong/oval pads on either side of each trapezoidal pad. The oblong/oval pads can be placed either horizontally or vertically, but must cover retention system hardware and be flush with helmet brim.

ENSURE PADS COVER RETENTION SYSTEM HARDWARE.

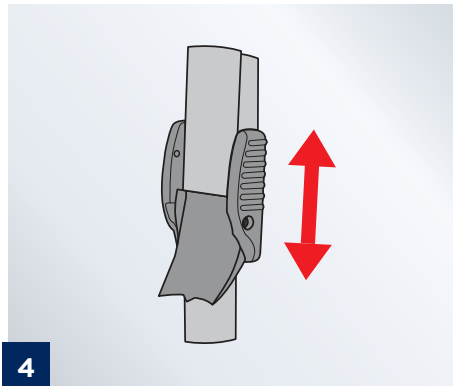

ADJUSTMENT AND FIT

With chin cup centered on chin, adjust nape pad, side and back straps using sliding tensioners.

Proper fit is attained when helmet sits level on head.

MODULAR SUSPENSION SYSTEM (MSS)

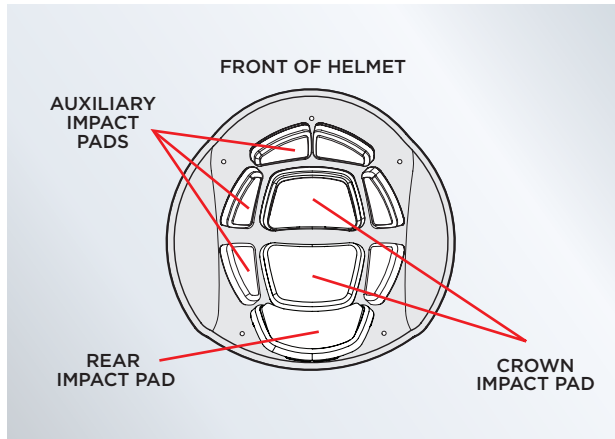

Place impact pads in the inside of the helmet shell in the configuration as shown above. Press firmly to adhere hook and loop.

The Modular Suspension System (MSS) comes with both a net and no-net option.

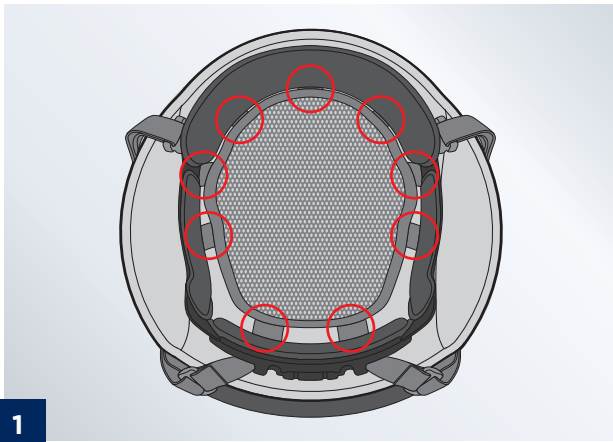

FOR NET OPTION

Once impact pads are installed, attach the net by adhering the hook and loop on tabs.

NOTE: For ease of installation, remove the rear impact pad and replace once rear of MSS has been installed.

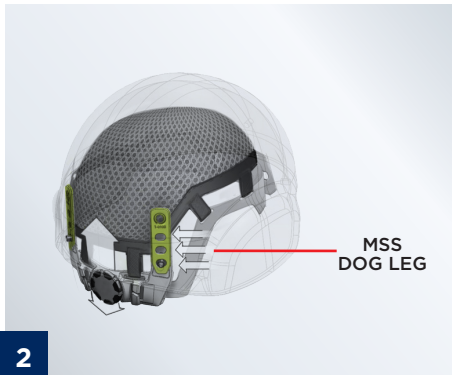

REAR HELMET HOLES

Insert a t-nut into one of the three holes in the nape dog legs, depending on the preferred height of the nape pad (most users prefer the middle option). Align the retention system strap with this hole and the hole of the helmet shell and secure by threading a bolt into t-nut. Repeat for the remaining rear hole.

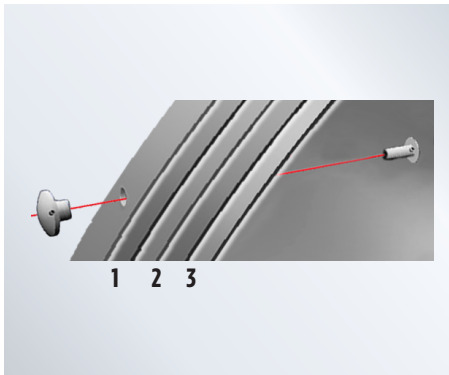

REAR BOLTS GOES THROUGH:

1. Helmet Shell
2. MSS Dog Leg
3. Retention System Strap Anchor

SECURE WITH A T-NUT.

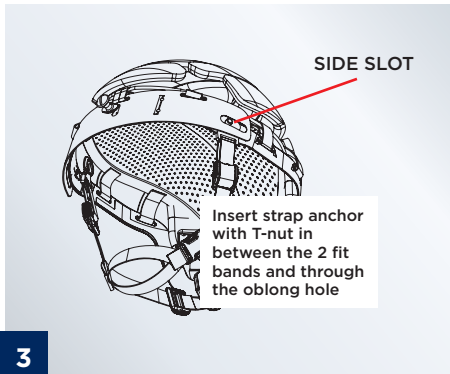

FRONT SIDE HELMET HOLES

If already installed, remove the comfort brow pad from the fit band. Align side slots of Front Mount and fit band with front holes in helmet shell. Insert a t-nut into front retention system strap anchor and fasten a bolt through Front Mount, helmet cover, shell and fit band. Repeat for remaining side helmet hole.

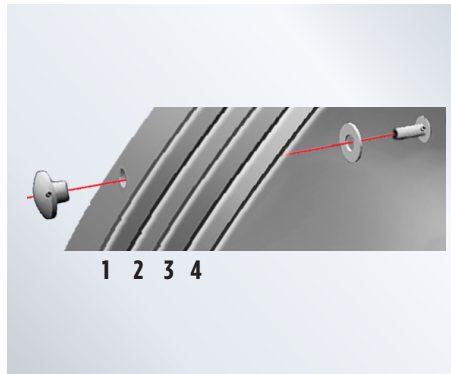

FRONT BOLT GOES THROUGH:

1. Front Mount
2. Helmet Shell
3. MSS Fit Band
4. Retention System Strap Anchor

SECURE WITH A T-NUT.

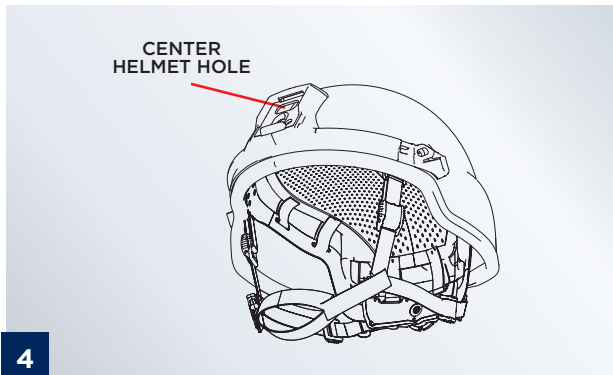

FRONT CENTER HELMET HOLE

Align center hole of Front Mount with center hole of helmet shell and fit band and insert bolt. Secure with t-nut. If removed in step 3, re-adhere the comfort brow pad on the fit band (largest edge towards the net). Tighten all bolts, ensuring that the t-nuts remain in the correct orientation in the retention system.

FIT AND ADJUSTMENT

The Modular Suspension System can be adjusted in five ways to ensure proper fit .

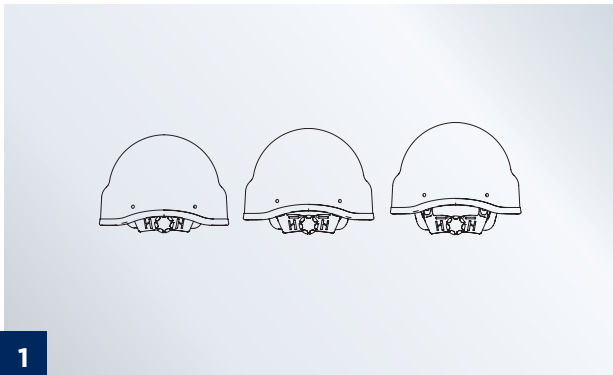

1 NAPE HEIGHT

Adjust the height of the retention system nape pad at the rear of the fit band by inserting the rear t-nuts into a higher or lower position on the dog legs. Users with larger heads may prefer a lower nape pad. When assembling the retention system for the first time, place the t-nuts into the middle hole and only move if required once all other adjustments have been made.

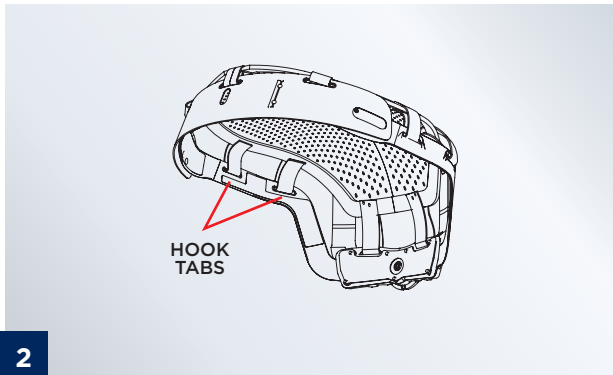

NET HEIGHT (FOR NET OPTION ONLY)

Adjust the helmet height by raising or lowering the net using the hook tabs. The net height should be adjusted so that the front brim of the helmet sits approximately 1/2" (12 mm) above the wearers' eyebrows and the head is not in contact with the impact liner. To confirm height of nape, tilt head back fully. If the dial touches your neck it is too low.

NOTE: If wearing an over-the-head communications headset, remove the comfort layer on the left and right sides of the fit band to accommodate the headset if need be.

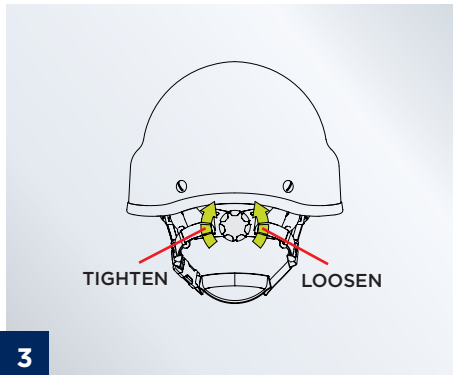

FIT BAND TIGHTNESS

On the rear of the fit band, turn the dial clockwise to tighten or counter clockwise to loosen the fit band around head.

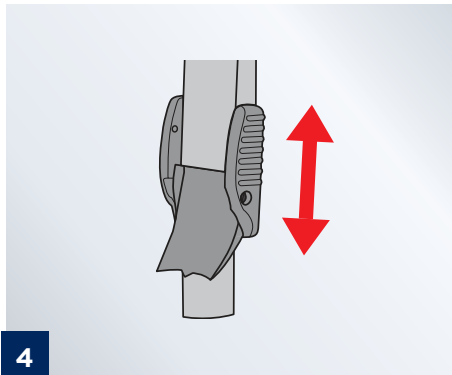

RETENTION SYSTEM

Open the strap tensioners completely and move them downwards to tighten or upwards to loosen. Adjust the back tensioners first, then the front ones. Close strap tensioners to lock.

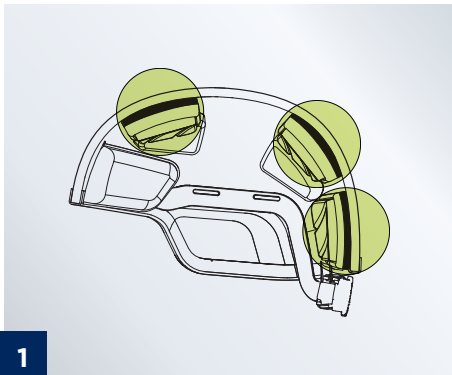
NO-NET OPTION**SHIMS**

For the no-net option, shims are available to customize helmet fit by increasing the thickness of the suspension system pads. To install shims, pull pads out of the helmet and affix shims. Press to adhere loop-side of shims to the hook-side of helmet.

**COMFORT LAYERS**

Install the comfort layers onto the two crown pads and rear impact pad. Stick the adhesive side of the comfort layer to the surface of the impact pad that comes into contact with head. Press to secure.

EVALUATING HELMET FIT

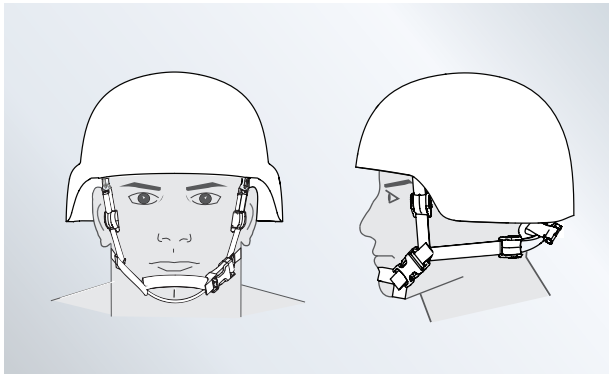

Helmet should sit approximately $\frac{1}{2}$ " (12 mm) above eyebrows and should cover ear canals.

Install retention system and 7 pad liner (refer to page 12) or MSS (refer to page 14). Once installed, don helmet and adjust retention straps.

Evaluate fit of helmet on head. If helmet is still too loose, try a smaller size. If too tight, try a larger size.

ADJUSTMENT & FIT

ISSUE	HOW TO EVALUATE THIS ISSUE	POSSIBLE SOLUTIONS FOR STANDARD RETENTION SYSTEM AND LINER	POSSIBLE SOLUTIONS FOR MSS
Helmet sits too high	More than 1/2" (12 mm) of forehead exposed above eyebrows When looking upwards with eyes only, cannot see helmet brim	Remove shims Still sits too high? The helmet may be too small, try a larger size	Remove shims and/or adjust net Still sits too high? The helmet may be too small, try a larger size
Helmet sits too low	Less than 1/2" (12 mm) of forehead exposed above eyebrows Helmet brim pushes down on eyewear	Add shims Still sits too low? The helmet may be too large, try a smaller size	Add shims and/or adjust net Still sits too low? The helmet may be too large, try a smaller size
Helmet is too tight	Helmet causes discomfort, pressure or hot spots In the lowest position, nape does not cup the rear of the head	Remove shims Still too tight? The helmet may be too small, try a larger size	Loosen fit band Still too tight? Adjust net and/or lower nape pad. Still too tight? The helmet may be too small, try a larger size
Helmet sits too loose	Helmet spins on head or moves excessively Liner pads are worn Retention straps are stretched due to extended use	Add shims and/or tighten retention system When the liner warms up, the pads compress, the retention system may need to be tightened If liner pads do not return to their original shape, they are worn out, replace the liner The retention system may be stretched due to extended use If it is fully tightened and still too loose, replace the retention system Still too loose? Try adding shims. If this does not help, helmet may be too large, try a smaller size	Tighten fit band and/or retention system Still too loose? Move nape pad higher If this does not help, the helmet may be too large, try a smaller size

ISSUE	HOW TO EVALUATE THIS ISSUE	POSSIBLE SOLUTIONS FOR STANDARD RETENTION SYSTEM AND LINER	POSSIBLE SOLUTIONS FOR MSS
Helmet is not stable	Helmet spins on head or moves excessively	Adjust nape pad Still not stable? Add shims If this does not help, the helmet may be too large, try a smaller size	Adjust height of nape pad Still not stable? Helmet may be too large, try a smaller size
Helmet is not level	Helmet does not sit level on head from left to right The front brim is not parallel to the ground	Loosen retention system straps and tighten them incrementally Use a mirror or get help from someone to ensure the helmet stays level while the straps are adjusted	Loosen all retention system straps and tighten them incrementally Use a mirror or get help from someone to ensure the helmet stays level while the straps are adjusted
Crown pad does not touch top of head	Cannot feel the crown pad touching the top of the head	Add crown shims or remove side shims Crown pad still not touching the top of the head? The helmet may be too small, try a larger size	N/A for net option For no-net option, try adding shims Crown pad still not touching the top of the head? The helmet may be too small, try a larger size



RAIL ADAPTERS

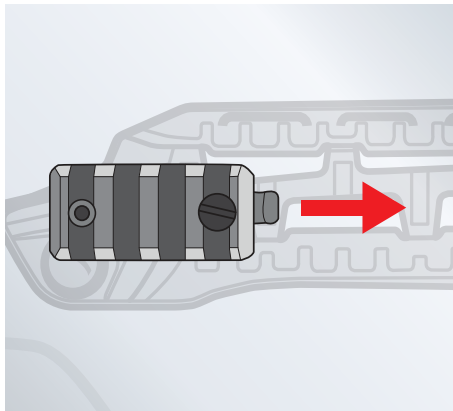

PICATINNY RAIL ADAPTER

Squeeze the end tab and slide the adapter onto rail channel tab—first. Once in the preferred position, release the tab and tighten the screw to secure the adapter in place.

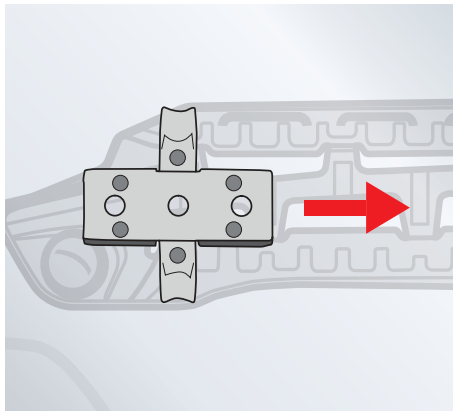

CROSS BASE RAIL ADAPTER

Attach the desired accessory onto the rail adapter. Tighten screws provided with the accessory to secure it in place. Pinch the tabs on either side of the adapter and slide onto rail. Release the tabs when in the preferred position.

CHANGING NIGHT VISION GOGGLE (NVG) INTERFACE

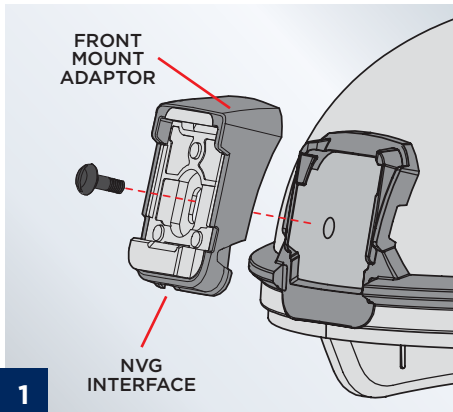

To change the NVG interface in the Front Mount, unscrew the center bolt and t-nut.

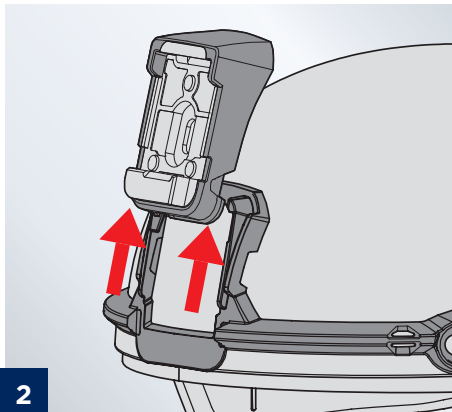

Remove the Front Mount adaptor by sliding it upwards.

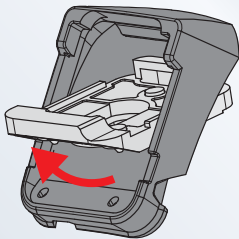
**3**

Push the bottom end of the NVG interface out of the adaptor.

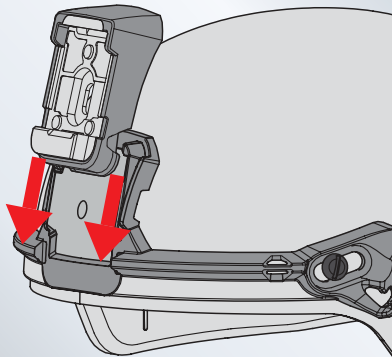
**4**

Insert the new NVG interface into the adaptor. Slide adaptor down into the Front Mount as shown.

Use center bolt and t-nut to fasten adaptor of Front Mount to helmet.

AFFIXING NIGHT VISION GOGGLES

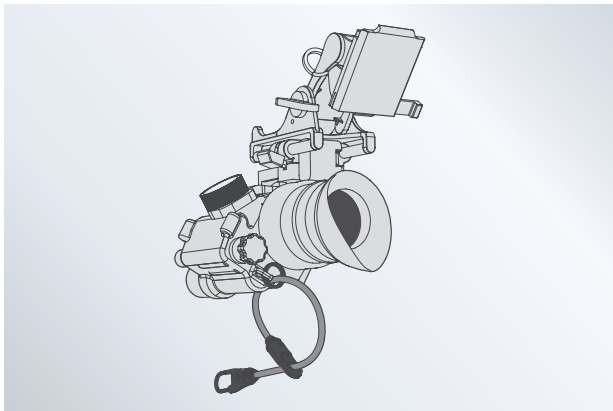

1. With helmet in lap, hold base of NVG attachment arm with two fingers and insert top half of arm into the front bracket of Front Mount.
2. Push bottom half of arm into NVG dock until it clicks into place. Ensure NVG arm is secure by pulling on it; the arm should not release.

FITTING THE SHOCK CORD TO THE HELMET & NVGS

This Head Protection System may be supplied with a shock cord to help support NVGs when they are fitted to the Front Mount and to secure the NVGs in case they are dislodged by a collision or fall.

The bungee cable is fitted with a friction clip to allow the user to adjust the length and the tension of the bungee.



ASSEMBLY

1. Attach the bungee mounted ring to the NVG device on the outside edge.
2. Attach the loose ring onto the NVG arm. Ensure both rings are secure and free to swivel and turn.
3. Attach the NVG arm to the Front Mount on the helmet.
4. Pass the bungee hook clip through the NVG spring clip and then attach the hook clip to the Front Mount securing point on the same side of the helmet where the NVG will be used, e.g. left side if being used with the left eye.
5. Tension loosely until NVG has been tested for position, then tension more to reduce any shaking in the NVG by sliding the friction clip up towards the pivot point of the arm.

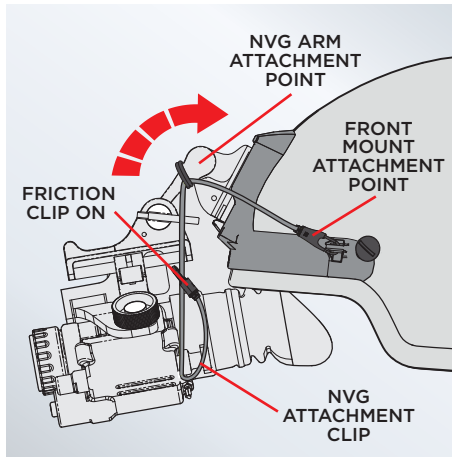

STRAP EXTENDER FOR MASK

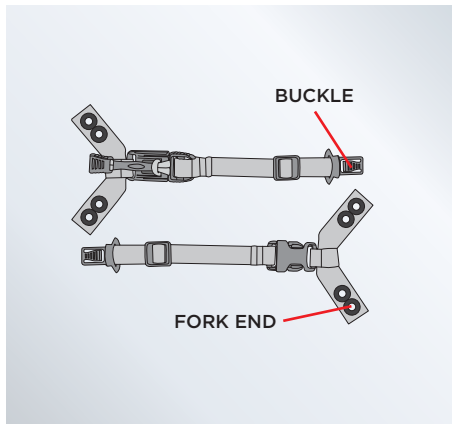

INCLUDED

- 1 Left Strap Extender
- 1 Right Strap Extender

NOTE: Depending on type of mask used, fork ends may be installed either on the outside of the mask's plastic housing or underneath between the housing and the rubber face mask.

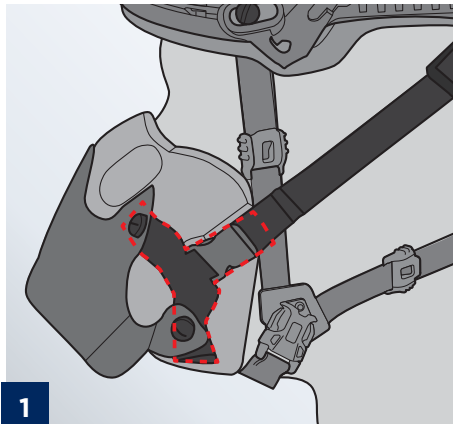

Using the hardware provided with the mask, install the fork ends of the Strap Extender on either side of the mask.

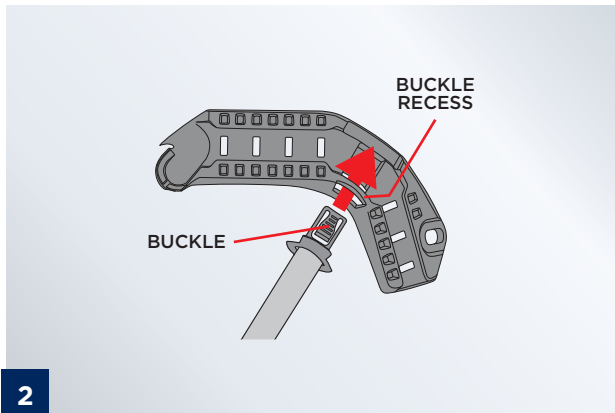

Don the helmet and mask. Clip the buckle of the Strap Extender into the recess located in the middle of the rail. Repeat for the other side.

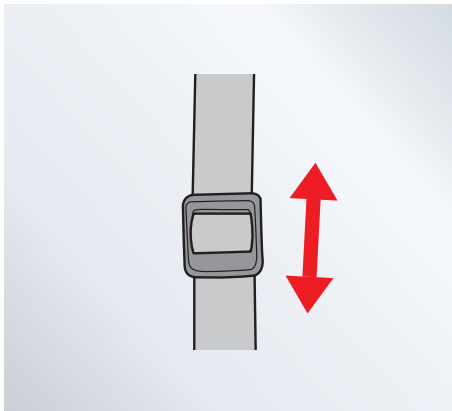

ADJUSTMENT: To adjust the length of the straps once clipped to the rails, use ladder-lock to loosen or tighten straps.

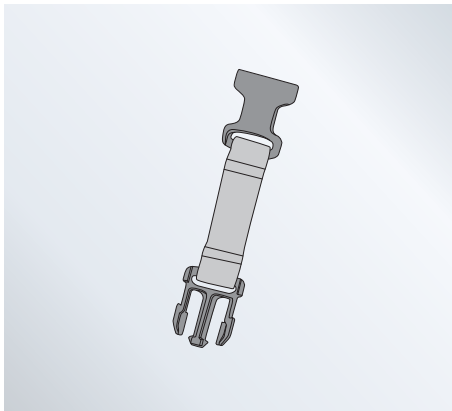

CBRN RETENTION SYSTEM STRAP EXTENDER

If using a CBRN mask, a strap extension can be used to lengthen the retention system straps by clipping the buckle of the strap extension to the retention system buckle.

CARE & SUPPORT

ONE-TIME EVENTS

If a severe impact damages the helmet resulting in dented or flattened areas, the helmet performance might be reduced. The helmet system should be replaced.

RECOMMENDED MAINTENANCE: ALL USERS

1. Clean the helmet with a mild detergent and water
2. Check that the retention system bolts are tight using a flathead screwdriver
3. Clean the Velcro to remove dust and dirt by using air pressure
4. Visually check the shroud and rails for signs of breakage
5. Visually check the fit band for signs of breakage
6. Check that the rear dial on the fit band works properly
7. Check that the retention system does not have any damage, that the buckle and strap tensioners open and close properly

IF ANY DEFECTS ARE DETECTED, THE DAMAGED COMPONENTS MUST BE REPLACED BEFORE USE.

RECOMMENDED MAINTENANCE: HIGH OPERATIONAL INTENSITY (DEFINED AS SOLDIERS WHO USE THEIR HELMET 1100 HOURS/YEAR OR MORE)

1. Replace fit band, comfort pads, cover and harness every 6 months but at minimum once/year
2. Replace hardware and EPP pads after 2 years
3. Repaint shell after 4 years
4. Replace other components if damaged/worn out as needed

RECOMMENDED MAINTENANCE: MEDIUM & LOW OPERATIONAL INTENSITY (DEFINED AS SOLDIERS WHO USE THEIR HELMET 1100 HOURS/YEAR OR LESS)

Inspect helmet system every 6 months and replace damaged and worn components as needed.

- **FIT BAND:** Replace if the plastic is broken or the dial no longer tightens and holds the helmet secure to the users' head
- **COMFORT PADS:** Replace if the padding is exposed because the cover is ripped or torn, or padding is very compressed and does not return to its original shape when pressed with a finger.
- **HARNES:** Replace if the webbing is torn, strap tensioners no longer hold the straps tight, the side squeeze buckle is broken or the strap anchor threads are stripped
- **COVER:** Replace if it is torn, the Velcro no longer attaches the cover securely to the shell or it is faded
- **EPP:** Replace if the EPP is dented with flat parts, if pads are missing or the Velcro on the pads no longer holds them securely to the shell
- **BOLTS:** Replace the hardware if the bolts are stripped or broken
- **SHELL:** Repaint the shell if the paint is chipped, scratched or flaking, exposing the ballistic material underneath. Replace the Velcro if it no longer holds the EPP or cover securely in place.

HAVE QUESTIONS OR COMMENTS? CONTACT GALVION CUSTOMER SUPPORT
1-866-713-0406 | CUSTOMERCARE@GALVION.COM | GALVION.COM



©2021 GALVION INC. ALL RIGHTS RESERVED. GALVION™, BATLSKIN® AND BATLSKIN VIPER® ARE TRADEMARKS OF GALVION INC. OR ONE OF ITS AFFILIATES.
GAL3036_0521 EN 5-0008-0052 REV D