



User Manual v3.2

Check www.UrbanDrones.com
for the latest version of this
manual and firmware updates
for your drone and camera.



Get Help at
UrbanDrones.com
or call us at:
954-213-4977

SwellPro
www.UrbanDrones.com

Thank you for purchasing the SwellPro Spry. We have designed and manufactured the Spry to the highest quality standards.

Like any marine equipment, long-life and trouble-free operation relies on due care and maintenance. With proper care and maintenance you should enjoy your drone for many years. After flying in salt or contaminated water, always thoroughly rinse and dry your Spry in fresh water immediately after use or before salt and sediment can dry inside moving parts.

It is important to familiarize yourself with the features of this unique drone by carefully studying this manual and particularly the priority sections indicated in the Table of Contents. Check www.swellpro.com for the latest manuals, software and tips. Refer to the Version Information section at the end of this manual which details additions and corrections to this manual.

Reading Notes

Icons Used in This Manual



Read first



Prohibited



Important Notice



Operating Tip

Other Information

Visit and subscribe to SwellPro's YouTube channel for instructional videos and product information.



www.facebook.com/UrbanDrones/

Register your Product Warranty

Please ensure you register your product as soon as possible to ensure warranty coverage.

www.UrbanDrones.com/



Contents

Reading Notes	02
Product Overview	05
Brief Introduction	05
Highlighted Functions	05
Safety Operation Guidelines	06
Disclaimer And Warning	06
Drone Illustrations	07
Remote Controller Illustrations	08
FPV Screen	09
About the Drone	09
Flight Modes	10
Return Home	11
Drone Indication Lights	12
Propellers	12
Micro SD Card Installation	13
Battery	14
Battery Installation	14
Low Battery Alarm	15
Low temperature precautions	15
Remote Controller	15
Charging Remote Controller Battery	15
Low Battery Alarm	16
Remote Controller Operation	16
Remote Controller Pairing	18
Camera	19
Camera	19
Camera Settings and Use	19

Flight	21
Introducing you to Flying a Drone	21
Flying the Spry	21
Flight Restrictions	21
Preparation Before your First Flight (or in a new location)	22
Gyroscope (Accelerometer) Calibration	22
Compass Calibration	23
Starting / Stopping the Motors	23
Basic Flight Steps	25
Water Take-offs and Landings	26
Power-Flip	26
Take-ofs and Landings from a Boat	26
APP Control	27
How to Use	27
Tap to Fly	28
Flight Path Setting	29
Appendix	30
Specifications	30
Warranty Information	31
FLIGHT BATTERY -Safety Guideline	32
Safety Operation Guideline & Disclaimer and Warning	35
Safe Operation Guidelines	35
Disclaimer and Warning	38
Version Information	39

Product Overview

This section introduces the various drone functions, how to assemble the drone, the various part names of the drone, and its remote controller.

Brief Introduction

Spry is the first-ever compact & portable waterproof sports drone.

Its fully waterproof fuselage and built-in camera helps you capture photos and 4K/30fps video in all weather conditions. The competitive power system allows you to experience high speed flight over water - enjoying true freedom.

Highlighted Functions

1. The Spry fuselage and remote controller are waterproof and suitable for all-weather, all-terrain cruising.
2. The aerodynamic shape of the whole drone is designed to effectively minimize wind resistance and improve flight speed.
3. Spry's camera uses a Sony 1 / 2.3 inch CMOS sensor matched to a lens that minimizes fisheye distortion to obtain natural-looking scenes. Use your Spry to record stunning 4K video at 30 frames per second or take high-definition 12MP photos.
4. Adjustable lens angle: The Sprys camera can be tilted up and down with the remote controller to frame your videos better.
5. Optional electronic stabilization system helps ensure smoother footage.
6. The Spry 4K waterproof camera is sealed in an optical glass dome to protect the camera lens from damage. The specially designed dome has high transparency without distortion and also helps avoid excessive glare.
7. Intelligent Follow Me: The Spry uses a built-in motion algorithm to follow the position of the remote controller. The follow me functions supports leading or following camera positions.
8. Target orbit: the Spry can perform an autonomous orbit around a moving object.
9. Auto return: The Spry constantly monitors the location of the remote controller so that it can return to the last-known position of the pilot in case of radio interference or a return-home command.
10. APP smart control: One Key Take Off | Point to Fly | Orbit Fly | Auto Return | Flight Path Settings
11. Easy to use.

Safety Operation Guidelines

- Please make sure you have a comprehensive understanding of the Spry and all the necessary measures required to implement a successful return home function in the event of an emergency.
- Please be well prepared before each flight, charge batteries and understand the flying area.
- Please follow local laws and be aware of NO-FLY ZONES and other restrictions.
- It is your duty to comply with the local laws regarding privacy protection.
- Do not fly around objects that may emit strong magnetic fields such as radio masts, electricity towers, high-voltage transmission lines, transformer substations, radar and large metal structures.
- Do not fly the Spry under the influence of alcohol, drugs or any other physical or mental impediment.
- Don't fly the drone if it is damaged or malfunctioning.
- Always fly a drone away from crowds.

Disclaimer and Warning



This product is not a toy, and should only be operated by persons over the age of 18. Please keep it out of reach of children, and pay particular attention to the possible scenarios of children unexpectedly appearing during flight operations.

Be sure to read this document carefully before using the product to fully understand your legal rights, responsibilities and safety instructions. Failure to do so may cause property damage, accidents and personal injury. Once this product is used, it is deemed that you have understood, recognized and have accepted all the terms and conditions of this statement. The user is responsible for all the consequences of his actions and the use of the product. The user agrees to use the product for his sole & legal purpose, and agrees with the terms & conditions of this agreement, and other relevant policies & guidelines that may be specified by SwellPro.

Under the maximum permission by law and approved circumstances, SwellPro is exempt of liability for any indirect, punitive, consequential, special or criminal damages, including the purchase cost, or for loss of income due to the loss of use of the drone.

SwellPro is exempt from the user's liabilities for damage(s) to person/s or property, or injuries incurred directly or indirectly from the use of this product.

SwellPro reserves all rights for final interpretation.

1st Drone Illustration

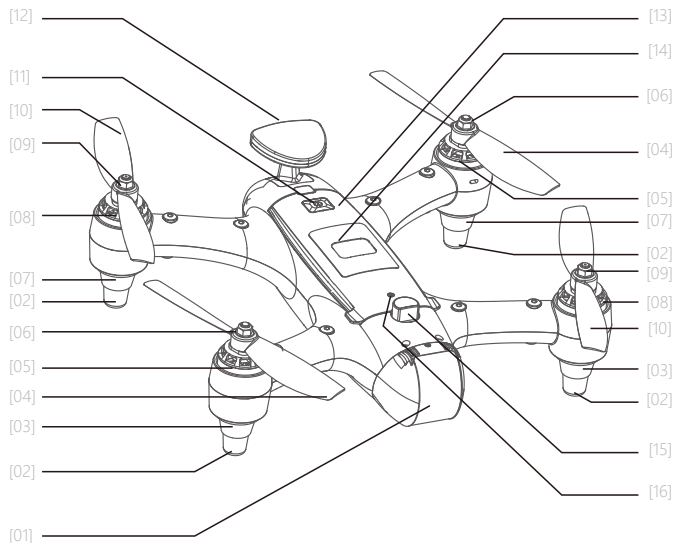

[01] Camera Lens Cover

[02] Rubber Feet

[03] Drone Nose Lights

[04] CCW Propeller

[05] CCW Motor

[06] CCW Propeller Nut

[07] Drone Status Lights

[08] CW Motor

[09] CW Propeller Nut

[10] CW Propeller

[11] Power Button

[12] GPS pod

[13] Battery Cover

[14] Ventilator Film

[15] Battery Cover Lock

[16] Battery Cover Mount

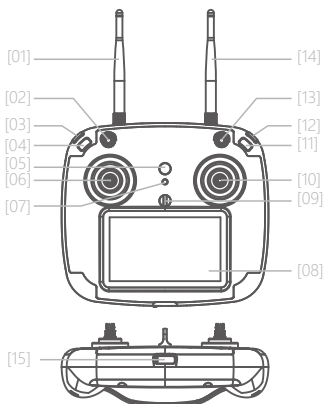

- | | | |
|---|---|--|
| [01] 2.4G Remote Antenna
For drone control signal | [06] Left Joystick
Control the drone's ascent (up), descent (down) and/or to rotate the aircraft nose left or right. | [11] Camera Button
Used for controlling Video and Photo functions. |
| [02] Return-Home Switch
Commands the drone to return automatically | [07] FPV Channel Button
Press and hold to search for the best FPV channel | [12] Camera Up Button
Tilts the camera up |
| [03] Camera Tilt Down Button
Tilts the camera down | [08] FPV Screen
Displays flight data and FPV video | [13] Flight Mode Switch
GPS / Circle / ATTI |
| [04] Follow Me Button
Controls the drone to follow the remote controller | [09] Hanger Ring
Attachment point for neck lanyard | [14] 5.8G FPV Antenna
Receives FPV live video 5.8GHz |
| [05] Power Button + Controller Status Light
Press and hold to power on the remote controller. The button will glow to indicate remote controller status. | [10] Right joystick
Controls the drone direction of flight | [15] USB Port/Vent plug
For charging the remote controller battery and performing firmware upgrades |

⚠ Before powering on the controller, please be sure to put all the toggle switches on the controller in the up position.

⚠ As the remote controller is completely sealed, the air inside is subject to changes in pressure and temperature. If the rubber joystick seals balloon or suck in, simply equalize the pressure inside the remote by briefly opening the USB charge plug.

Note: The default remote control configuration is left hand as throttle. If you prefer to have right hand throttle, please consult your local dealer.

Display Interface

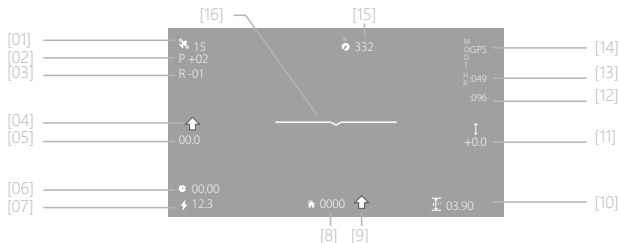

[01] GPS satellites tracked	[07] Drone battery voltage	[13] Current throttle
[02] Angle of aircraft pitch	[08] Distance from the take off point	[14] Flight mode
[03] Angle of aircraft roll	[09] Home point direction relative to drone	[15] Compass bearing
[04] Flight direction	[10] Vertical height	[16] Flight attitude
[05] Flight speed	[11] Vertical speed	
[06] Flight time	[12] Remote controller signal strength	

⚠ If [04] and [09] both point in the same direction, the drone is flying towards to remote controller/home point.

About the drone

This section introduces the drone and its functions.

Flight Modes

The Spry utilizes a brand new flight control system which incorporates 5 of the best flight modes.

GPS mode: This mode uses the GPS module to achieve accurate and stabilized hovering, braking, intelligent flight, intelligent return and other intelligent flight mode functions. In this mode, maximum flight speed is 10m/s, maximum ascent speed is 4m/s, and maximum descent speed is 4m/s.

Circle mode: The drone moves 10m from its current location and begins to circle with a radius of 10m with the nose always facing the origin. During circling, the right-hand joystick controls the speed and size of the orbit. Push up to increase the radius of the orbit, push down to reduce the radius of the circle (minimum radius 10m), push the joystick left to speed up the orbit or push it right to slow down the orbit. If you continue to reduce the orbit speed, the drone will change the direction of orbit and start to increase the orbit speed.

ATTI mode: This is a more advanced flight mode which does not use the GPS positioning function but still maintains altitude stabilization. The drone will drift with any wind when hovering and will not brake when the joysticks are released.

Follow Me: The remote controller has an inbuilt GPS module, and the Follow Me mode is based on the relative position of this GPS module to the drone. The maximum Follow Me speed is 10 m/s (36 KM/H).

Auto-Return: The aircraft has a one-key return function as well as an auto-return if radio contact with the remote controller is lost. When the remote control and GPS signal are good, the aircraft can be commanded to automatically return to the current remote control position.

 In the GPS mode, the drone will not arm unless there are sufficient satellites to establish the home point. This point is used if the drone cannot establish the location of the remote controller.

 In ATTI mode, the drone's top speed is faster than in GPS mode. When flying in a calm environment, the pilot should allow a minimum of 30 meters for braking distance to ensure flight safety.

 **In Follow Me mode, the joysticks are disabled. Press and hold the Follow Me button again to cancel Follow Me - the Controller Status Light will flash red confirming Follow Me mode has been cancelled and joystick function has been restored.**

When the speed of the remote controller exceeds 10m/s in Follow Me mode, the Spry will stop following the remote controller and remain hovering in place.

If the GPS module in the remote controller does not have an accurate fix the Controller Status light will flash red, Follow Me cannot be started.



Return Home

SPRY has two Return Home modes: Manual Return and Out-of-Range Return.



Manual Return: When you activate the Return Home feature of the Spry, the drone will take the last known position of the Remote Controller as the home point. If the Remote Controller has a good GPS signal, it will continue to update its position to the drone until the drone is within 10 meters of the controller's position. Then the Spry will lock the home position and execute an auto landing. (The pilot can cancel the auto landing by long-pressing the Return Home switch and then taking control of the Spry with the joysticks.)

Out-of-Range Return: If the drone loses contact with the remote control for any reason, the aircraft will execute an automatic return to the last-known position of the remote control. During the return flight, if the aircraft is reconnected to the remote control signal, the automatic return will be cancelled and the Spry will await instructions from the remote controller.

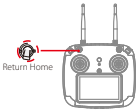
Return Home function

Remote Control Operation	Description
	<p>Press and hold the Return Home switch for 2 seconds, the system will beep and start the return process. At this point, the aircraft will auto-return to the remote controller. "RTH" is displayed in the upper right corner of the remote control screen.</p> <p>To cancel the Return Home process, press and hold the Return Home switch for 2 seconds, the system will beep and cancel the return process.</p>

Return Process

Flare Maneuver	Description
	Vertical height > 30metres and horizontal distance > 20metres, the drone will maintain its altitude and return.
	Vertical height < 30metres and horizontal distance > 20metres, the drone will ascend up to 30metres, and then return.

- ⚠ If the drone experiences a loss of GPS signal, the Return Home function is temporarily unavailable. The aircraft will hover in place until either control is restored or automatic low-battery landing takes place.
- ⚠ During automatic Return Home, when the remote control signal is restored, switch the Flight Mode briefly between GPS and ATTI mode to take control of the drone and cancel automatic return.

Drone Indication Lights

The fuselage of the drone includes a pair of Drone Nose Lights and Drone Status Lights on the rear arms. Their positions are shown below:

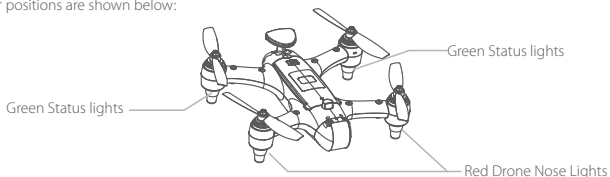

The Red Drone Nose Lights are used to indicate the direction of the nose of the drone, they will be solid red when the drone is powered on. The rear Drone Status Lights are green and indicate the status of the current flight control system. Please refer to the following table for the different flash modes for the Drone Nose and Status Lights.

Drone Nose and Status Light Messages

Aircraft initialization / horizontal calibration:



Alternating Red, Green slow flashing

Aircraft initializing / horizontal calibration

Drone power on/off



Red Fast Flashing

Remote control connected but still locked



Red ON

Remote control connected and drone unlocked

Remote controller signal



Red Slow Flashing

Remote controller signal lost

GPS Status



Green Slow Flashing

Poor GPS signal



Green ON

Good GPS signal

Compass Calibration



Green Fast Flashing

Horizontal calibration



Green Slow Flashing

Vertical calibration

Low Battery Warning



Red Fast Flashing

Low battery warning

Propellers

Spry comes standard with 6" 2-bladed propellers and is also compatible with 5" 3-bladed propellers. The 2 blade speed is relatively slow, but the flight time is longer than the 3 blade. You can choose the propellers to suit your requirements.

Installing and removing the propellers:

1. To facilitate the installation and removal of the propellers, use the included tools. (The large wrench holds the motor and the small wrench is used for the propeller lock nuts.)
2. The arrows indicates the mounting direction of the propellers. Note, that the locking nuts for each propeller are tightened in the opposite direction to the direction of the propeller.

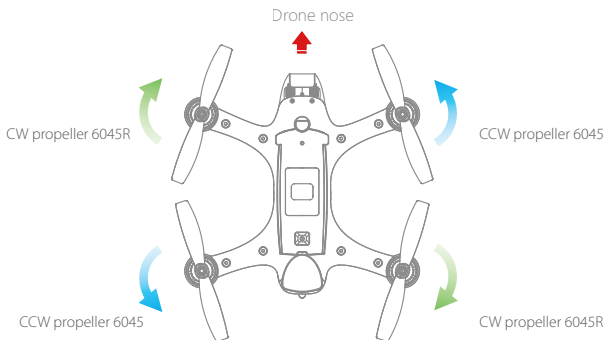

-
- ⚠ The blades are sharp. Be careful to avoid personal injury.
 - ⚠ Before each flight, check that the propellers are in good condition and securely fastened
 - ⚠ If a propeller becomes damaged, or broken, replace it before further flights. Propellers can be purchased separately.
 - ⚠ Please do not get too close to the rotating propellers and motors, to avoid cuts or injury
-

1st Micro SD Card Installation

When selecting a microSD card for use with your camera, for best results always ensure that the card is rated for 4K video throughput.

To insert the card, place the microSD card face-up in the recess inside the battery compartment. Carefully slide the card towards the nose of the Spry until it clicks and locks into place.

To remove the card, push the card gently towards the nose of the Spry until it clicks and then ejects. Take care to prevent the card from ejecting too fast out of the slot.

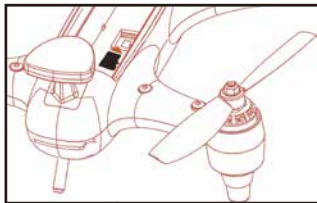

1st Battery

The Spry is supplied with a high-voltage lithium battery (LiHV) and a corresponding charger.

To charge the drone battery: Plug in the charger. After 3 seconds, its four status lights will flash left and right indicating the charger is ready. Connect the battery to the charger using the supplied adapter cable. The larger plug on the cable is inserted into the top port of the charger. The plugs are designed to prevent them being inserted incorrectly.

After the battery is connected, the four battery status indicators show the level of charge: 25%, 50%, 75%, and 100%. When all 4 lights are solid ON, the battery is fully charged.

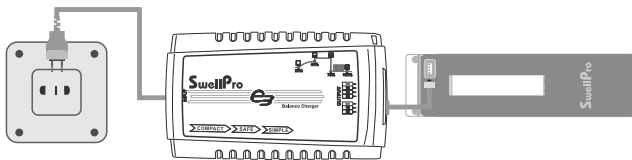

⚠ Note: If the four indicators flash at the same time, the charger or battery is faulty. Stop charging and check all connections.

Battery Installation

- Twist open the battery hatch lock. Grasp the forward end of the battery cover with the provided tool and pull the battery cover up.
- Insert the battery vertically into the drone with the contacts towards the back of the drone and press down until it is properly seated.

- c) Check that the seals on the cover are clean and lightly lubricated. Insert the back of the cover first and then press down on the cover to seal the battery compartment. Twist the battery hatch lock to secure the cover.

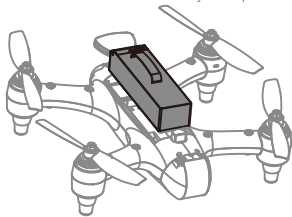

Low Battery Alarm

When the drone battery voltage drops to a low level (10.9V), the Drone Nose Lights will fast-flash red. The pilot will simultaneously receive warnings from the remote controller. The screen will display "Aircraft Low Battery" and the controller will beep and vibrate. Find a suitable place to land as soon as possible. If the aircraft voltage drops to 10.7V, the aircraft will slowly and automatically land in place.

During auto-landing, the pilot can use the remote controller to alter the landing site, but this should be done within one minute or the battery will be over-discharged and the drone may crash.

⚠ Note: During flight when the voltage warning appears on the remote controller screen, prepare to return and land the drone as soon as possible.

Low temperature precautions

1. In low temperature environments (-10C degrees to 5C degrees) , flight time will be reduced. Ensure batteries are fully charged and kept warm (20~30C) before use.
2. Also be aware that the low battery warnings will provide less warning time, so land the drone as soon as the first battery warning appears.

1st Remote Controller

This section introduces the remote controller functions, including the drone operation and the camera operation.

Charging Remote Controller Battery

The Spry remote controller has a built-in battery and charging circuit. Charge the controller using the supplied micro-USB cable and a regular 5V /2A USB charger. **Some USB ports and some USB cables cannot provide the full 2 amps (2A) of power required. These ports and cables can still be used to charge the Remote Controller but the charging time will be longer.** Normal charging time is ~90 minutes.

During charging, the remote controllers power button will glow blue. When charging is complete the blue light will turn off. Charging is possible during flight if necessary, but the remote must be connected to the drone before connecting the charging cable.

Low Battery Alarm

The remote control has a built-in lithium battery and the operating time is about 2 hours. When the remote controller battery is low, the remote control will beep and the battery power icon in the upper right corner of the screen will be red. The remote control will then have approximately 10 minutes of power left. It is best to return the drone and land as soon as possible or plug in the controller to charge the battery.

Remote Controller Operation

The Spry Remote Controller operates using two frequency bands, 2.4GHz and 5.8GHz. The 2.4GHz band is used for drone control and 5.8GHz is for the FPV video signal. The remote control has a built-in 4.3-inch FPV screen that displays real-time images and flight data of the aircraft.

Power ON and Power OFF

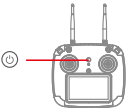
Remote Control Operation	Description
	<p>Power on: Long-press the power button for 3 seconds, the remote controller will vibrate, beep and screen will turn on.</p> <p>Power off: Long-press the power button again for 3 seconds to turn off the remote control.</p>

One Key Return Home

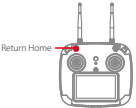
Remote Control Operation	Description
	<p>On: Long-press the Return Home switch until the the controller beeps. The aircraft enters the return state, and the FPV screen will display "RTH".</p> <p>Cancel Return Home: Long-press the Return Home switch until the controller beeps.</p>

Flight Modes

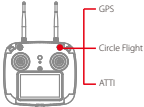
Remote Control Operation	Description
	GPS: GPS mode Circle Flight: Orbit mode ATTI: ATTI mode

- ⚠ Note: In circle mode, by activating the Follow Me mode the aircraft can fly around a moving object as long as the speed of moving objects is less than 4 m/s (15km/h).

Follow Me Mode

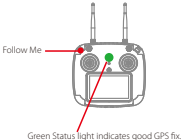
Remote Control Operation	Description
 <p>Green Status light indicates good GPS fix.</p>	When the Controller Status Light is solid green, this indicates that the GPS of the remote control has a fix and the Follow Me function is available in GPS and Circle mode To activate Follow Me , Long-press the Follow Me button "F" for 2 seconds until a beep sounds. The Controller Status Light will change to solid red, indicating that the aircraft enters the Follow Me mode. Long-press the "F" button again for 2 seconds to cancel Follow Me.

- ⚠ In the Follow Me mode, the joysticks are disabled. Long-press the "F" button again to cancel Follow Me and resume joystick operation.
- ⚠ When the speed of the remote controller exceeds 10m/s during Follow Me operation the Spry will stop following and hover in place.
- ⚠ If the remote controller's GPS does not have a fix, the Follow Me function cannot be activated.

Drone Control

Left hand throttle- (American/ European configuration)

- ⚠ Please contact us if you need to change to right hand throttle.

Left Stick

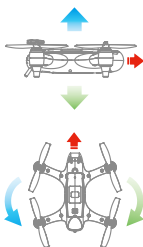

Right Stick

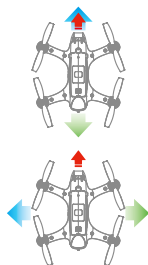

Remote Controller Pairing

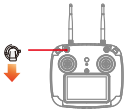
Remote Control Operation	Description
	<ol style="list-style-type: none">1. To pair the remote controller to the drone, hold the Return Home switch down and simultaneously power on the remote controller.2. The remote controller will vibrate and beep twice. The Controller Status Light will flash red and green.3. Power on the drone. After pairing has completed, the Controller Status Light will turn green.4. Long-press the FPV channel button. The FPV screen will display "RF SEARCHING" and automatically find the best FPV channel.

FPV Channel Adjust

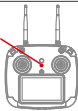
Remote Control Operation	Description
 <p>FPV Channel Button</p>	There are 8 FPV channels available. Long-press the FPV channel button (CH) and the system will automatically search for channels.

⚠ Always pair the remote controller and then select the FPV channel to match the best channels and avoid interference.



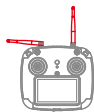

In the absence of obstacles and interference the flight height can reach >80m and FPV transmission range can reach 800m. For best reception, keep the left-hand (2.4GHz) antenna horizontal and the right-hand antenna (5.8GHz) vertical.

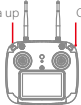

Camera Gimbal Control

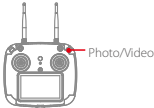
Remote Control Operation	Description
 <p>Camera up Camera down</p>	Camera up: Tilt camera up Camera down: Tilt camera down

Camera Control

Remote Control Operation	Description
	<p>Long-press the camera button (five beeps) to start or stop video recording.</p> <p>Short-press the camera button (two beeps) to take a photo. You cannot take a photo if video recording is started.</p> <p>After taking a photo, the camera information window will display a camera icon  and the resolution of the photo. The card  icon indicates the remaining number of photos the microSD card can hold.</p> <p>In video mode,  the card icon  indicates the remaining hours and minutes (hh:mm) the microSD card can hold.</p>

-  The Spry will automatically save longer video files into chapter files of 4GB. Always stop video recording before powering off the Spry or your video will be lost.

Camera

This section introduces camera parameters and use.

-  Check swellpro.com for updates to your camera's firmware.

Camera

Spry's built-in camera can capture 4K videos and 12 megapixel still images. With its inbuilt WiFi function you can also use a mobile app to change settings and download videos and photos.

Camera Settings and Use

APP installation: The SwellCam2 app is available for iOS and Android devices. Android systems can download the APK from either the Android market or our website www.swellpro.com.

To connect the app to the Spry's camera, power on the drone, then press the WiFi switch on the underside of the drone. The switch will begin flashing Red-Green. Connect your mobile device to the SwellPro... WiFi hotspot, the password is 00000000.

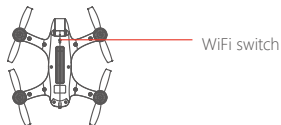

Using the APP: Open the camera APP, the screen will show the camera preview. With the APP, you can set the parameters for photos and video, you can also control the camera on the ground and take photos or videos.

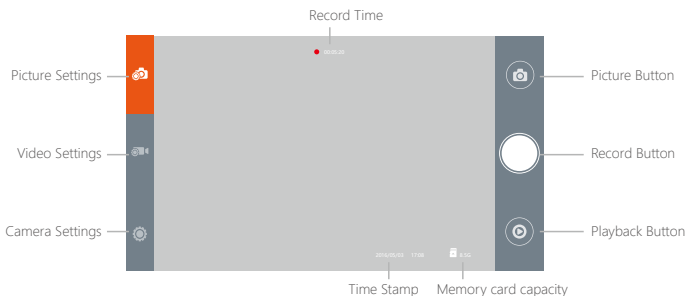

⚠ Turn off the camera's WIFI before flight by pressing the WiFi button.

⚠ When the camera is recording video, turning off the drone without first stopping the video will cause corruption of the video file. Always stop video recording before powering off the drone.

Photo Settings

Picture Size	12M 16: 9	12M 4:3
Burst Speed	OFF	3P/S 5P/S 10P/S
Interval Shooting	OFF	3s 5s 10s 30s 60s
Selfie-Timer	OFF	2s 10s

Video Settings



Resolution	3840x2160 30P	2704x1524 30P	1920x1080	120P/60P/30P	1280x720	240P
Electronic Stabilization	ON	OFF				
Record Format	MP4	MOV				
Video Format	PAL	NTSC				

 When electronic stabilization is on, distortion correction will also be turned on.

Camera Settings

EV	+2.0 +1.7 +1.3 +1.0 +0.7 +0.3 0.0 -0.3 -0.7 -1.0 -1.3 -1.7 -2.0
White Balance	AUTO, cloudy, sunny, Incandescent lamp, Fluorescent lamp
Distortion Correction	ON OFF
Metering	Global metering, Center-weighted, spot
Format	Confirm Cancel
About this device	firmware details
Restore Settings	Confirm Cancel

Camera Indicator

	Green slow flash	Camera recording
	Alternating Green-Red fast flash	WiFi ON
	Green ON	Camera in preview mode

Flight

This section describes flight considerations, flight restrictions, and drone care.

Introducing you to Flying a Drone

If this is your first time flying a drone, please read this manual thoroughly and watch the instructional videos on our YouTube channel. We recommend taking professional training and guidance. When flying, select an environment appropriate to your skills.

It is advisable for all drone pilots to become familiar with flying in ATTI mode in case of GPS or magnetic interference which can interfere with drone controls.

Flying the Spry

1. Although the Spry is waterproof, do not fly in fog or if the wind is very strong or gusting above Beaufort Force 4.
2. Select an open place or water surface as an ideal flying site.
Flying between or near large steel buildings could adversely affect the workings of the compass and can adversely affect or block GPS and control signals.
3. During flight, try to maintain line of sight with the drone, keep away from obstacles and people.
4. Do not fly near high voltage power lines or communication towers which may interfere with the remote controller of the drone.
5. When flying at altitudes above sea level, environmental factors including air density reduce the performance of aircraft and therefore also propulsion batteries.
6. When the environment temperature is below 15 C, the drone may not be unlocked. At this time, please power on the drone on the ground for about 5minutes to warm up, then it can be unlocked.

Flight Restrictions

According to provisions of the International Civil Aviation Organization and many national air traffic regulations, drones must be operated in specified airspaces.

The Spy is configured to not exceed an altitude of 200m and a distance of 800m from the remote controller.

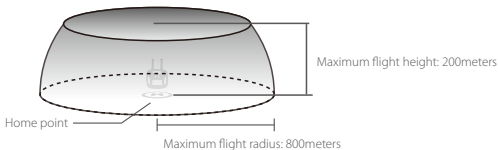

⚠ The safety fence applies in all flight modes.

1st Preparation Before your First Flight (or in a new location)

The drone relies on very sensitive sensors to control flight positioning and stability. The gyroscope and compass sensors need to be calibrated before flying in a new location or if the drone has suffered undue shock or excessive vibration.

1st Gyroscope Calibration

Gyroscope calibration is necessary if:

- The drone is brand new.
- The drone has been flown extensively in in ATTI mode.
- When in GPS flight mode and using only the THROTTLE joystick, the drone drifts at an angle.
- The drone has been subjected to heavy shaking .

Gyroscope Calibration Steps:

Remote Control Operation	Description
A top-down view of a remote controller. The left joystick is shown with a blue arrow pointing downwards. The right joystick is shown with a blue arrow pointing to the right. The center button is also indicated.	<ol style="list-style-type: none">Place the drone on a horizontal surface, power on the remote controller and the drone. Wait for the FPV interface to finish initialization.Pull the left joystick down to the lowest position and then fast flick the right joystick left and right continuously until INITIALIZING..... appears on the FPV screen.The drone will now perform calibration adjustments. Do not move or disturb the drone during this process. When the INITIALIZING message disappears from the FPV display, the process is complete.

⚠ When doing gyroscope calibration, ensure that the aircraft is placed is not subject to any vibration or movement.



1st Compass Calibration

Compass calibration is necessary if:

- The drone is brand new.
- The drone is more than 100km from the location of its last flight.
- The compass indication on the Remote Controller screen does not show the correct compass reading (North = 0°, South = 180°) $\pm 10^\circ$
- The drone has been subjected to strong magnetic fields
- The drone has been crashed or dropped accidentally
- The drone sways or drifts excessively during hover in GPS mode

Compass Calibration

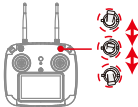
Compass Calibration is performed with the drone outdoors and away from any sources of magnetic interference such as metal structures, radio masts or mobile phones.

Remote Control Operation	Description
	1. Place the drone on a horizontal surface. Power on the remote controller and the drone. After the drone completes initialization, rapidly switch the Flight Mode switch backwards and forwards between the three modes until the drone screen displays HORIZONTAL CALIBRATION.
	2. Holding the drone horizontally , rotate the drone clockwise until the green LED lights slow flash and the remote control screen displays VERTICAL CALIBRATION.
	3. Hold the drone nose vertically downward , rotate clockwise until the screen displays "INITIALIZING" indicating the calibration is finished. Place the drone on a horizontal surface for 30 seconds, power off and restart the drone.

IMU Calibration

Calibration of the Inertia Management Unit (IMU) should only be necessary if:

- The drone has been crashed or dropped accidentally and does not fly level even after gyroscope calibration.
- The drone sways or drifts excessively during hover in GPS mode

IMU Calibration

IMU Calibration is performed with the drone on a **LEVEL, flat, stable surface**.

Remote Control Operation	Description
	<ol style="list-style-type: none">1. Push the left joystick up to the highest position and then fast flick the right joystick left and right continuously until INITIALIZING..... appears on the FPV screen.2. The drone will now perform further calibration adjustments. Do not move or disturb the drone during this process. When the INITIALIZING message disappears from the FPV display, the process is complete. Power off and restart the drone.

1st

Starting / Stopping the Motors



Precautions before unlocking the motors:

- ⚠ Place the drone in an open area at least 3 meters away from you or others.
- ⚠ When the drone is powered on, the drone will do a self-check. When it's done, there will be a "DI" sound. Keep the drone stationary during initialization.
- ⚠ If ATTI mode is selected, there is no need to wait, you can unlock the motors and proceed to takeoff and fly immediately. We recommend new pilots unlock the motors in GPS mode. The motors can't be unlocked in circle mode.
- ⚠ In GPS mode, if the number of satellites is insufficient, the remote control will vibrate when unlocking the motors, and will display "WARNING NO GPS" and the motors will not unlock.

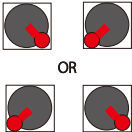
Unlocking (starting) the Motors

Remote Control Operation	Description
 <p>OR</p>	Pull both the left and right joysticks simultaneously towards either the lower inside or lower outside points. Maintain this position for 3 seconds to unlock the motors.

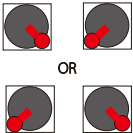
Locking (stopping) the Motors (operate cautiously)

Remote Control Operation	Description
 <p>OR</p>	<p>Pull both the left and right joysticks simultaneously towards either the lower inside or lower outside points. Maintain this position for 3 seconds to lock the motors.</p> <p>Never lock the motors in flight unless there is an emergency as the drone will crash to the ground and may injure somebody.</p>
	<p>Alternatively, once the drone has landed smoothly, pull the throttle stick to the lowest position for 5 seconds to stop the motors.</p>

- ⚠ In GPS mode, if the number of satellites is insufficient, the motors will not unlock and the FPV screen will display a warning message.
- ⚠ Motors cannot be unlocked in Circle mode.
- ⚠ The motors can be unlocked in ATTI mode even if there is no GPS fix and therefore no Home Point recorded.

Basic Flight Steps

1. Check that the drone is correctly assembled, propellers are tight and the main hatch is sealed.
2. Power on the remote control, followed by the drone.
3. Place the drone on a flat open surface or on the surface of the water.
4. Wait for the FPV screen to display the camera's live video and the OSD flight data. Check that the flight display is normal.
5. Check the following flight data: Battery voltage > 12.5volts, Satellites > 9, Compass indicates the drone's current compass direction.
6. For safety, you should stand upwind and to the side of the drone and at least 3 metres distant.
7. Arm the motors in GPS mode.
8. Push the THROTTLE joystick up slowly, allowing the drone to take off smoothly. Release the throttle when the drone is approximately 1.5m high. Allow the drone to hover for a moment to ensure flight stability. Always use gradual, smooth joystick movements.
10. When you need to descend, slowly pull down the throttle joystick allowing the drone to descend and land on a flat surface or on the water.
11. After safely landing, keep the throttle down in its lowest position for at least 5 seconds until the motors have stopped or use the disarm joystick command.
12. Stop recording video before powering off the drone, followed by its remote controller.

Water Take-offs and Landings

1. When taking off from choppy water, ascend quickly from the surface to prevent the drone being affected by a passing wave.
2. When landing on water, descend vertically to the surface. If the drone lands with horizontal speed, it is possible the drone can flip and be inverted. The flight controller will shut down the motors if the drone becomes inverted.

 **Do not leave the drone floating inverted for more than a few minutes.**
Flip the drone using the Power-Flip command or recover the drone as soon as possible to avoid water entering the drone.

Power-Flip

If the drone becomes inverted on the surface of the water, using the Power-Flip feature, the drone can be flipped so that it is right-side up.

With the drone floating upside-down, **arm (unlock)** the Spry and it will perform a powerflip and right itself on the water.

Take-offs and Landings from a Boat

When taking off from a boat there needs to be sufficient space, otherwise the drone should be placed on the water for take-off. Likewise, it is safer and easier to land the Spry on the water beside the boat rather than landing on a rocking boat or where there is insufficient space for a safe landing.

If the boat is rocking, the Spry may not arm its motors in GPS mode. In this case, carefully take-off in ATTI mode and then switch to GPS mode if there are sufficient satellites.

 For safety, it is not recommended to launch or land your Spry from your hands.

Be aware of the direction of the wind relative to the boat. Even when at anchor, it is possible that the wind will not be at the nose of the boat.

Always try and take off with the wind so that the drone will be taken away from the boat.

When landing the drone onto a boat, if possible land against the wind so that the drone will be held away from the boat.

How to Use

The Spy remote controller has a built-in Wi-Fi module that can be used to connect your mobile device and control the aircraft to perform various intelligent automatic flight modes with the Spy APP.

APP Installation: The Spy app is available for iOS and Android devices. Android systems can download the APK from either the Android market or our website www.swellpro.com.

To connect the app to the Spy's remote controller, power on the remote controller and drone, then connect your mobile device to the WiFi hotspot called SP_FF1....

After successfully connecting, open the APP to display realtime data from the drone such as voltage, coordinates, altitude, distance, GPS signal and other flight parameters.

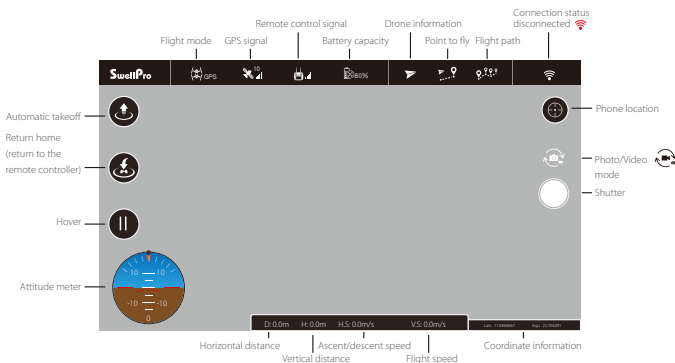

⚠ When flying indoors or in enclosed spaces, the lack of a strong GPS signal will affect the positioning stability of the aircraft. Do not use the APP to control the aircraft at this time.

⚠ If the aircraft is lost due to improper operation or malfunction, you can use the APP to locate the last coordinates to retrieve the aircraft. The Remote Control must be turned on to use the APP.

1. Once you have a minimum of 8 GPS satellites, you can unlock the drone and start flying with the remote controller or click the "takeoff" button on the APP, set the take off altitude and then slide to unlock, the drone will ascend automatically and hover.

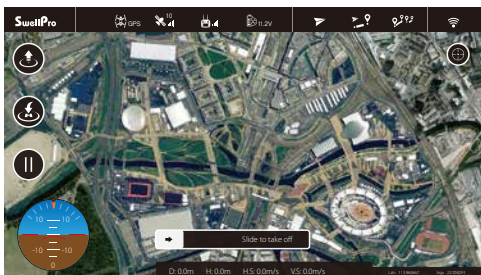
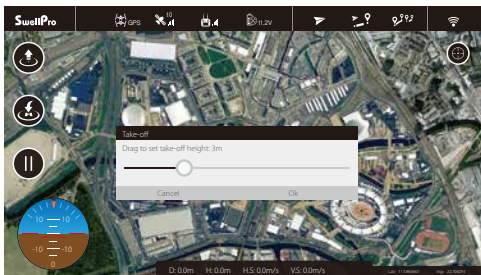

The APP allows you to set hover, return home, flight paths, follow me, tap to fly, etc.

2. Tap-to-Fly: Click the "Tap-to-Fly" button, and then click the target points on the map and click the Upload button. The drone will start flying to the point and hover there. If you need to set the parameters manually, you can tap on the flight point.



3. Flight Path Setting

- a. Tap the "Flight Path Setting" at the top of the screen and tap the map to set the flight path (double tap the flight point to delete it, tap the "Delete" button to delete all flight paths). Tap the flight point again to edit.
- b. After completing the setup, click the "Upload" button and the drone will fly according to the flight path.

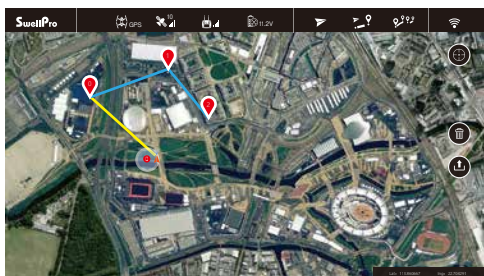

⚠ APP control requires a good wireless communication environment. If the drone does not execute the operation command, this may be due to interference, please try again.

⚠ If the drone continually fails to respond to your APP commands, please operate the drone with the remote controller: quickly switch the Flight Mode switch once, it is suggested to use the GPS mode to take over control.

Appendix

Specifications	
Drone	
Waterproof Level	Surface Buoyant
Axis Diameter	270mm
Size (Length x width x height)	233.5 x 249 x 90mm
Weight	538g (Battery excluded)
Brushless Motors	2206 1400KV
Brushless ESC	30A
Propellers	#6045
Battery	3S 3600mAh LiHV battery
Battery weight	220g
Charging Time	About 90mins
Image Transmission Channels	5.8G 8CH
Image Transmission Range	~500m
Flight Time	15-17mins
Max Flight Range	800m from remote controller
Max Flight Altitude	200m
Max Flight Speed	18m/s
Max Ascend Speed	4m/s
Max Follow Me Speed	10m/s
Positioning	GPS/GLONASS
APP Control	Automatic takeoff, automatic hover, automatic return home, point to fly, circling flight, flight path setting, camera control
Hovering Accuracy	±0.5m
Wind Resistance	>10m/s
Working temperature	-10 C -40 C

Remote Controller

Surface Buoyant	Surface Buoyant
Weight	500g (Battery included)
Frequency	2405-2475HMZ
Control Range	800m
Receiving sensitivity	(1%PER)-105dbm
Working Current	120 mA
Battery Capacity	2S 2000mAh LiPo
Charging Time	About 90mins

FPV Monitor

Frequency band	5645-5965HMZ
Image reception channels	8
Screen Size	4.3inches
Resolution	800X480Pixels
Brightness	600 cd/m

Camera

Image Sensor	1/2.3" CMOS, 12M
Lens	F4.53mm f / 2.65
Angle	92.6°
ISO Range	100-1600
Picture Resolution	12MP (16: 9)
Video Resolution	3840 * 2160 30P · 2704x1524 30P · 1920 * 1080 30P / 60P / 120P · 1280 * 720 240P
Max Video Bit Rate	64mbps
Picture Format	JPEG
Video Format	MOV MP4
Storage	Class 10 or UHS-1 and above specifications Micro SD card with max 64GB

Warranty Information

Please visit the Swellpro website to find out the latest information on:

Swellpro After-sales service policy:

Swellpro Maintenance service policy:

Note: When you receive the drone, please register your warranty on our official support page (<https://www.swellpro.com/service.html>) to register and activate the warranty (This is very important; it will ensure your drone is covered by the after-sales terms in the warranty period).

**Warning:**

Please read the ENTIRE user manual to familiarize yourself with the features of this product before use. Failure to use this product in a safe and responsible manner could result in fire, serious injury or damage to the product, or other property, please observe the following safety guidelines when using, charging, or storing the batteries.

1. Battery Use

- Do not allow the batteries to come into contact with any kind of liquid.
- Do not drop the battery into water.
- Do not leave batteries out in the rain, or near a source of moisture. If the inside of the battery comes into contact with water, chemical decomposition may occur, potentially resulting the battery catching on fire, and may even lead to an explosion.
- Never use non-Swellpro batteries. New batteries can be purchased by going to www.swellpro.com, or through your local Swellpro dealer. Swellpro takes no responsibility for any damage or injury caused by using non-SwellPro batteries.
- Never use or charge swollen, leaky or damaged batteries. If your batteries are abnormal, please contact Swellpro, or a Swellpro authorized dealer for further assistance.
- The battery can be used in the temperatures ranging from -10°C to 40°C. Use of the battery in environments above 50°C can lead to a fire or explosion. Use of the battery below 10°C can lead to permanent damage.
- Never disassemble, or penetrate the batteries with sharp tools, otherwise, this may result in the battery catching fire, or even lead to an explosion.
- Electrolytes in the battery are highly corrosive. If any electrolytes make contact with your skin or eyes, immediately wash the affected area with fresh running water for at least 15 minutes, and then see a doctor immediately.
- If the battery falls into water, pick it up immediately and put it in a safe and open area. Maintain a safe distance from the battery until it is completely dry. Never use the battery again, and dispose of the battery properly as described in the Battery Disposal section below.
- Do not heat batteries. A battery fire can be extinguished using sand, or a dry powder fire extinguisher.
- Do not put batteries in a microwave oven, or in a pressurized container.
- Do not put the loose battery cells onto any conductive surface, such as a metal table.

- Do not put any conductive cables or metal objects together with batteries, where they may short-circuit against each other.
- Do not drop or strike batteries.
- Do not place heavy objects on the batteries or the battery charger.
- Clean battery terminals with a clean, dry cloth. Failure to do so may result in poor electrical contact, which could reduce the battery capacity, or damage the charger.
- Do not continue to fly the drone after the low battery alarm has been activated; this will result in over-discharging the battery, and potentially could damage the battery cells.



DO NOT continue to fly the drone after the low battery alarm has been activated, this will result in over-discharging the battery, and potentially could damage the battery cells.

2. Battery Charging

Attention:

- Always use a Swellpro approved charger to charge the battery of the drone, and the radio controller. Swellpro takes no responsibility if the battery is charged using a non-Swellpro charger.
- In order to avoid any potential accidents happening, please do not leave the battery charging unattended.
- Do not charge the battery near flammable materials, or on flammable surfaces, such as carpet or wood.
- Do not charge battery immediately after flight, because the battery temperature may be too high.
- Disconnect the charger when not in use. Examine and maintain the charger regularly.
- Do not clean the charger with denatured alcohol or other flammable solvents.
- Never use a damaged charger.

3. Battery Storage and Transportation

- Keep batteries out of the reach of children and pets.
- Do not leave the battery near heat sources, such as a furnace, heater, or exposure to strong direct sunshine, for example: in cars.
- The ideal storage temperature is 22°C ~ 28°C.
- Keep the battery in a dry and ventilated environment
- Never drop the battery into water, or store it in places where there is a possibility of water leakage.
- Do not drop, strike, impale, pierce, or manually short-circuit the battery.
- Keep the battery away from metal objects, such as watches, jewelry, and hairpins.
- Never transport a damaged battery, or a battery with power level higher than 50%.
- Do discharge the power to 50% or less before transportation.(The suggested battery voltage level of the drone is around 12.1V, and the radio controller is 50%)
- Do discharge the power to 50% or less when you are not going to use the drone in the coming days.

4. Battery Maintenance

- Never use the battery when the temperature is too high or too low.
- Never store the battery in environments with a temperature higher than 60°C .
- Do discharge the power to 50% or less when you are not going to use the drone in the coming days.
- Never store the battery for a long time after use. If need to store for long time, need to fully charge the battery and then discharge to less than 50% every one month. Otherwise the battery will become over-discharged, and ruin the battery.
- Never over dis-charge the battery, otherwise the battery cells will be damaged.
- Do not charge battery immediately after flight, because the battery temperature may be too high.

5. Battery Disposal

- Dispose of the battery in specific recycling boxes only after a complete discharge.
- DO NOT place the battery in regular trash containers. Strictly follow your local regulations regarding the disposal and recycling of batteries.

1. Flying Conditions and Environmental Considerations

- Fly in open spaces or above the water surface that is far away from crowds.
- The operating temperature range of the Spry is -10°C to 40°C.
- Observe local regulations and flight restrictions of your Aviation Authority.

2. Pre-Flight Inspection and Checks

- Make sure all batteries are fully charged.
- Check all propellers are in good condition and correctly fastened. The edges of the propeller blades must be smooth and undamaged.
- Manually rotate the 4 motors to ensure they can spin smoothly.
- Ensure the sealing surfaces of the cover are clean, free of dirt, sand, or any other contaminants.
- Make sure the drone fuselage is sealed and that the membrane on the top of the battery cover hatch is in good condition.

3. Flying Guide

- Many regulations require the pilot to fly a drone within line of sight. Take particular care when flying a drone out of sight.
- Unless it is an emergency, NEVER Lock or STOP the motors in flight as this will cause the drone to fall to the ground and crash.
- When the low battery level warning is activated, plan to return the drone and land safely before the battery reaches a critical level.
- The Return Home function can be used to reorient the drone towards the Home Point. By activating the Return Home function, the drone will rise to the the return altitude (20m) and then turn towards the Home Point before starting its return.
- If any obstacles are in the flight path of the drone during a Return Home process, control should be regained by turning off the Return Home function.
- If you inadvertently crash your drone, lock the motors to prevent damage to the motors and propellers.

- Do not attempt to touch the motors, until the motors have stopped rotating.
- When taking-off & landing from water, avoid high-speed or abusive landings to avoid damaging the drone.
- When flying over water, avoid allowing the drone to drop or crash into the water from a high altitude as this could cause major damage to the drone.
- Don't expose the drone & battery to direct sunlight for sustained periods of time as this can raise the internal temperature of the drone to well above the operating temperature range.
- If the drone does not appear to be responding to the Remote Controller as usual, switch the Drone to ATTI flight mode and fly the drone to a safe landing location.

The possible causes for the instability or loss of control of the drone could be:

- The drone has been subjected to unstable GPS signal/s or spurious interference/effects on the Compass module during flight.
- The calibration of the drone (compass and/gyroscope) was incorrectly carried out.

Steps that can be taken to resolve the issues:

- Re-calibrate both the compass and gyroscope on the Spry.
- After completing the calibration, arm the drone motors to fly in GPS mode to verify whether this phenomenon has been eliminated.
- If the abnormality remains the same, please re-locate to another place at least 5KM away and re-calibrate the Spry. Following the re-calibration, please test the drone again.
- If the problem persists, please contact SwellPro or your local dealer for further trouble-shooting and solutions.

4. Maintenance

- Please make sure to double check the propellers after flight. Distorted or damaged propellers should be replaced immediately.
- **After flying over the sea, sand or water, the Spry drone and remote controller must be thoroughly washed with fresh water within 2 hours and dried - especially the motors.**
- **It's strongly advised to rinse the drone before the salt crystalizes.**
- **Motors are best rinsed by removing the propellers and immersing the motors one at a time into a bucket of warm water and arming the drone so the motors spin.**
- In the event of the Spry not being used for a long time, please store the drone and the batteries in a dry, and ventilated environment at 20°C~28°C.
- Please refer to <Safety guideline with batteries> for further details on maintaining the batteries.

5. Flight Safety

- Please make sure you have a comprehensive understanding of the Spry and all the necessary measures required to implement a successful return home function in the event of an emergency.
- Please be well prepared before each flight, avoid any violent or excessive operations.
- Please maintain strict compliance with the local laws, any flying in NO-FLY ZONEs is prohibited.
- Any illegal & improper use or operation of this product is prohibited.
- Any invasion & violation against another person/s right of privacy is not allowed. Before using this product, it remains the duty of the drone pilot to comply with the local laws regarding privacy protection.
- Any invasion or flying over another person/s property is not allowed, please agree with any person/s regarding any potential breach of privacy before the proposed flight.
- Avoid flights in or around the strong magnetic fields. This includes wireless electricity emission towers, high-voltage transmission lines, transformer substations, radar towers and other magnetic sources or metal objects.
- DO NOT fly the Spry under the influence of alcohol, drugs or any other physical or mental impediment.
- Please don't fly the drone with a malfunctioning radio controller - Please fly the drone away from crowds.

Restricted Area



Airport



Crowds

Threats to Flight Safety Scenarios



Radio signal tower



Radar



High voltage power lines



Trees



Tall buildings



This product is not a toy, and should only be operated by persons over the age of 15. Please keep it out of reach of children, and pay particular attention to the possible scenarios of children's unexpected appearance during flight operation.

Be sure to read this document carefully before using the product, to fully understand your legal rights, responsibilities and safety instructions. Failure to do so, may cause property damage, safety accidents and personal safety risks. Once this product is used, it is deemed that you have understood, recognized and have accepted all the terms and conditions of this statement. The user is responsible for all the consequences of his actions and consequences. The user agrees to use the product for his sole & legal purpose, and agrees with the terms & conditions of this agreement, and other relevant policies & guidelines that may be specified by SwellPro.

Under the maximum permission by law and approved circumstances, SwellPro is exempt of liability for any indirect, punitive, consequential, special or criminal damages, including the purchase cost, or for loss of income due to the loss of use of the drone.

SwellPro is exempt from the user's liabilities for damage(s) to person/s or property, or injuries incurred directly or indirectly from the use of this product in the following conditions:

- Damage or injuries incurred when the user/s are under the influence of alcohol, drugs or medication.
- Any malfunction caused by operators' failure to follow the guidance of the manual to assemble and set up or operate the drone as described and designed.
- Damage or injuries that may occur due to failure to study the tutorial videos and the user manual before flying the drone.
- Damage or injuries caused to a person/s or property due to failure in correctly calibrating the drone as outlined in the manual prior to flight.
- Damage or injuries incurred as a result of the use or installation of any unauthorized third party accessories or counterfeit parts - which were not provided and approved of by SwellPro.
- Damage or injuries as a result of flying the drone out of eyesight range, or more than 300m away from the controller.

- Damage or injuries caused by flying the drone in areas of magnetic fields & radio interference.
- Damage or injuries caused by flying in a NO-FLY ZONE that is regulated by local laws & rules.
- Damage or injuries including crashes, loss of control or water ingress caused by abusing or modifying the original drone structure,
- Damage or injuries caused by using broken & ageing components.
- Damage or injuries caused by continuing to fly the drone even if the low battery alarm is activated.
- Damage or injuries caused by failure to wash the components with fresh water after flying over or near the sea & corrosive waters.
- Damage or injuries that have occurred when the drone has been subjected to the following conditions or situations: collision, fire, explosion, floods, tsunamis, ice, snow, avalanche, flooding, landslide, earthquake, etc.
- Damage or injuries incurred by intentionally dropping or crashing the Spry into the water from a high altitude, especially water ingress into the drone fuselage.
- Damage or injuries incurred by intentionally dropping or crashing the Spry to the ground or water from a high altitude, especially water leakage into the drone fuselage as a result of this collision.
- Other Damage(s) or injuries that are not SwellPro's liability.

Version Information

SwellPro products are constantly being improved. Therefore, although the latest version of this manual may contain information relating to a release of the equipment different from your own, new information is added constantly which is relevant to ALL customers.

Version	Comments
1.0	Pre-release Manual for Spry
2.0	New Manual for Spry
2.4	Updated details of USB charging and Gyroscope Calibration
2.6	Added IMU Calibration and Page Reflow, Camera control
2.8	Added Low Temperature Flight Warning
2.9	Added APP Control Warning
2.91	Added use the APP to locate the last coordinates to retrieve the aircraft
2.92	Added SPRY Camera Firmware Update Instruction
2.93	Updated Return Home
3.0	Consolidate changes - various clarifications
3.1	Updated FLIGHT BATTERY -Safety Guideline
3.2	Updated Return Home

