



CHASING

M2 Pro Max Training

CHASING INNOVATION TECH CO., LTD

www.chasing.com



CONTENTS

01 / Product Structure

02 / How to Use

03 / Other Aspects

04 / Maintenance & Caution

05 / Hands-on Activity

01

Product Structure



01 Product Structure

01

ROV Structure

1. Camera
2. Thruster/Propeller
3. 2*4000LM LED Lights
4. Micro SD Slot
5. Main Cabin
6. Battery Cabin
7. Buckle Bracket
8. LED Light Adjustment Knob
9. Hand Grip(Up&Down)
10. Peripheral Interface
(Ethernet port: 1, 2)

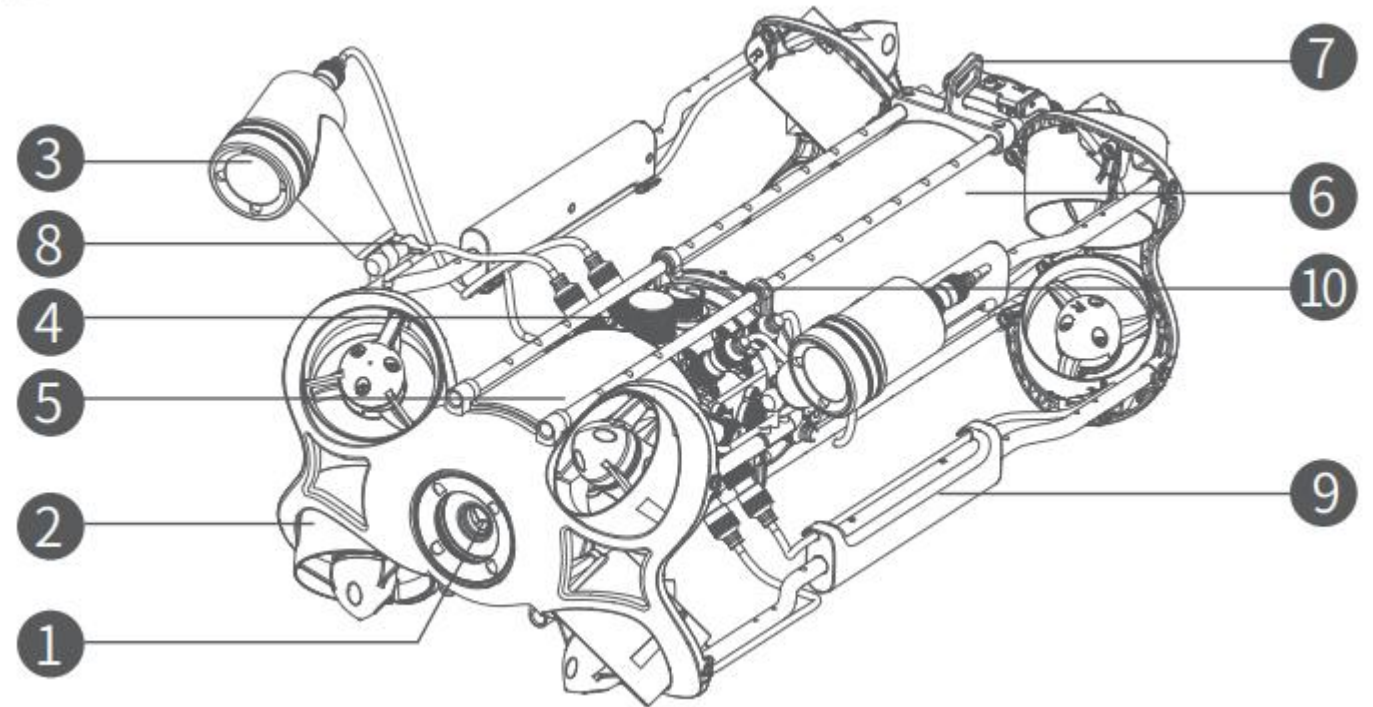

01 Product Structure

01 ROV Structure

- 11. Peripheral Interface
(Serial Port: UART1, 2, 3)
- 12. Battery Twist lock Knob
- 13. Depth&Temperature Sensor
- 14. Battery Pull Ring (For battery disassembling)
- 15. Tether Socket/Charging Socket (The pins are prohibited to exposure in seawater/salt water)
- 16. Battery Fastener

NOTE:

- ① UART1/2: 3V3TTL;+15V,30W
- ② UART3: 3V3TTL;+18V~+25.2V,50W
- ③ Ethernet1/2: 10/100Mbps,+16V,40W

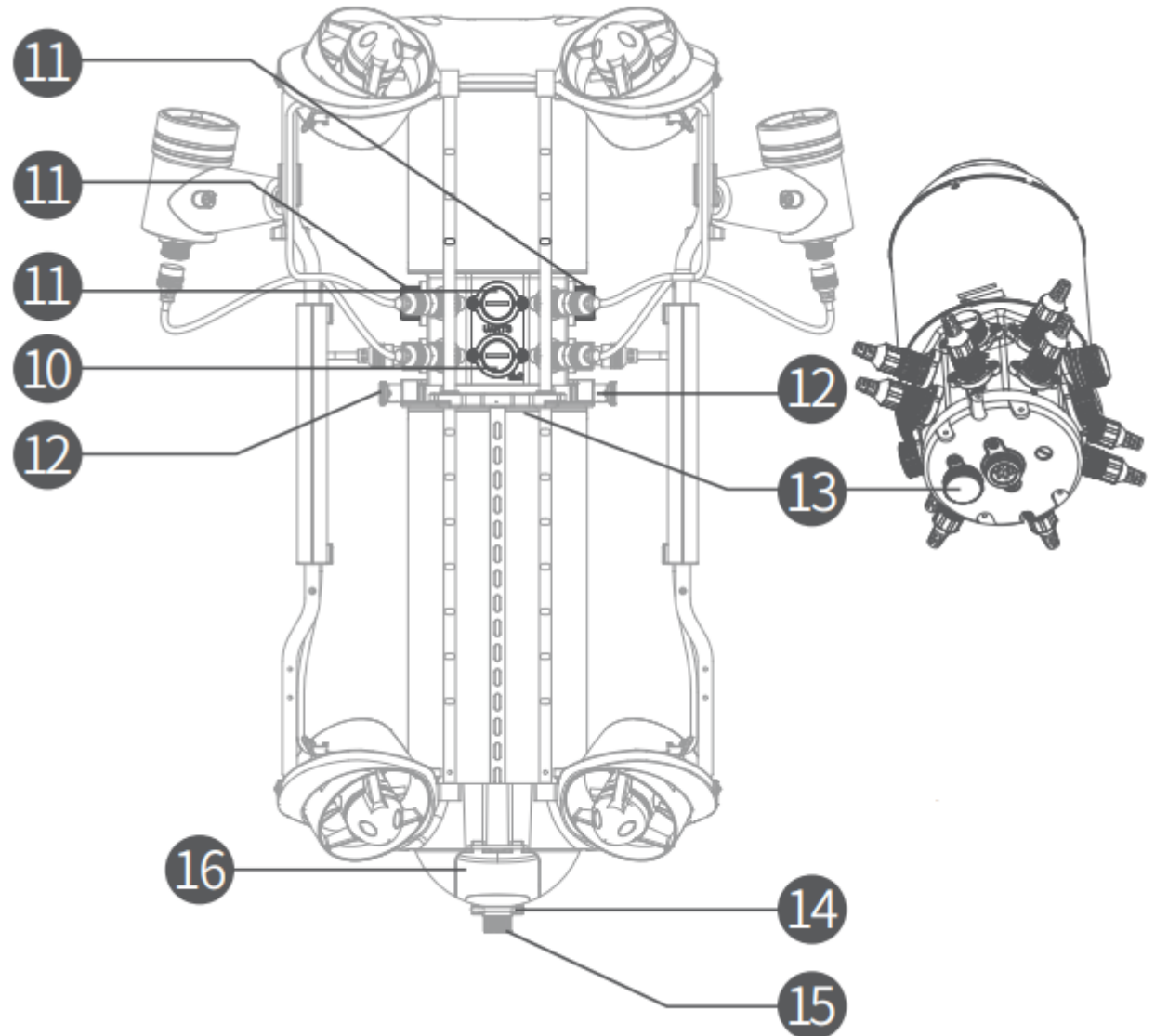

01 Product Structure

02 Remote Controller

1-3. Signal Indicator: ROV/2.4G/5G

- ROV: Indicates the communication status between the controller and the drone (Steady light indicates successful connection; Blinking light indicates disconnection.)
- 2.4G: Wi-Fi indicator, always on when working
- 5G: Wi-Fi indicator, always on when working

4. Wi-Fi switch button: Short press to switch 5Ghz/2.4Ghz Wi-Fi

5. Power switch: Turns controller on/off (Unlocking: Blue light on)

6. Power Indicator: Green (High power), Blue (Medium power), Red (Low power)

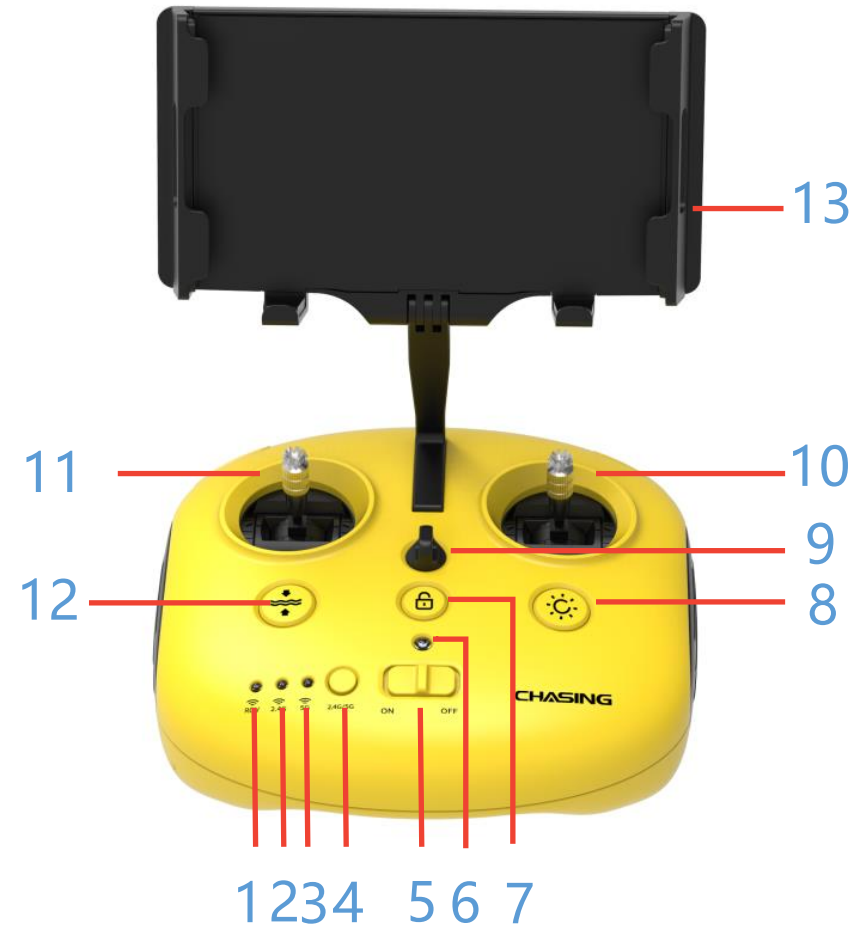

01 Product Structure

02 Remote Controller

7. Unlock: Unlock/Lock, current state of the Thruster will show on the App
8. Led Control: On/Off led light (0%, 1-99%, 100%)
9. Safety Buckle: Can be used with a safety rope to prevent dropping
10. Right Control Stick: Used to control the navigation of the ROV
11. Left Control Stick: Used to control the navigation of the ROV
12. One-key reset: Short press to reposition the ROV return to a horizontal state/
Long press to switch control mode The blue light is always on when the ROV is in a non-horizontal position.
13. Phone/Tablet Clamp: Used to attach phone/tablet to mounting bracket, supports mobile devices up to 10.5 inches (pull the ends apart to put the device in, press the button on the back to tighten the device)

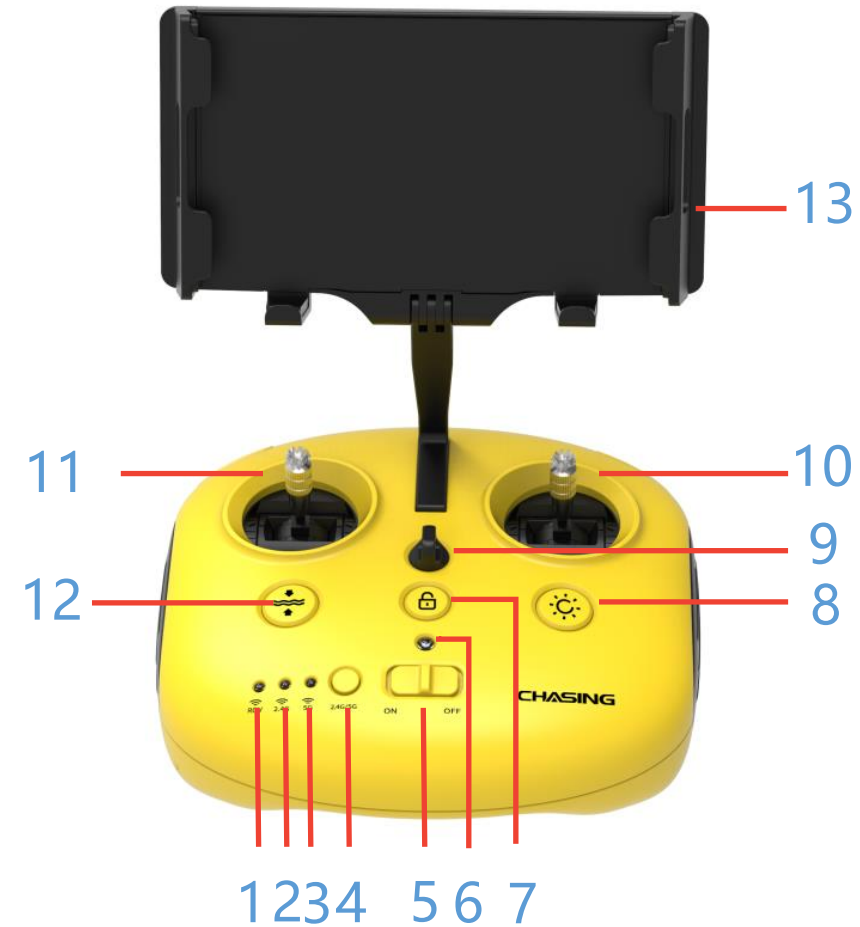

01 Product Structure

02 Remote Controller

- 14. Robotic Arm Control: long press to enable/disable the grabber claw function; short press to switch the floodlight brightness level
- 15. Right Wheel: Adjust the roll angle or control the opening and closing of the grabber claw
- 16. Photo/Video: Short press to take photos, long press to start / end recording video
- 17. Left Wheel: Adjust the pitch angle
- 18. Type-c Port: Wired connection with mobile phone/tablet device
- 19. HDMI Socket: 1080P HD image real-time output
- 20. Tether Connection Socket/Charging socket

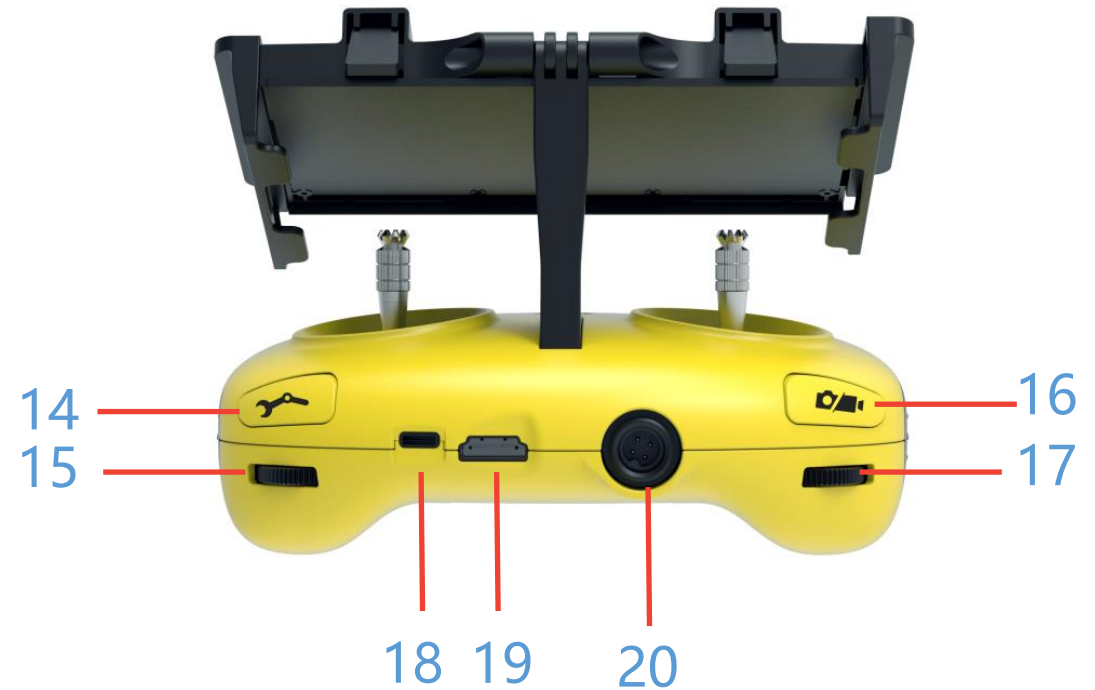

01 Product Structure

03 E-reel

1. Power switch
2. 3 Meters Tether/ Charging socket
3. Speed knob: stop/slow/fast
4. Power indicator: Green 100%-60%;
Blue 59%-20%; Red 19%-0%
The indicator flashes when the motor is running
5. Handle interface
6. Handle: Used for manual winding
7. Straightener

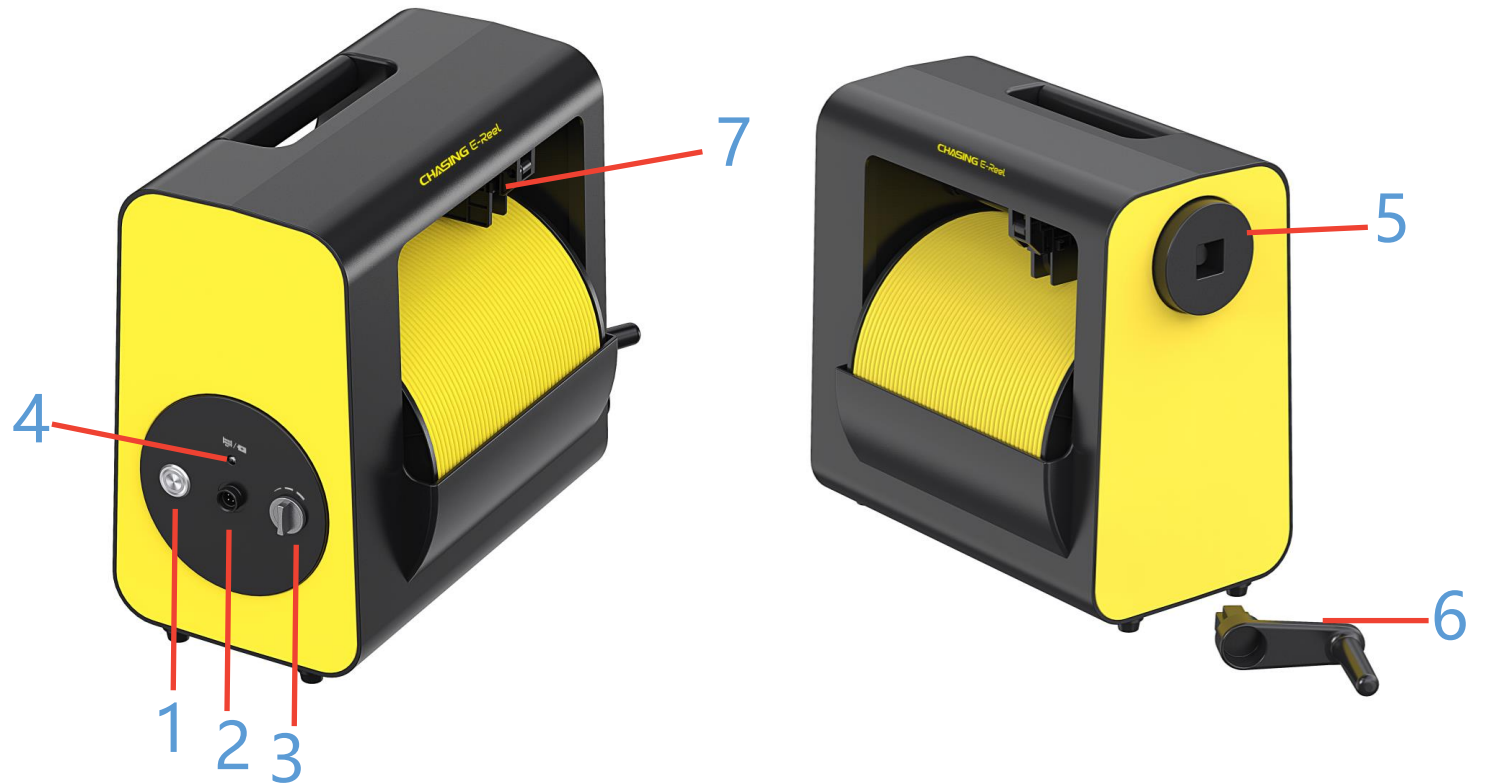

01 Product Structure

03 E-reel

- Support IP65 waterproof and dustproof level.
- Support up to 200 meters of tether cable.
- Built-in 4800mAh high-capacity battery. The frequency of power discharge is up to 30 times in a full power state. It can be manually retracted via the rocker if no power.

NOTE:

- ① Put the power on, please wait 4 seconds after rotating the speed knob to the certain gear for the first time.
- ② Do not put the E-Reel in the water or splash liquid on it.



02

How to Use



» 1. Download CHASING GO1 App

CHASING GO1 App:

(For iOS 9.0/Android 4.4 and above)

- Android devices: Use your mobile browser to scan the QR code on the right to download or download from Google Play/CHASING official website.
- iOS devices: Search CHASING GO1 in the App Store



2. Unfold the Floodlights

- ① Turn the knob counterclockwise to unfold the floodlights.
- ② Turn the knob clockwise to tighten the floodlights for use.

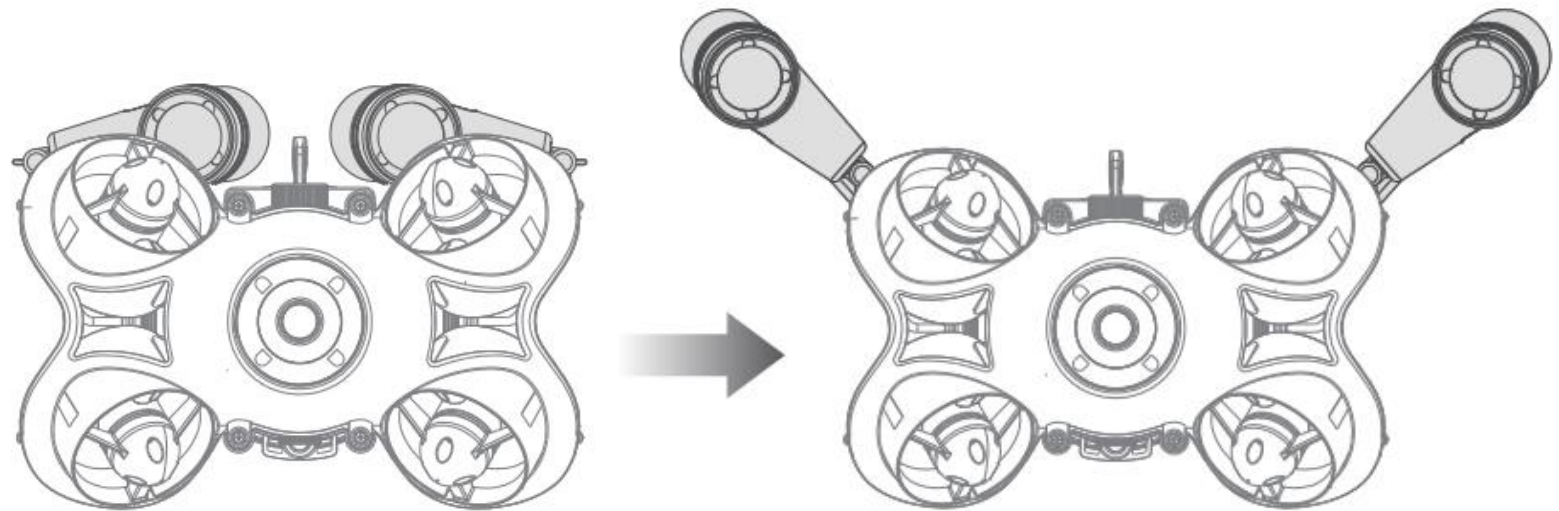

Fold up to storage

Unfold to use

2. Unfold the Floodlights

③ Application: The floodlights can be disassembled and installed on both sides under the ROV, which can adapt to various complex applications underwater.

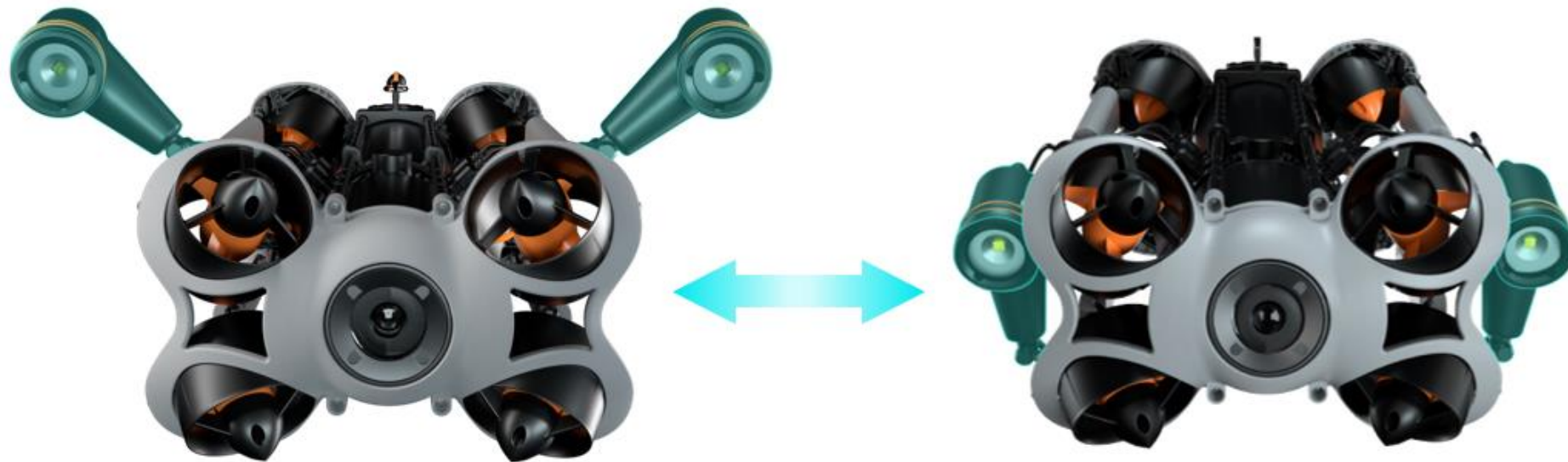

3. Installation & Connection

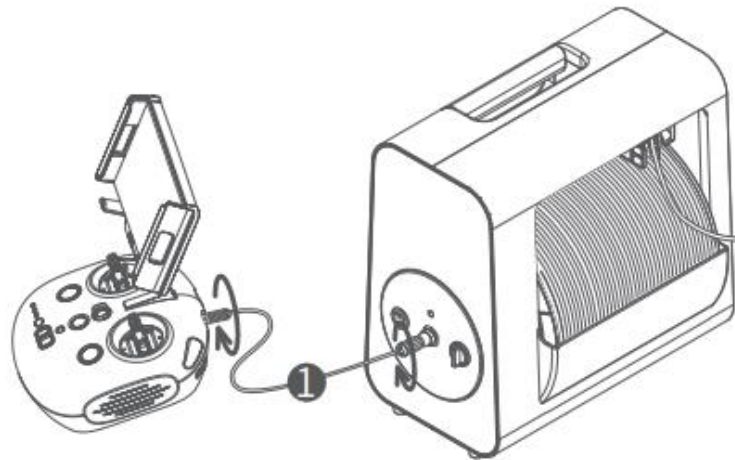

1. Connect the E-reel to Controller with the 3 meters tether cable and tighten the nut ①

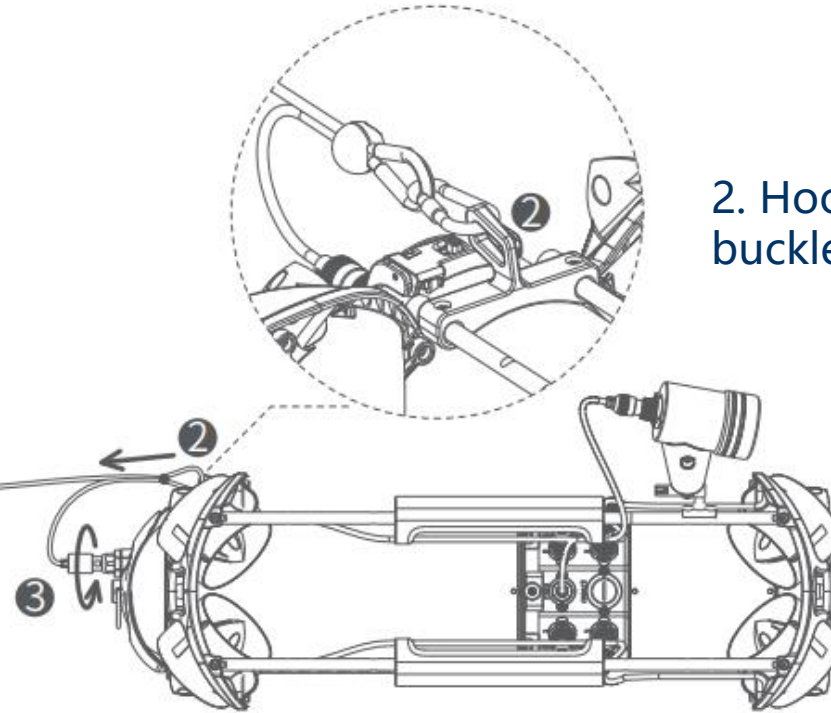

2. Hook up the tether cable buckle to position ②

3. Connect the tether connector to the ROV position ③ and tighten the nut

3. Installation & Connection



That's all set!

» 4. Power on

Turn on the remote controller power button. A few seconds later, the remote controller's indicator lights up, and the 5G or 2.4G light will be always on. Also, the ROV makes two self-test sounds.



5. Connect the controller with the APP

• WIFI Connection

1. Please find the SN on the bottom of the remote controller;
2. Go to the Wi-Fi setting on your phone/tablet;
3. Wait for 5-10 seconds and the Chasing_ xxxx (SN last 6 numbers) network will appear on the WiFi connection list;
4. Click to connect and input the Wi-Fi Password: 12345678



» 5. Connect the controller with the APP

- **USB Direct Cable Connection**

Connect the controller to the mobile phone/tablet with the included adapter cable (You may select the corresponding adapter cable according to the mobile device's interface.)

PS: connect the end with the printed phone pattern to the phone/tablet.

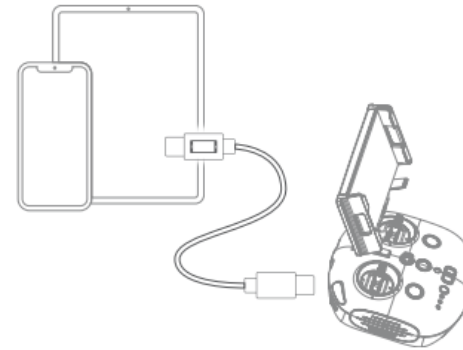

APP Interface Introduction

- Open the APP and enter the camera, you could see the real-time scene transmission view of camera.

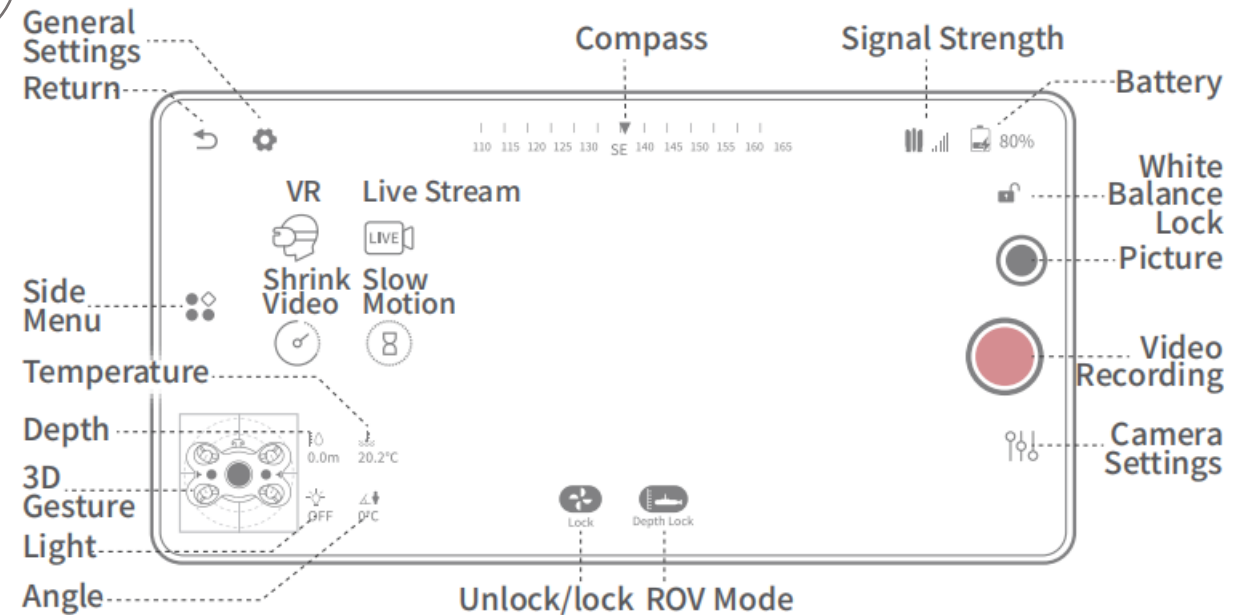

» 6. Use Underwater

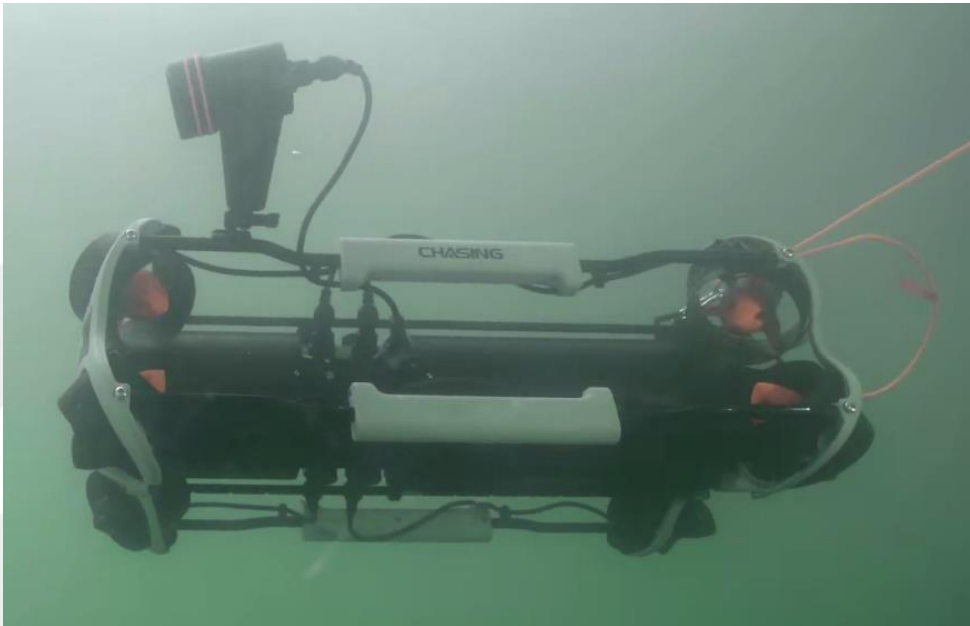

- Grasp the grips on both sides of the ROV and gently throw the ROV into the water. Unlock the thruster(motors) to dive.
- For a better experience, it is recommended to use it where the water depth exceeds 1 meter.

03

Other Aspects



1. E-reel Usage

① Wind Down

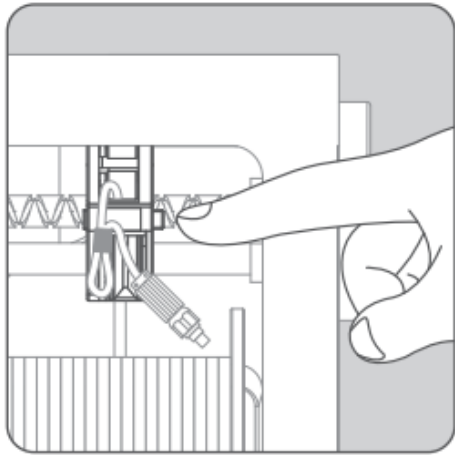

Press the button on the right side of the straightener to open the lid.

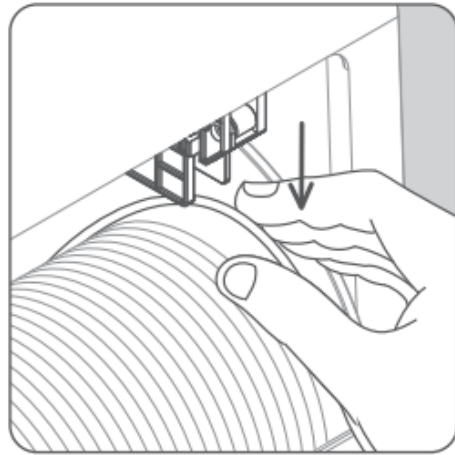

Take out the tether from the straightener.

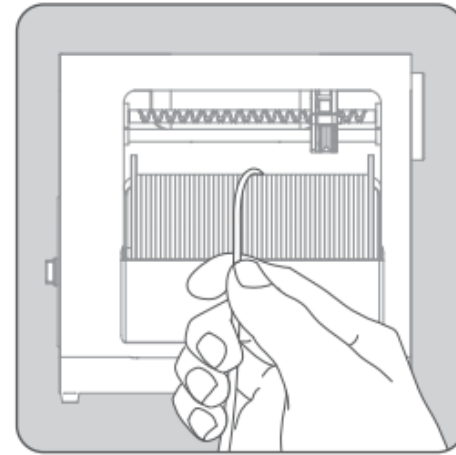

Close the lid, Start to wind down the tether by hand.

03 Other Aspects

1. E-reel Usage

② Wind Up

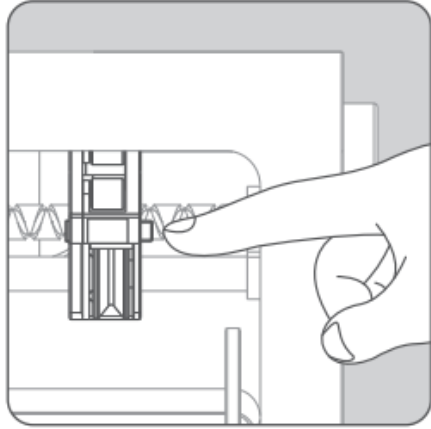

Press the button on the right side of the straightener to open the lid.

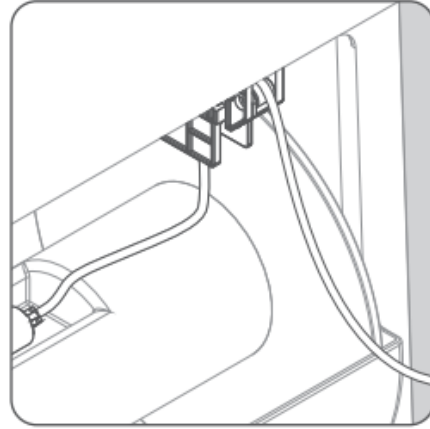

Install the tether into the straightener, as shown in the picture. Close the lid of the straightener.

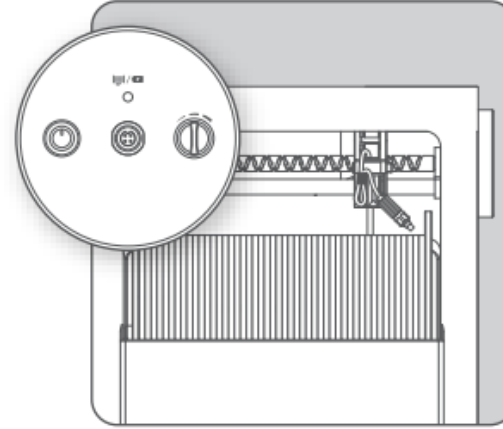

turn on the switch, rotate the speed switch to slow/fast speed and start winding.

2. Video and Photo Download

① Method 1: Download to Phone/Tablet

1. Open CHASING GO1 App, click the Media button in the lower right corner.

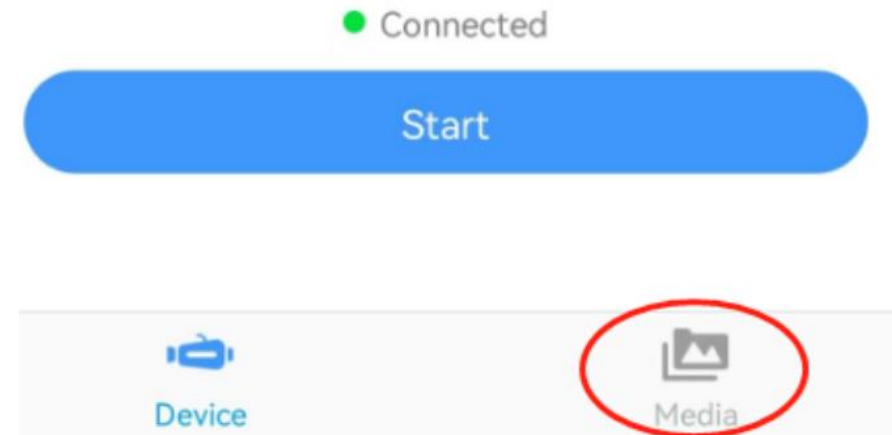

» 2.Video and Photo Download

2. Find the video/photo that you want to download. Click the download button and the image will be saved directly to the phone/tablet's photo album.

Android: save to the download folder

iPhone: save to the album

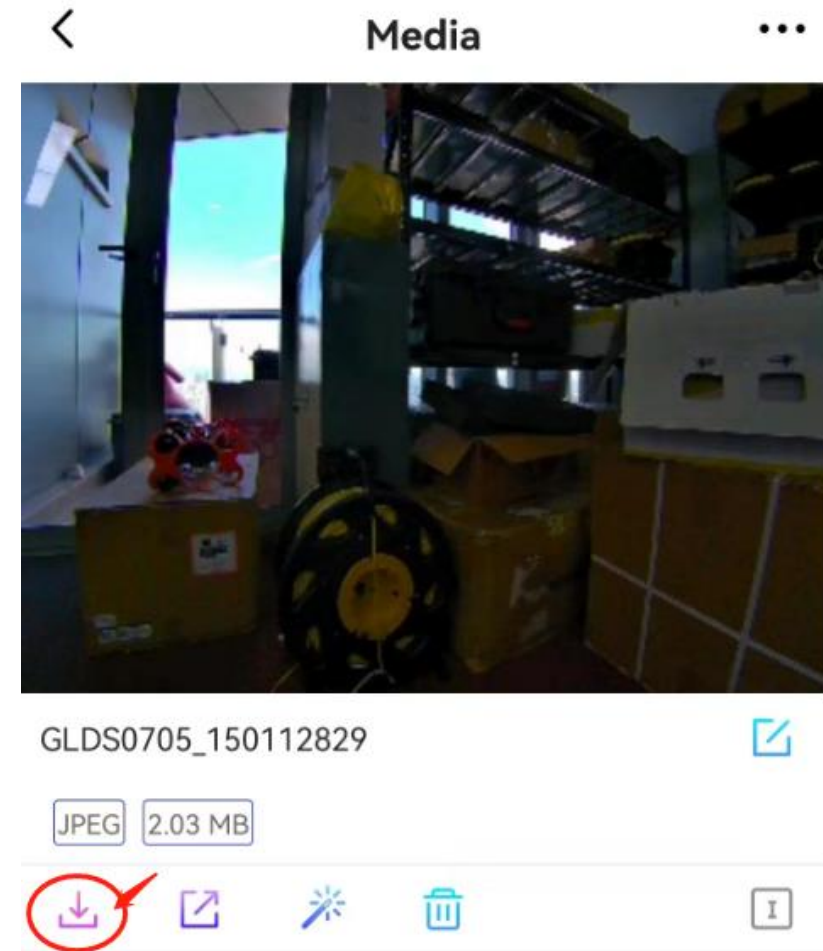

2.Video and Photo Download

②Method 2: Micro SD card copy

1. Turn off the Remote Controller and dry the ROV, especially the SD card socket.
2. Unscrew the Micro SD card socket cover counterclockwise and remove the Micro SD card.
3. Read the SD card in a Card reader, and copy the images with computer

※NOTE: Before removing/inserting the Micro SD card, please make sure the ROV is powered off and stays dry.



2.Video and Photo Download

③Method 3: Download to Computer

1. PC connects to the remote controller's WiFi.
2. Open the web browser and type IP address:192.168.1.88
3. Find the video/photo that you want to download. Click the download icon and save, then the images will generally save in the Download folder.
4. It is recommended to use Firefox or Google Chrome browser for a better experience.

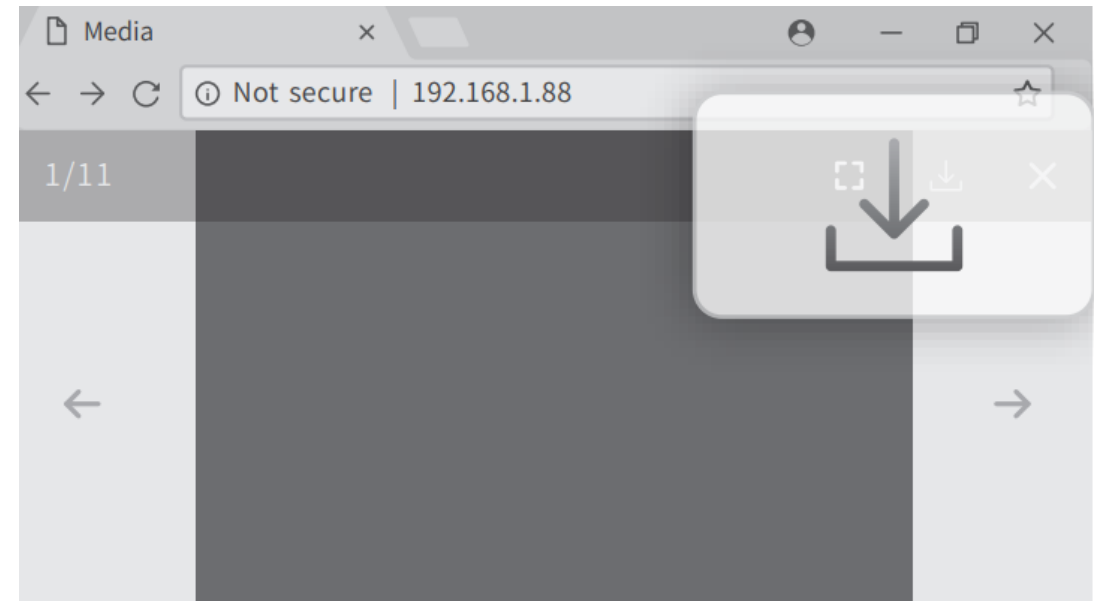

3. Disassemble and Install the Battery Cabin

① Disassemble

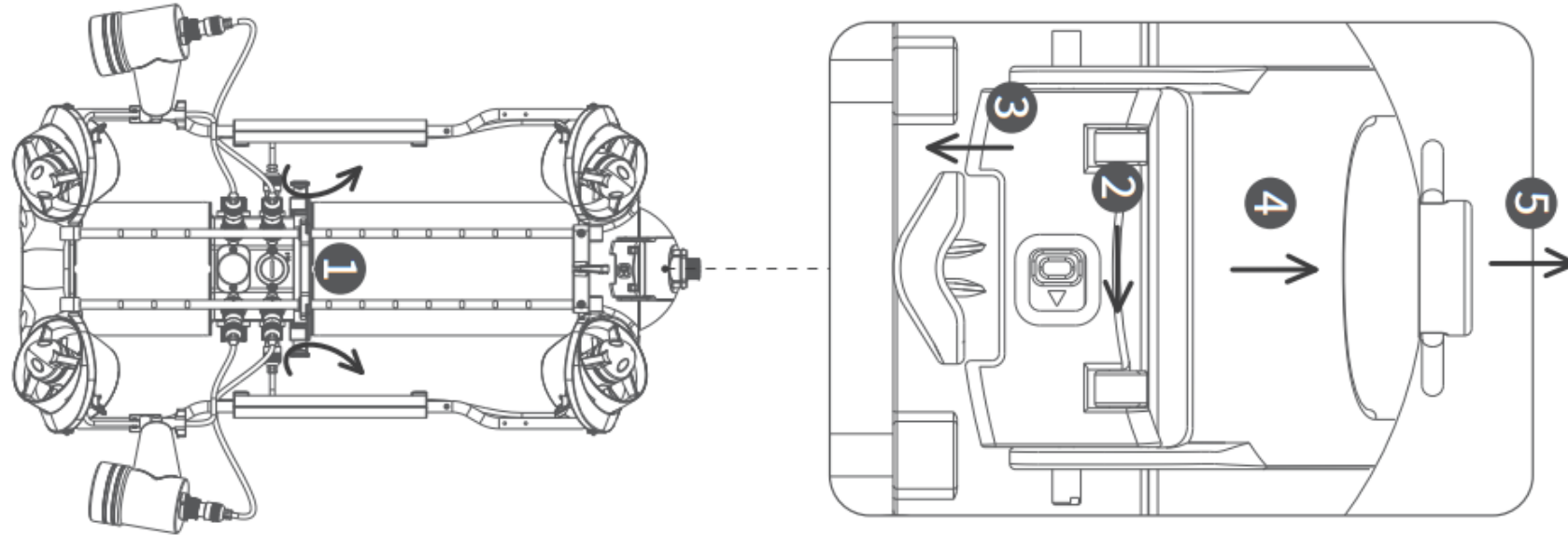

1. Unlock the knobs on both sides of the fuselage and rotate them to 90° to the shallow slot ①;
2. Pull the switch ② on the slider and toggle the lock assembly upwards while holding the chute ③ ;
3. Pull the lower sides of the Pressure Plat④ and pull down to deform the Pressure Plate ④ , and make the buckle come off the rear bracket;
4. Pull the battery ring-pull ⑤ to take out the battery cabin slowly.

3. Disassemble and Install the Battery Cabin

② Install

1. Rotate the knobs on the both sides of the fuselage 90 ° to the deep slot;
2. Slowly install the battery cabin along the chute under the fuselage. Press down hard until you hear a "click" sound, and the knobs close in place;
3. Pull the lower sides of the Pressure Plate by hand, pull down to deform the Pressure Plate ③, make the buckle fasten on the rear bracket;
4. Press down firmly on the chute of the locking assembly. When you hear a "click" sound, the buckle is snapped into place properly, then the installation is complete.

4. Thruster Shield Installation

① Install the thruster shield

- ◆ The three snap structures on the thruster shield should correspond to the thruster conduit bracket structure one by one, then press down the shield with slight force, and when the sound of clatter is heard, the shield is assembled in place.

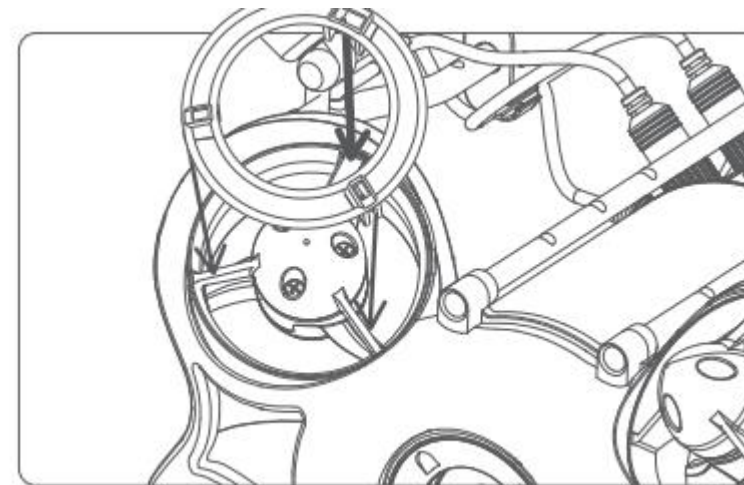

» 4. Thruster Shield Installation

② Disassemble the thruster shield

- ◆ Use the screwdriver(or other tools) to gently pry the shield along the edge of the shield clasp position, so that the shield clasp one by one from the conduit bracket, and finally remove the thruster shield

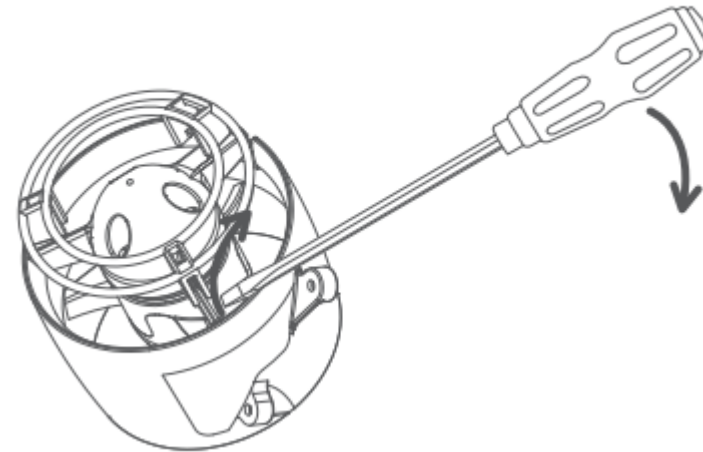

» 5. Charging

① ROV & Remote Controller

Charger Spec: **25.2V 8A**

- Red light indicates Charging, green light indicates fully charged.
- After fully charged, please disconnect the charger in time.
 - ROV charging time: 2.5H
 - Remote controller charging time: 2H

NOTE: Charging time varies depending on environmental factors (e.g. temperature).

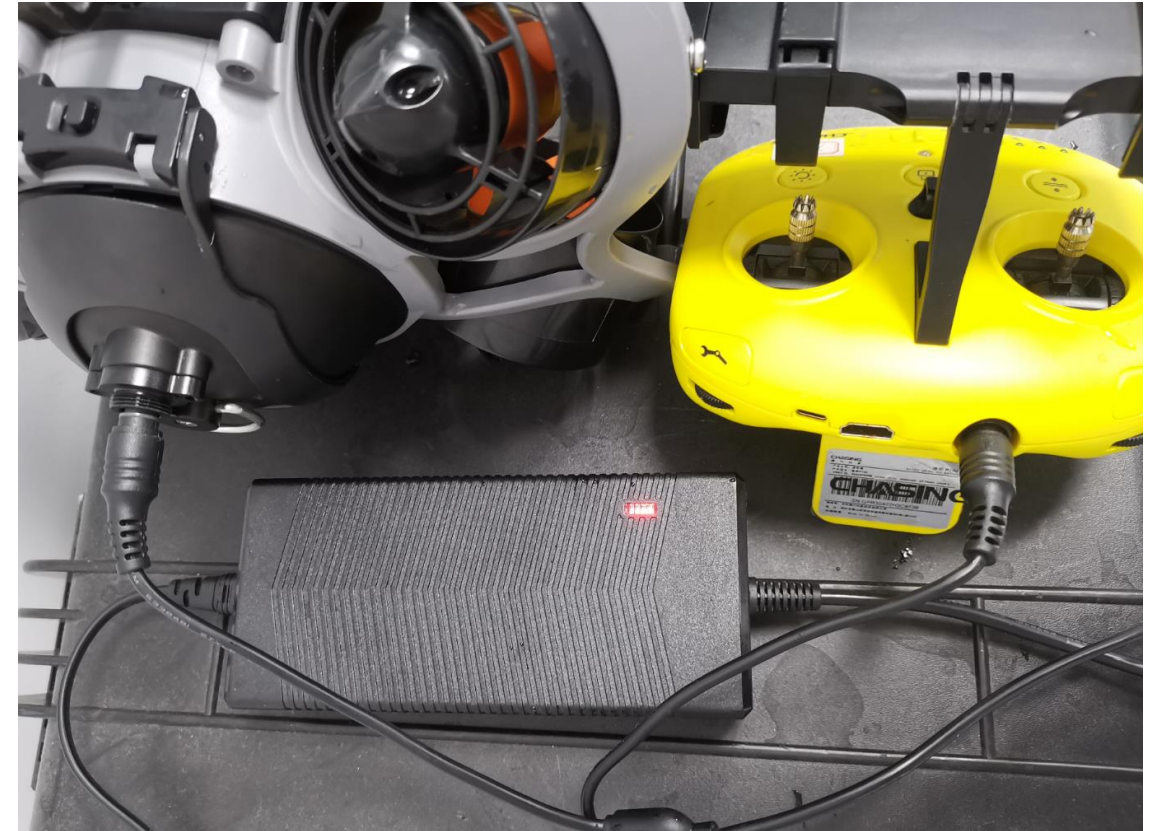

» 5. Charging

② E-reel

Charger Spec: **25.2V 8A/12.6V 3A**

- Red light indicates Charging, green light indicates fully charged.
- After fully charged, please disconnect the charger in time.
- Charging time: 2H (12.6V)
4H (25.2V)

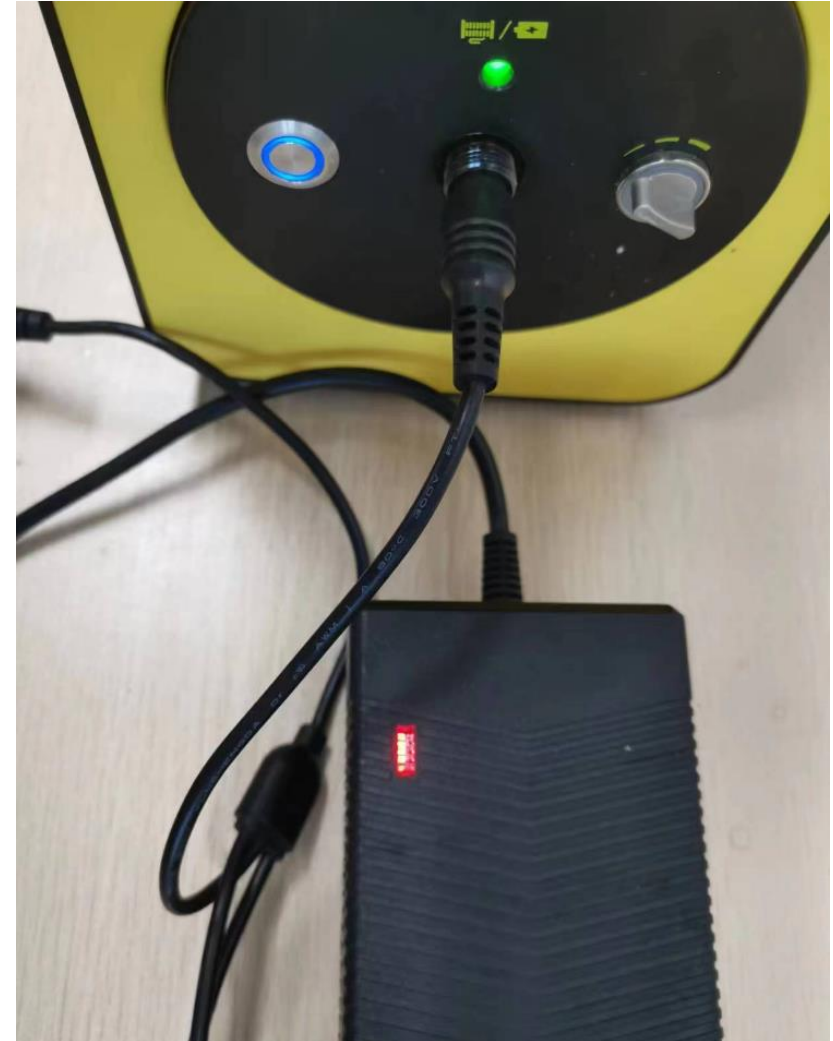

04

Maintenance & Caution





1. Navigation Safety

- Recommended to navigate in open sea.
- Recommended to use in relatively clear water without dense algae.
- For the first time, it is recommended that users practice in the open sea to familiar with the basic operation of the machine.
- Pay attention to the location of the tether cable during daily operations, away from boat propellers, passing boats on the water and underwater obstacles such as ropes and rocks to avoid entanglement causing the loss of the machine.

2. Battery Security

1. ROV battery is under a power-off mode when in transportation. Please charge it to activate the battery for the first use.
2. Try to avoid running out of the ROV power, please charge it when below 25%.
3. If the battery is left idle for a long time, please charge the ROV regularly every 2-3 months to keep the battery power at 50%-70%.
4. If the ROV is idle for a long time(Not Charged), when it needs to use, we recommend to let the ROV discharged till completely dead and leave it alone for 1 hour. After that, keep it charged for at least 12 hours. That is, let the battery do a deep charge/discharge learning.
5. Use the Chasing standard adapter only.



3. Motor Maintenance

1. Do not touch the rotating propellers
2. Do not unlock the thrusters for more than 30 seconds in the air to avoid overheating
3. When the propellers wear out seriously, there may be a decline in machine power. It is recommended to replace the new propellers; please contact Chasing after-sales for guidance to replace the propellers.
4. After using the ROV in the salt water, please put it in fresh water for about 1 hour and turn it on, let the drone run for 10 minutes to discharge the salt, and dry out the water after cleaning with a towel.

✘ It is recommended to use the machine maintenance function (CHASING GO1 App: Click the upper right corner → Help-Machine maintenance-ROV-To maintain)



Machine maintenance

Rov

Battery

Maintain the underwater vehicle

1. Connect the underwater vehicle
2. After connection, put the underwater vehicle into fresh water, which can be a bathtub/basin, to ensure that the submersible is completely immersed in the container, as shown in the figure below

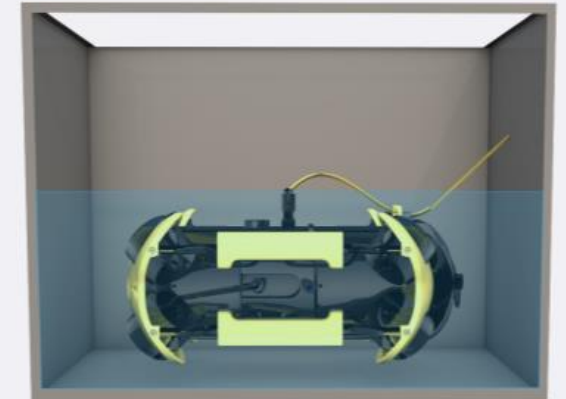

3. Click the 'Start maintenance' button, the machine will start the motor cleaning after restart, and will stop at its own will after completion. Please wait patiently
4. Please clean the motor in time after each use in salty water or fresh water with more sediment, which can extend the life of the submersible

To maintain



4. Other advices

1. Check the cover of the peripheral interface and Micro SD card interface is securely in place before use. Check whether the O-ring on the tether connector/battery socket/SD card socket pre-dive, and make a replacement when it is missed or damaged.
2. Check the Connector socket and tether pre-dive, keep dry and clean. Salt and moisture may cause corrosion of the connector. Be sure to wash the socket with fresh water if the interface has water stains, and make the connectors dry after cleaning.
3. When not in use, please do not expose the drone and accessories to sunlight. Store it in a cool place or in a special box. The remote control is not waterproof. Please avoid being water splashed. It cannot be washed with water, please clean it with a towel.