



# Combi - Tank<sup>TM</sup>

Combined Buffer and DHW Cylinder

## Installer Guide

### Suitable for Heat Pump Hot water and Heating

Features as standard

**Buffer coil for Pre heating of DHW via Higher COP extraction or secondary input to heating.**

**Dedicated Hot water reticulation connection.**

**Optional Solar PV inputs for both DHW and heating.**

**DHW Temperature gauge.**

Energy efficient heating solutions : Designed and developed for New Zealand homes, by Heat IQ



Energy efficient Air to Water home heating systems,  
developed by **Heat IQ** for New Zealand homes.



## Save more energy

Developed right here in New Zealand by Heat IQ Combi-tank® is designed to compliment our Eco+Logic Inverter heat pumps. However it's unique flexibility and energy saving features are fully compatible with almost any brand of Air to water heat pump.

## Key features

Energy saving pre heater coil for DHW Utilizes High COP energy to DHW	✓
High performance Large surface area coil for HP HW heating	✓
PV Solar ready DC element port in DHW Cylinder for PV to DHW input	✓
PV solar ready DC element port in Buffer tank for PV to heating input	✓
230V element port in optimized HP controlled position	✓
Reticulated DHW return connection point	✓
System pressure vessel anchor Tab for on case mounting	✓
Space Saving Design Buffer and Cylinder in a 550mm diameter single shell	✓
Duplex Stainless Steel with additional Anode protection in DHW Cylinder	✓
Tight space installation with all connections XX° accessible.	✓
Wipe Clean color steel shell with feet	✓

DETAILS ON THE FOLLOWING PAGES ASSUME USE WITH Eco+Logic HEAT PUMP

## System buffering

In the base is a buffer tank providing Hydraulic separation between the heat pump and the attached heating system. Providing controlled and consistent Flow rates across the Heat pump for peak efficiency, the buffer also stabilizes demand, minimizing potential for short cycling of the HP compressor, to further enhance efficiency. The buffer is sized to ensure there is sufficient volume of water for a short and energy efficient defrost cycle.

*(Defrost is part a HPs normal operating process, miss managed it can be energy inefficient ).*

## Pre heated domestic hot Water

Within the buffer tank is a coil specially designed to provide pre heating of the domestic hot water cylinder input. This pre heating coil utilizes heat energy from the Higher COP, low temperature HP input to the buffer tank body water. Contributing to the hot water heating system the pre heater reduces the cost of heating domestic hot water when the heating system is operational by up to 15% compared to a conventional HP to direct diversion to DHW cylinder coil system where heat input is at a lower COP.

## Taking in the sun

Combi-Tank® is configured to allow both the heating and Hot water system to benefit from Solar PV (power) input. Dedicated PV element ports are provided in both the DHW cylinder and the buffer tank for Solar DC input

## Fully managed hot water

Used with an Eco+Logic HP's integrated hot water management system to achieve the best possible combined heat and hot water performance. The Eco+Logic system gives you complete control over DHW production including reticulation if required.

## Smart and safe

Unlike some other HP systems Eco+Logic HPs fully manage Legionella protection of DHW with controlled, efficient and Safe dedicated scheduled programming.

DHW CYLINDER		BUFFER TANK	
Construction	Duplex SS	Construction	Duplex SS
Capacity	245L	Capacity	70L
Input Coil DHW	22mm OD 24M	Pre Heating coil*	22mm OD 6m
Hot & Cold ports	3/4" BSP Female	Coil connections	3/4" BSP male
Reticulation Return,	1/2" BSP Female	Buffer ports	1" BSP Female
TPR port	1/2" BSP Female	Element Port PV	1 1/4" BSP X1
Element Ports DC PV	1 1/4" BSP X1	Insulation	50mm PU
Element Port 230v,	1 1/4" BSP X1	Probe pockets	X 1
Probe pockets	X 2	Anode	N/A
Anode	Included	Sludge Drain	Included
Insulation	50mm PU in Shell	Insulation	50mm PU in Shell
Overall outer case dimensions . 2080 mm x 570 Diameter . Including feet			
Pre heat coil may alternatively used as an input source			

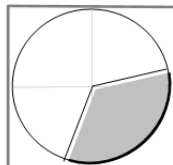

Pipe and element connections fall within a Radius allowing installation in tight cupboards and corners

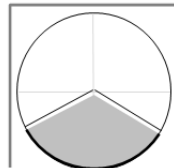

Min 650

## Dimensions

Dimensions may vary slightly due o manufacturing process

Duplex Stainless Inner

White colour-steel outer

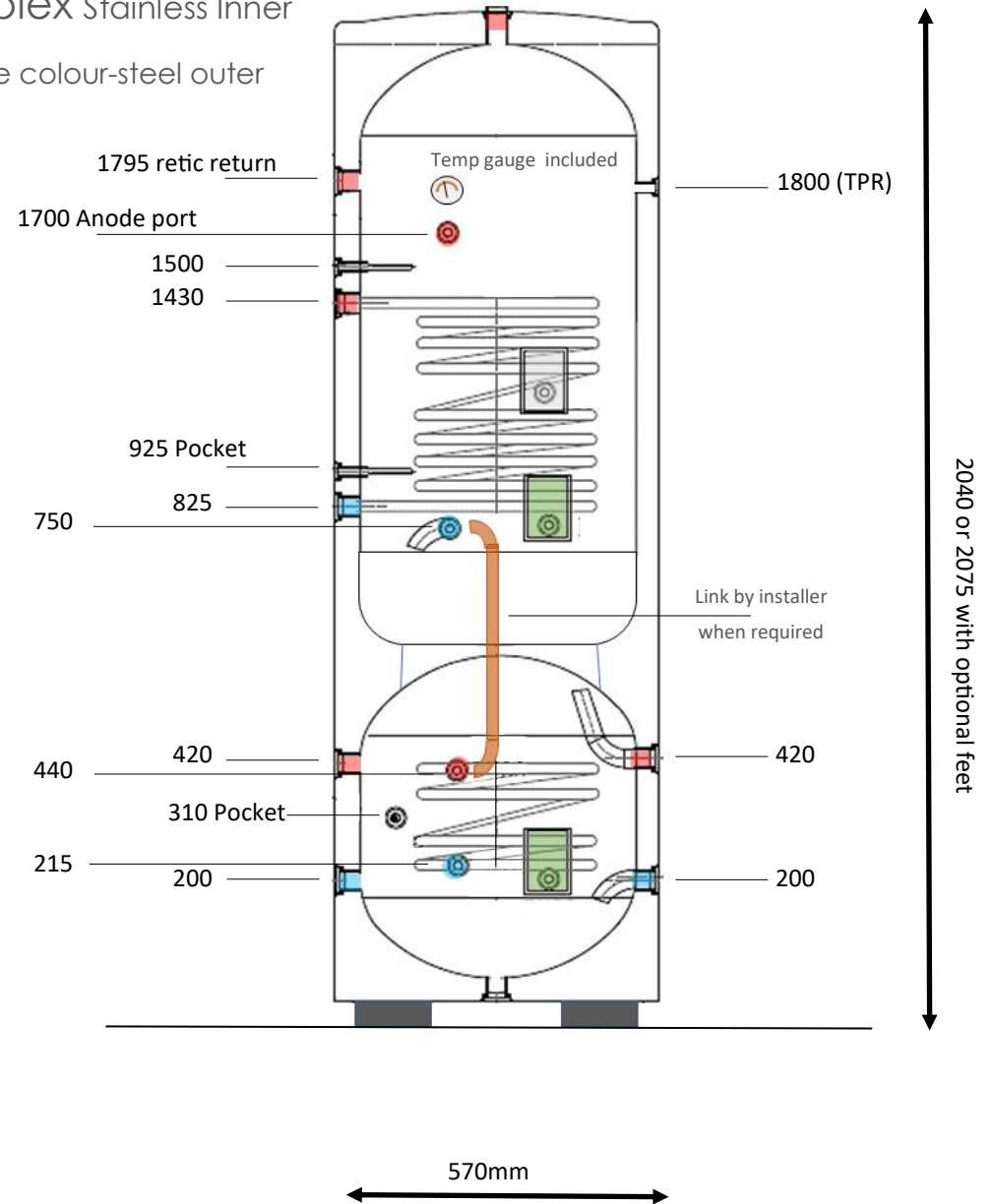

Mechanical connections : Heating & Hot water systems

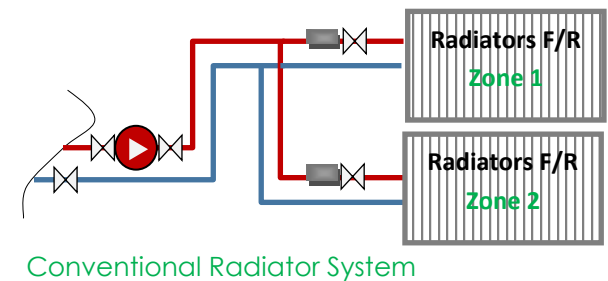
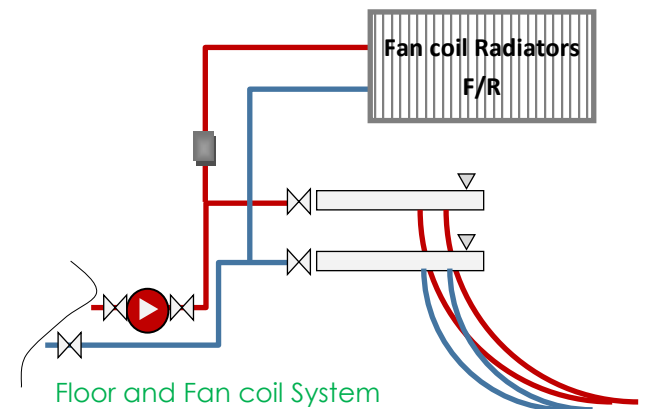
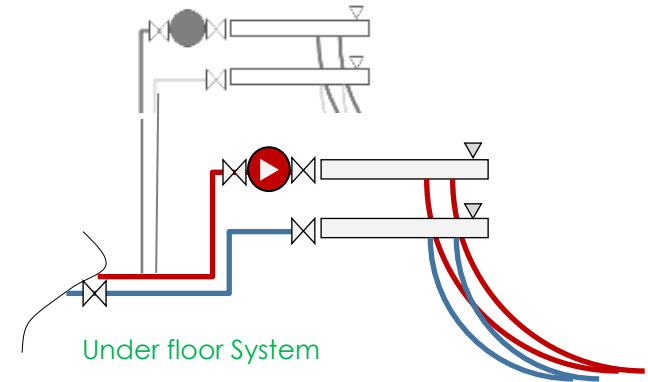
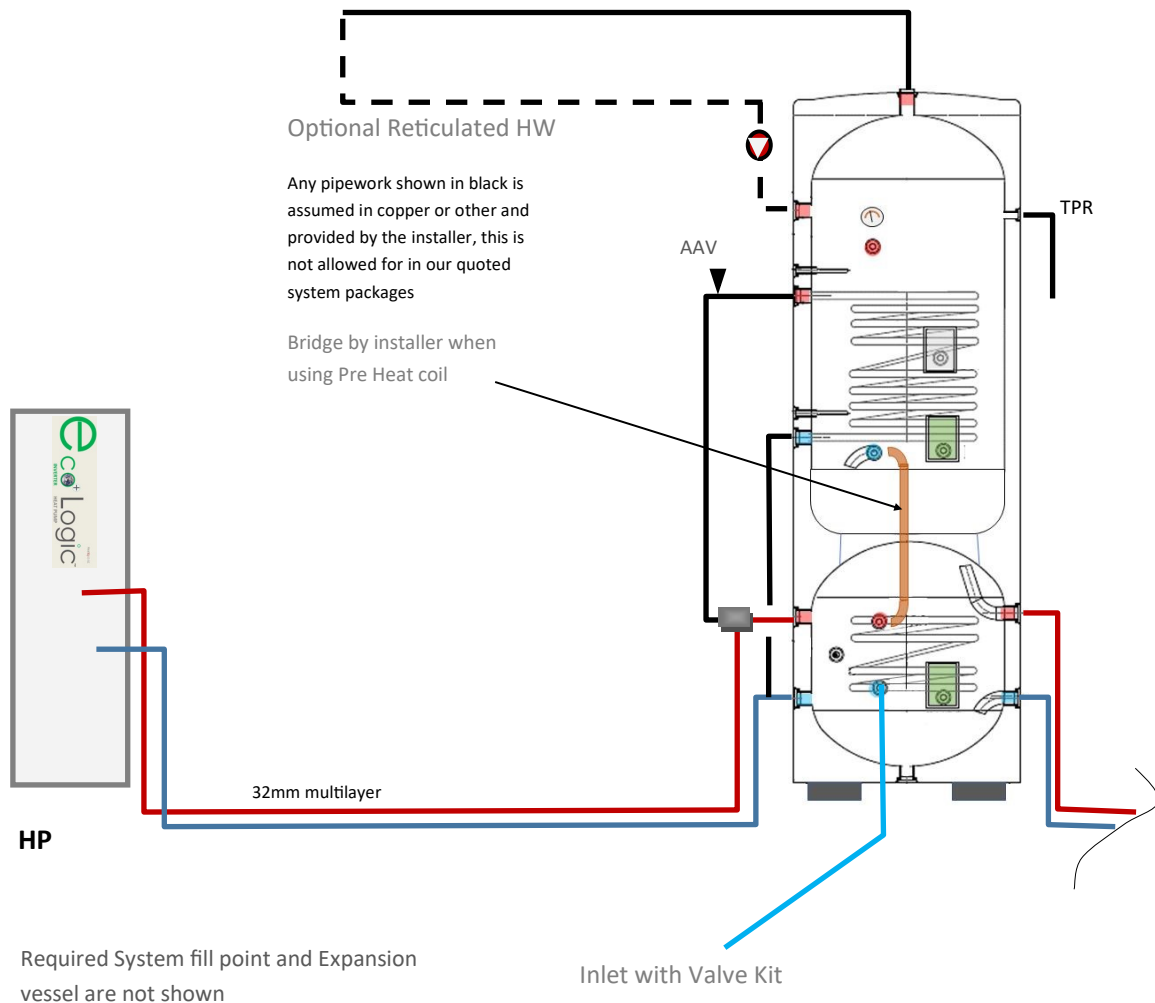

## Mechanical connections : Systems with Cooling

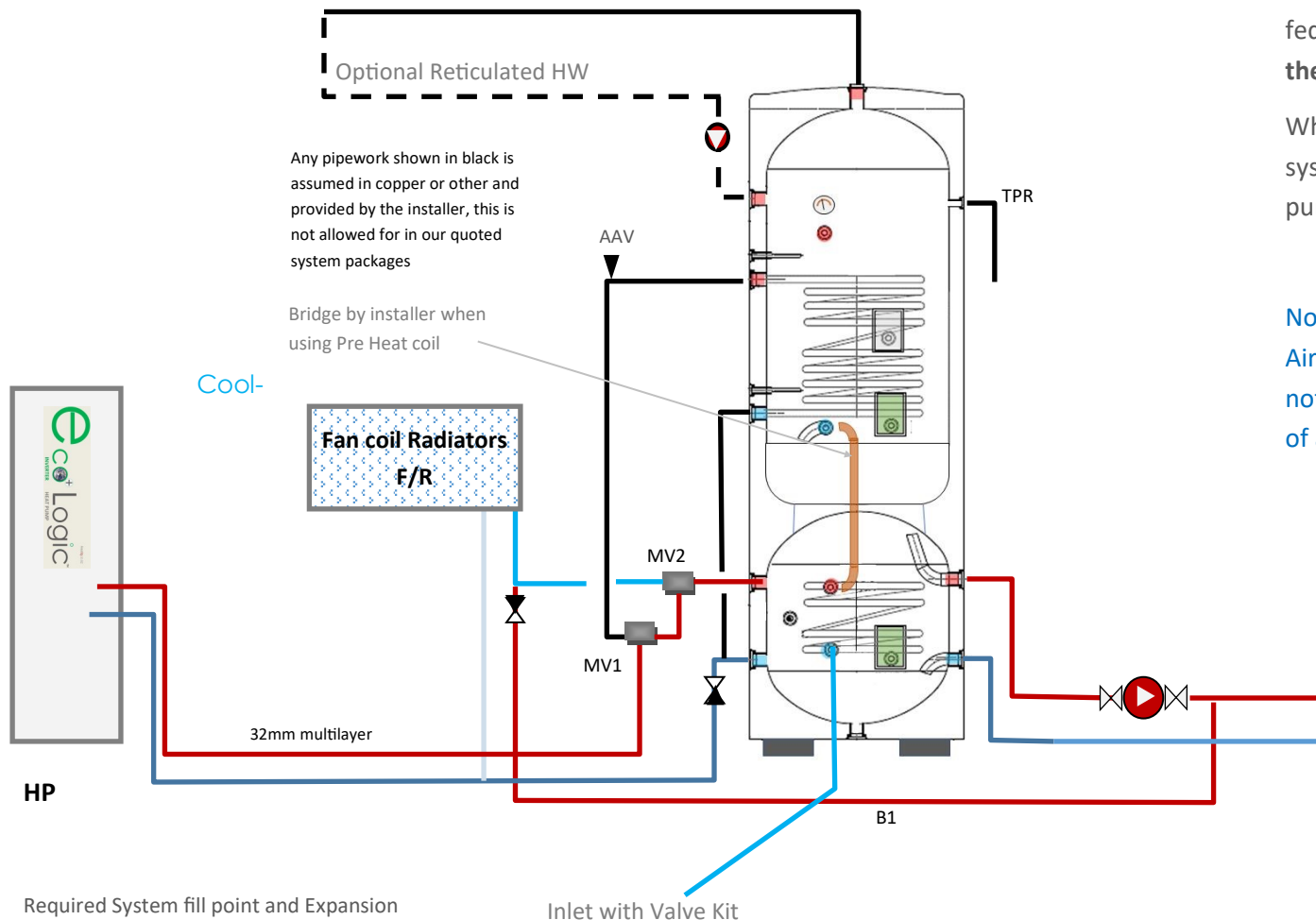

### Heat or Cool

Fan coils forming the **cooling** output system are fed via **MV2** when cooling is active, **in this mode the buffer is locked out of the system.**

When the fan coils are used as part of the **heating** system, The bridge **B1** is pumped via the system pump becoming the flow **MV2** is closed.

**Note:** cooling via an air to water heat pump is not Air conditioning. It offers limited capacity and will not notably reduce humidity. It should be thought of as a means to reduce temperatures not to chill.

### Heating output

This could under-floor, fan coils or conventional radiators .

Required System fill point and Expansion vessel are not shown

Wiring outline UFH or manifolded Radiators

1	HT sensor cable Supplied with HP
2	1.5mm Twin and earth to Relay JO2 By electrician
3	1.5mm Twin and Earth to 3 way valve
4	1.5mm Twin and Earth to Reticulated hot water pump
5	1.0mm Two core cable for potential free switching

	Suitably sized power supply cable
	Relay be electrician for switching of element via HP control (cable 2) Refer to HP manual
	Room or zone thermostats—No, as required by the system

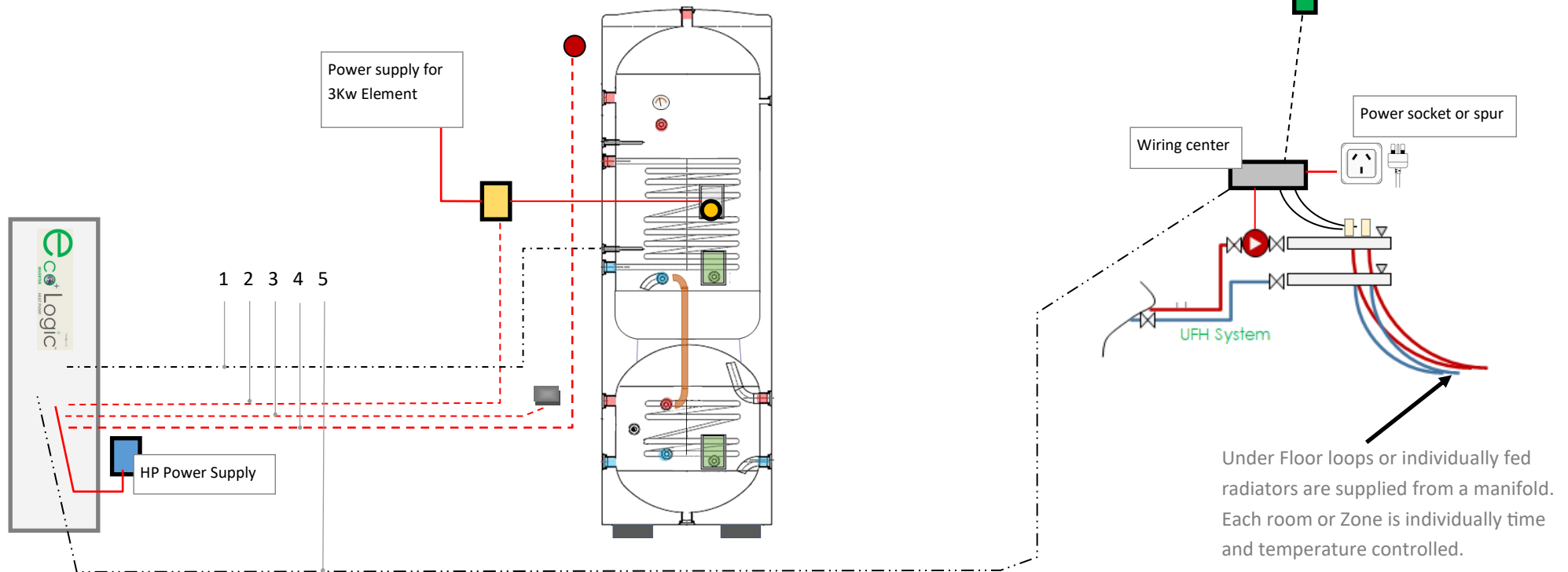

HP

## Wiring outline UFH & Fan coils

1	HT sensor cable Supplied with HP
2	1.5mm Twin and earth to Relay JO2 By electrician
3	1.5mm Twin and Earth to 3 way valve
4	1.5mm Twin and Earth to Reticulated hot water pump
5	1.0mm Two core cable for potential free switching

	Suitably sized power supply cable
	Relay be electrician for switching of element via HP control (cable 2) Refer to HP manual
	Motorised 3 way priority valve for HW supplied with 1m pre wired flex cable
	Room or zone thermostats—No, as required by the system

Note This mixed system is with the same delivery temperature to the floor and radiators. It is suitable where fan coil radiators are optioned that can output efficiently at lower temperature.

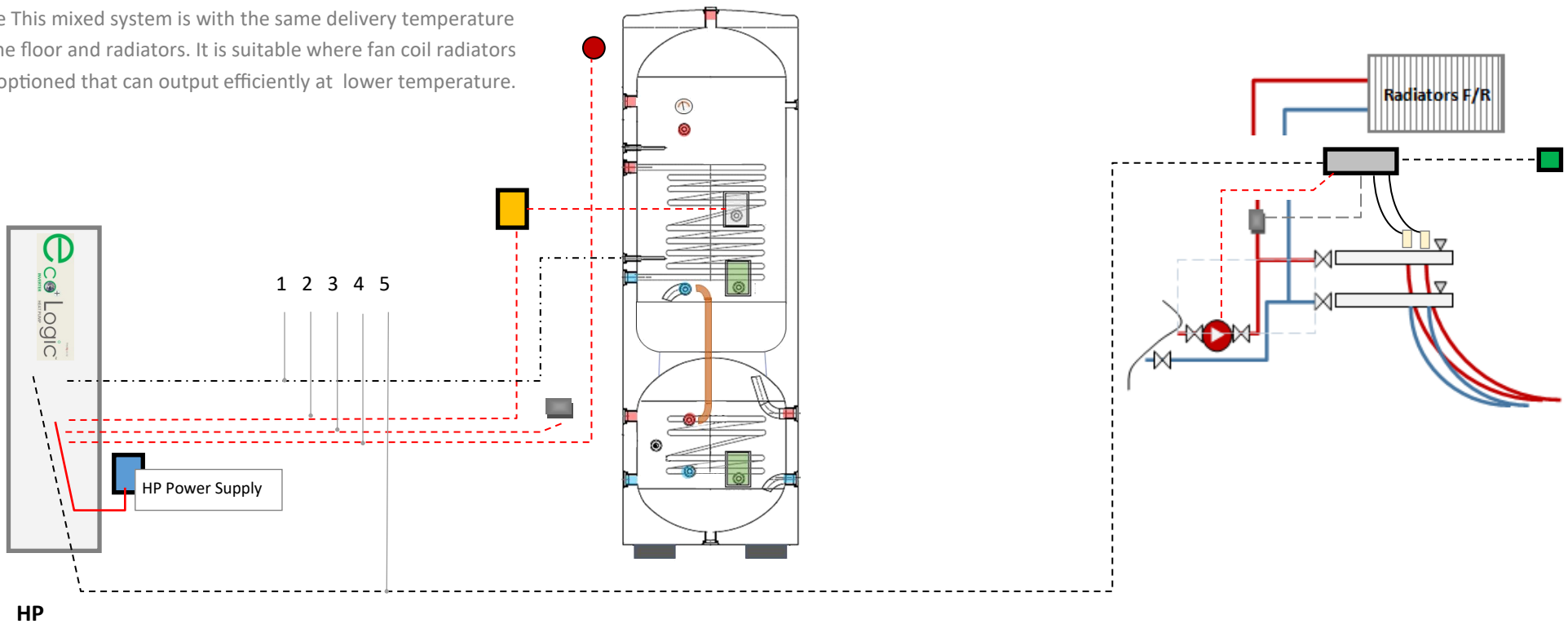

Sensor probe (1) should not run along side of 240V ca-

## Wiring outline, conventional radiators

With a traditional Flow and return pipe system.

Note For conventional radiators the HP output temperature will be raised It is wise to ensure radiators are big enough to provide enough heat from the HP delivery temperature . We recommend that radiator systems are zoned to provide heat for the zones at different times.

1	HT sensor cable Supplied with HP
2	1.5mm Twin and earth to Relay JO2 By electrician
3	1.5mm Twin and Earth to 3 way valve
4	1.5mm Twin and Earth to Reticulated hot water pump
5	1.0mm Two core cable for potential free switching

	Suitably sized power supply cable
	Relay be electrician for switching of element via HP control (cable 2) Refer to HP manual
	Motorised 3 way priority valve for HW
	Room or zone thermostats—No, as required by the system

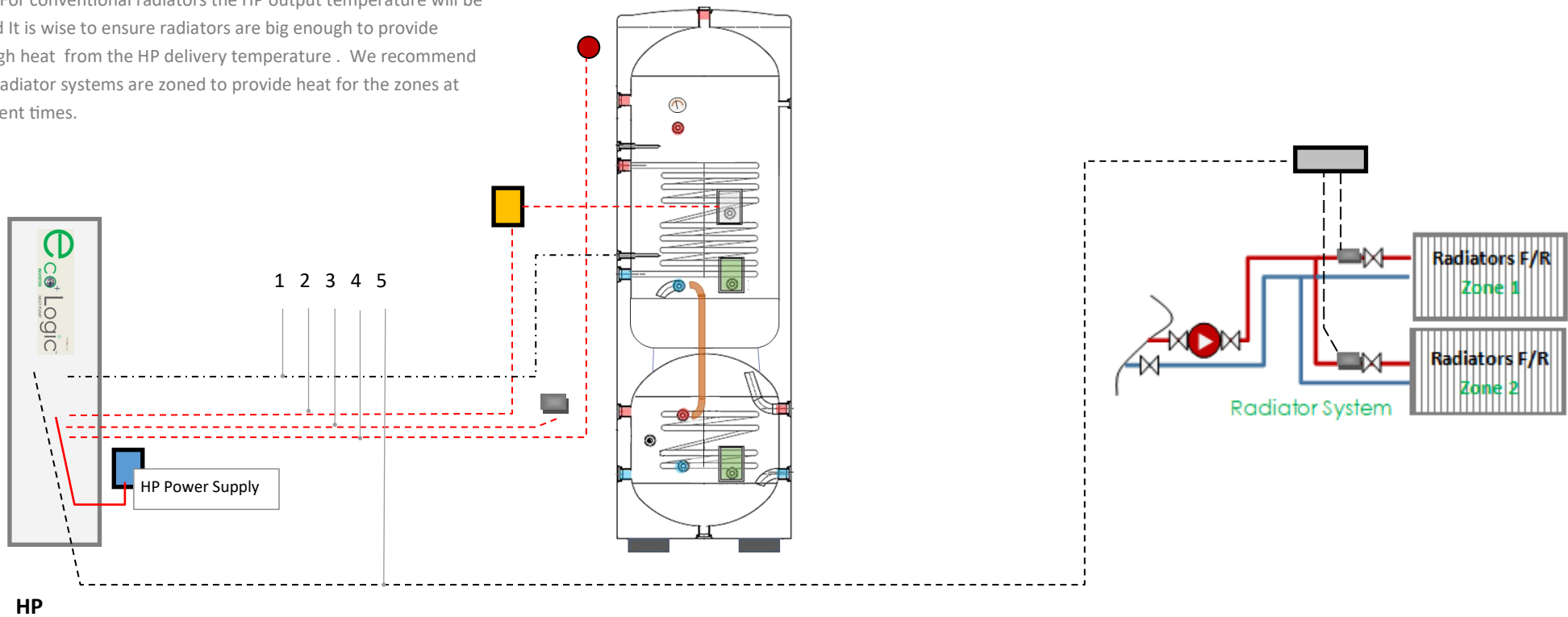





Sensor probe (1) should not run along side of 240V cables



Wiring outline : Heat & Cool

1	HT sensor cable Supplied with HP
2	1.5mm Twin and earth to Relay JO2 By electrician
3	1.5mm Twin and Earth to 3 way valve
4	1.5mm Twin and Earth to Reticulated hot water pump
5	1.0mm Two core cable for potential free switching
6	1.0mm Two core cable for Potential free Switching

	Suitably sized power supply cable
	Relay be electrician for switching of element via HP control (cable 2)Refer to HP manual
	Motorised priority diverter valve
	Room or zone thermostats—No, as required by the system
	Cooling activated—on off control

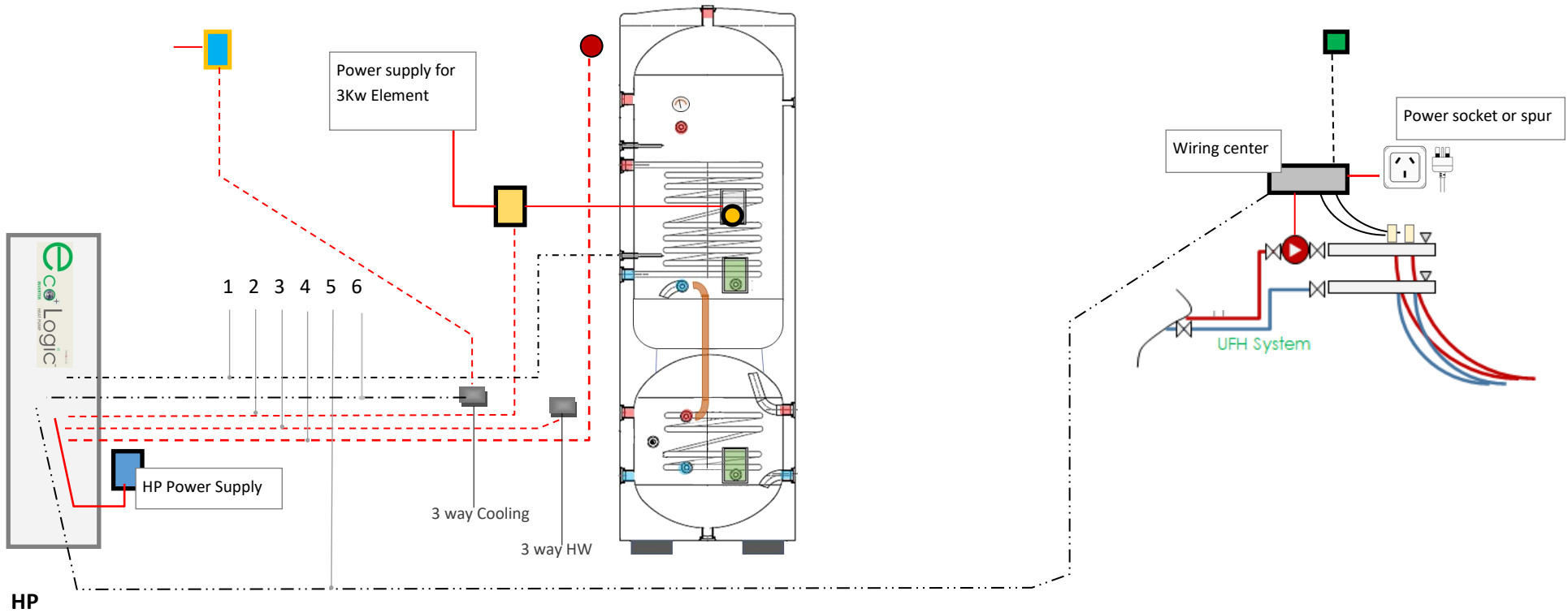

Sensor probe (1) should not run along side of 240V ca-

# Eco+Logic

Combi - Tank



## Solar PV ready

Two solar PV DC element ports included A 1 1/4" plug is provided for each.

We provide a contact thermostat at each port but do not include the PV suitable DC elements.

We also have differential thermostats with cylinder probes available.

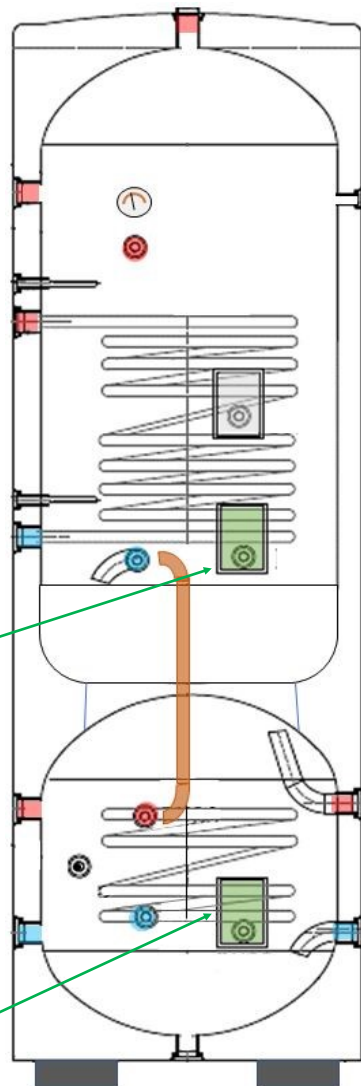

## Recommended Options

### Reduced Hot water run off



On/ off period controlled pump circulation of a reticulated hot water loop via your Eco+Logic heat pump can deliver hot water to localized tempering reducing run off and saving energy. IQ Order ref **HIQ 076** pump, is designed for this application. silently circulating Hot water at a pace that will not break down the HW cylinder stratification.

### Secondary HW module

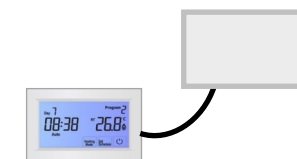

Our unique hot water module further enhances domestic hot water energy management via the following features...

1/ **Top of tank Triggering**, For energy frugal top up input by the element the upper cylinder pocket is used to trigger the element only when the upper level of the cylinder drops below a settable temperature. This feature is able to be one hour boost or in three settable time zones.

2/ **Manual Element override**, In the event of a HP outage the user has a simple override to turn the element on as required without the HP interface.

3/ **Interface with Legionella management**, allows the element to be controlled on via The Eco+Logic inverter HP's on board Legionella protection program.

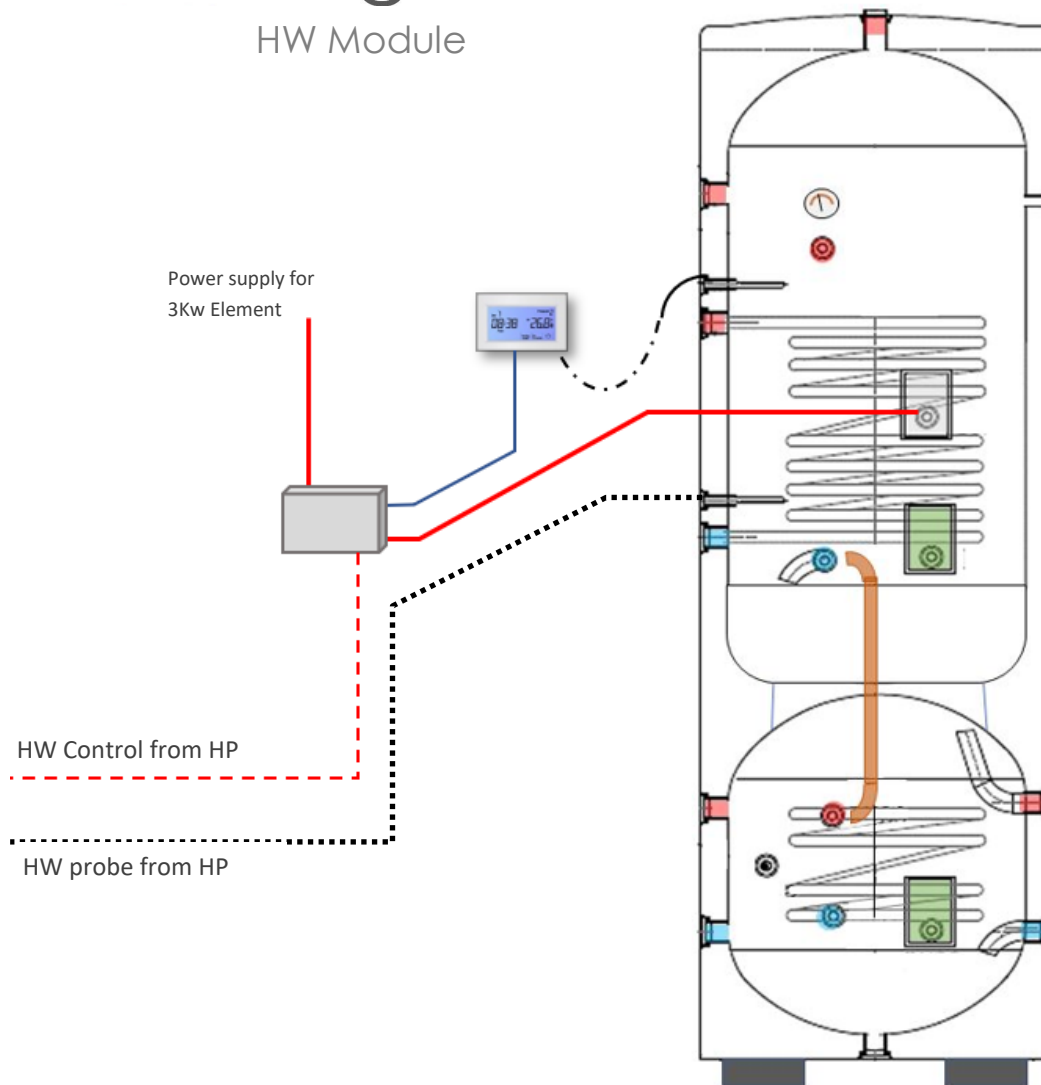

Module replaces Relay by electrician shown in preceding wiring details



### When the Hot water module is incorporated

The element is controlled by both the Module and the HP  
 The module allows controlled boost and user override of the element, whilst the HP remains constantly the primary heat input and source of control for Legionella protection.

### The advantage of this configuration

Via the upper sensor the element is only active and is managed if its use is required. When it is in use its input is fully controlled, the HP will heat more of the DHW requirement .

When the HP triggers a timed legionella control cycle, the lower probe, from the HP is in control, ensuring the required whole cylinder volume heating.

Additional energy savings are achieved.



**ENERGY EFFICIENT**

## Seismic Restraint of Storage water heaters 90-360 Litres

Paragraph 6.11.4 Extract from G12 NZ

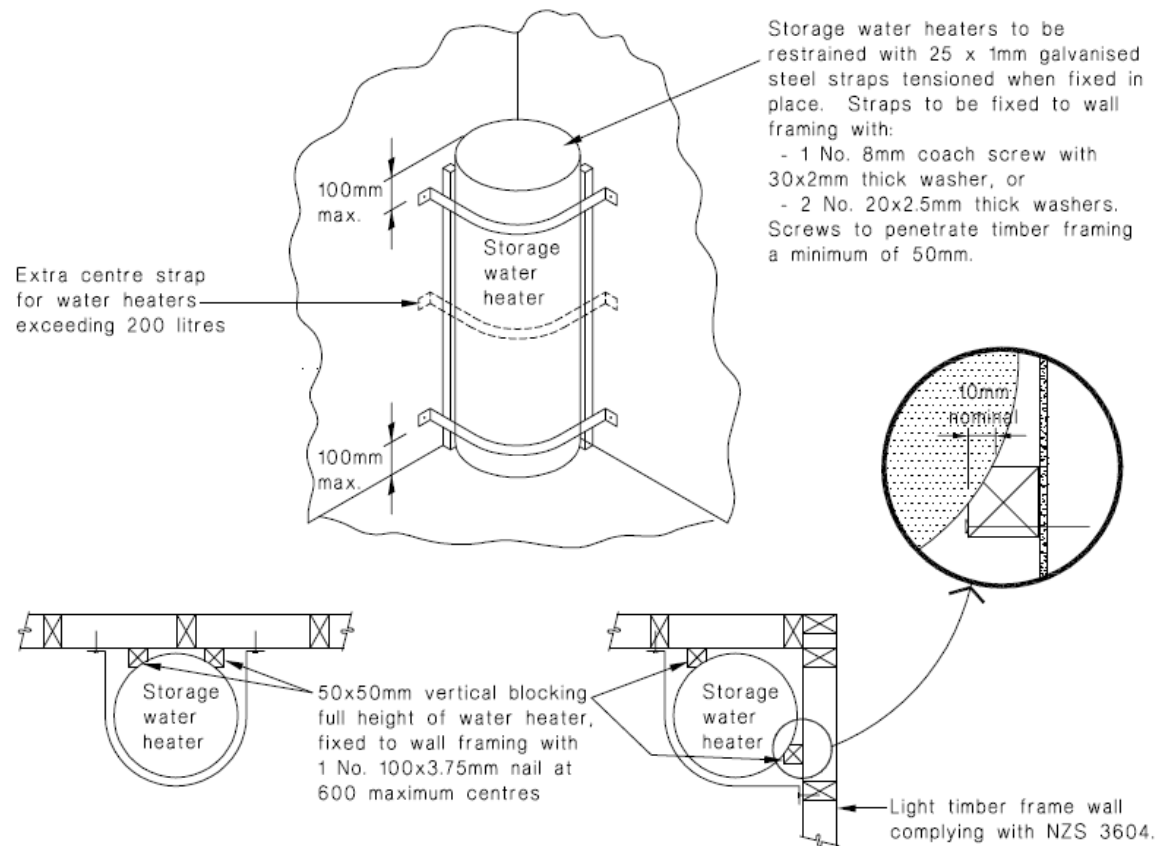

A Drain Tray must be used in all installations

Regardless of code which may require a drain tray A drain tray with a suitable drain connection must be included no claim will be accepted where failure to provide a drain tray leads to subsequential damage.

The drain tray is not Included.

## Inlet valving

**The following valving must be provided by the installer**

A TPR valve. This must be installed using PTFE/Teflon tape not with hemp and paste.

A cold pressure relief valve.

An inlet pressure limiting valve not exceeding 500 KPA must be fitted this should include a service valve and a strainer

**For 350 KPA inlet - a 700 KPA TPR with a 550 KPA cold relief**

**For 500 KPA inlet - a 850KPA TPR with a 700KPA cold relief**

A Non return Check valve must be included on the Cold inlet line before the cold relief valve.

**Warranty is void where the above items are not installed**

Where the water supply is limited (Rain water supply for example an expansion tank on the hot water cylinder is recommended.



[www.heatiq.co.nz](http://www.heatiq.co.nz)