

# LEGEE-D7

VACUUM MOP 4-IN-1 ROBOT



## User Manual



LEGEE SLAM

TALENT CLEAN

TANGLESS SUCTION

# Table of Contents

Important Safety Instructions	- 1-
Laser Safety	- 3-
Copyright & Trademarks	- 3-
Disclaimer	- 3-
Limited Warranty	- 3-
Product Overview	- 4-
Product Specifications and Accessories	- 6-
Installation	- 7-
Start Cleaning	- 8-
App Instructions	- 9-
Maintenance	- 10-
Common Issues (FAQ)	- 13-

## Important Safety Instructions

When using an electrical appliance, basic precautions should always be followed, including the following:

**READ ALL INSTRUCTIONS & SAVE THIS USER MANUAL**

**This appliance can be used by children aged from 8 years and above and persons with reduced physical, sensory or mental capabilities or lack of experience and knowledge if they have been given supervision or instruction concerning use of the appliance in a safe way and understand the hazards involved. Children shall not play with the appliance. Cleaning and user maintenance shall not be made by children without supervision.**

### WARNING

Do not attempt to repair your LEGEE-D7 yourself. Disassembling the device may cause injury to you. Unauthorized repairs or modifications could result in permanent damage to the device and may affect your warranty coverage and regulatory authorizations. Any service other than regular cleaning should be only performed by an authorized service representative. Contact your local waste management authority to follow local disposal regulations and never dispose the device and rechargeable batteries with normal household waste.

### GENERAL

- This product is designed for indoor floor cleaning only, do not use it outdoors, on greasy surfaces or any uneven surface (such as a sofa), or for commercial or industrial purposes.

- Do not fill the water tank with any liquid other than pure water or the LEGEE detergent. Other detergents are not allowed.
- Keep the device and accessories away from children.
- Keep the device in dry and cool place, away from direct sunlight, naked flames, heat, humidity, water and any other liquids.
- Do not store the device near oil, combustible spray or flammable materials.
- Product operating temperatures: 0°C ~40°C (32°F ~104°F)
- Product storage temperatures: -10°C ~50°C (14°F ~122°F)
- Do not use the device if any part or any accessory is damaged or defective.
- Before using the device, clear away as much objects as you can from the floor especially electric cords, glass pieces or any other objects that could tangle, block, or damage the device.
- Do not use the device on the shag/frieze carpet, the device could be trapped and wet or damage the carpet.
- The device may not work properly on the dark-colored carpet.
- Do not leave any fragile objects at the edge of tables and cabinets where they could be easily knock down by the device during cleaning.
- Keep your children and pets away from the cleaning path.
- Switch off the power and disconnect the power plug before dismantling, assembling or cleaning the device, power adapter and charging station.
- Do not clean the device by spraying water on it or immersing it in water. The device is not waterproof.

## **BATTERY & CHARGING STATION**

- Connect the power adapter to a power source that matches the specifications. The power adapter is designed for connection to hazardous electrical voltages. Do not attempt to repair the adapter. Replace the whole unit if it is damaged or exposed to high moisture. Consult local HOBOT dealer for help and maintenance.
- Make sure the device, power adapter and charging station are not trapped under heavy objects.
- Allow adequate ventilation around the device, power adapter and charging station. Do not cover them with objects.
- Do not use the device, power adapter and charging station in a strong magnetic field, humid or high heat environment.
- Use the original power adapter, battery and charging station that came with the device. Use the third-party components may result in damage, malfunction and/or danger.
- This device contains batteries that can only be replaced by professionals.
- Battery can explode, catch fire, and/or cause burns if disassembled, crushed, cut, punctured, short-circuited, incinerated, recharged (disposable cells), or exposed to water, fire, or temperatures above 60°C (140°F).
- If the device is not in use for a long period of time, store it in a dry and safe location. The battery will need to be charged every 3 months to maintain battery life.
- Never operate this device if the cord or power adapter is damaged. Ensure the power cord is not stretched or exposed to sharp object or edges.

# Laser Safety

The laser distance sensor of this product meets the standards for Class I Laser Products in IEC 60825-1:2014 and will not generate hazardous laser radiation.

# Copyright & Trademarks

Copyright © 2022 by HOBOT® Technology Inc. All rights reserved. No part of this publication may be reproduced, transmitted, transcribed, stored in a retrieval system or translated into any language or computer language, in any form or by any means, electronic, mechanical, magnetic, optical, chemical, manual or otherwise, without the prior written permission of this company. All other logos, products, or company names mentioned in this manual may be the registered trademarks or copyrights of their respective companies, and are used for informational purposes only.

# Disclaimer

HOBOT Technology Inc. makes no claims or warranties, either expressed or implied, with respect to the contents hereof and specifically disclaims any warranties, tradability or suitability for any particular purpose. Furthermore, HOBOT Technology Inc. reserves the right to revise this publication and to make changes from time to time in the contents hereof without obligation of this company to provide notification of such revisions or changes. The user should follow the instructions provided in this user manual, but is ultimately responsible for assessing placement and safety when using this cleaning tool.

# Limited Warranty

If there are defects in your LEGEE due to faulty materials, poor workmanship, or malfunction within the warranty period from the date of purchase or delivery, please immediately contact a local retailer or local authorized dealer for repairs or replacement.

This limited warranty does not cover:



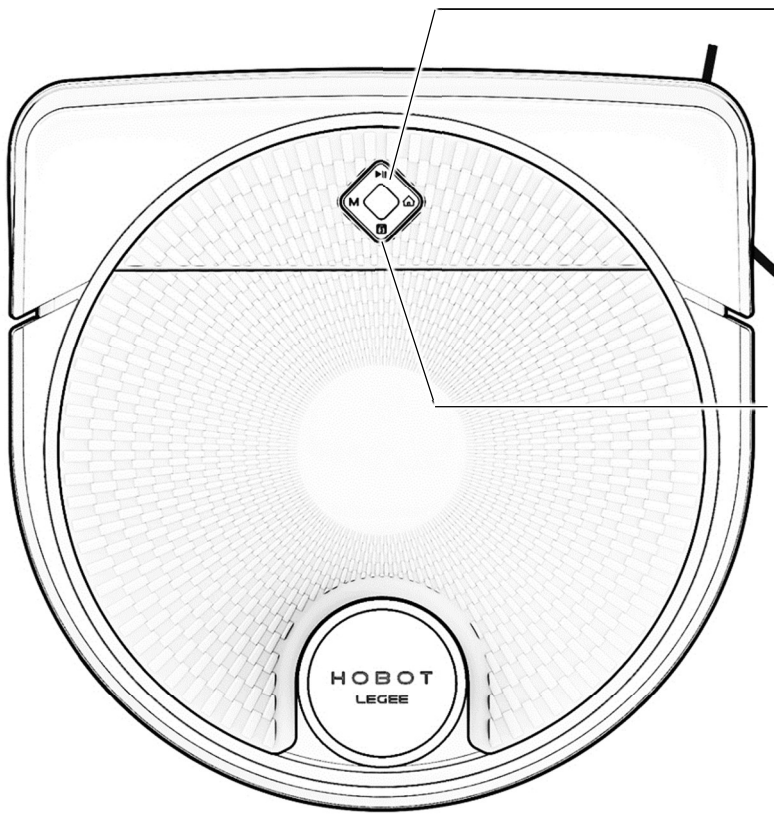

- Normal wear and tear, including parts that might wear out over time (side brush, brushroll, cleaning cloth, caterpillar belt, spray nozzle and filter, etc.)
- Reduction in battery runtime due to battery age or use, as the life of the battery and number of times the device is used.
- Transit, delivery or accidental damage or misuse and abuse that is not in accordance with the instructions.
- Faults or damage caused by:
  - Negligent use, misuse, abuse or careless operation of the device.
  - Use of the device which is not in accordance with this manual.
  - Use of anything other than normal domestic household purposes in the country in which it was purchased.
  - Use of parts not assembled or installed in accordance with this instruction.
  - Use of any unauthorized parts and accessories. Please contact a local retailer or local authorized dealer for spares and accessories.
  - Faulty assembly or installation.
  - Repairs or alterations carried out by parties other than HOBOT authorized dealer.

# Product Overview

## TOP VIEW



### Control Buttons

-  Start/Pause Cleaning
-  Return to Charging Station
-  Stop Cleaning/Child Lock (press 3 sec.)
-  Switch Cleaning Mode

### LED Indicator

Orange	Battery Charging
Orange Flashing	Low Battery
Green	Battery Fully Charged
Blue	Wet Mopping
White	Dry Mopping
White Flashing	Connecting
White & Blue	Spraying Water
Orange & Blue	Search for Charging Station
Orange & Green	Child Lock Engaged

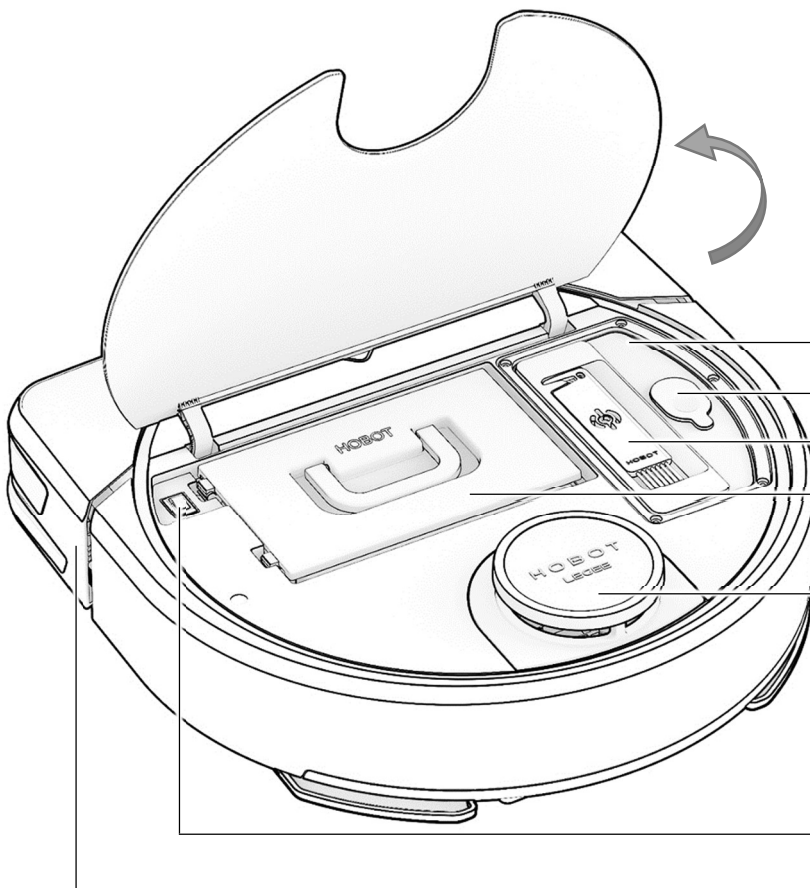

- Water Tank
- Water Tank Lid
- Cleaning Tool
- Trash Bin
- LiDAR Sensor
- Power Switch
- Bumper

# BOTTOM VIEW

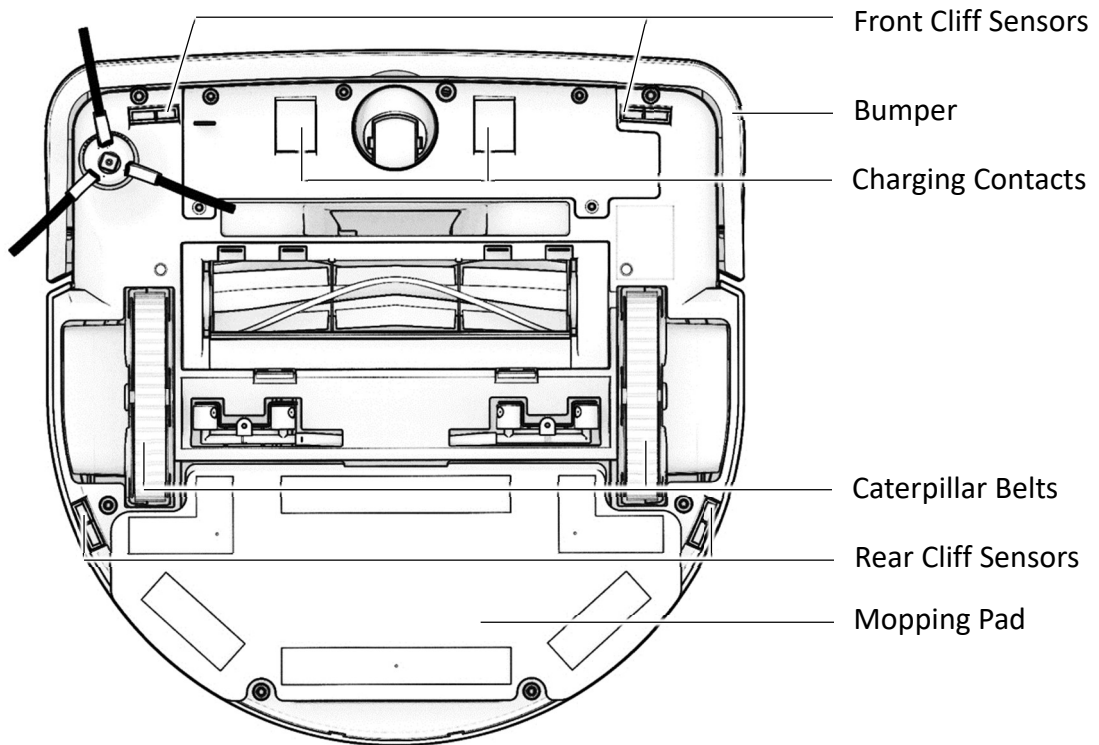
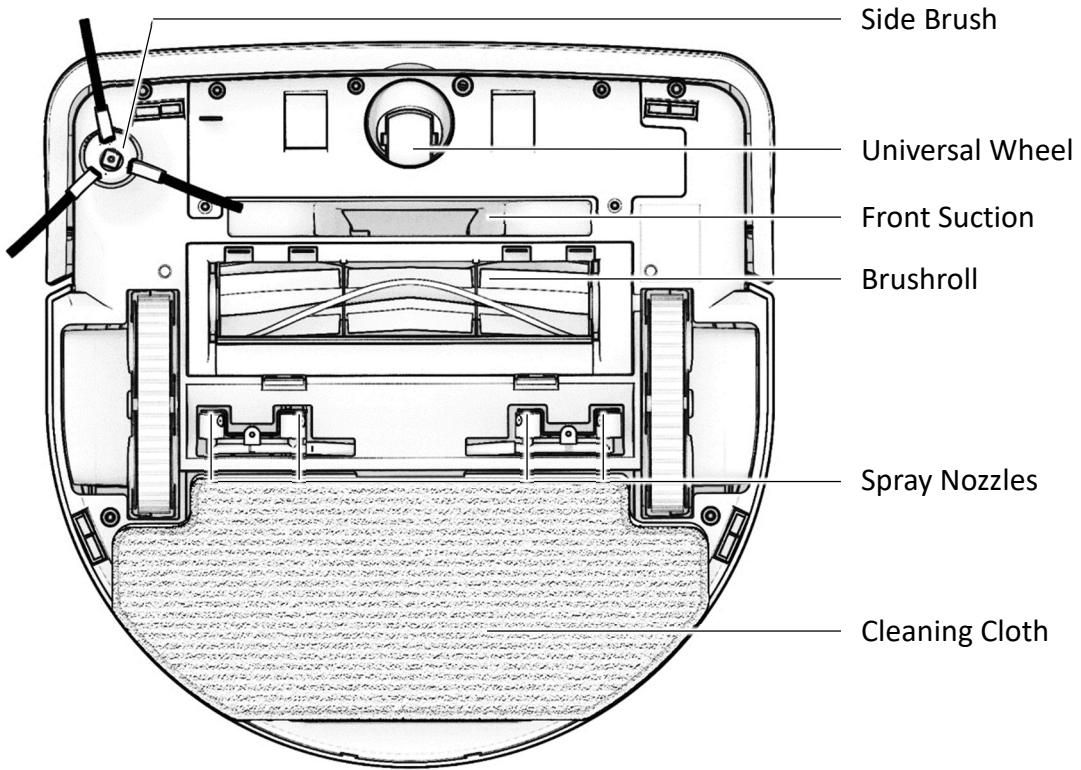

## TRASH BIN

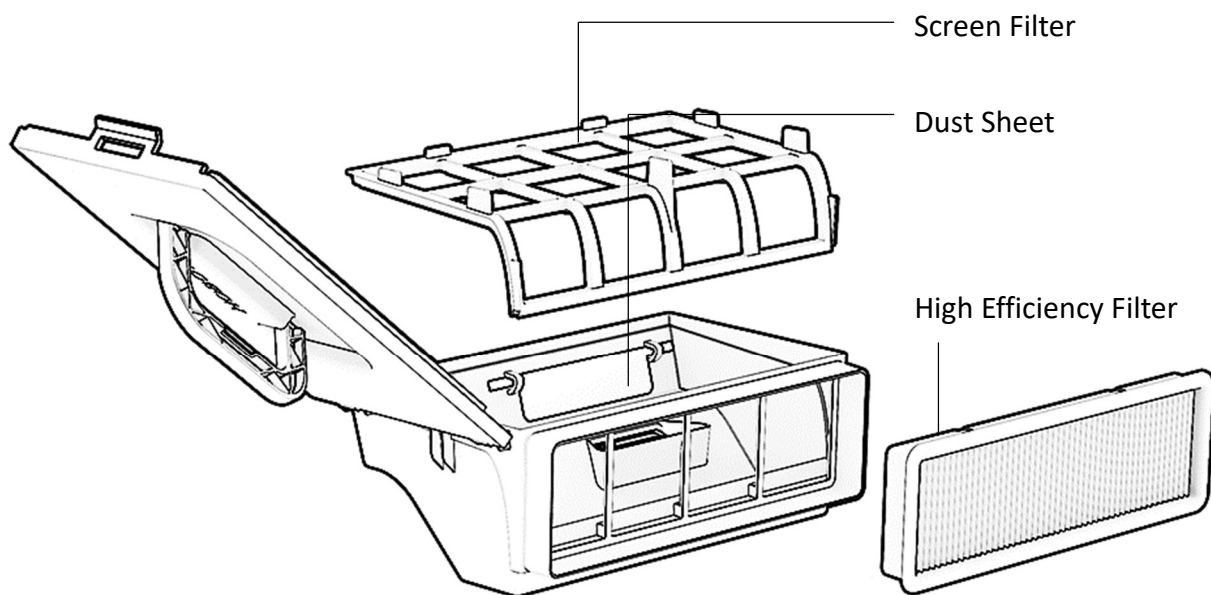

## CHARGING STATION

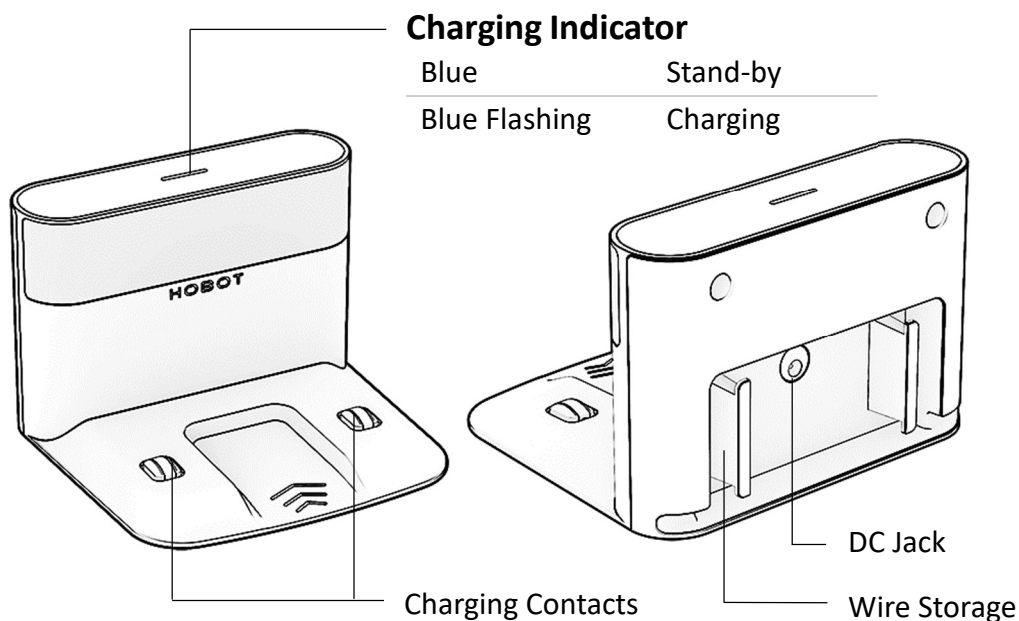

## Product Specifications and Accessories

<b>Model</b>	<b>LEGEE-D7</b>
Wi-Fi	802.11a/b/g/n/bt
Dimensions (L × W × H)	340 × 339 × 97.5 mm
Li-ion Battery	Rated Capacity: 4400mAh Cell Capacity: 4900mAh

<b>Charging Station</b>	
Dimensions (L × W × H)	160 × 147 × 110 mm
Input Voltage	100~240 VAC, 50~60 Hz
Power Consumption	19V/1.05A, 19.95W

- LEGEE-D7
- Charging station
- AC adapter
- Water bottle
- Microfiber cleaning cloth
- Spray nozzles pack
- Side brushes
- High efficiency filter
- User manual

# Installation

## Important Notes Before Cleaning

Put away objects including wires, cloths, slippers, fragile objects...etc. on the floor to improve cleaning efficiency and safety.

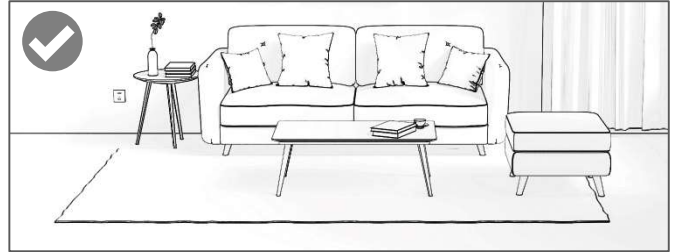
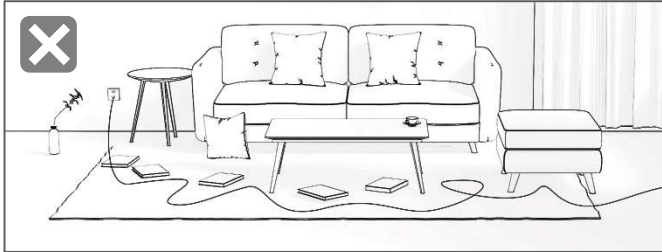

### 1. Position the Charging Station

Peel off the backings paper from the bottom of the charging station and keep the charging station on a level surface, flat against a wall.

Clear the objects around the charging station.

Connect the power cord to the charging station and tidy wires from the floor.

To ensure a better user experience of the App, place the charging station in an area with good Wi-Fi coverage.

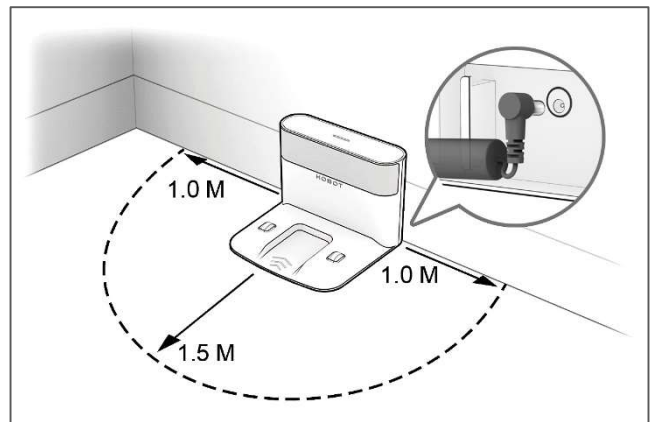

### 2. Power on & Charge your LEGEE

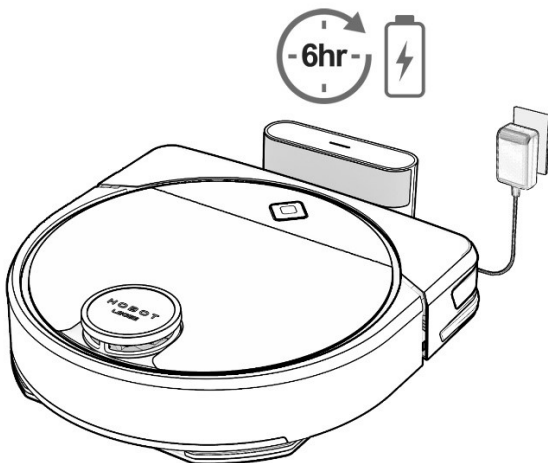

Plug power adapter into the charging station and place the flat end of the robot against the charging station.

Before the first time of use, fully charge the battery for at least 6 hours until the LED indicator green light is ON.

To maintain the performance of the Li-ion battery, keep your LEGEE charged.

### 3. Install the Side Brush

Press down the side brush until you hear a click sound.

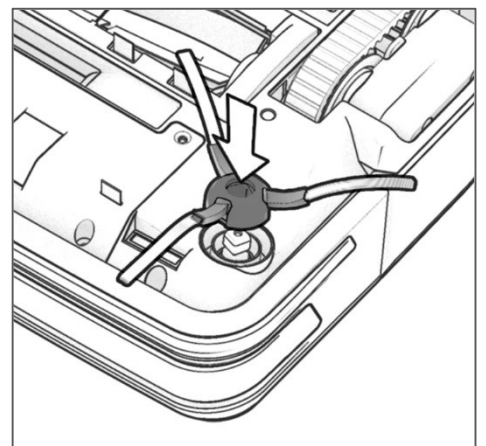



## 4. Attach the Cleaning Cloth

Attach the cleaning cloth flatly to the mopping pad.

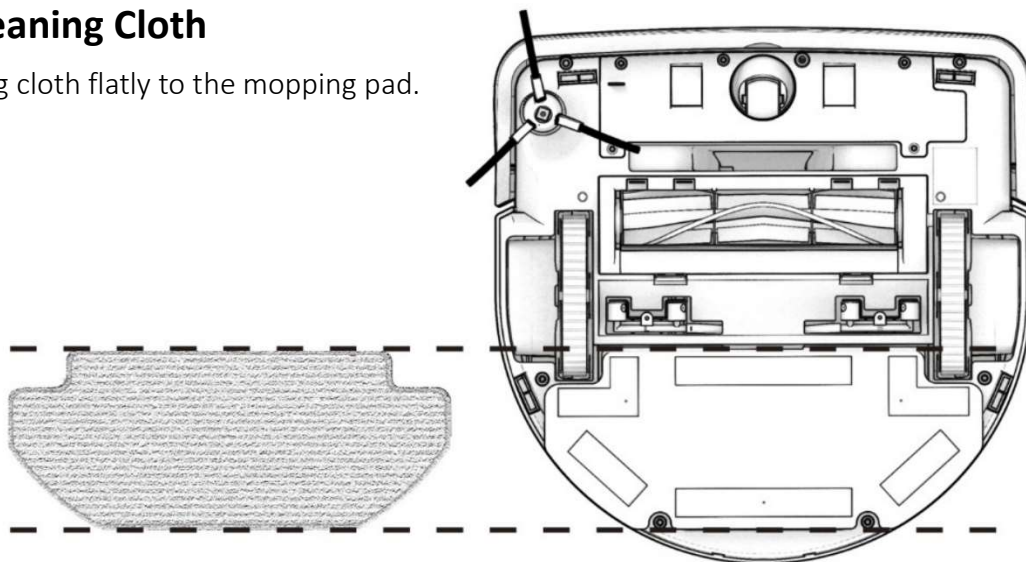

## 5. Fill the Water Tank

1. Open the water tank lid, fill it with pure water or LEGEE detergent.

2. Close the lid tightly.

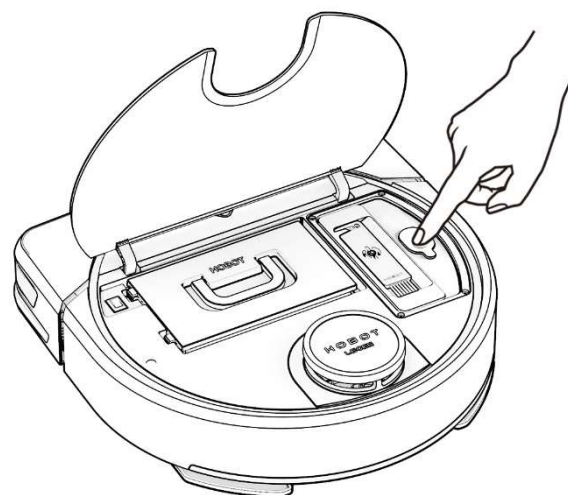
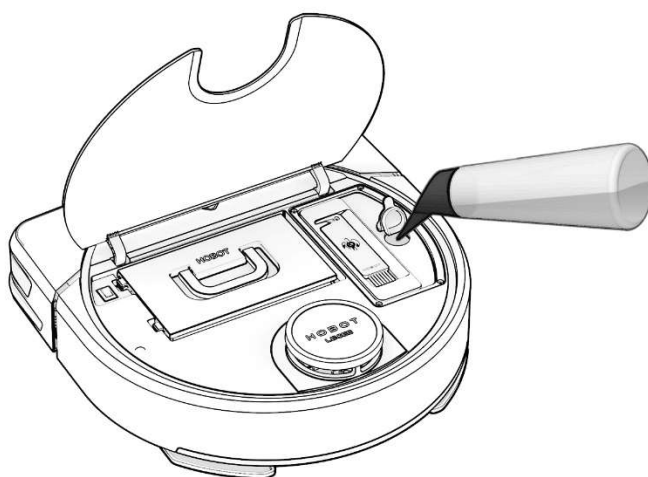

\*DO NOT use any other detergent or liquid to prevent blockage of the pipes and the spray nozzles.

## Start Cleaning

Switch on LEGEE. You can control in two ways: with the buttons on the device or with the LEGEE App.

### Control your LEGEE with the buttons on the device



- ▶|| Start/Pause Cleaning
- 🏠 Return to Charging Station
- 🔒 Stop Cleaning/Child Lock (press 3 sec.)
- M Switch Cleaning Mode

### Control your LEGEE with the LEGEE App

Please see "App Instructions"

# App Instructions

## 1. Download the LEGEE App

LEGEE-D7 can be dynamically controlled by the App through Wi-Fi or Hotspot. Search for “LEGEE” in the App Store or Google Play or scan the QR code on the right to download and install the App.

- LEGEE supports 5G/2.4G Wi-Fi
- Turn on the Bluetooth and Wi-Fi on your phone



## 2. Create a HOBOT Account/Quick Login



### HOBOT account

Create your HOBOT Account and control your LEGEE with different devices. The only thing stored in your HOBOT Account is the device’s initial name. All customized settings are stored on the device and will never be accessible via HOBOT account. When you log in to your HOBOT account on another smartphone, HOBOT account will help you to link to the devices associated to your account and retrieve the data stored on your device for you.

### Quick Login

Login to your social media account and start using the App in just a few seconds.

## 3. Start Cleaning with the LEGEE App

1. Select a cleaning mode from the Talent Clean menu.
2. Tap  to proceed.
3. Tap  to start cleaning.
4. When cleaning is completed, save the map to create a default map.

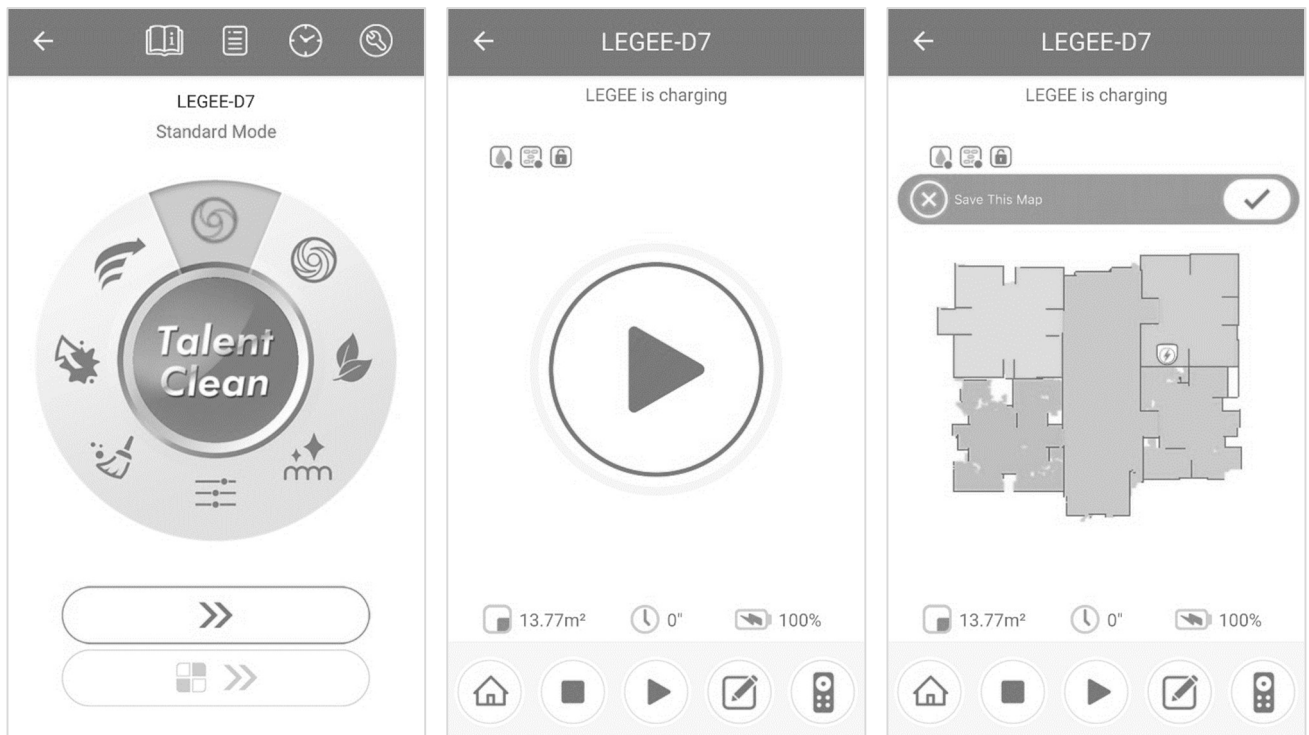

# Maintenance

Please maintain LEGEE according to the following guidelines for optimum performance:

Part	Care Frequency	Replacement Condition*
Trash Bin & Screen Filter	After each use or follow App's reminder.	N/A
High Efficiency Filter	After each use or follow App's reminder.	When it is too dirty (when the App shows that the trash bin is full even after you've emptied it and washed the filter)
Side Brush & Brushroll	After each use or tangled by hair.	When it is too dirty or when it is worn out and bristles are falling off.
Cleaning Cloth	After each use.	When it is too dirty or when it is worn out.
Spray Nozzle	When nozzle is clogged.	When it is clogged and cannot be cleaned with the pin.
Sensors & Charging Contacts	Before each use or follow App's reminder.	N/A
Universal Wheel	After each use or tangled by hair.	N/A

\*Contact a local retailer or authorized dealer for additional consumable spare parts.

## Brushroll

1. Push open the brushroll cover.

2. Take out the brushroll.

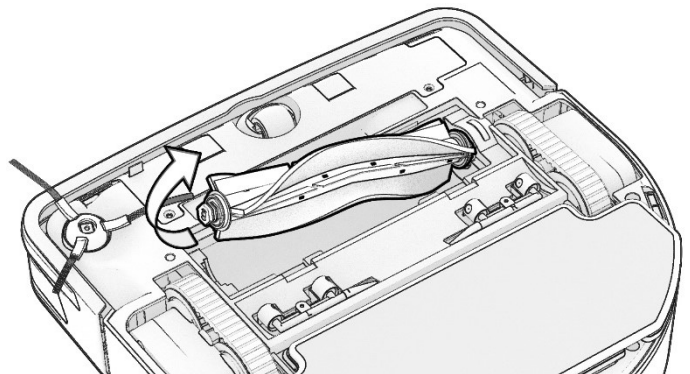
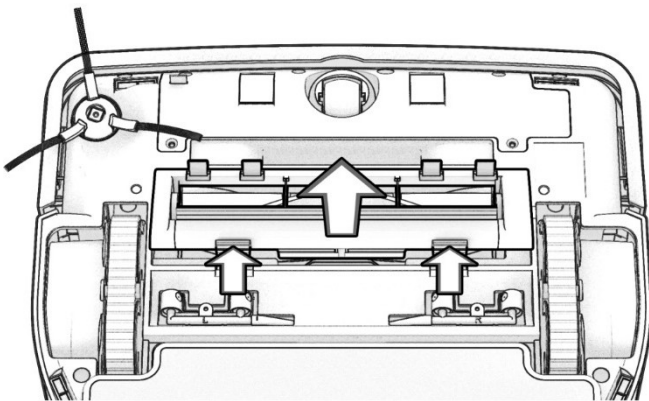

3. Use the cleaning tool to cut loose the tangled hair and debris to clean the brushroll, rinse then dry when needed.

4. Reinstall the brushroll.

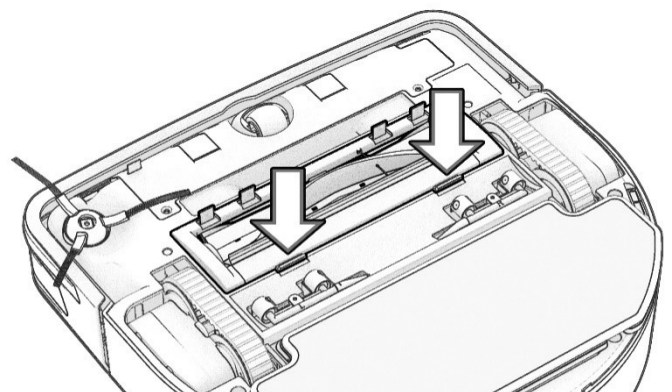
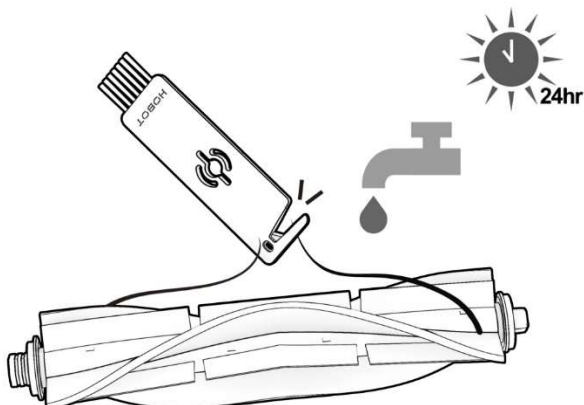

## Side Brush

1. Pull off the side brush from the device and remove any tangled hair or debris.

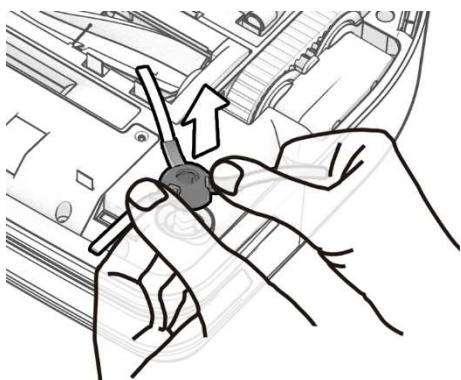

2. If necessary, rinse the side brush with warm water to clean dirt off and restore it to its original shape.

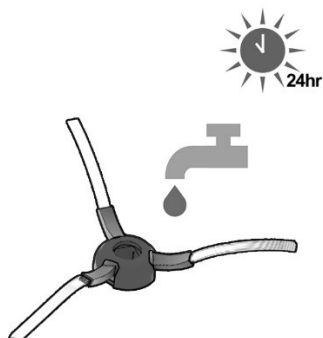

3. Reinstall the side brush. Push down until you hear a click sound.

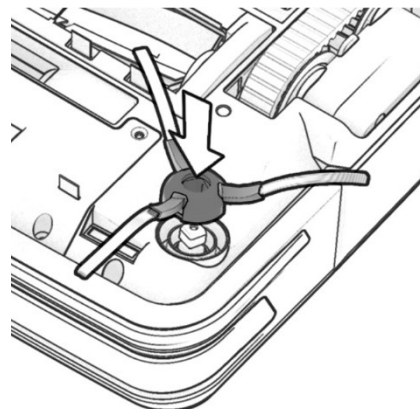

## Trash Bin

1. Take out the trash bin by lifting the handle.

2. Remove the screen filter and empty the trash bin.

3. Wash and air-dry the trash bin.

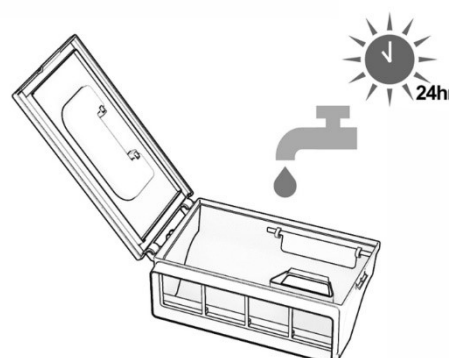
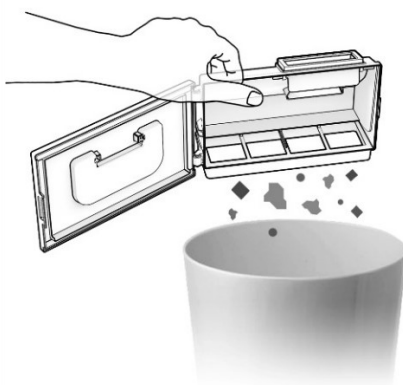
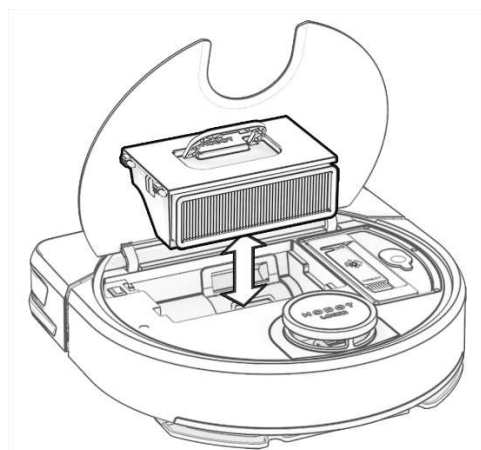

## Screen Filter & High Efficiency Filter

1. Shake off debris by tapping the filters against your trash container.



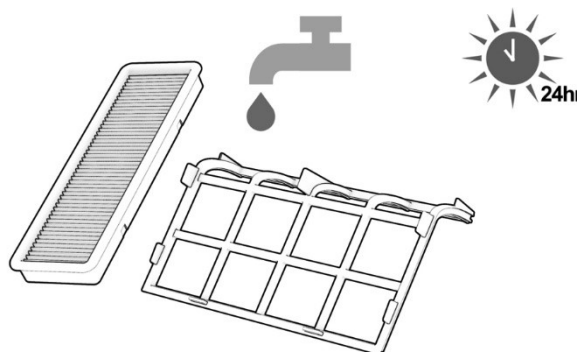
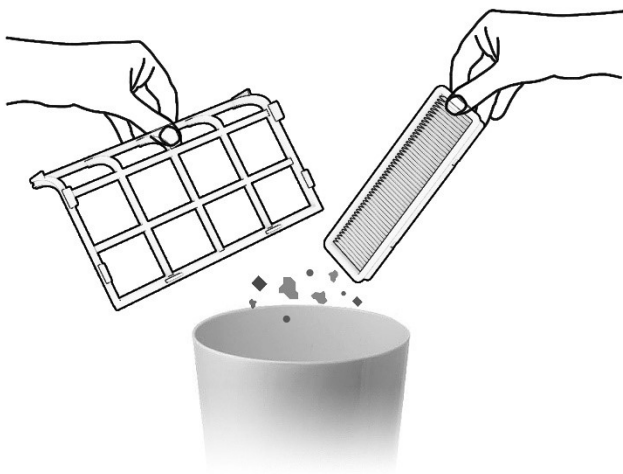

2. Rinse the filters if necessary. Do NOT rub the filters or use high-pressure water. Be sure to leave the filters to dry thoroughly before reinstalling them.



## Cleaning Cloth

You can wash the cleaning cloth in two ways:

1. Hand washing: Thoroughly wash the cloth with warm water and general-purpose laundry detergent.
2. Washing machine: Wash using the warm cycle, then air dry.

	Wash under 40°C (104°F)
	Do not bleach
	Do not tumble dry
	Do not iron.
	Do not dry clean.

\*A dirty cleaning cloth will decrease the mopping performance. Always start with a clean cloth.

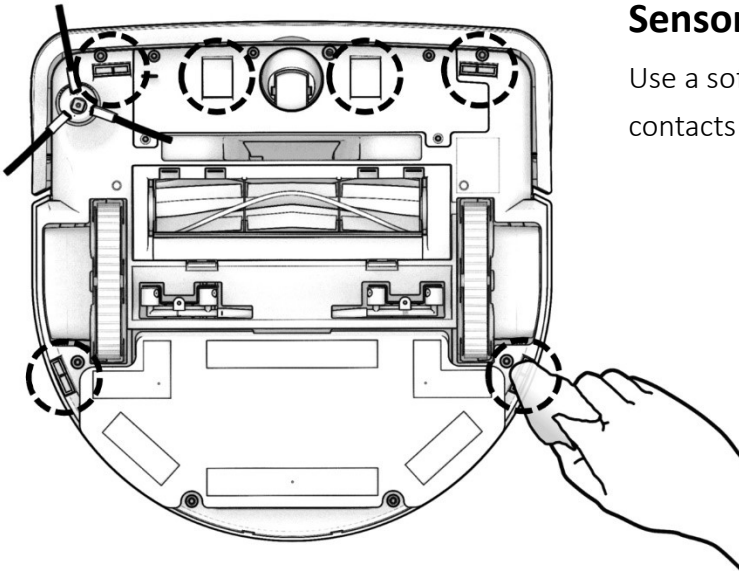

## Sensors & Charging Contacts

Use a soft dry cloth to wipe and clean the charging contacts and all sensors.

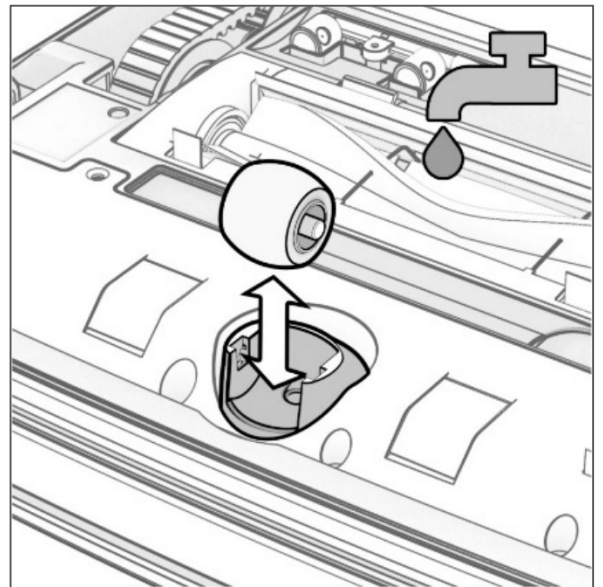

## Universal Wheel

Pull up the universal wheel and clear the hair, rinse and dry when needed

## Spray Nozzle

To unclog the spray nozzle:

Clean the spray nozzle with the push pin.

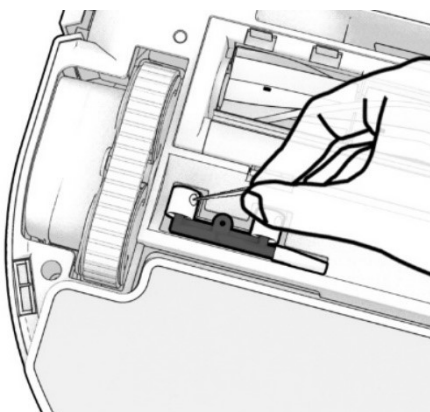

To replace the spray nozzle:

1. Use a screwdriver to loosen the screws holding the spray nozzle in place.

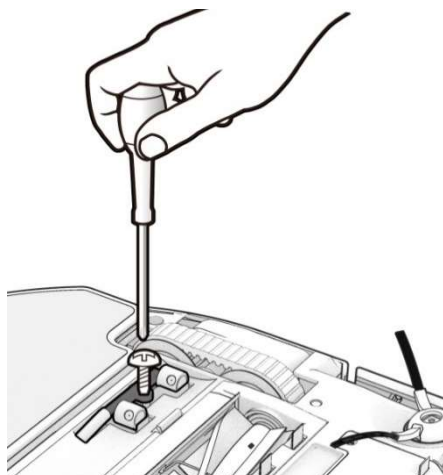

2. Replace the old nozzles with new ones, then reinstall the nozzles.

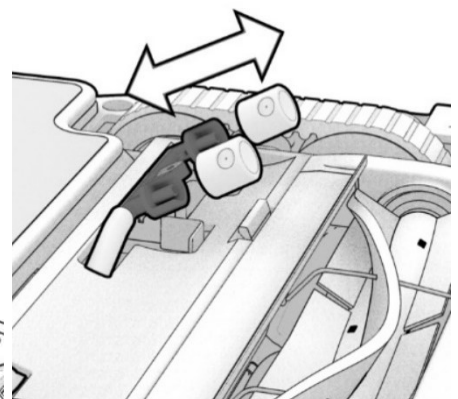

# Common Issues (FAQ)

Case	Solution
Cannot start LEGEE.	<ul style="list-style-type: none"> <li>• Check if the power is switched ON and the battery is fully charged.</li> <li>• If LEGEE can't be started by the on-device buttons, please check if the child lock is engaged (orange &amp; green light flashing), press the child lock button for 3 seconds to disengage.</li> </ul>
LEGEE returns to the charging station without completing the cleaning task.	<ul style="list-style-type: none"> <li>• The battery is low (orange and blue light flashing). LEGEE will resume cleaning after it's sufficiently charged.</li> <li>• If LEGEE returns to the charging station with sufficient power:               <ul style="list-style-type: none"> <li>- LEGEE may have misjudged the landscape due to the floor molding or due to moving furniture, closed doors and considered the task completed. LEGEE could also be blocked by narrow hallways or doorways so make sure to clear away the obstacles.</li> <li>- Please check if there are virtual barriers blocking the way so LEGEE considered the task completed.</li> <li>- Check if you have only chosen specific rooms instead of the entire house for the current cleaning task.</li> </ul> </li> </ul>
LEGEE cannot return to the charging station.	<ul style="list-style-type: none"> <li>• Place the charging station in an open space or clear the objects around it and clean the sensors with clean dry cloth.</li> <li>• Check if the adapter is properly connected to the charging station and is plugged into the power socket, the charging indicator will show blue light</li> <li>• There is adhesive—which leaves no stain on the floor—under the charging station for fixation, please make sure the charging station is firmly fixed on the ground.</li> </ul>
LEGEE does not resume the unfinished task after charging.	Check if it's under the Do Not Disturb period.
LEGEE does not start charging.	<ul style="list-style-type: none"> <li>• Check if the adapter is properly connected to the charging station and is plugged into the power socket.</li> <li>• The charging indicator will flash blue light when charging.</li> <li>• Poor contact with the charge contacts. Please switch off the power and remove the power source from the charging station. Clean all charging contacts by using a clean cloth with rubbing alcohol to remove the oxide then try again.</li> </ul>
Tips when charging LEGEE.	<ul style="list-style-type: none"> <li>• It is advised to keep LEGEE switched on when charging, LEGEE will be able to return to the charging station automatically in case LEGEE is moved.</li> <li>• The power consumption is very low when LEGEE is standing by, letting LEGEE stay connected to the charging station can help to maintain the battery's best performance.</li> </ul>
The cleaning result is less satisfying.	Switch off LEGEE, clean/change the side brush, empty the trash bin, and wash/change the high efficiency filter and the cleaning cloth.
LEGEE does not spray water.	<ul style="list-style-type: none"> <li>• Check if there is water in the water tank.</li> <li>• Test the spray nozzles using the  button in the App, it will make LEGEE to spray once.</li> <li>• If LEGEE does not spray water, please clean the spray nozzles or replace with new ones.</li> </ul>
The side brush does not spin normally.	Remove the side brush from the device, clean the hair between the side brush and the device and reinstall it.

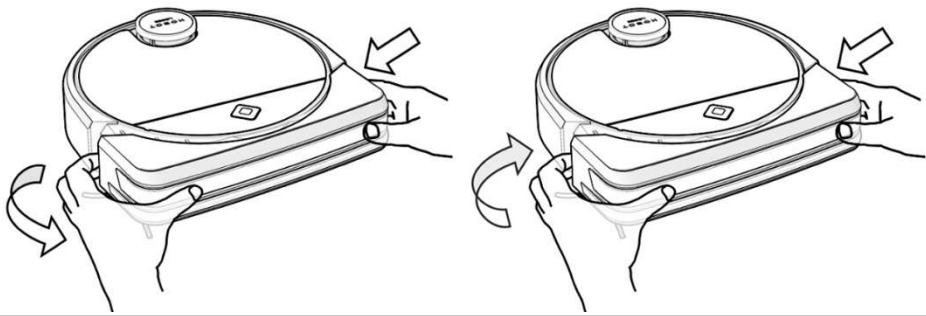
<p>LEGEE works/moves abnormally.</p>	<ul style="list-style-type: none"> <li>• Switch off LEGEE, clean the side brush and cliff sensors.</li> <li>• Check if the cleaning cloth is firmly attached to the device and if it's too dirty.</li> <li>• Check if the bumper is properly installed.             <ol style="list-style-type: none"> <li>1. Press the right end of the bumper and pull the left end to detach the bumper from the device.</li> <li>2. Wipe clean the bumper and reinstall it.</li> </ol> </li> </ul> 
<p>How does the cliff sensors work?</p>	<p>The cliff sensors can avoid the damage to LEGEE by preventing it to fall off the cliffs such as stairs or the edge of the floor. To avoid LEGEE to enter the recessed area, please set a virtual barrier in the App.</p>
<p>Can LEGEE detect glass or reflective material?</p>	<p>LEGEE is unable to detect glass or reflective material in front of it, please set a virtual barrier around these areas in the App.</p>
<p>LEGEE does not play the voice prompts.</p>	<p>Check the volume. Check if it's under the Do Not Disturb period.</p>
<p>Unable to add LEGEE to the App via Wi-Fi.</p>	<ul style="list-style-type: none"> <li>• Restart LEGEE and the App.</li> <li>• Check if the Wi-Fi signal is stable, and if LEGEE and your smartphone are under the same Wi-Fi network.</li> <li>• Check if the App needs an update.</li> <li>• Check if you have entered a wrong Wi-Fi password.</li> </ul>
<p>LEGEE is offline.</p>	<ul style="list-style-type: none"> <li>• Check if the Wi-Fi or Hotspot signal is stable.</li> <li>• If LEGEE has been moved to a different wireless network, please re-establish the connection between LEGEE and the App before use.</li> </ul>
<p>Can LEGEE work when offline?</p>	<p>LEGEE can work following the schedule queue even when it is offline, all the cleaning data will be stored in the device first, when it is connected again, the stored data will show up in the App.</p>
<p>Unable to save a default map.</p>	<ul style="list-style-type: none"> <li>• Check if LEGEE started from the charging station.</li> <li>• Check if LEGEE returned to the charging station without interruption.</li> <li>• Use the "Wall Following" function so LEGEE will only clean along the wall and complete map-drawing in a shorter period of time.</li> <li>• Make sure LEGEE has not been moved or lifted off the floor during cleaning.</li> </ul>

**If any problems occur and this manual cannot provide the solution you need, please contact a local retailer or authorized dealer.**



HOBOT Technology Inc.

[www.hobot.com.tw](http://www.hobot.com.tw)