



2-3 hours







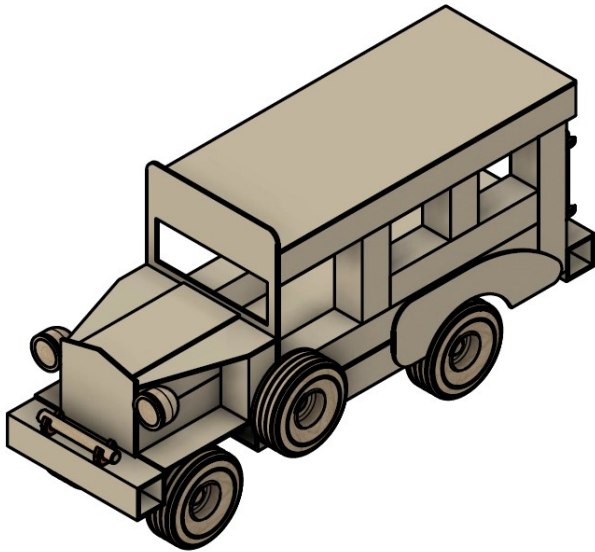

Grit required



Ages 8+

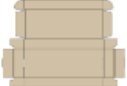

Part	Part name	Qty
	Cori Beam	9
	Axle Bracket	4
	Bracket	6
	Wheel	5
	Axle	2
	Bar	3
	Headlight	2
	Jeepney box	1

1

Cut and fold 25 pieces of Cori beams to the dimensions shown in the table to the right.

To optimize usage, you will want to start with the longest beams first and work your way towards the smaller beams using the leftover pieces along the way.

Cori beam length	Quantity
10 inch	2
8 inch	2
7 inch	2
4 inch	4
3.5 inch	4
3 inch	4
2 inch	3
1.5 inch	2
1.25 inch	2

## 2

Unfold the packaging box and use the templates at the end of the instructions to cut out the nine shaded Jeepney parts.

### CUTTING TIP!

Place template on cardboard and use a sharp pencil to transfer shape to cardboard by dotting along each line piercing through the paper.

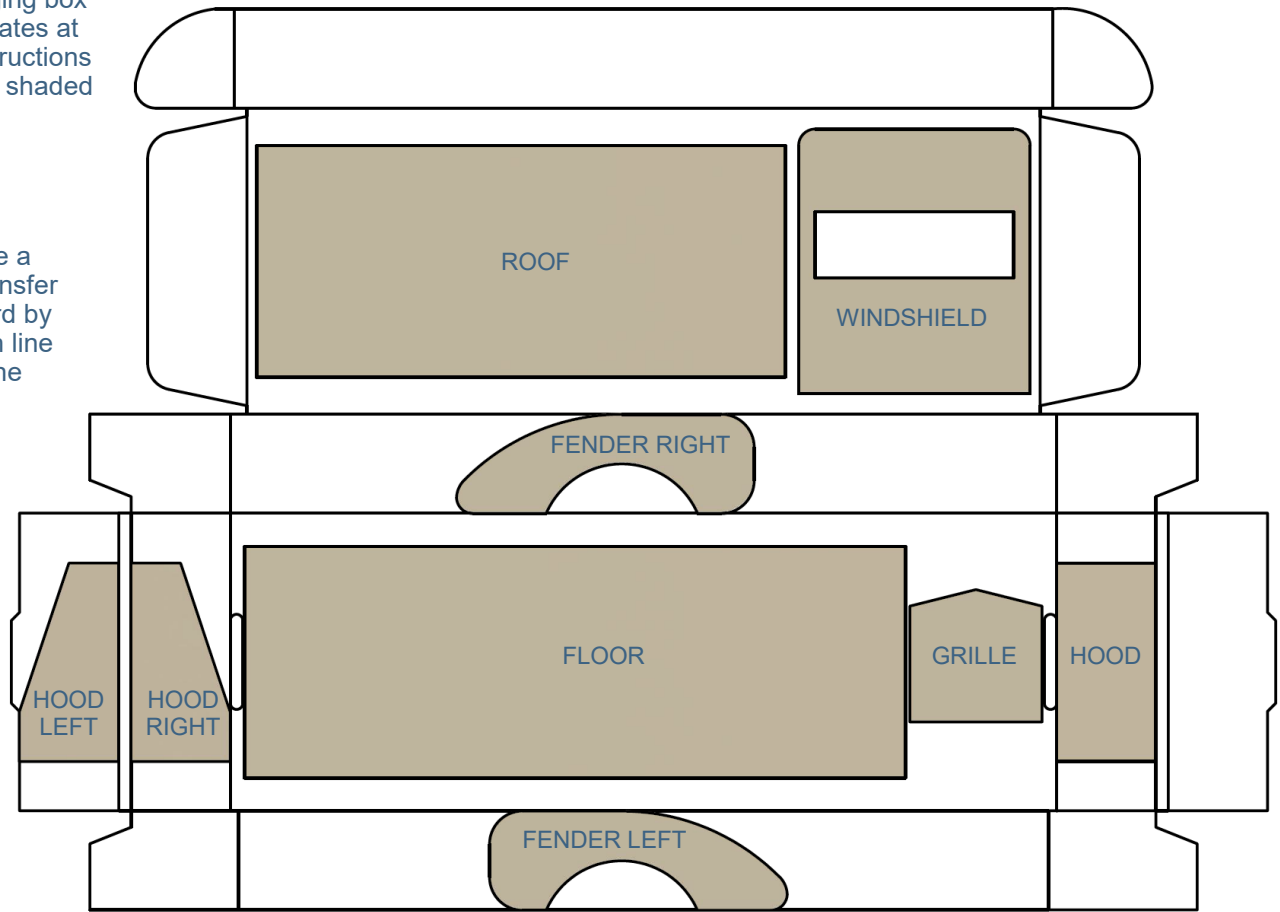

## 3

Start with the largest sheet from step 2 for the floor of the Jeepney.

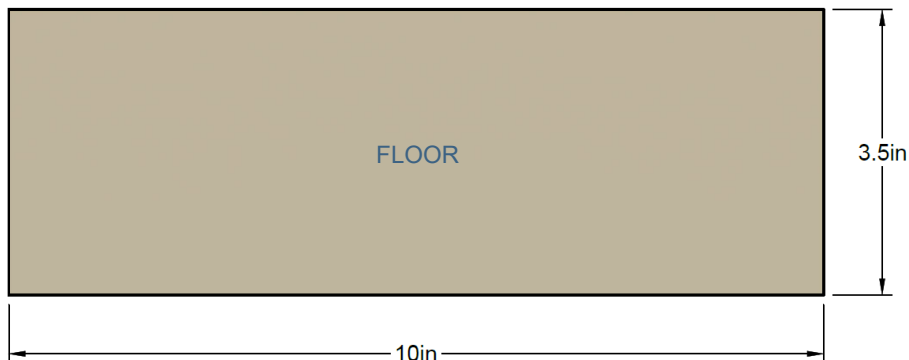
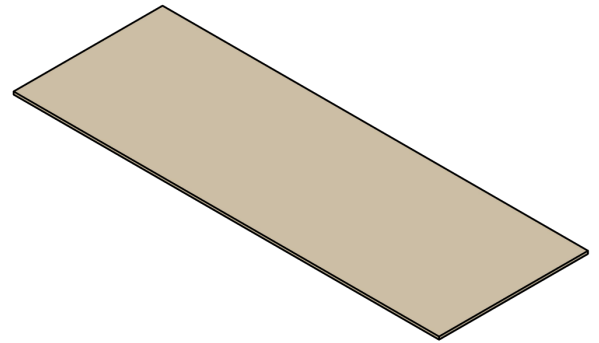

- 4 Glue two 10in and two 4in Cori beams to the floor from step 1 according to the illustration below. This will form the lower frame of the Jeepney. Apply glue along all adjoining surfaces to ensure a strong foundation.

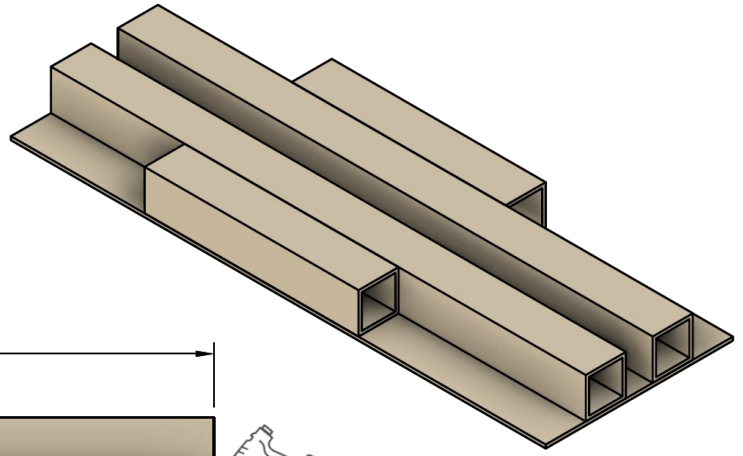
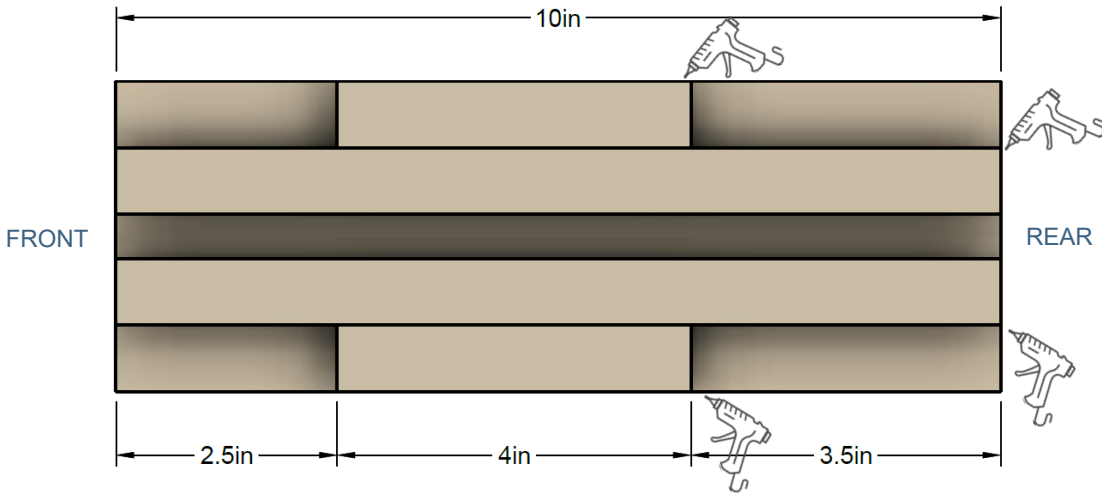

- 5 Flip the assembly from step 2 around. Note the front vs. rear of the vehicle. Add two 3in and two 1.5in beams in the configuration shown. Glue in place.

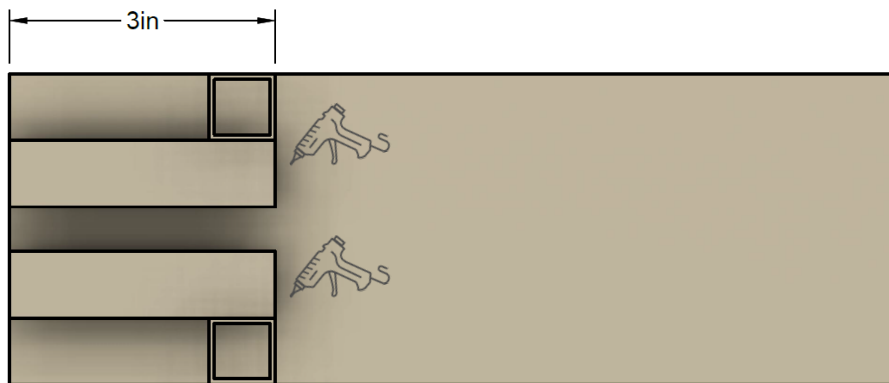

FRONT

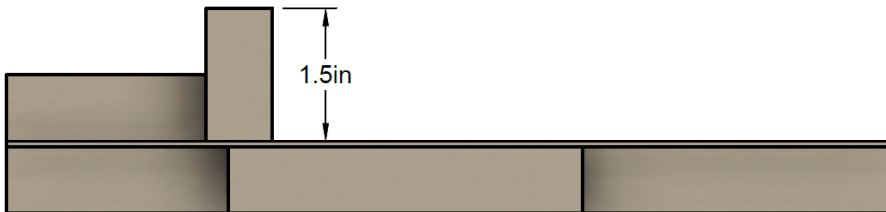
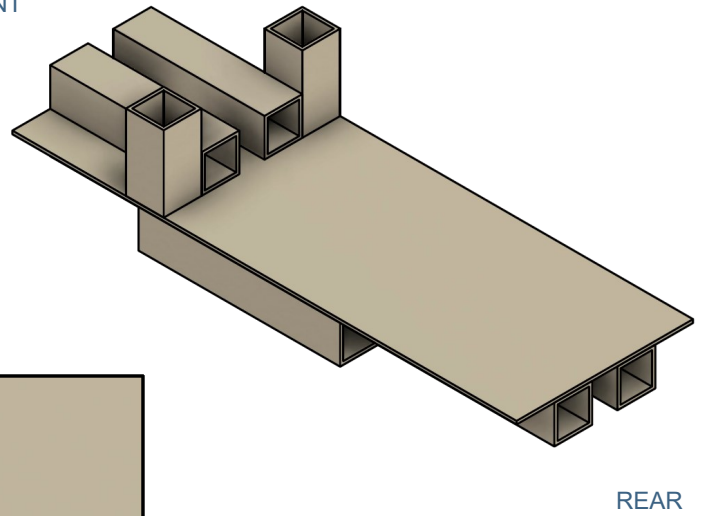

6

Add two more 3in beams for the engine compartment.

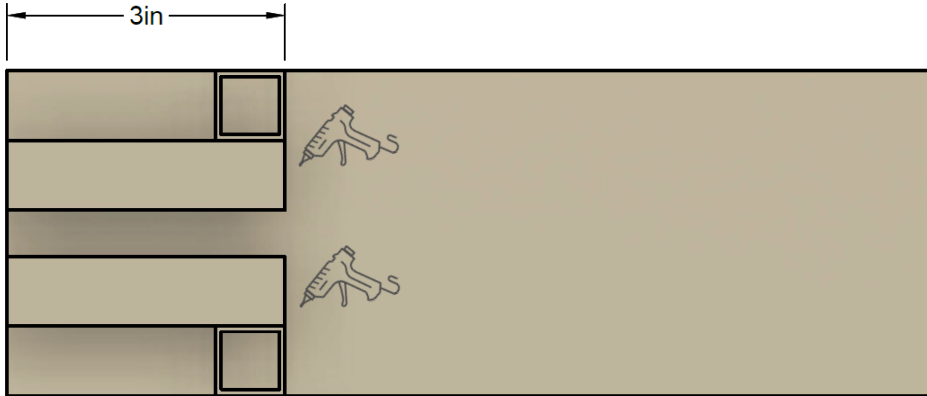
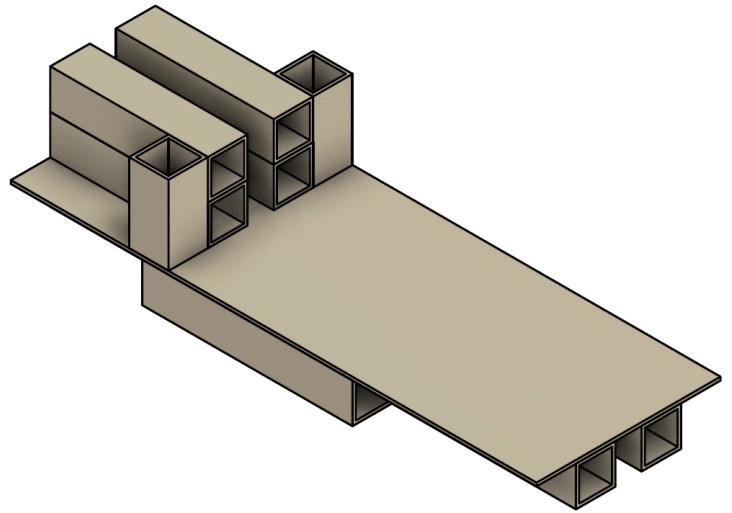

7

Cut out the windshield following the dimensions below or use the template at the end of the instructions. For less cutting, you may choose to simply draw in the window section.

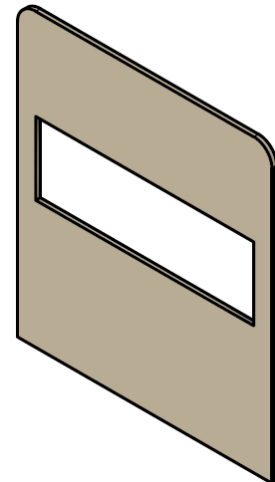
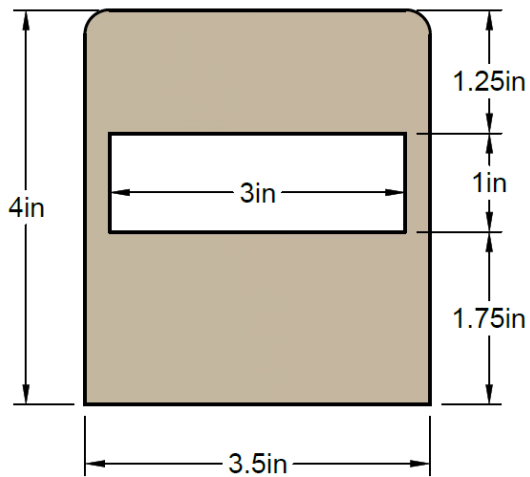

8

Glue the windshield in place

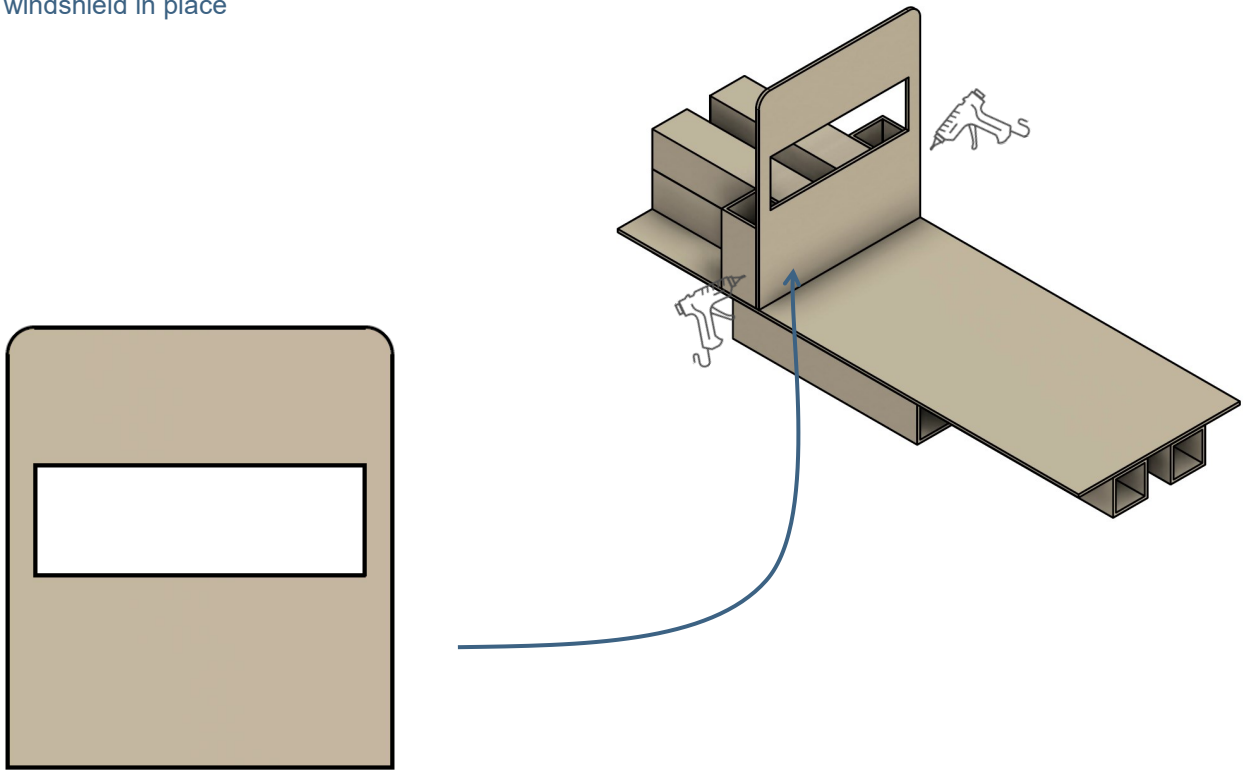

9

Start the main chassis by adding the two 7in beams shown below. These will slightly overhang the rear of the Jeepney floor.

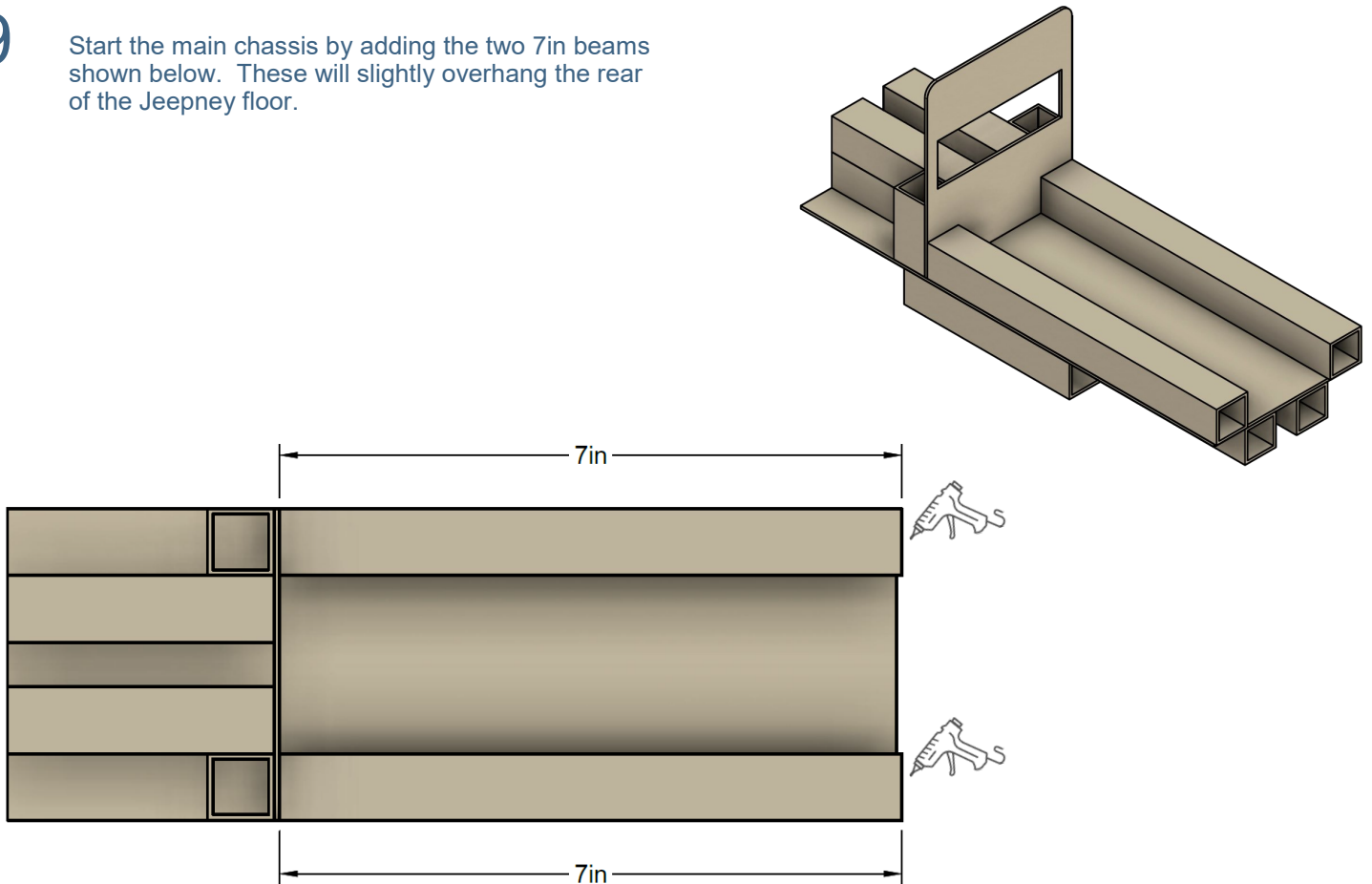

10 Add two more 4in horizontal beams for the chassis. These should be flush with the beams from step 9.

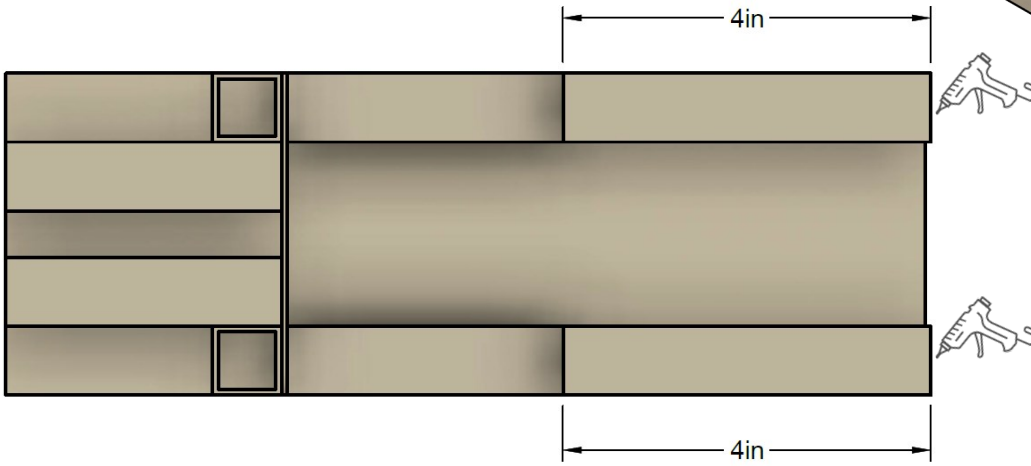
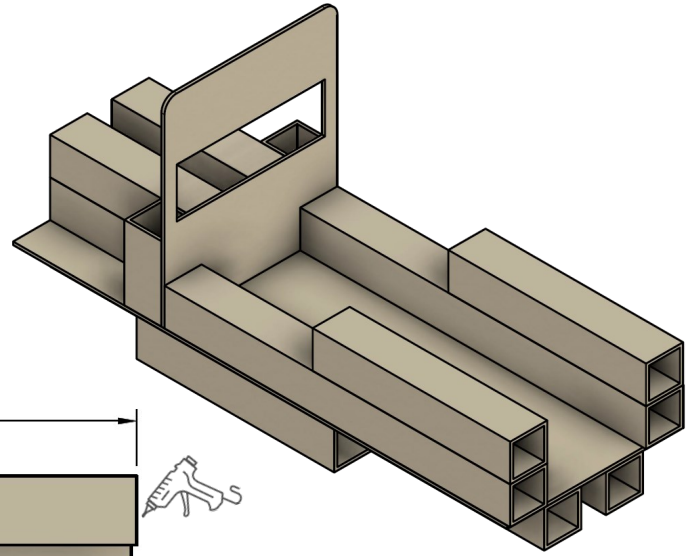

11 Add two 2in and two 1.25in vertical beams as shown below for roof pillars.

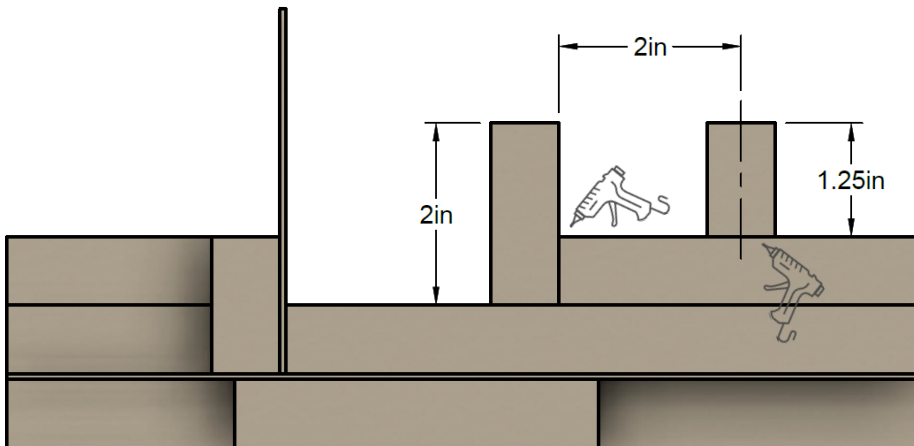
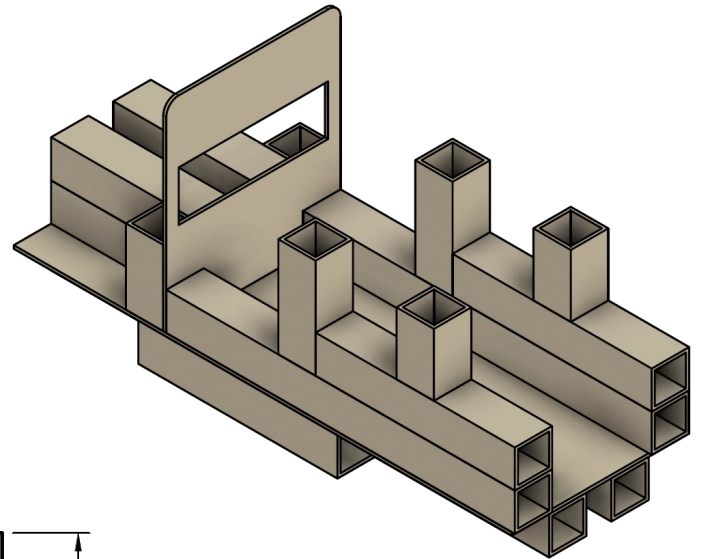

**12** Take the Jeepney roof that was cut out in step 2.

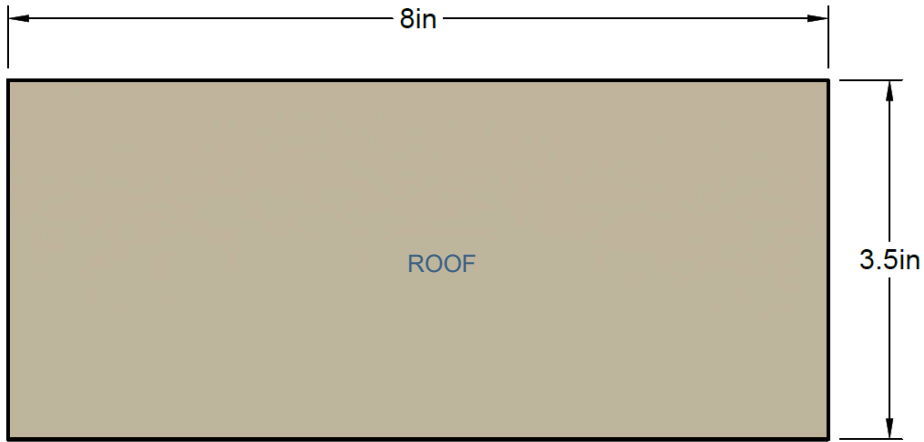
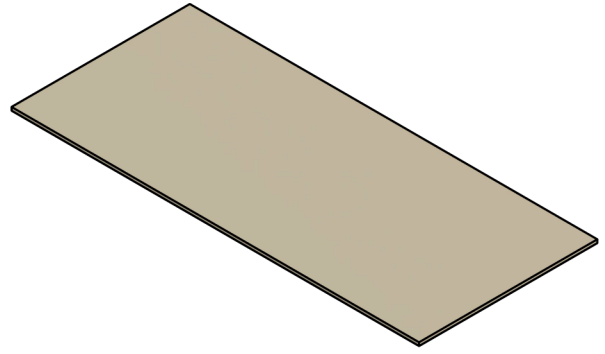

**13** Add two 8in Cori beams along the edge of the roof from step 12.

Roof shown upside down.

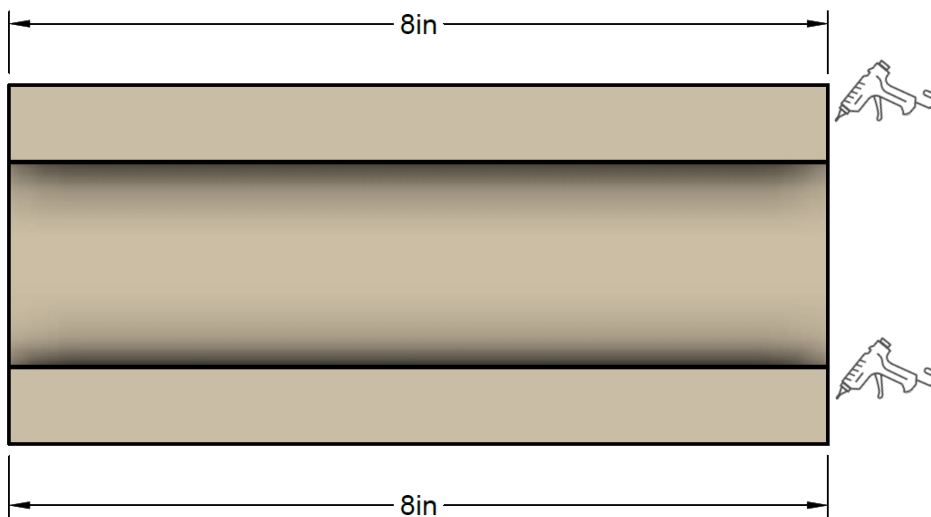
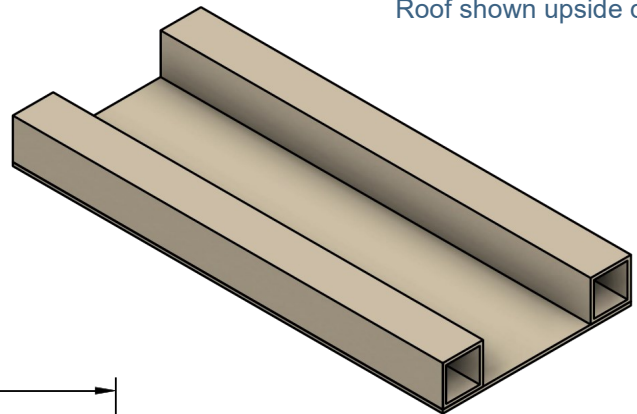

- 14 Flip the roof from step 13 over, and glue to the windshield and roof pillars from the previous steps.

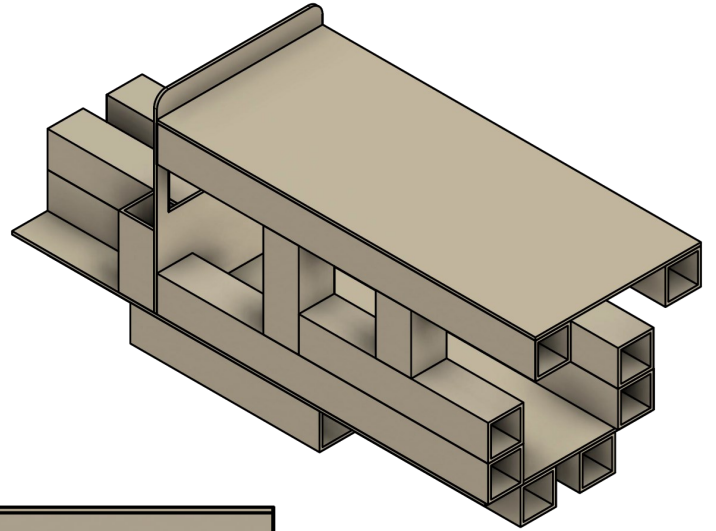
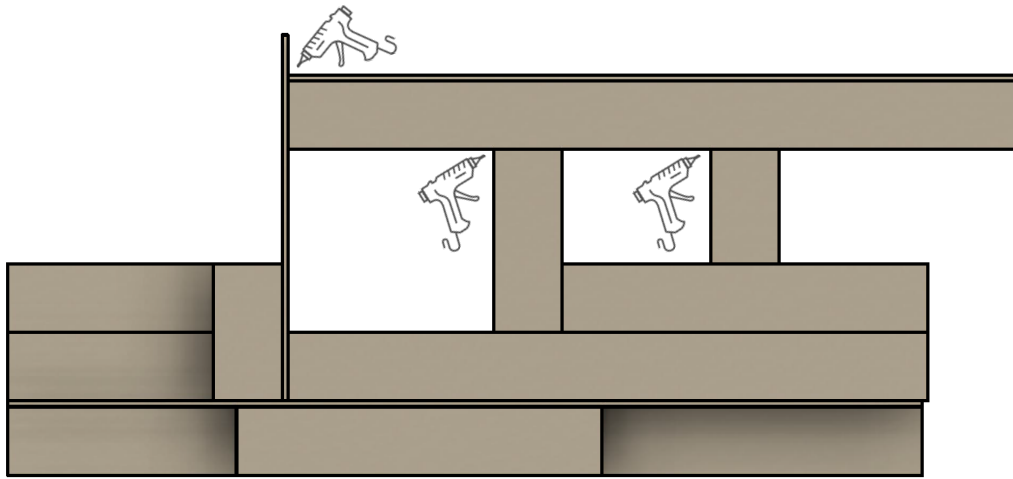

- 15 Add a 2 inch beam for a step at the rear of the Jeepney.

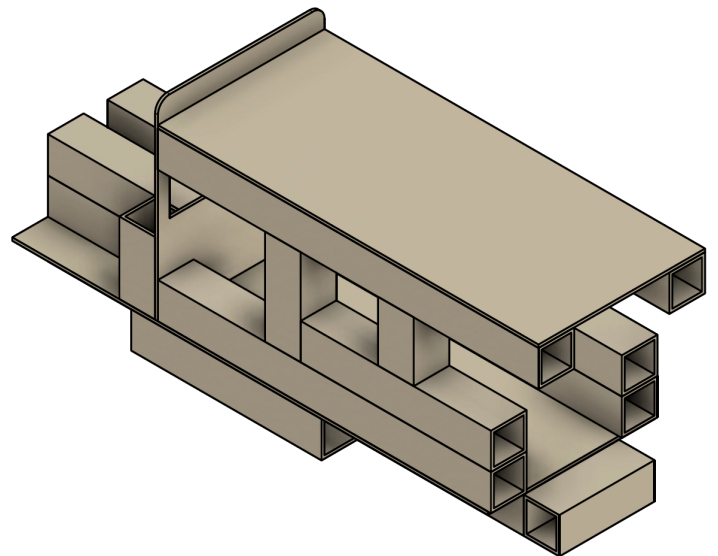
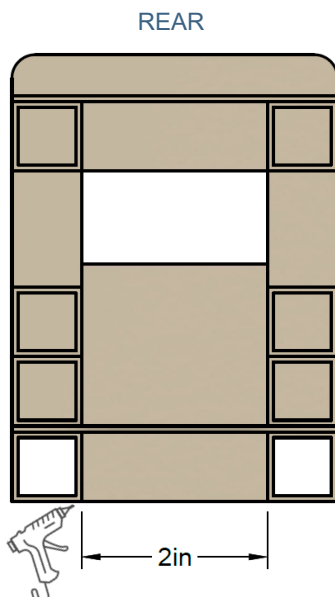



16 Finish off the roof support by adding two more 3.5in vertical pillar beams at the back of the Jeepney.

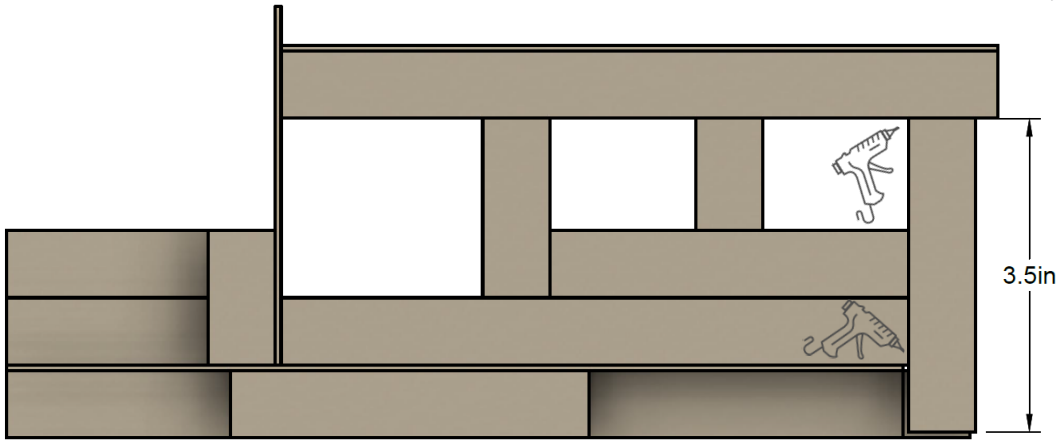
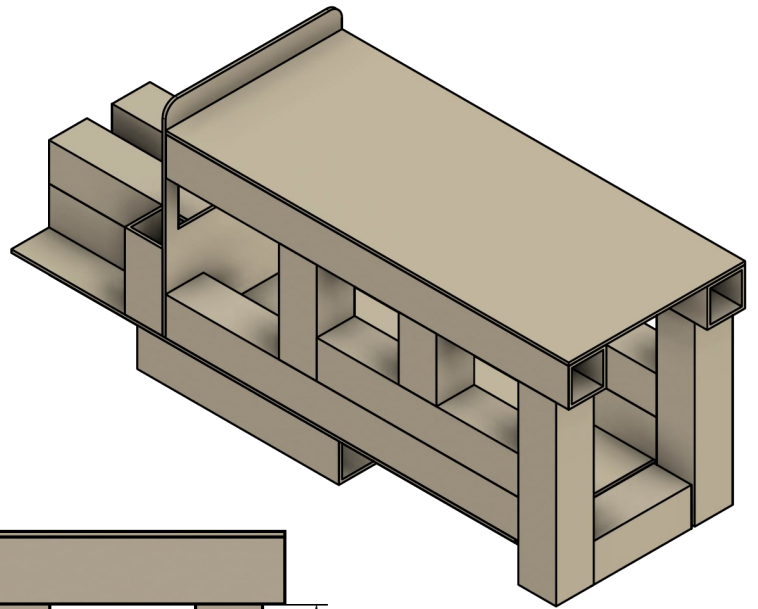

17 Add two more 3.5in beams for the front and rear bumpers.

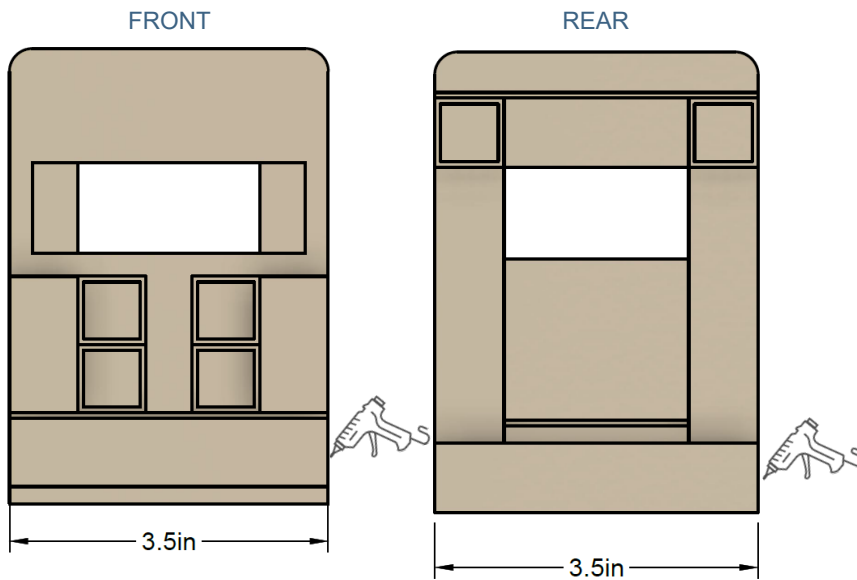
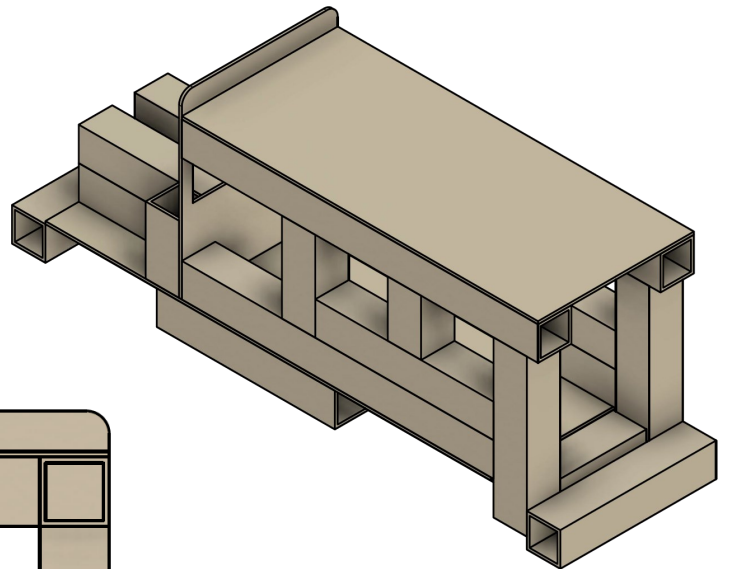

18 Take the left and right hood pieces from step 2.

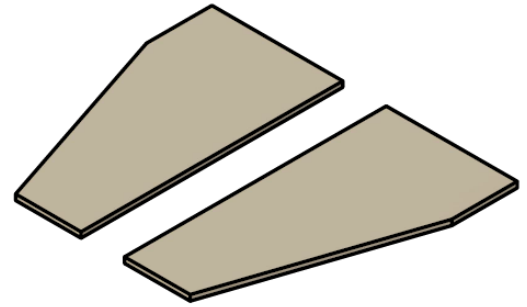
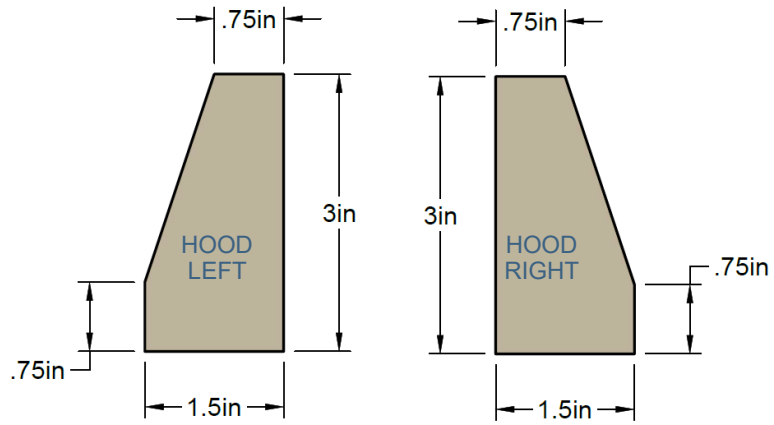

19 Glue in place.

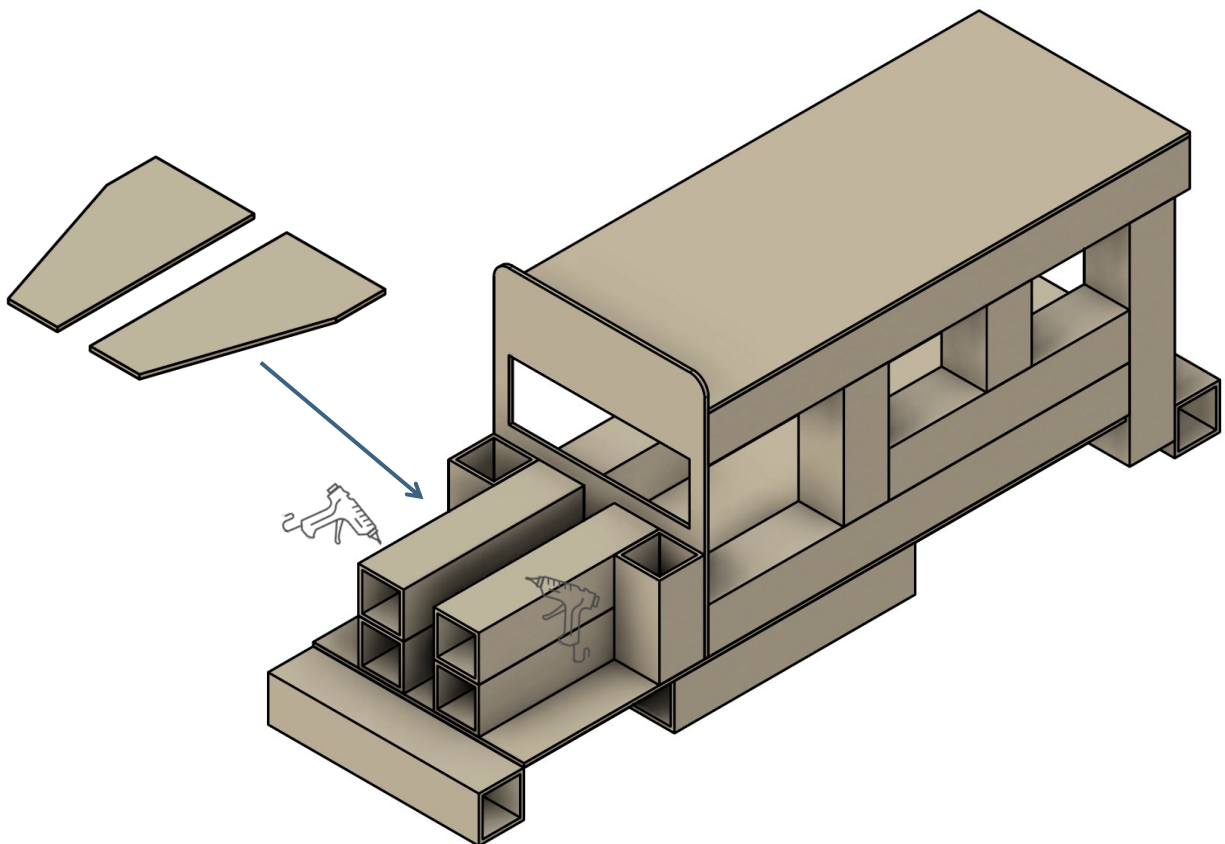

# 20

Add hood and grille from step 2. Glue in place.

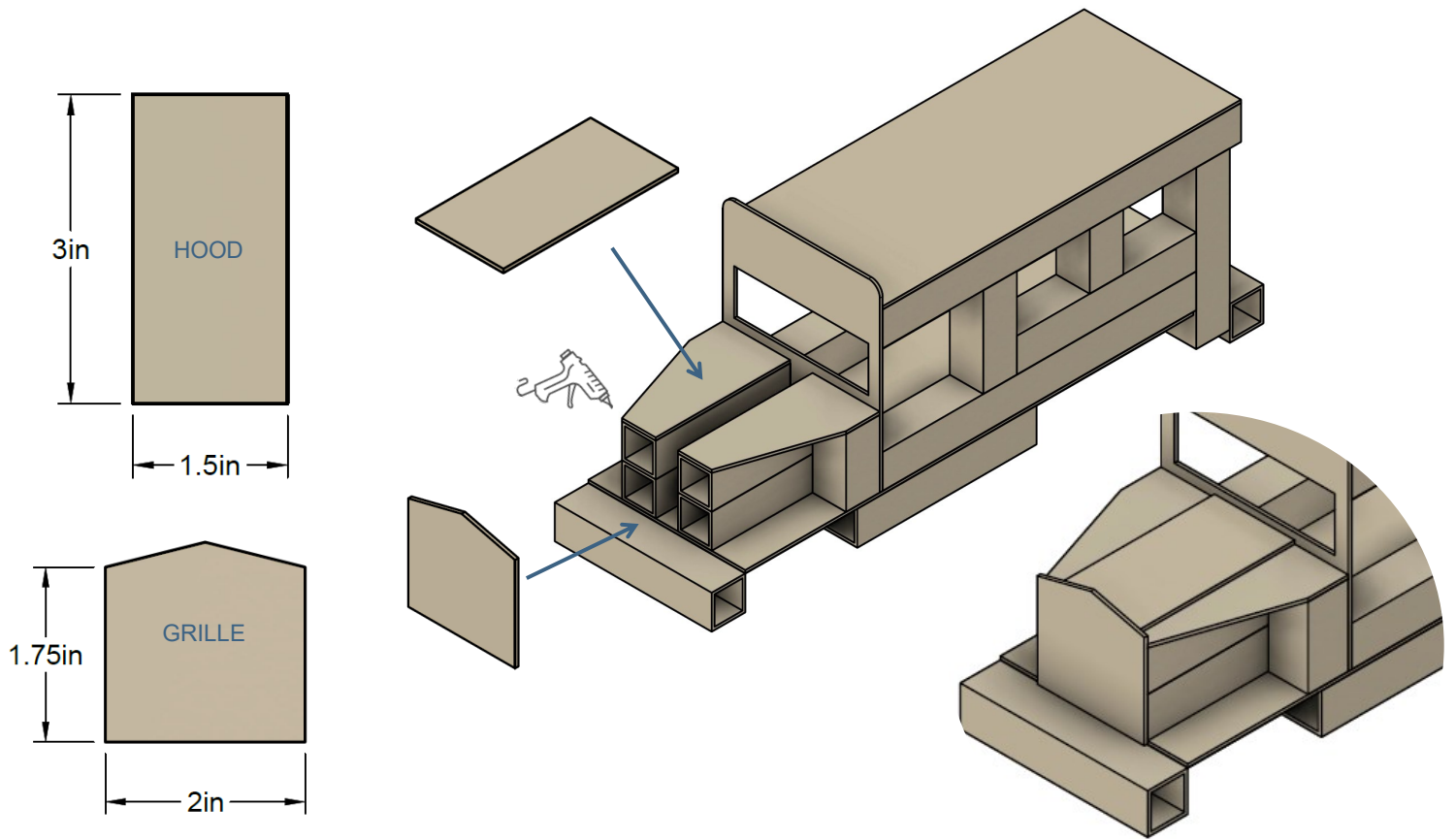

# 21

Glue down the four snap in brackets in the locations shown below. Notice the orientation of each bracket.

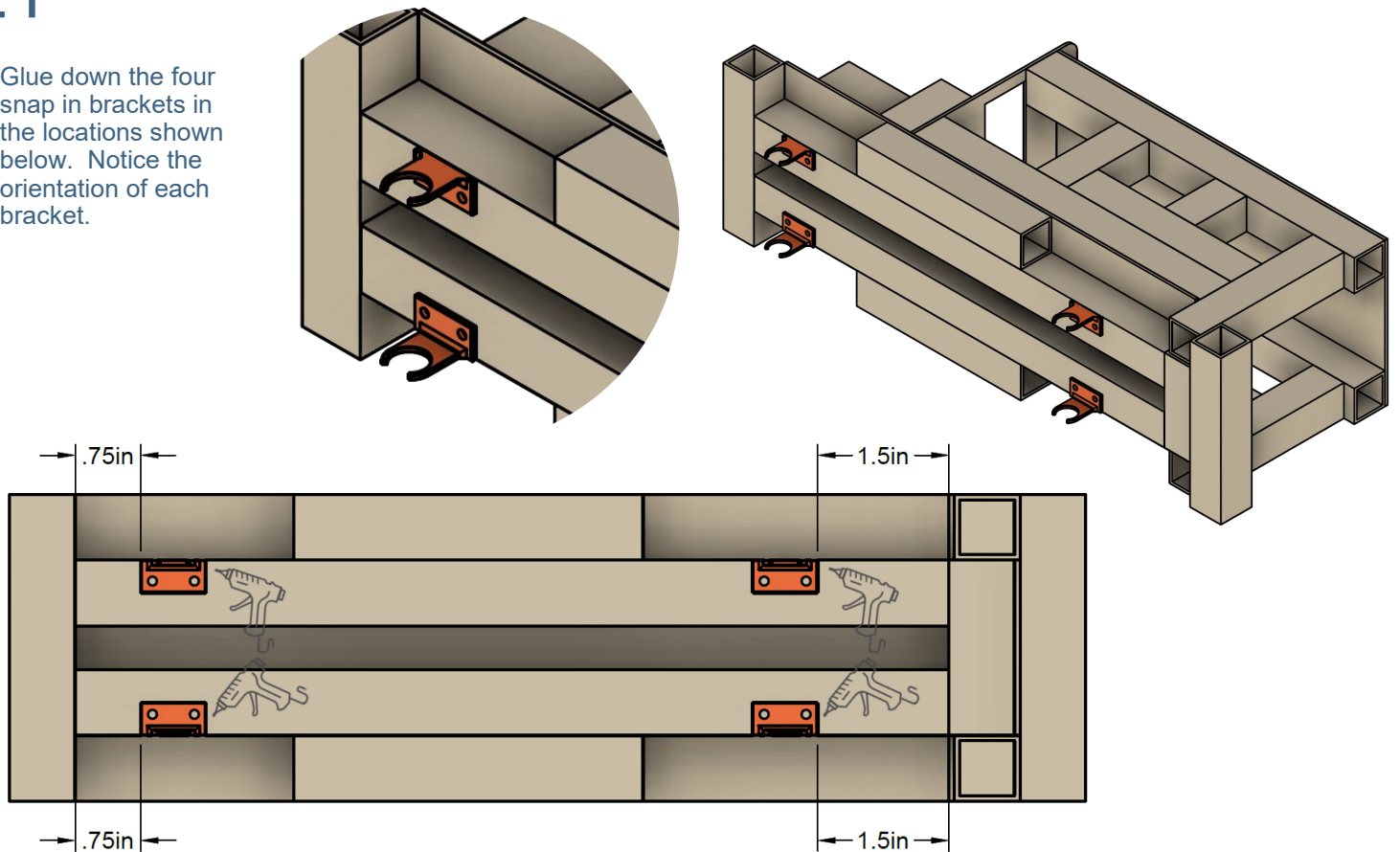

**22** Assemble the wheels by pushing them onto the axles leaving at least a 2" gap between the wheels. You will need two of these assemblies. Apply glue if needed.

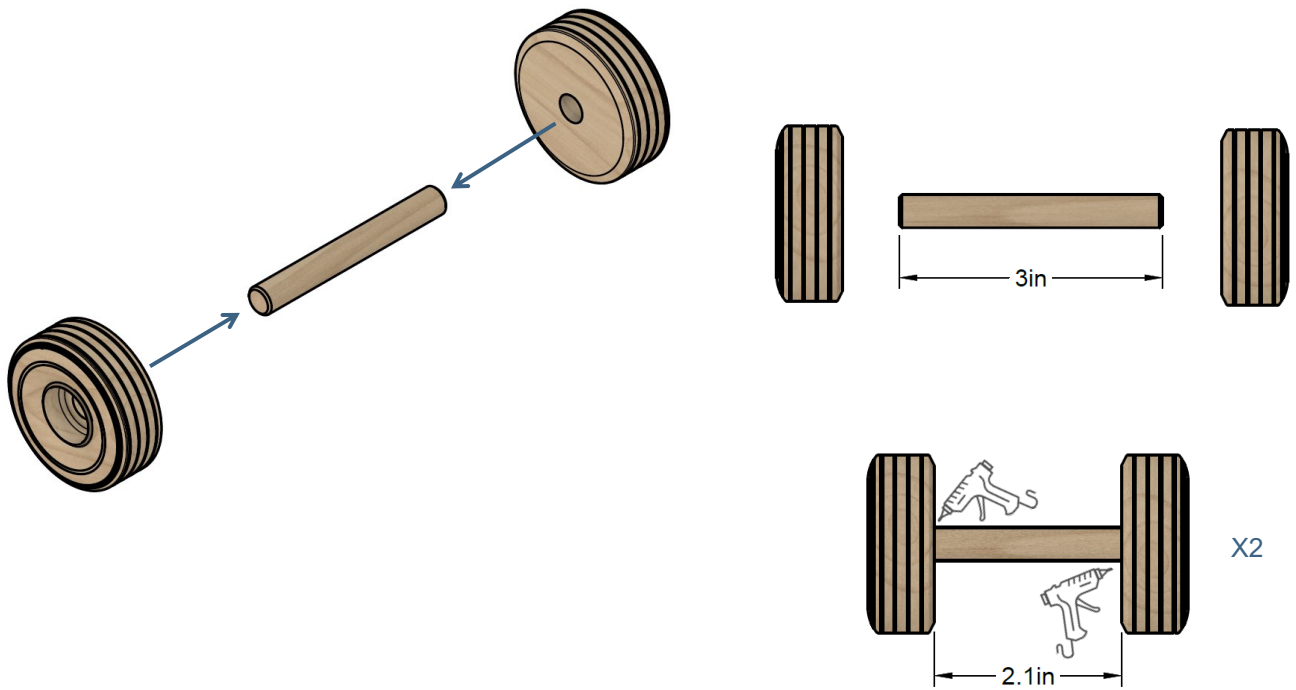

**23** Push each wheel assembly in place. It may help to rotate wheels slightly as they snap into the brackets.

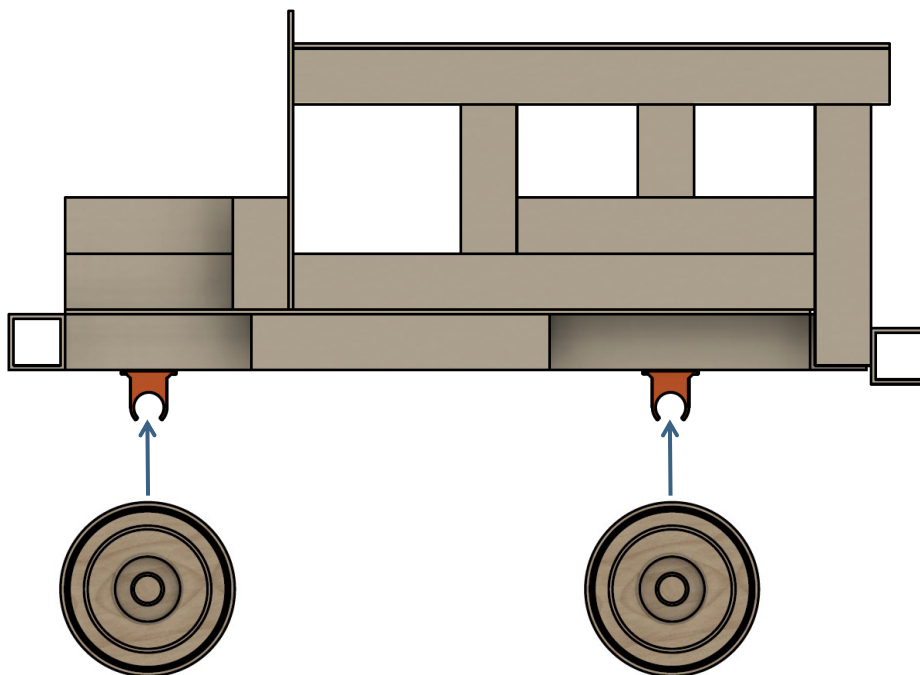

## 24 Add spare wheel (optional).

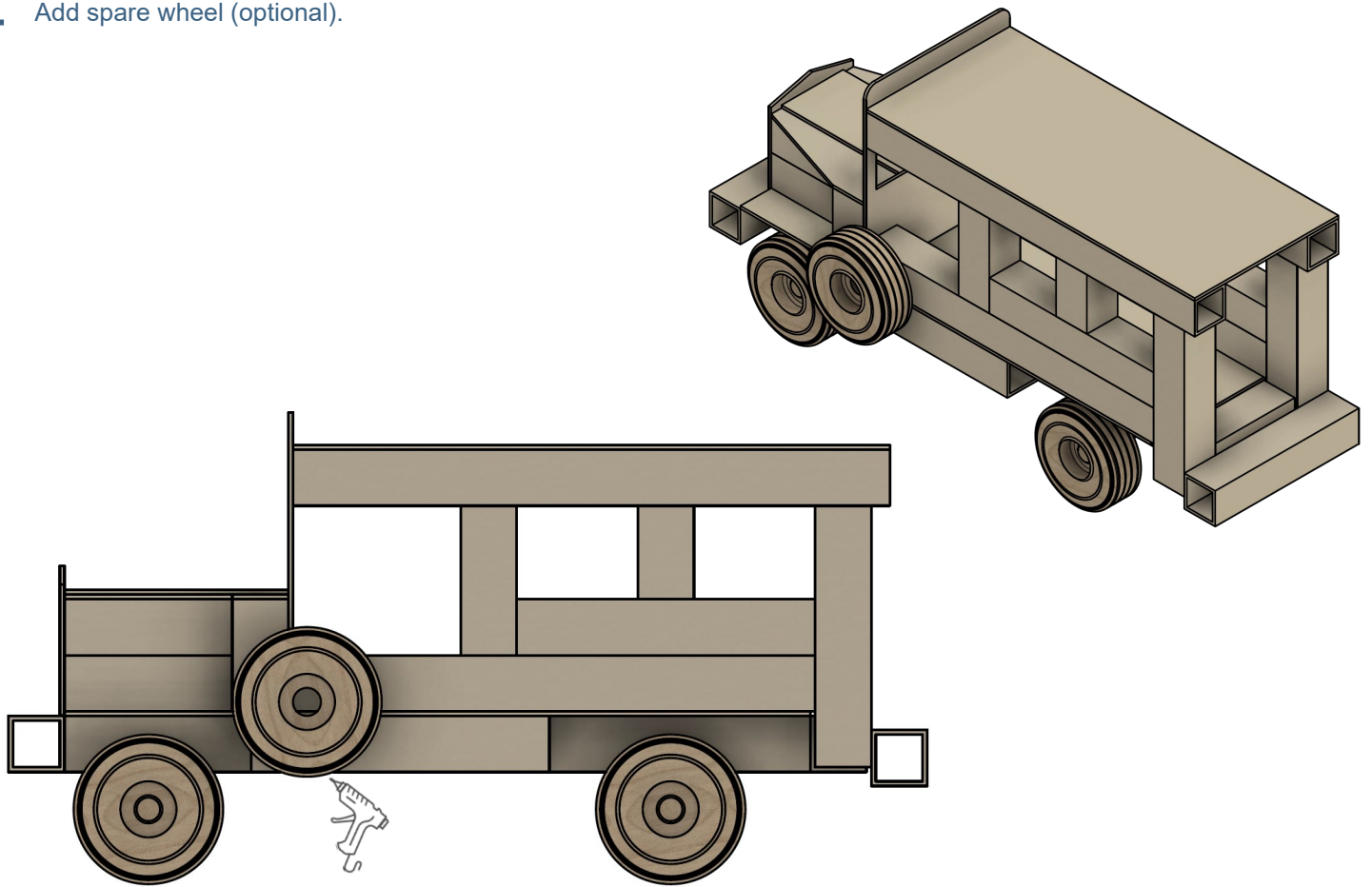

## 25 Add the grill guard (optional).

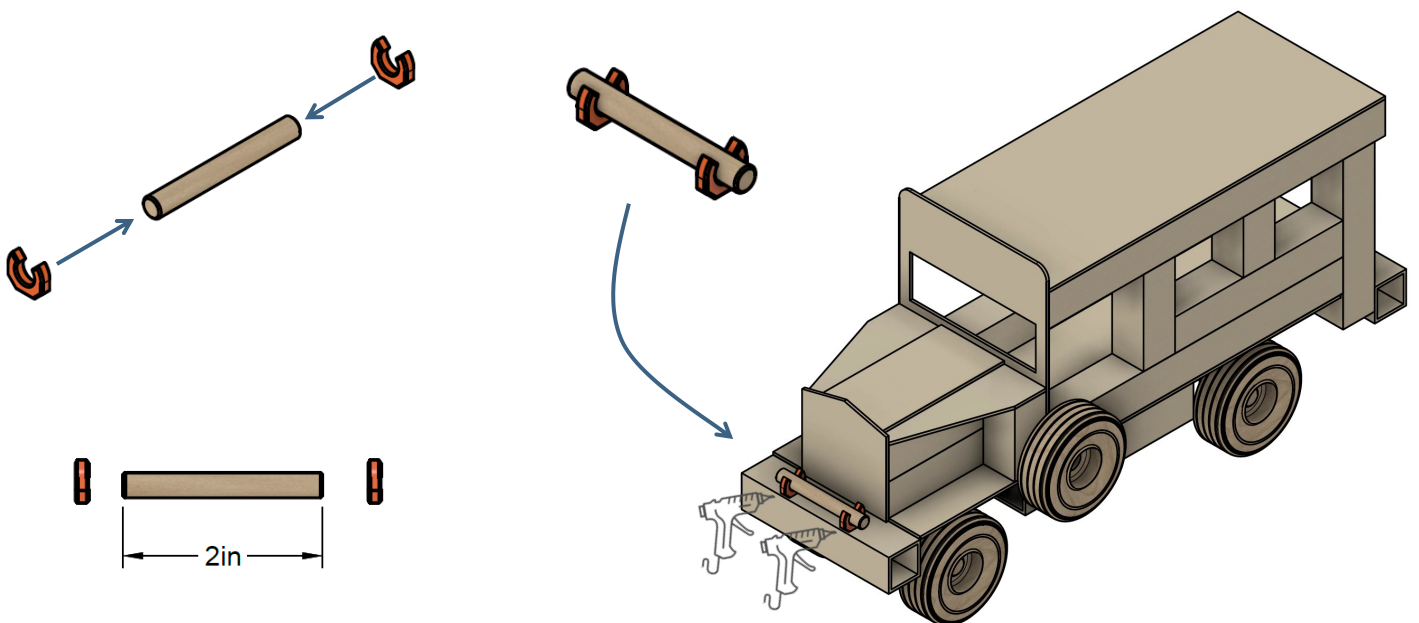

26 Add two handle bars to the rear (optional).

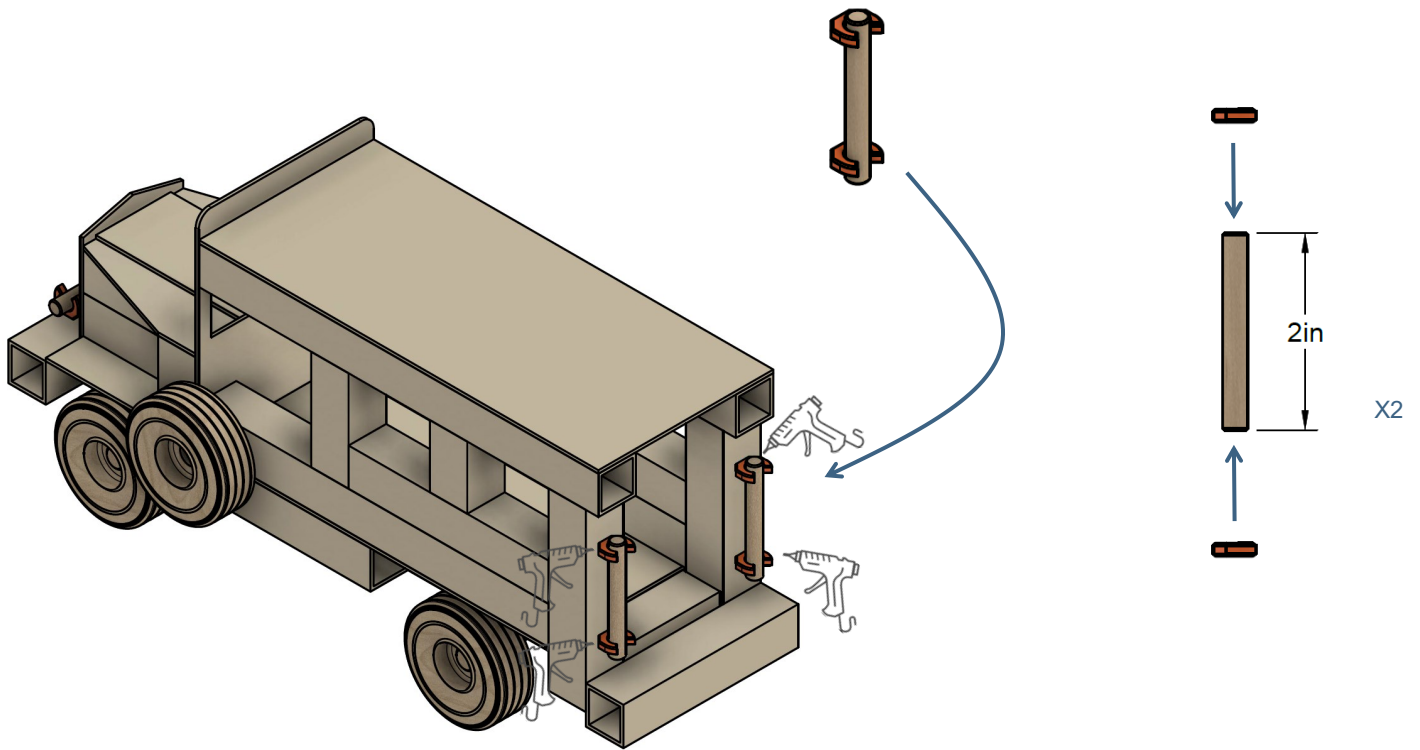

27 Add the headlights by gluing them onto the side of the grill (optional).

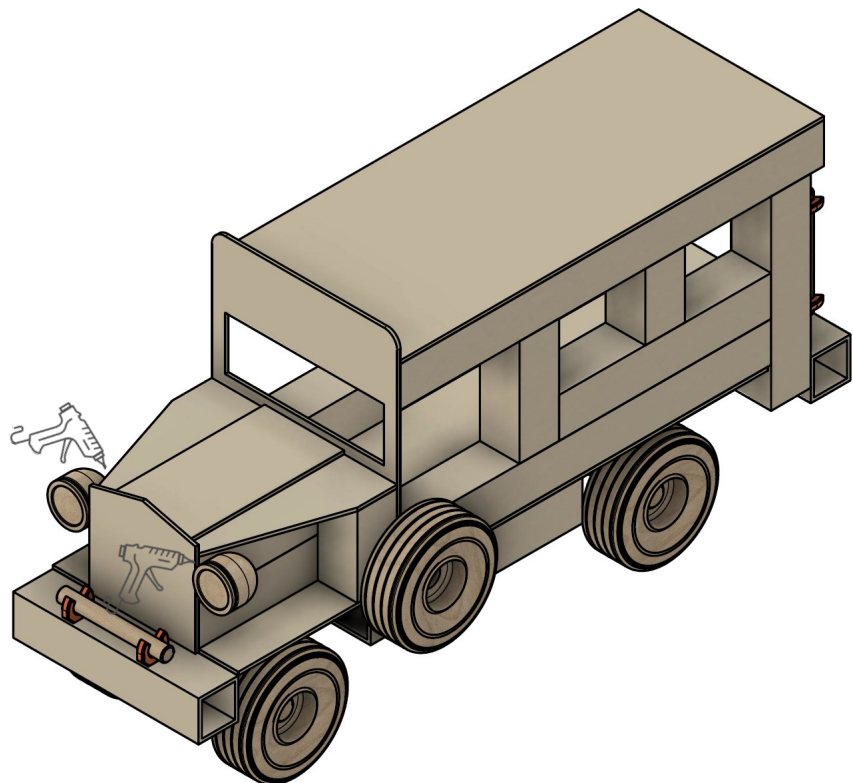

# 28

Add the two rear fenders from step 2 (optional).

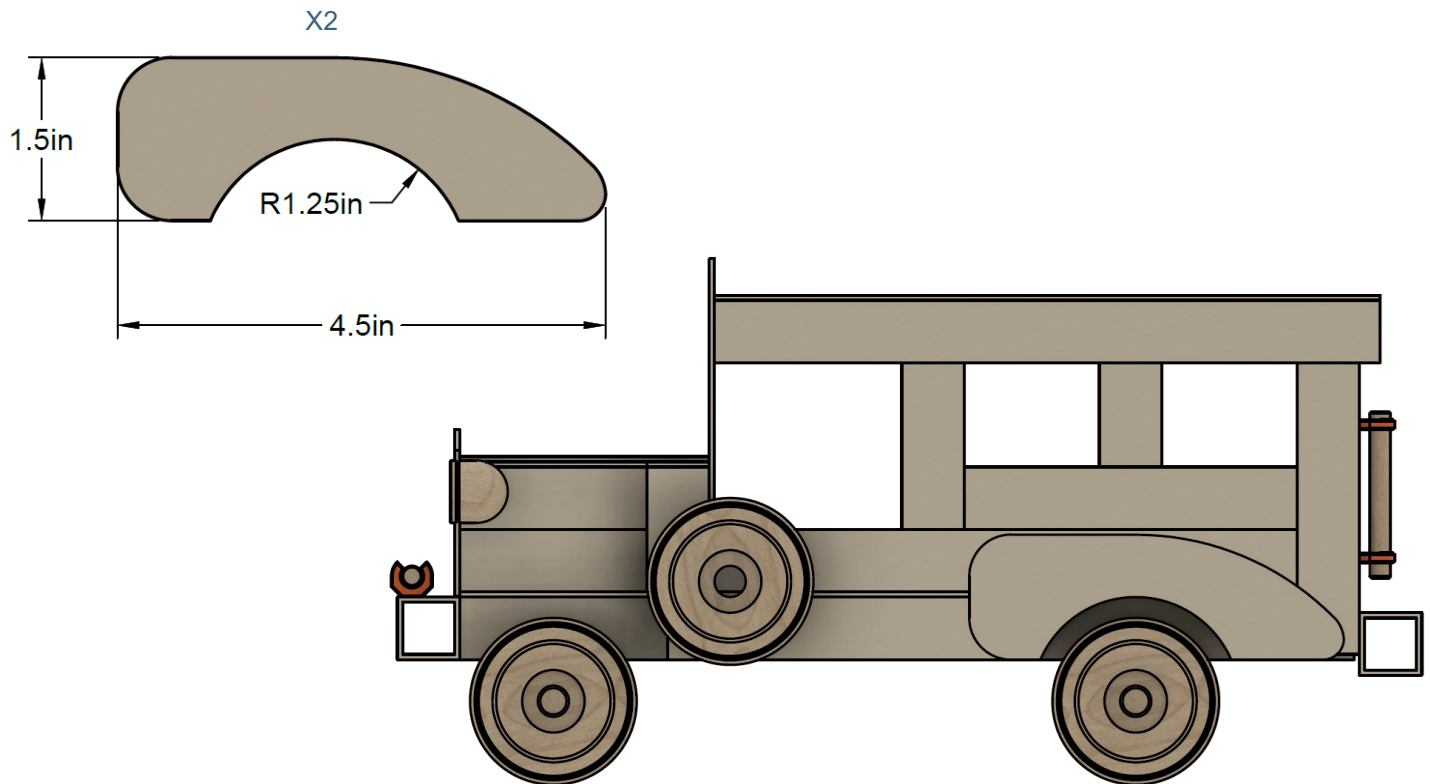

# 29

Your Jeepney is now ready for the most important part—art! Use whatever art supplies you have available to make the Jeepney truly unique. Unleash your creativity!

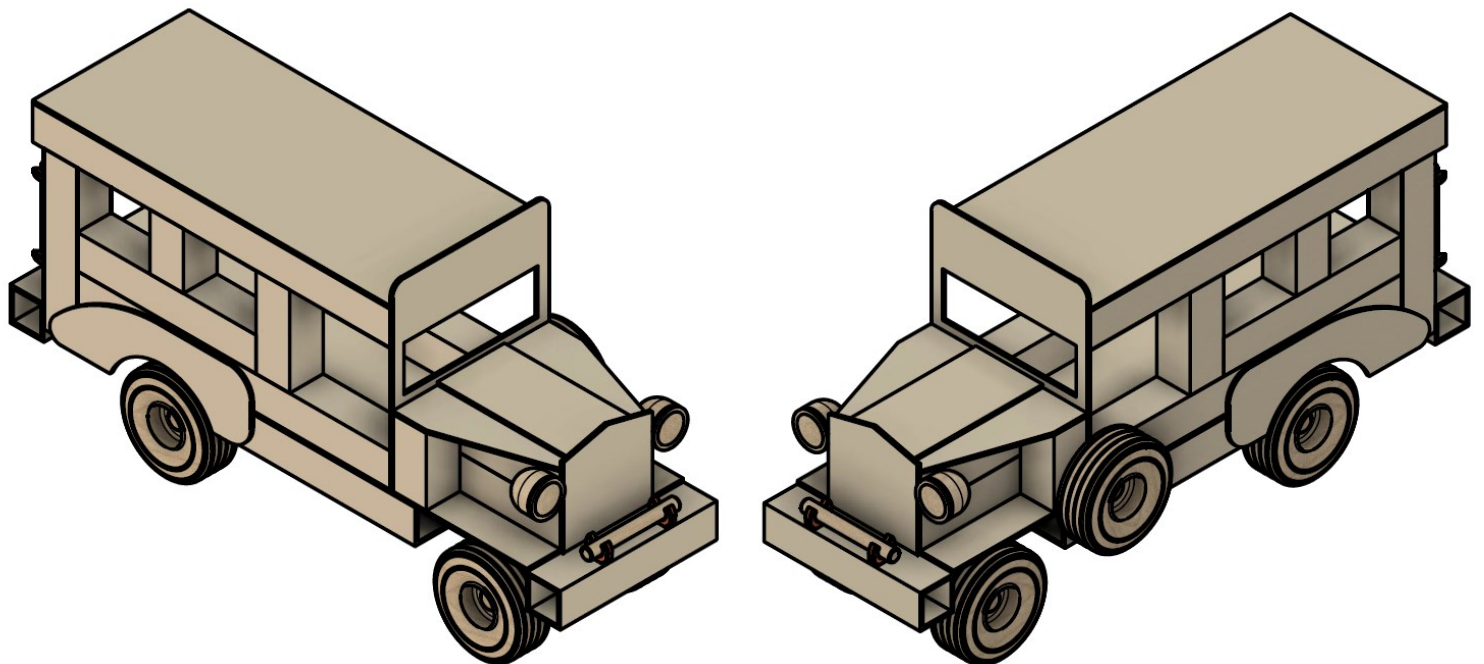

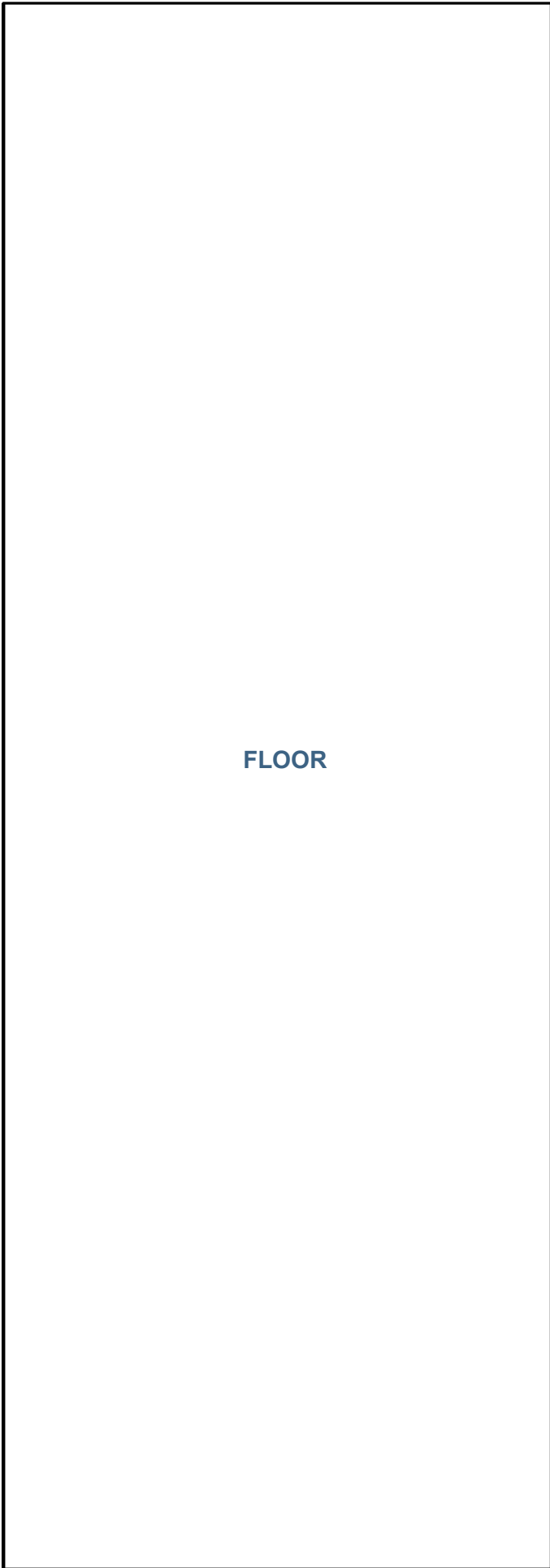

**FLOOR**

TEMPLATES—Use with unfolded Jeepney box (Step 2).

Place template on cardboard and use a sharp pencil to transfer shape to cardboard by dotting along each line piercing through the paper.

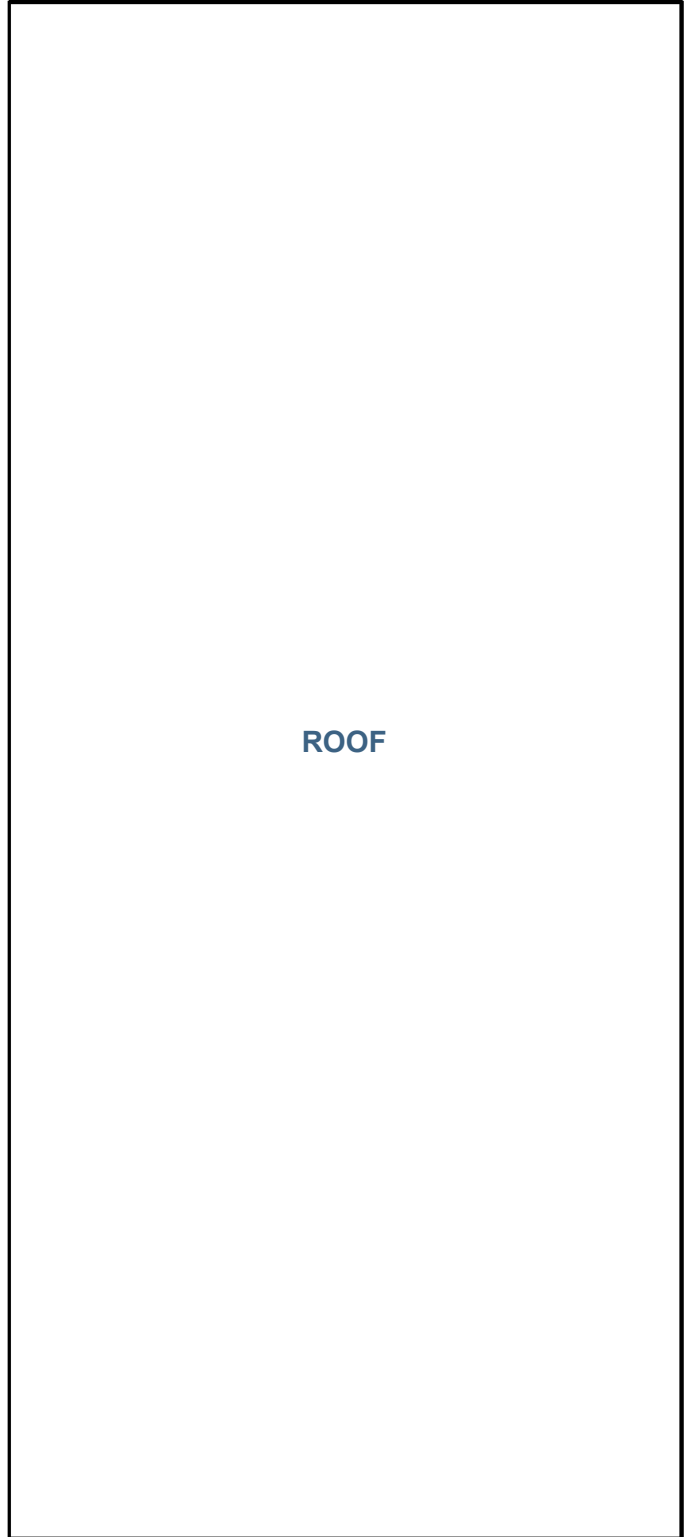

**ROOF**



