

Step stool

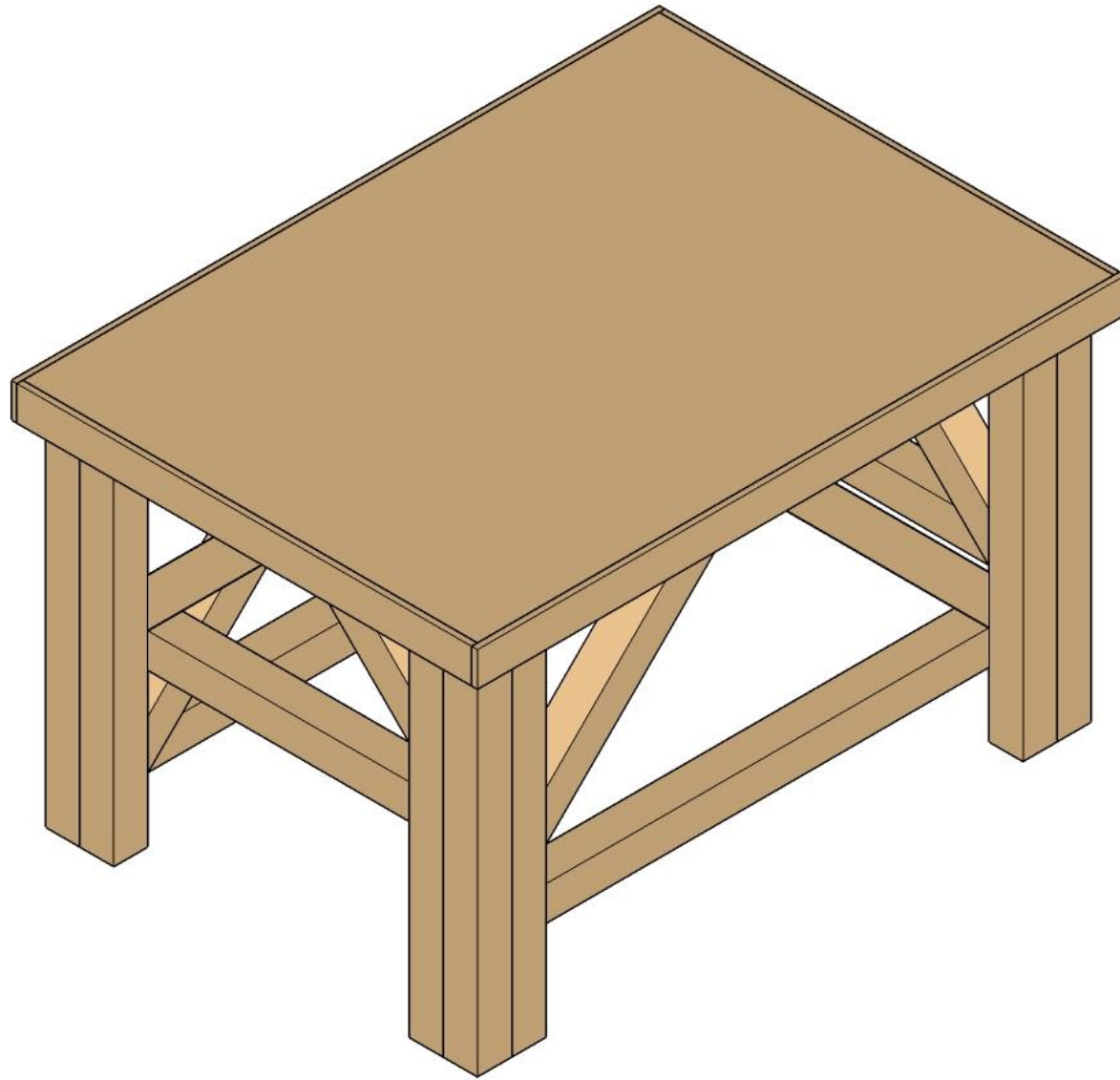

Step
1

Cut and glue five Cori Beams according to the drawing below.

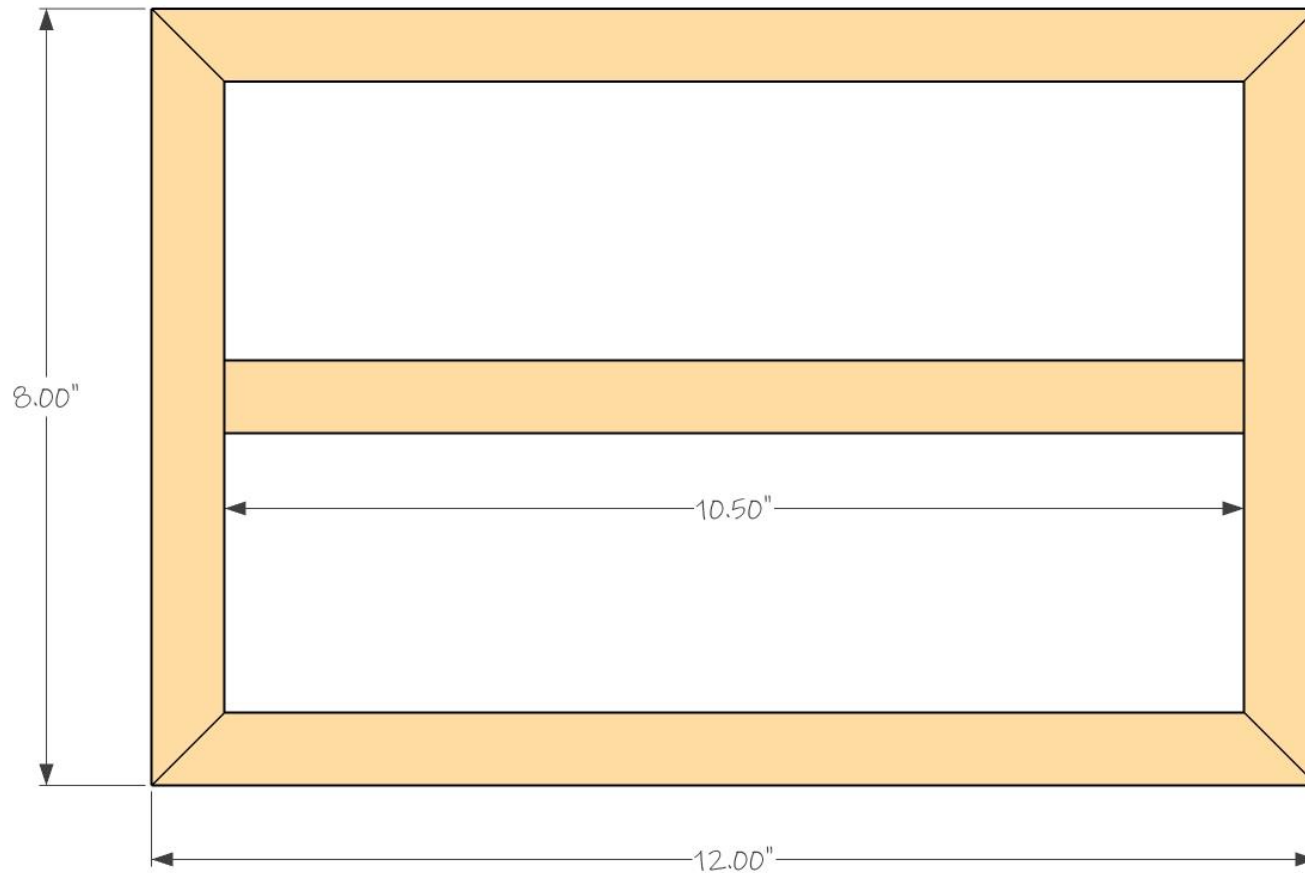
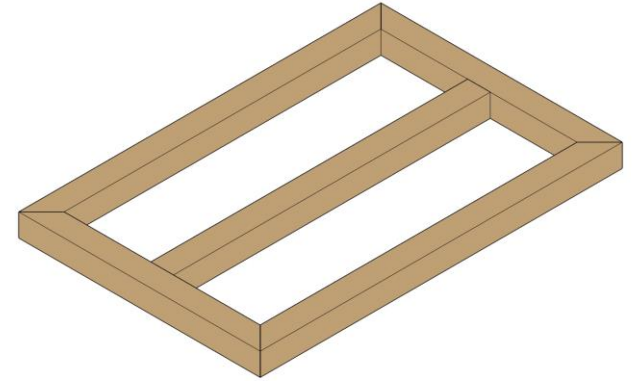

Step
2

Use twelve Cori beams of equal lengths for the legs.

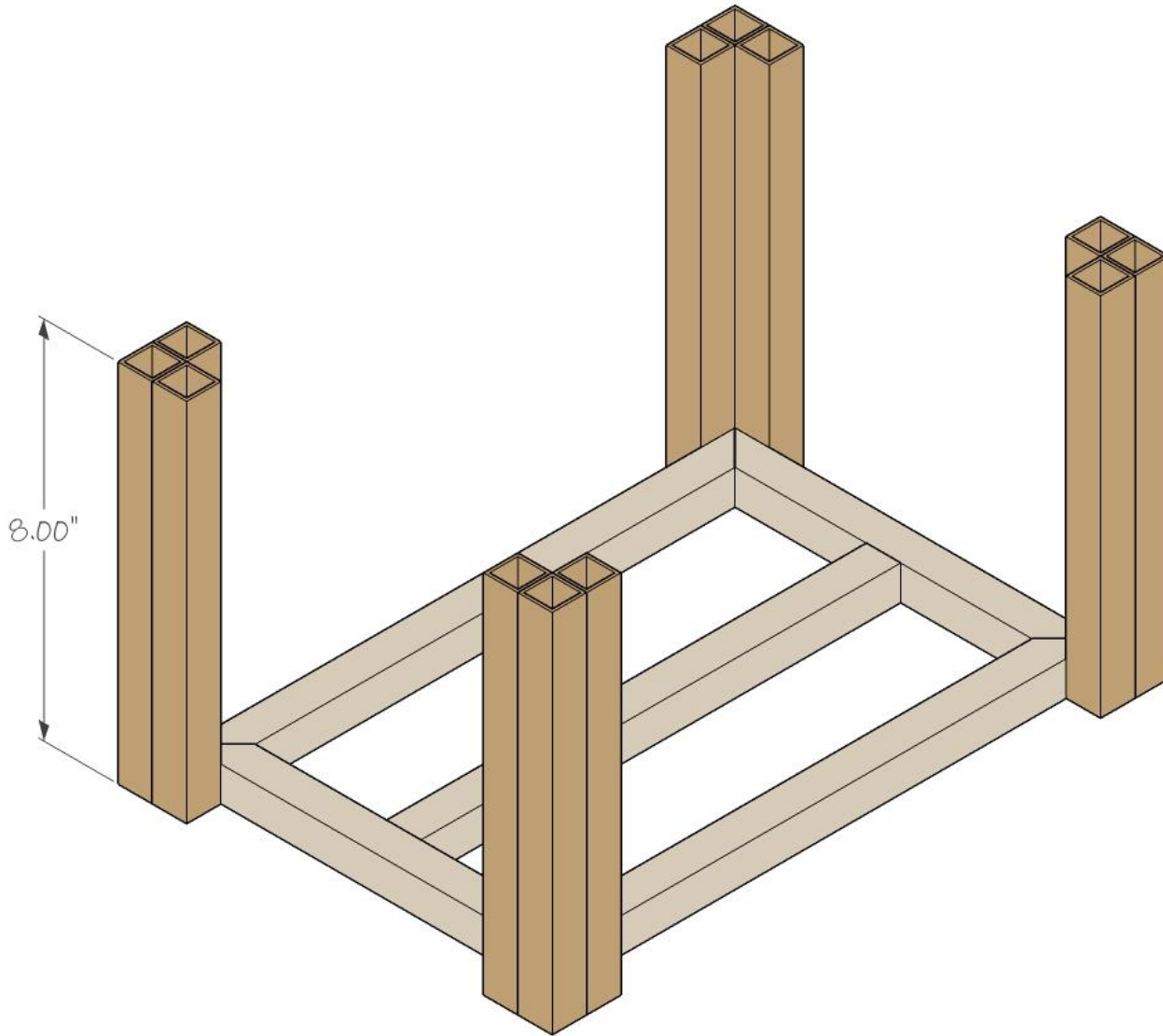

Step
3

Cut and glue diagonal support structures on the short end.

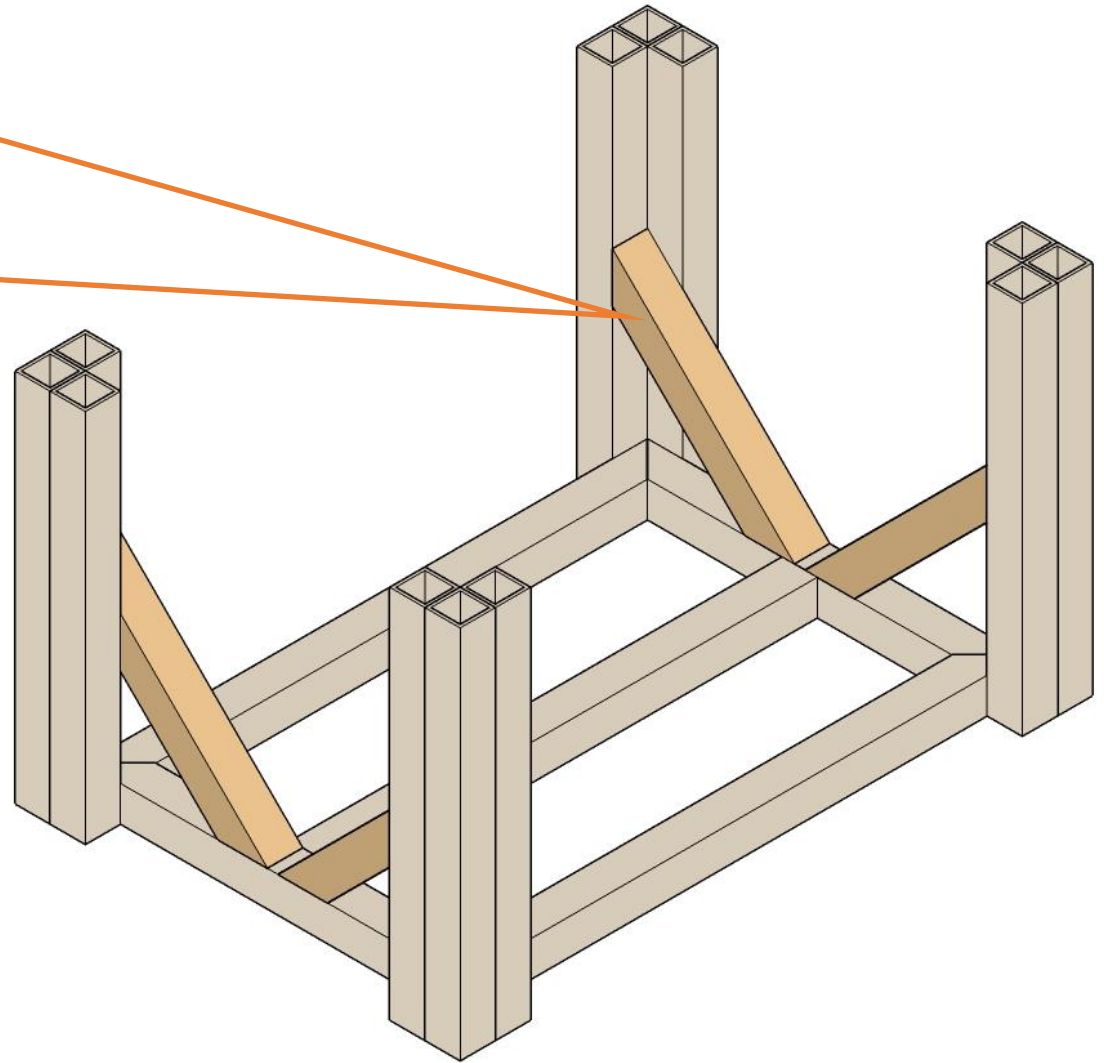
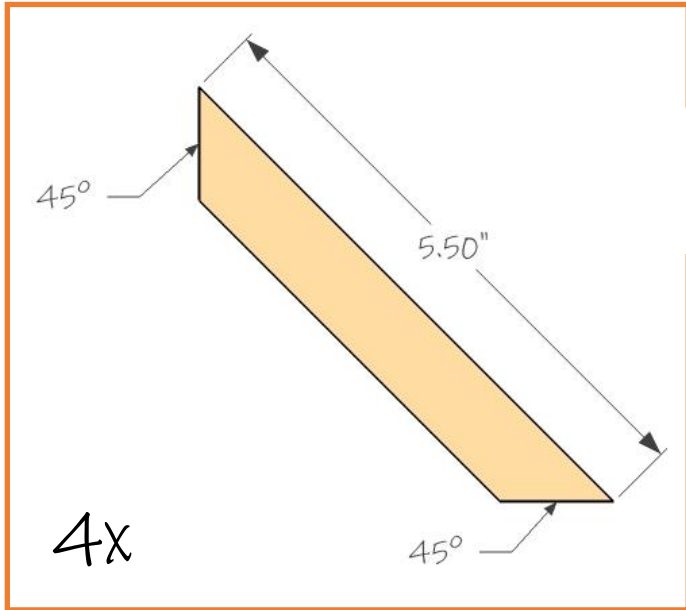

Step
4

Cut and glue cross bar members on the short end.

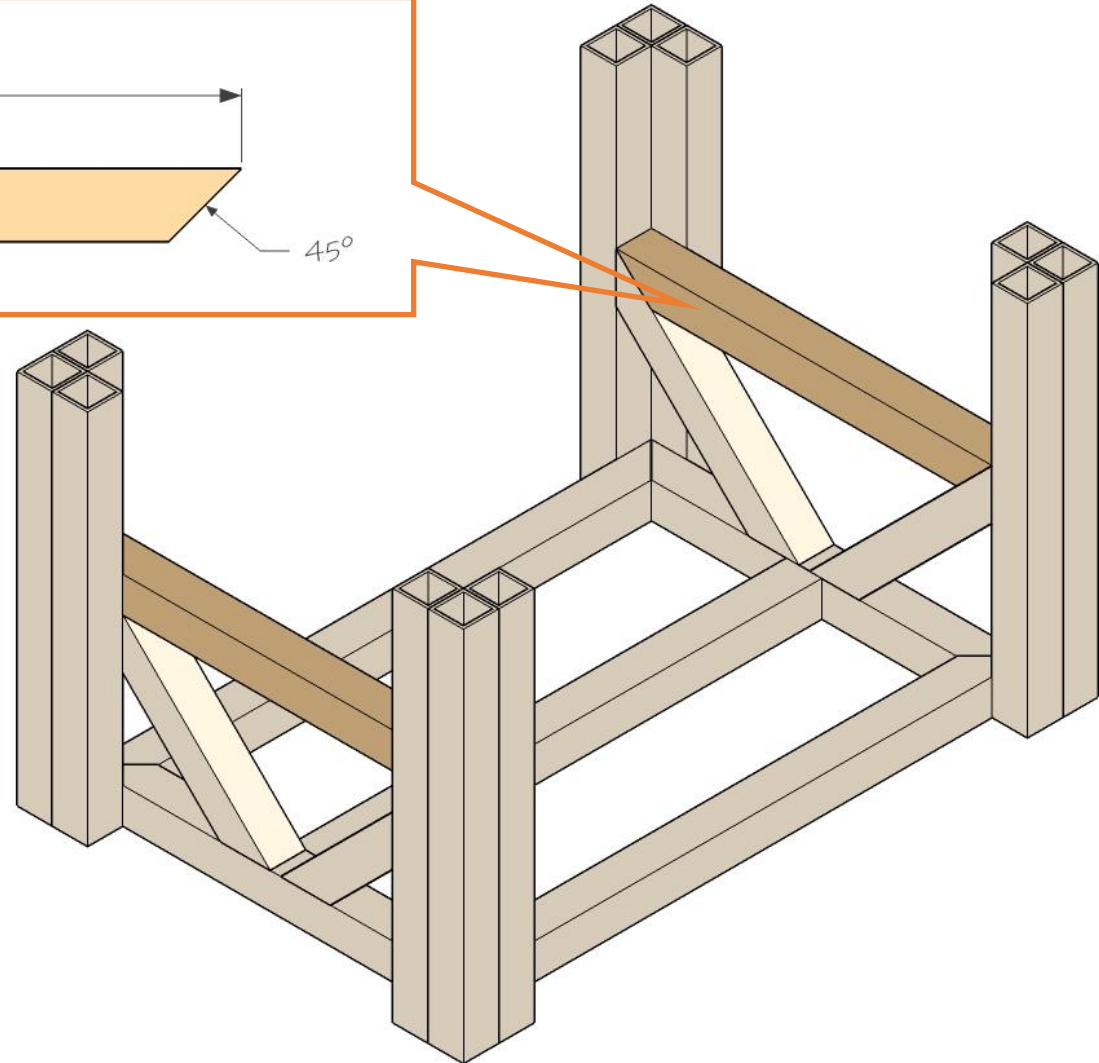
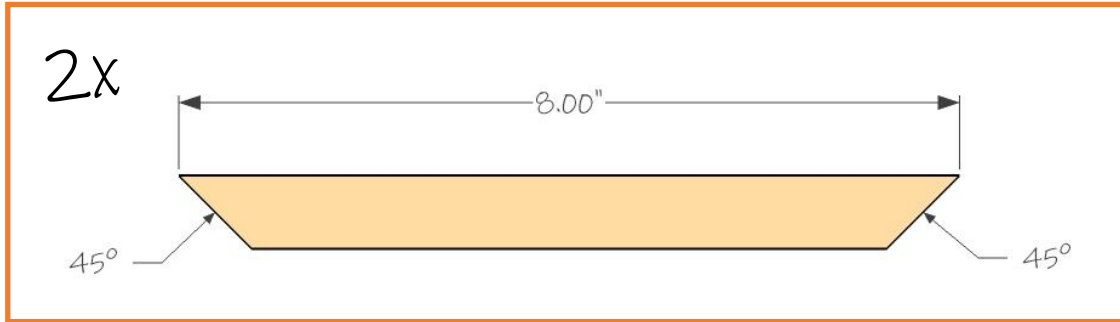

Step
5

Cut and glue diagonal support structures on the long end.

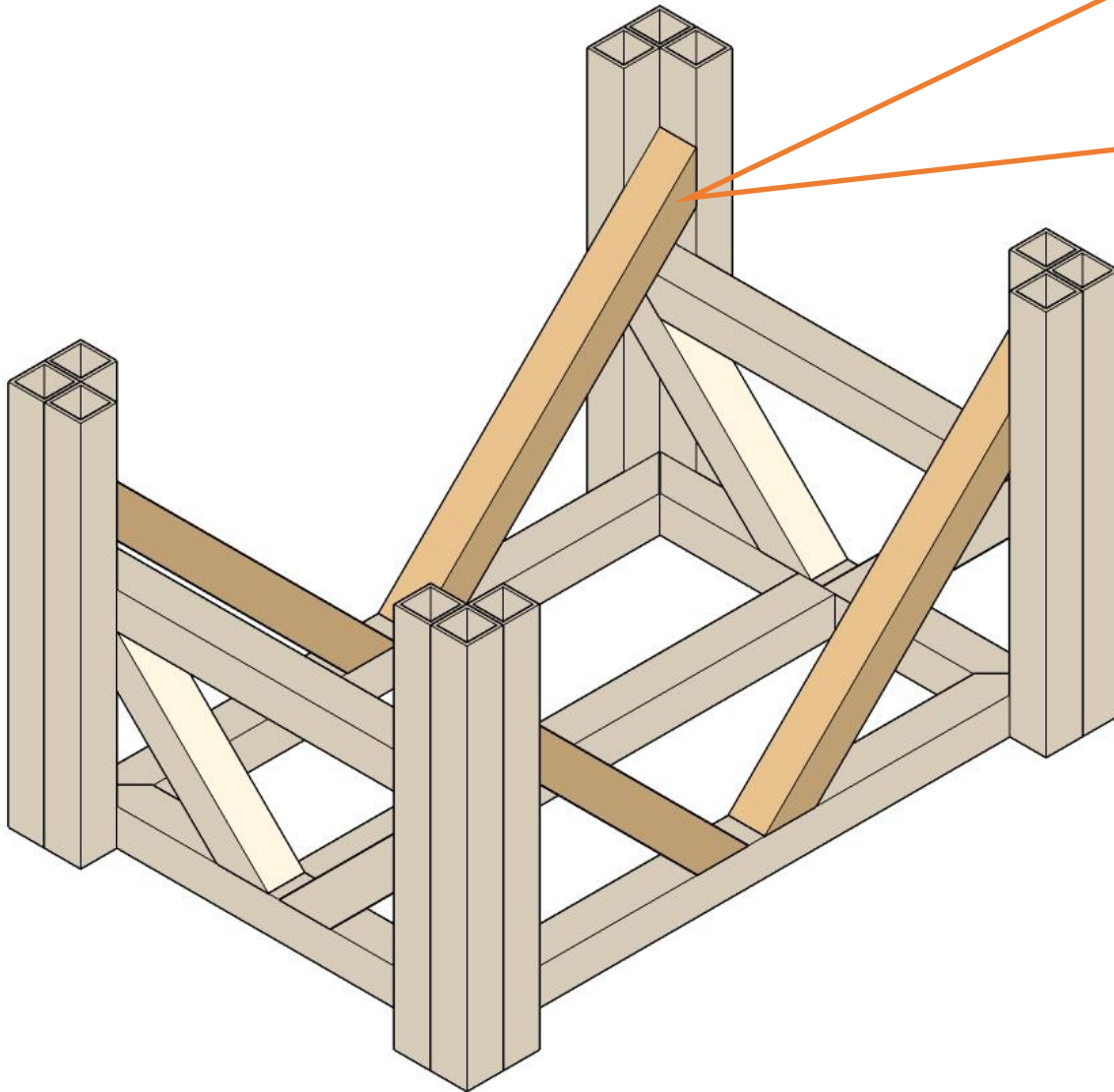

4x

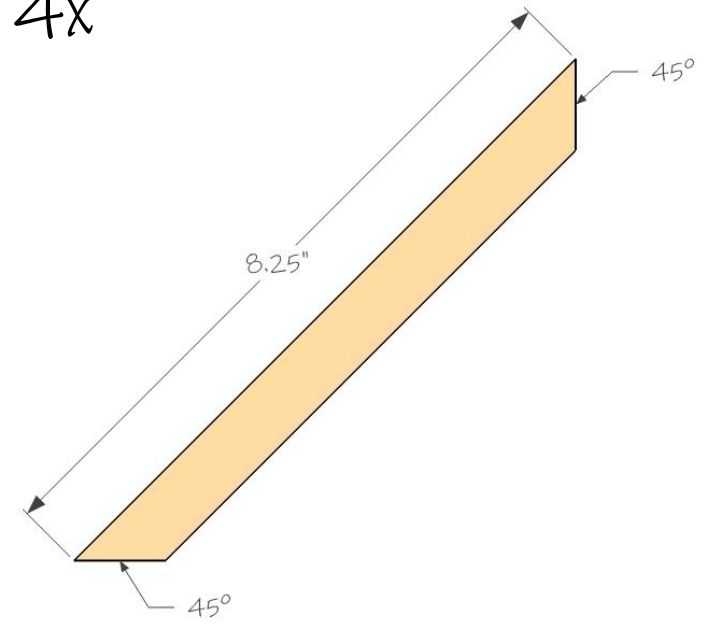

Step
6

Cut and glue cross bar members on the long end.

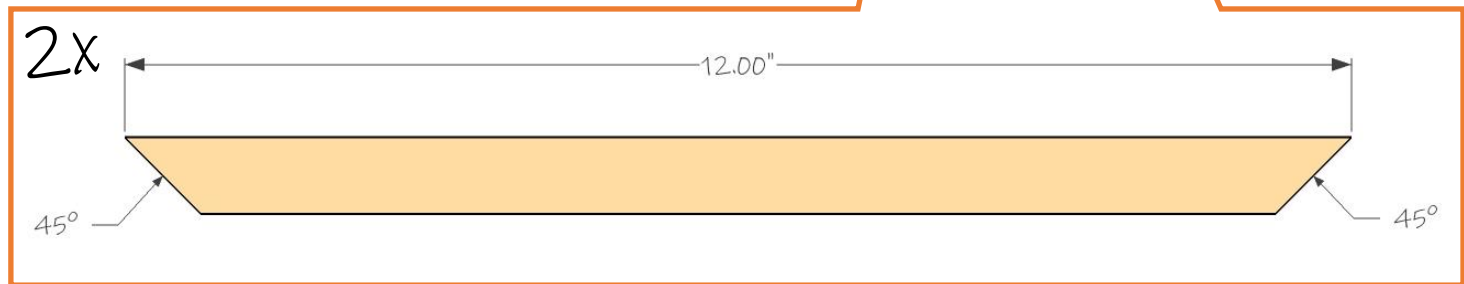
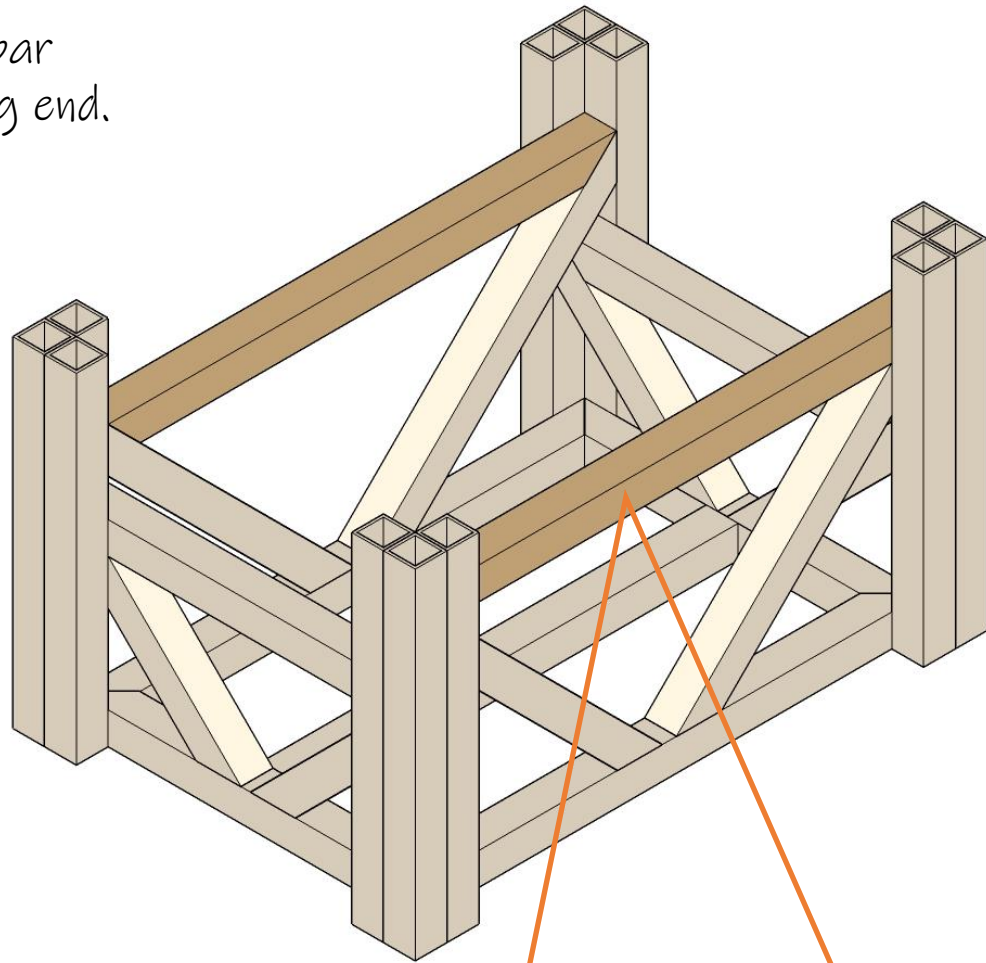

Step
7

Flip stool over and apply a few layers of cardboard to the top surface gluing each layer.

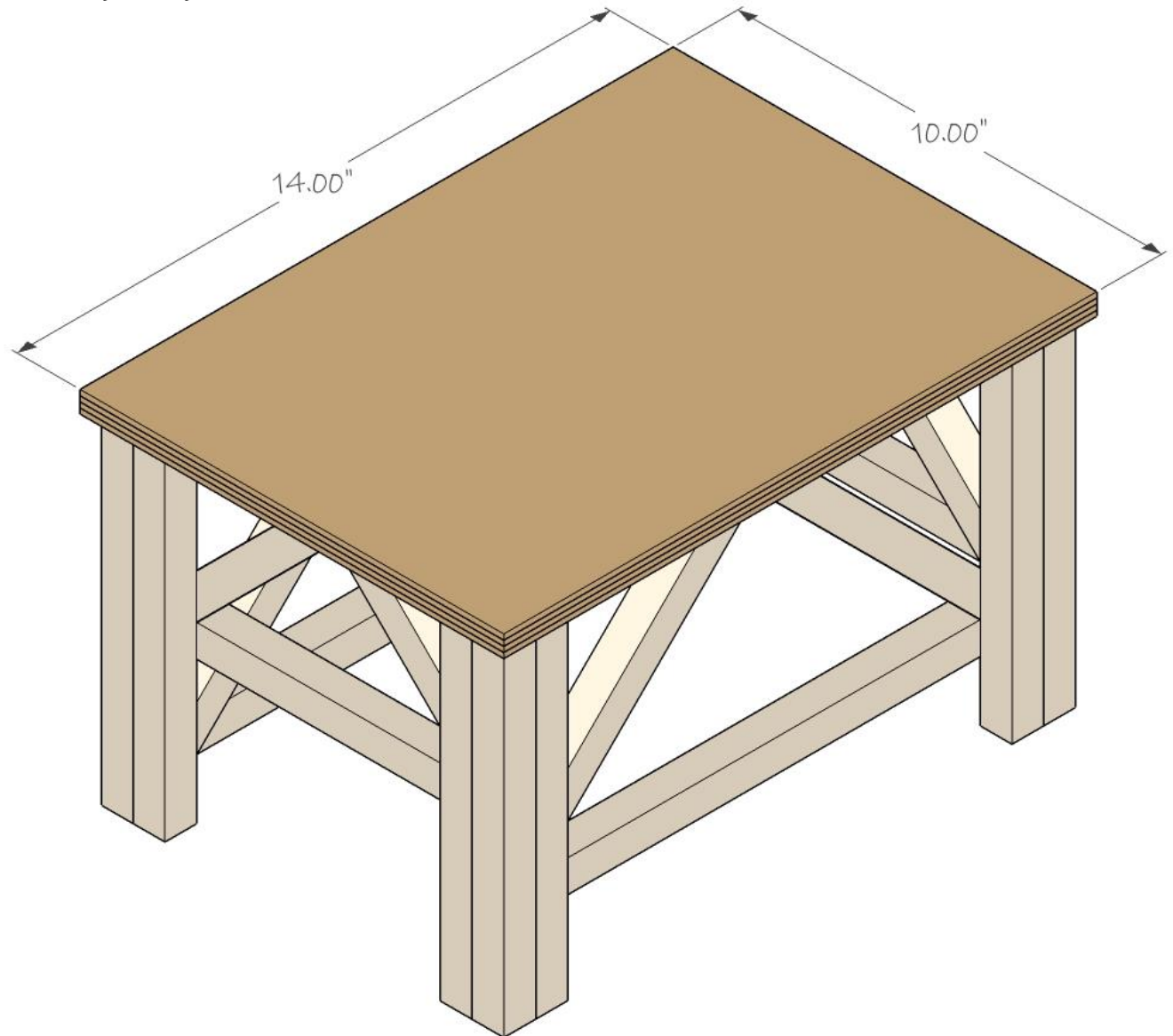

Step
8

Glue some strips of cardboard to the edge of the top surface for a more finished look. Paint and decorate your stool as you wish.

