

2016+ Nissan Titan Radio Removal Nissan Connect Factory Radio Upgrade

Dash Disassembly

1. Remove the (2) Phillips screws securing the knee bolster panel below the steering column, and then unclip the panel. It is not necessary to completely remove the panel. (Figure A)
2. Unclip and remove the passenger door sill and kick panel. (Figure B)
3. Remove the (5) T-20 Torx screws securing the glove box and then remove. There are (2) screws below the glove box, and (3) screws exposed when you open the glove box. (Figures C and D)

Continued on next page

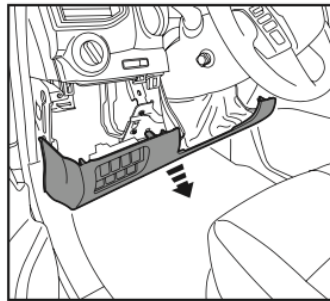

(Figure A)

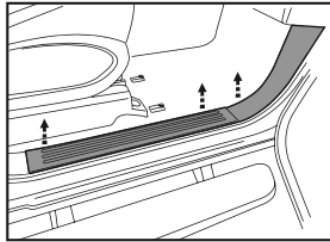

(Figure B)

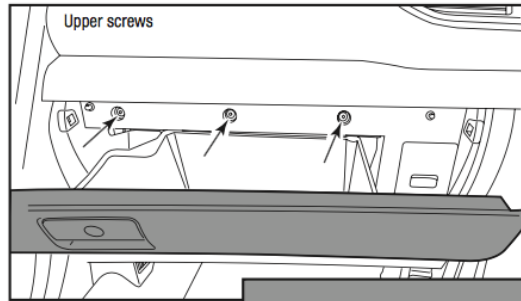

(Figure C)

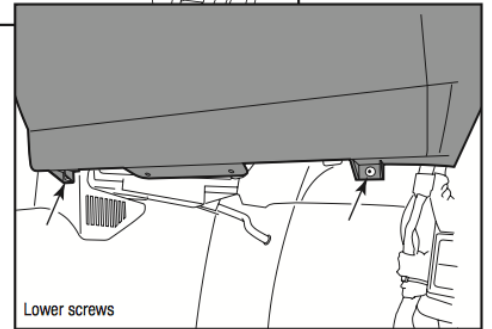

(Figure D)

Dash Disassembly

4. Unclip and remove the (2) side trim panels at the front of the center console, and then remove the (1) Phillips screw exposed behind each panel. *Tip: Pull out on the front sides of the console to release for later steps.* (Figure E)
5. Slide both of the front seats forward and then remove the (2) 12mm bolts from the rear sides of the center console. Slide the seat back once done. (Figure F)
6. Unclip and remove either the front console pocket or heated seat controls, depending on options available. (Figure G)

Continued on next page

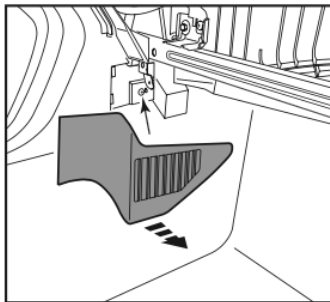

(Figure E)

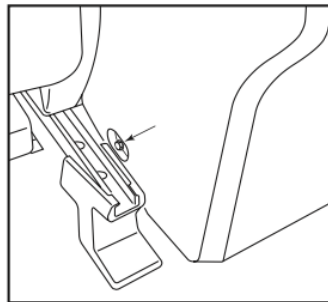

(Figure F)

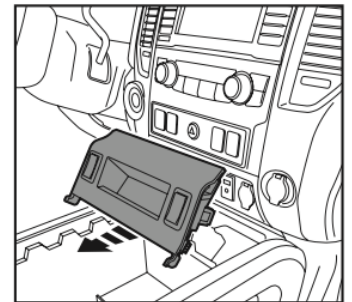

(Figure G)

Dash Disassembly

7. Unclip and remove the trim panel where the center console and the dashboard meet, and then remove the (2) Phillips screws exposed. (Figure H)
8. Slide the center console back, and then unclip and remove the vent panels from each side of the radio/ climate control panel. (Figure I)
9. Remove the (2) Phillips screws securing the accessory panel below the climate control panel, and then unclip and remove. (Figure J)

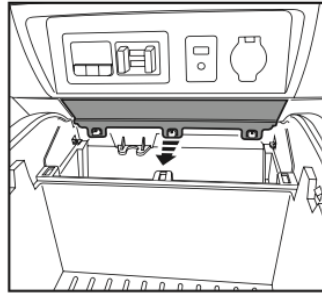

(Figure H)

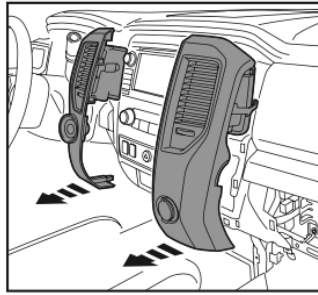

(Figure I)

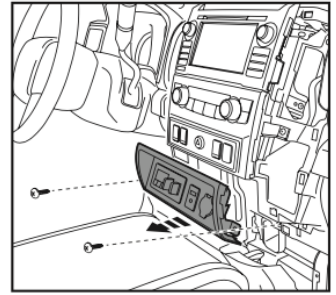

(Figure J)

Continued on next page

Dash Disassembly

10. Remove the (2) Phillips screws securing the climate control panel and then remove. (Figure K)
11. Remove the (4) Phillips screws securing the radio and then remove. (Figure L)
12. Slightly loosen the (8) T-20 Torx screws securing the radio brackets. Remove the (2) T-20 Torx screws securing the "white" climate control module below the radio and then remove. This module will be reused in kit assembly. (Figure M)

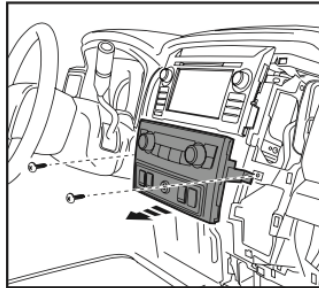

(Figure K)

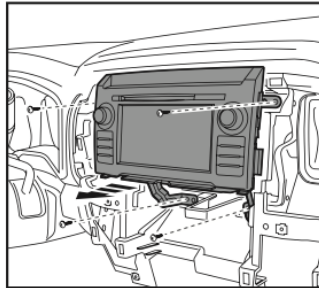

(Figure L)

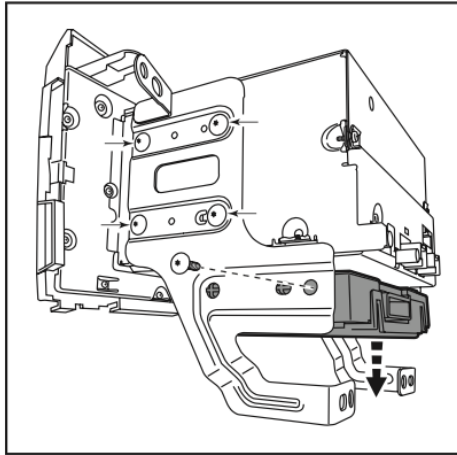

(Figure M)

Continue to kit assembly