



ROGGEERS
For the Perfection of Football Fundamentals™

PRODUCT INFORMATION PACKET

PRODUCT NAME: POP – UP TACKLE MAKER

PRODUCT PART NUMBER: 410454 – 410456

PATENT #D466963

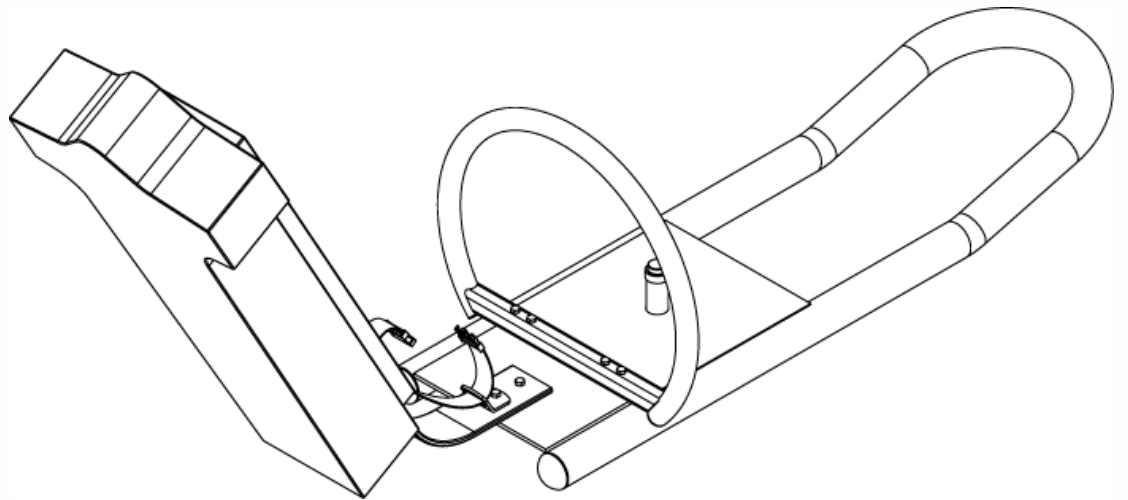

KEEP INFORMATION PACKET FOR FUTURE REFERENCE

TABLE OF CONTENTS

▪ Introduction.....	1
▪ General Safety Rules.....	2
▪ Symbols.....	3
▪ Technical Specifications.....	4
▪ Assembly Instructions.....	5
▪ Maintenance.....	6
▪ Customer Service Information.....	6

INTRODUCTION

The Rogers Athletic Pop-Up Tackle Maker has been designed and manufactured with safety, performance and dependability as top priorities, making it easy to operate and maintain.

The care you give your Pop-Up Tackle Maker will greatly determine your satisfaction with its performance and service life. Careful study of this manual is encouraged to obtain a thorough understanding of your new Pop-Up Tackle Maker and its functions.

If your manual is lost or destroyed, Rogers Athletic will gladly provide you with a new copy. Should you require additional information or assistance, please feel free to contact us at 800-457-5337.

BECAUSE ROGERS ATHLETICS MAINTAINS AN ONGOING PROGRAM OF PRODUCT DEVELOPMENT AND IMPROVEMENT, WE RESERVE THE RIGHT TO MAKE IMPROVEMENTS IN DESIGN OR CHANGES IN SPECIFICATIONS WITHOUT INCURRING ANY OBLIGATIONS TO INSTALL THEM ON UNITS PREVIOUSLY SOLD.

GENERAL SAFETY RULES



WARNING!





READ AND UNDERSTAND ALL INSTRUCTIONS.

Failure to follow all instructions listed below may result in serious personal injury.

SAVE THESE INSTRUCTIONS

- **Supervision of athletes while using the equipment is recommended.** Horse play such as climbing on the machine or using the machine for unintended purpose can result in injuries.
- **Athletes should be oriented in the proper use of the equipment.**
- **Athletes should be properly fit to engage in a workout regimen.** Obtaining a medical exam prior to beginning any training program is recommended. If an athlete feels faint, dizzy, or experiences pain at any time while exercising, they should stop exercising and consult a physician.
- **Inspect equipment prior to use.** DO NOT use if it appears damaged or inoperable.
- **This Product Information Packet is an integral part of this machine.** Save these instructions. If they are lost or damaged or if you would like another copy, a copy can be downloaded from www.RogersAthletic.com
- **Reading the Product Information Packet is recommended.** Failure to read this Packet is considered a misuse of this equipment.
- **Warning labels are an integral part of this equipment.** Become familiar with all caution/warning labels and never cover or deface caution/warning labels.
- **Deploy the equipment allowing sufficient room for safe access to the machine, adequate room for the coaches to stand and to ensure that the machine or players do not collide with a wall, another machine, or other players through the entire training exercise.**
- **Unit is designed for training defensive tackling drills with proper technique.** Do not use Pop-Up Tackle Maker for anything other than its approved purpose.
- **Equipment is designed for use by one person per pad at a time.** Keeping other athletes and spectators away from the machines during use is recommended.
- **Design and execute training drills to avoid players from attempting to run through the same gap between the sled units simultaneously.** Colliding players could come in contact with the sled unit and/or connecting link resulting in an injury.
- **When not in use, store this equipment in a secure controlled area.** Unsupervised and/or inappropriate use of this equipment could result in serious injury.
- **Always wear a helmet when training with the Pop-Up Tackle Maker**

SYMBOLS

	<p>Safety Alert: Precautions that involve your safety</p>
<div style="border: 1px solid black; padding: 5px;"> <div style="background-color: orange; color: white; padding: 2px; text-align: center;">⚠ WARNING</div> <div style="display: flex; align-items: center;">  <div> <p>Store in secure area. Inappropriate use of this equipment could result in serious injury.</p> </div> </div> </div>	<p>Store this equipment in a secure, controlled area: Unsupervised and/or inappropriate use of this equipment could result in serious injury.</p>
<div style="border: 1px solid black; padding: 5px;"> <div style="display: flex; align-items: center;">  <div style="border: 1px solid black; padding: 2px;"> <div style="background-color: yellow; color: black; padding: 2px;">⚠ CAUTION</div> <p>Avoid Injury. Do not climb.</p> </div> </div> </div>	<p>Do not stand, climb, or ride on the field equipment: Improper use of the field equipment may result in personal injury.</p>
<div style="border: 1px solid black; padding: 5px;"> <div style="display: flex; align-items: center;">  <div style="border: 1px solid black; padding: 2px;"> <div style="background-color: yellow; color: black; padding: 2px;">⚠ CAUTION</div> <p>Pinch Point. Keep Hands And Fingers Clear</p> </div> </div> </div>	<p>Pinch Point Warning Label: Failure to keep hands away from pinch points will result in personal injury</p>

ROGERS ATHLETIC POP-UP TACKLE MAKER SPECIFICATIONS

POP – UP TACKLE MAKER (PART # 410454-410456)

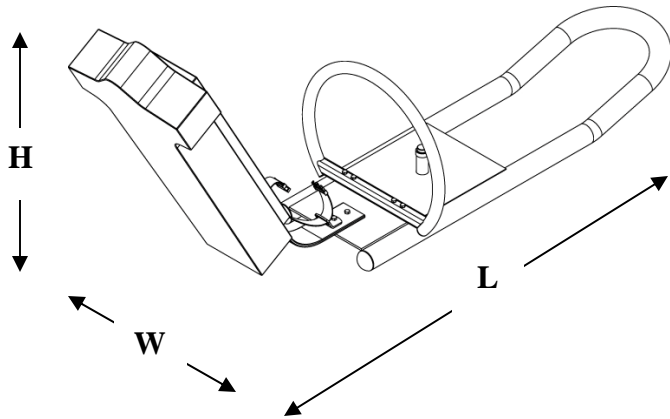

Weight:	Varsity = 190 lbs (86 kg) JV = 130 lbs (59 kg) Youth = 110 lbs (50 kg)
Height:	Varsity = 60" (152cm) JV = 47" (119cm) Youth = 47" (119cm)
Length:	Varsity = 122" (310cm) JV = 100" (254cm) Youth = 92" (234cm)
Width:	Varsity = 31.5" (80 cm) JV = 28" (71cm) Youth = 24.5" (62cm)

- Once tackled to the ground, sled returns to the upright position in seconds.
- Weight stack bar on Varsity and JV models accepts up to 100 pounds of weight plates for increased tackle resistance.
- Spring action of the pad adds realism.

Pop-Up Tackle Maker Construction, Finish, and Hardware

- Constructed of ASTM specified steel.
- Pads covered with durable weather-resistant vinyl.
- Hardware Zinc plated to resist corrosion
- Durable Powdercoat finish for years of performance

ASSEMBLY INSTRUCTIONS

1

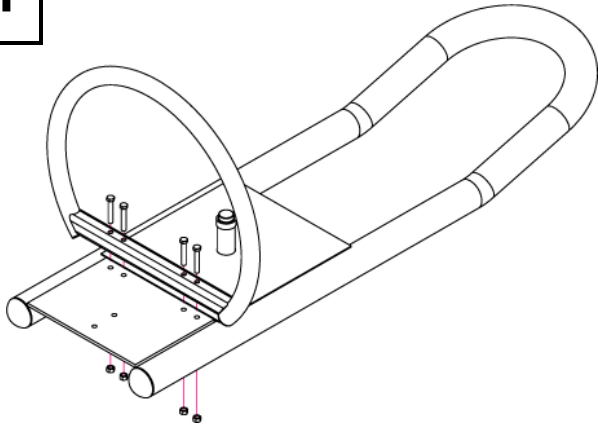

Note: 2 people required for assembly.

Affix the Tackle Sled Hoop to the Tackle Sled Runner using (4) $\frac{1}{2}$ " x 3" bolts and (4) $\frac{1}{2}$ " nuts. This step is easiest with another person to help lift the sled on its side as you place the bolts.

2

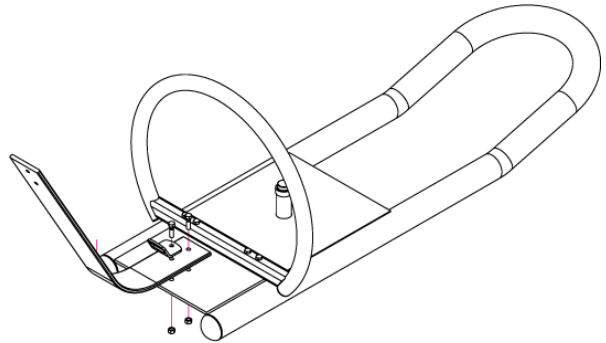

Use (2) $\frac{1}{2}$ " x $1\frac{3}{4}$ " bolts and (2) $\frac{1}{2}$ " nuts to connect the Tackle Sled Leaf Spring and the Tackle Sled Pad Strap Bracket to the front of the sled assembly.

3

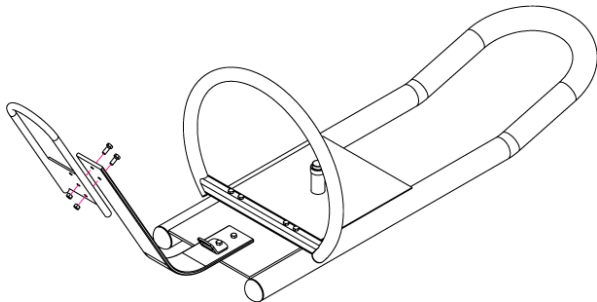

Attach the Tackle Sled Pad Frame to the leaf spring with (2) $\frac{1}{2}$ " x $1\frac{1}{2}$ " bolts and (2) $\frac{1}{2}$ " nuts.

4

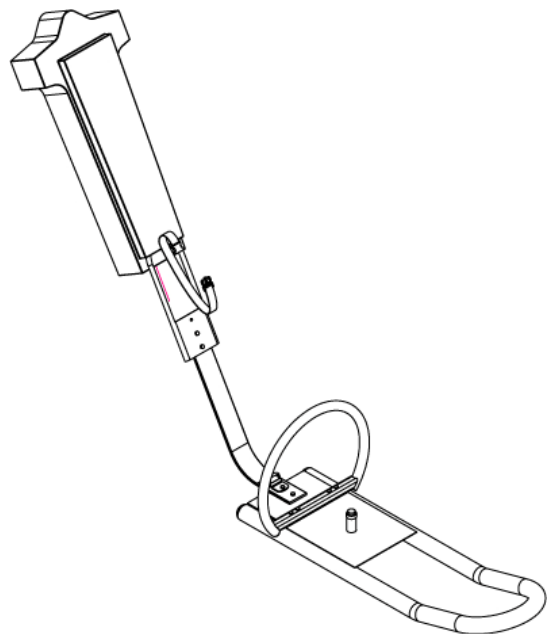

Slip Pad over Tackle Sled Pad Frame, thread pad strap through the Pad Strap Bracket, and connect the buckles. Pull strap tight.

MAINTENANCE



WARNING!

READ AND UNDERSTAND ALL MAINTENANCE PROCEDURES.

Failure to follow all procedures listed below may cause serious injury and a decrease in the equipments functional existence.

- **Frequently check to see that all bolts are securely fastened.**
- **Touch up paint may be used to cover scratches or blemishes sustained through use.**
- **Field equipment should be washed periodically with soapy water to maintain original surface finish.**
- **A silicone based lubricant may be used on moving parts to maintain proper function.**
- **Replace any damaged equipment with genuine Rogers Athletic parts.** Failure to do so may result in unsafe equipment and/or personal injury.

CUSTOMER SERVICE

For parts or service contact Rogers Athletic Company. When ordering parts be sure to provide all relevant information available including the name and part number of the equipment purchased. This information is located on the cover of this product information package. Customer service hours are Monday through Friday from 8:00 a.m. to 5:00 p.m. Eastern Standard Time. Customers can phone (989) 386-2950 or toll free at 1-800-457-5337. Fax toll free at (888) 549-9659 or mail:

Rogers Athletic Company
3760 W. Ludington Drive
Farwell, Michigan 48622

Rogers Athletic Company
3760 N. Ludington Drive
Farwell, MI 48622
www.rogersathletic.com
(989) 386-2950
(800) 457-5337
Fax toll free (888) 549-9659

PIP410289