

PART 1 ASSEMBLING FRONT PORTEUR RACK

Objects not drawn to scale

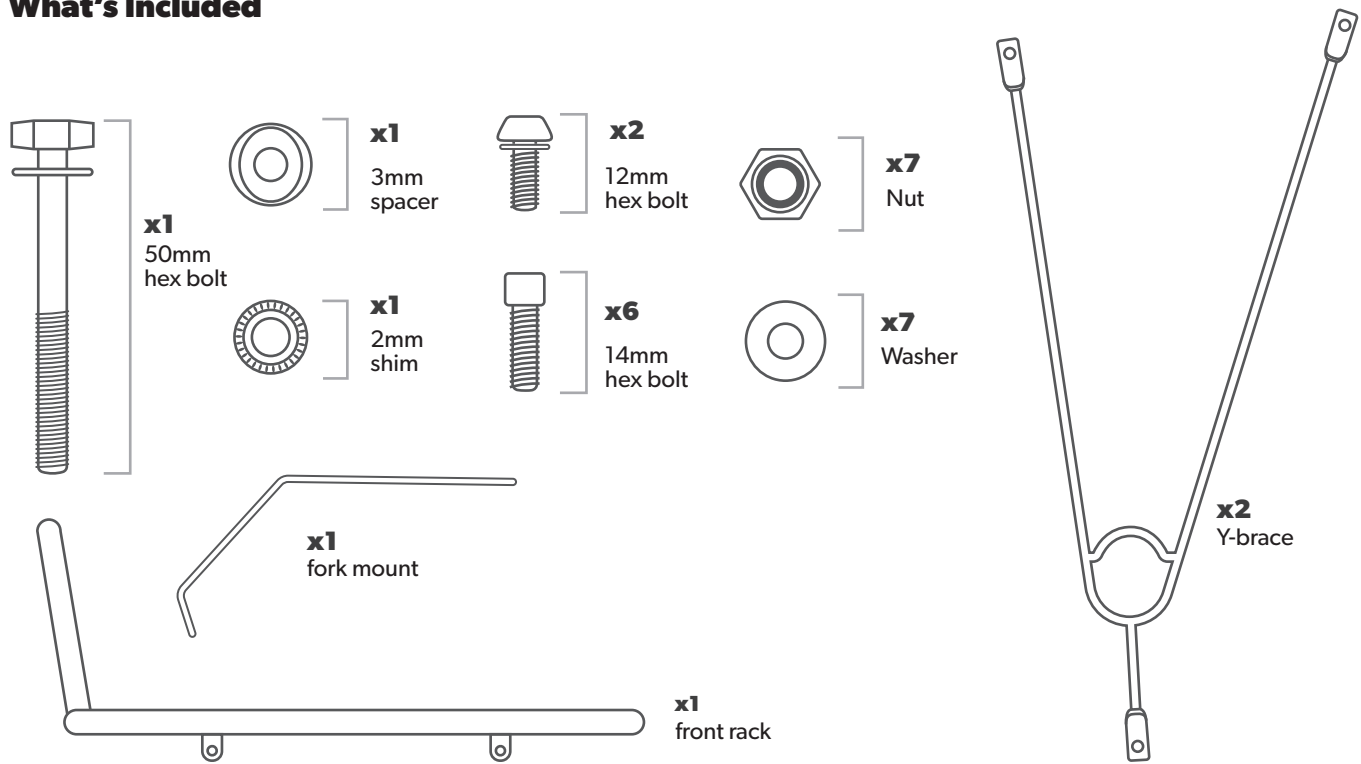

What's Included



Tooled Needed

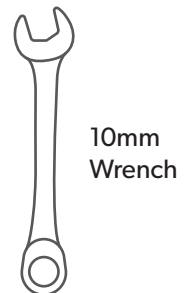
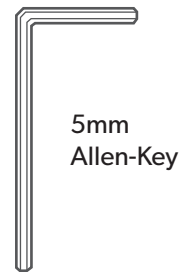
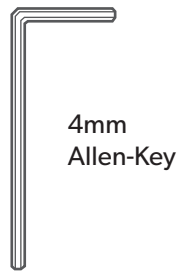

Assembly

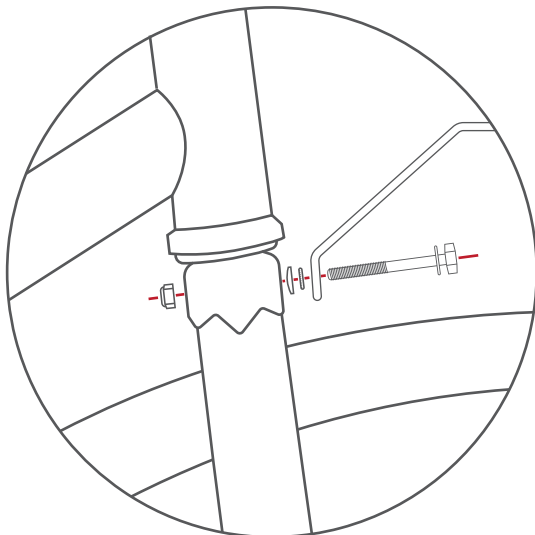

Instructions

Thread the 50mm bolt through the bracket, shim, spacer, fork mount, and fasten down nut.

Use the 5mm allen-key and 10mm wrench to tighten the fork mount to the bike.

PART 2 ASSEMBLING FRONT PORTEUR RACK

Objects not drawn to scale



Assembly

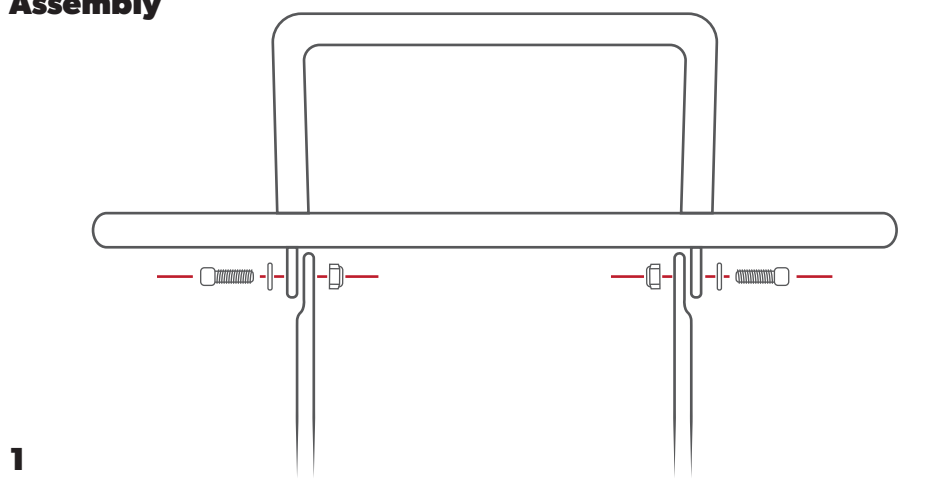

1

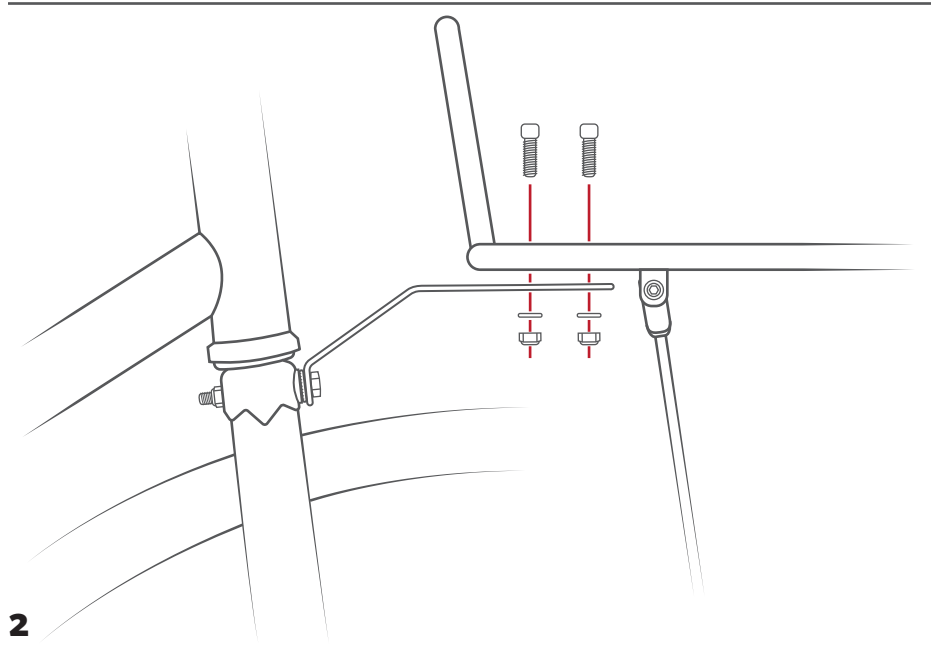

2

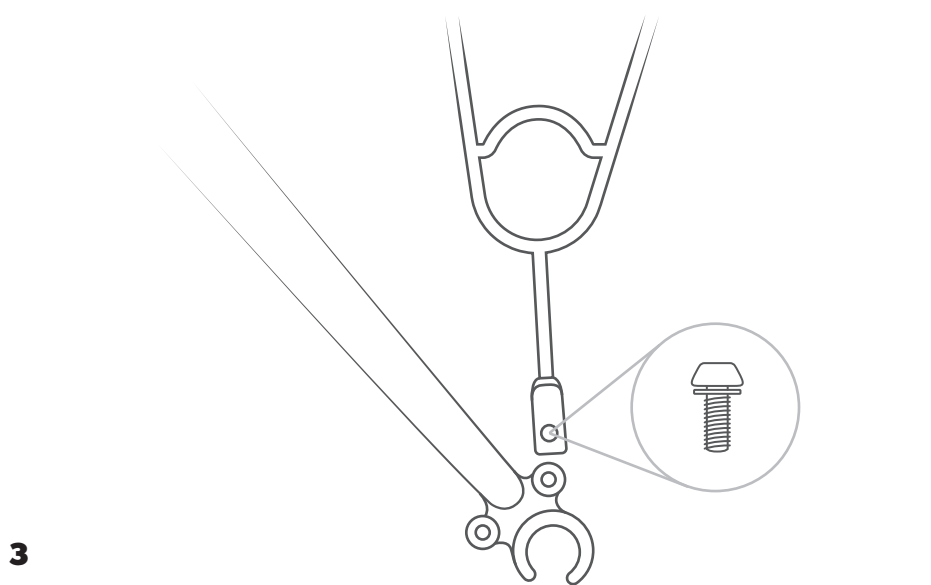

3

Instructions

Thread 2 sets of 14mm bolts through the washers and Y-braces, attaching them to the front rack.

Use the 5mm allen-key and 10mm wrench to tighten the bolts.

Once the Y-braces are firmly attached to the front rack - Thread two 14mm bolts through the holes in the middle bar of the front rack, fork mount, washer, and nut.

Use the 5mm allen-key and 10mm wrench to tighten the bolts.

Attach the bottom of the Y-brace to the front fork with a 12mm bolt.

Use the 4mm allen-key to tighten the bottom of the Y-brace to the front fork of your bike.

The front rack is now attached.

PART 3 ATTACHING FRONT CRATE TO PORTEUR RACK

Objects not drawn to scale



Assembly

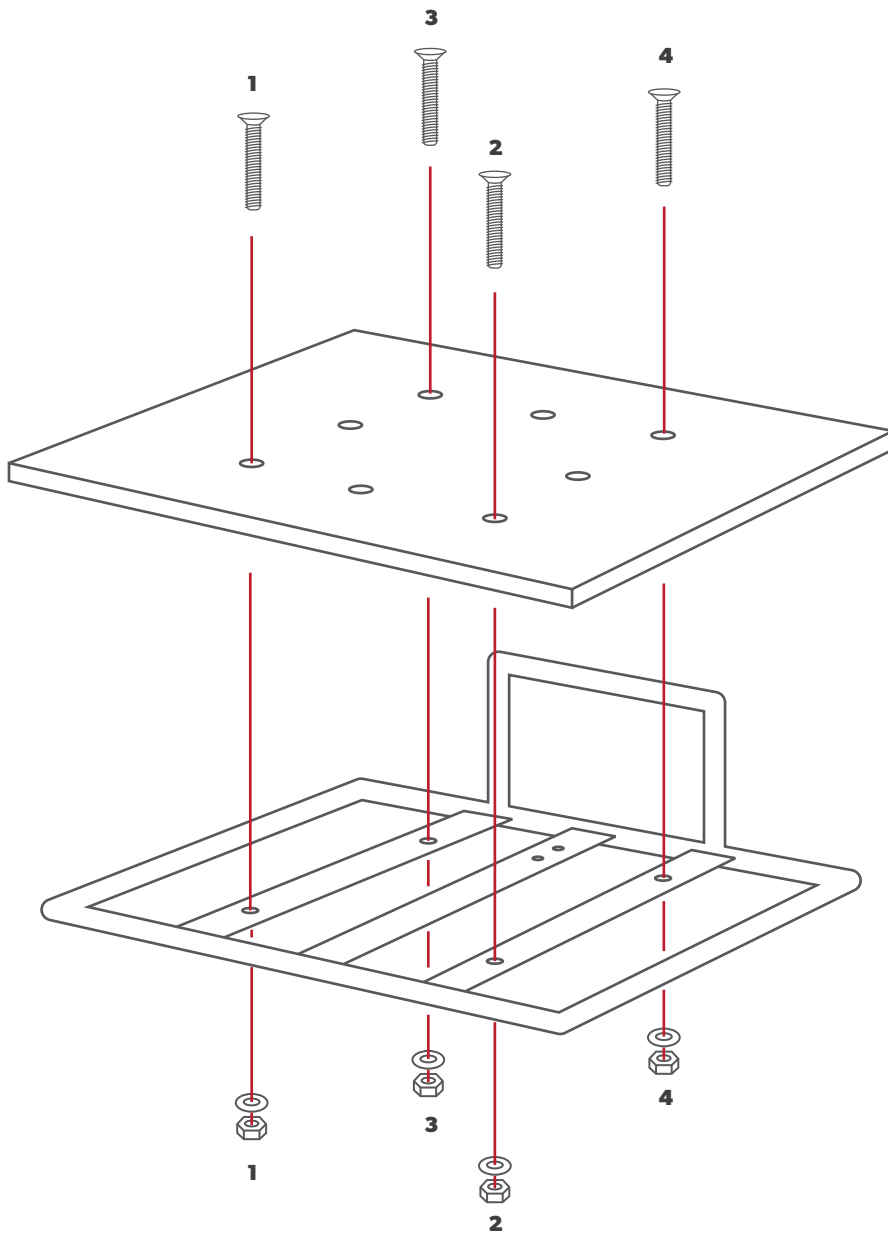

Instructions

Place the crate on the rack.

The side with the two holes for the bottle opener should be facing forward.

Thread the 35mm bolts 1 and 2 through the pre-drilled holes in the crate. Repeat this step with bolts 3 and 4.

Thread the bolts through the holes in the front rack.

Once all of the bolts are through the front rack, slide on the washer followed by the nut and tighten by hand.

Tighten with the 5mm allen-key and the 10mm wrench to hold the nut in place.

Tighten all four bolts in an alternating fashion until the crate is well secured.

The crate is now installed.