

MITSUBISHI TRITON INSTALLATION MANUAL

Installation time

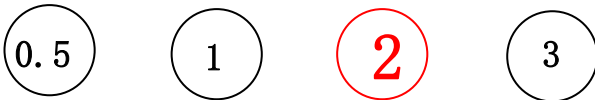

Professional installation recommends



Tools



12mm 13mm



Attention:

We highly recommend you to find professional store to install the product.

Attention:

not follow the instruction may damage the ECU, motor or the car.

MITSUBISHI TRITON INSTALLATION MANUAL

COMPONENTS LIST



Running board,
2 PCS



ECU

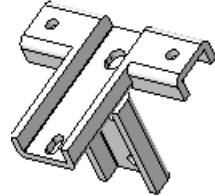

Bracket connection, rear 2

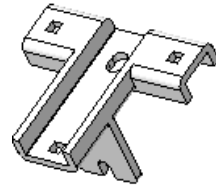

Bracket connection, middle 2

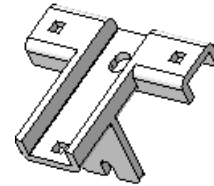

Bracket connection, front 2



Idler bracket 4



Motor bracket 2



OBD KIT 1 SET

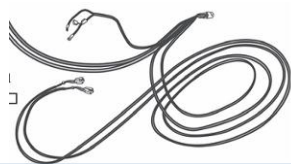

Wire harness: one set for
motor power and signal



M8*30 socket cap
screw 6PCS



N6*25 socket cap
screw 12 PCS



M8 nut w conical
Washer 6 PCS



Plastic line 1



U shape washer
10pcs



M8 washer
6 PCS



M6 spring
washer 12PCS



M6 washer 12
PCS



Tie wire
20 PCS

Screw package

MITSUBISHI TRITON INSTALLATION MANUAL

1. 1. Install ECU, OBD and wiring



1) 1) take out fuse



2) connect power wire to battery: red one with fuse is positive.



3) Caution: **Tighten battery screw very tight! If loose, may get damage to the car**



4) the positive line from here to cabin



5) the positive line from here to cabin

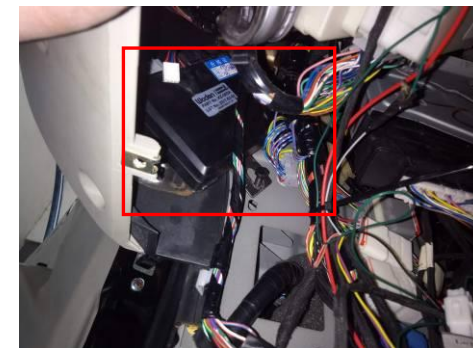

6) put ECU here and fix it

MITSUBISHI TRITON INSTALLATION MANUAL



7) fixing ECU as above picture



8) negative position



9) motor line from chassis to cabin



10) motor line from chassis to cabin



11) another motor line to co-drive side



12) get information from door swithes

mitsubishi triton installation manual



13) switch is on each door, use the connector inside

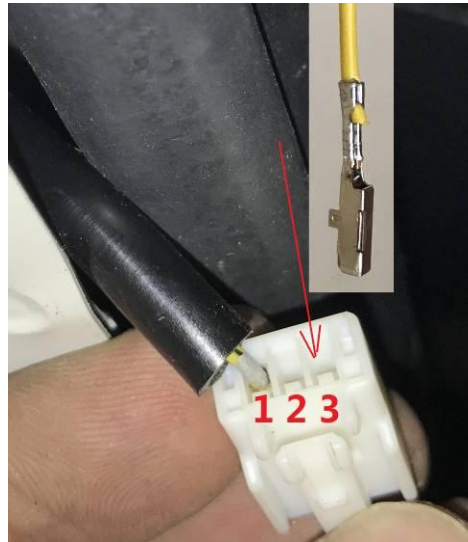

14) insert the signal line into Pin no. 3 and protect it with tape. Four doors are the same way to install.

15) connect the motor connectors and use tape to protect. Connect line with ECU connector. Insert fuse to test if motor works well.

mitsubishi Triton Installation Manual

2. install connection (right side, 2 sides in same way to install)

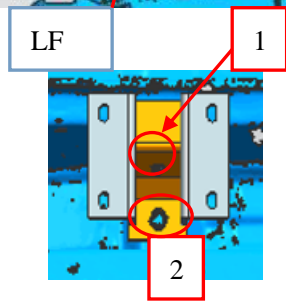
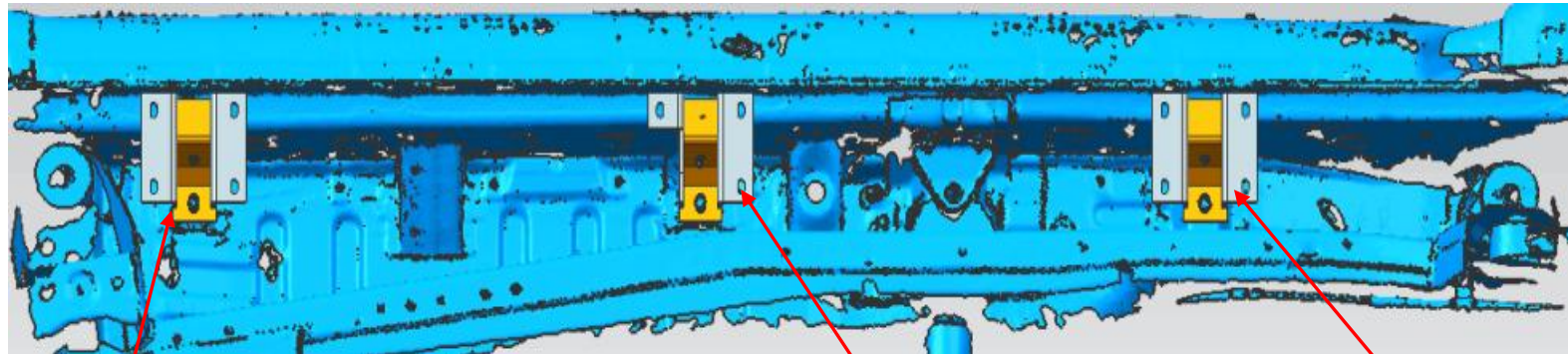
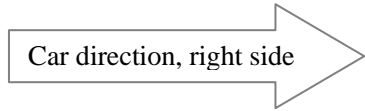

M8 nut

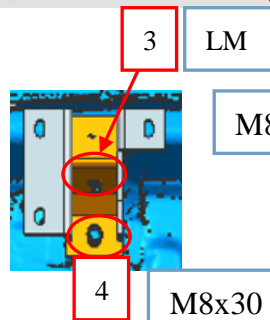

M8 nut

M8x30 socket cap screw

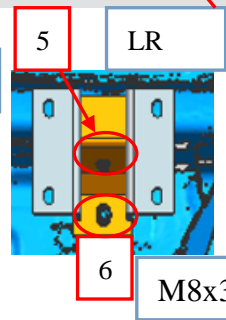

M8x30 socket cap screw

Tighten all screws !

mitsubishi Triton Installation Manual

3. install right brackets (right side, 2 sides in same way to install)

Car direction, right side

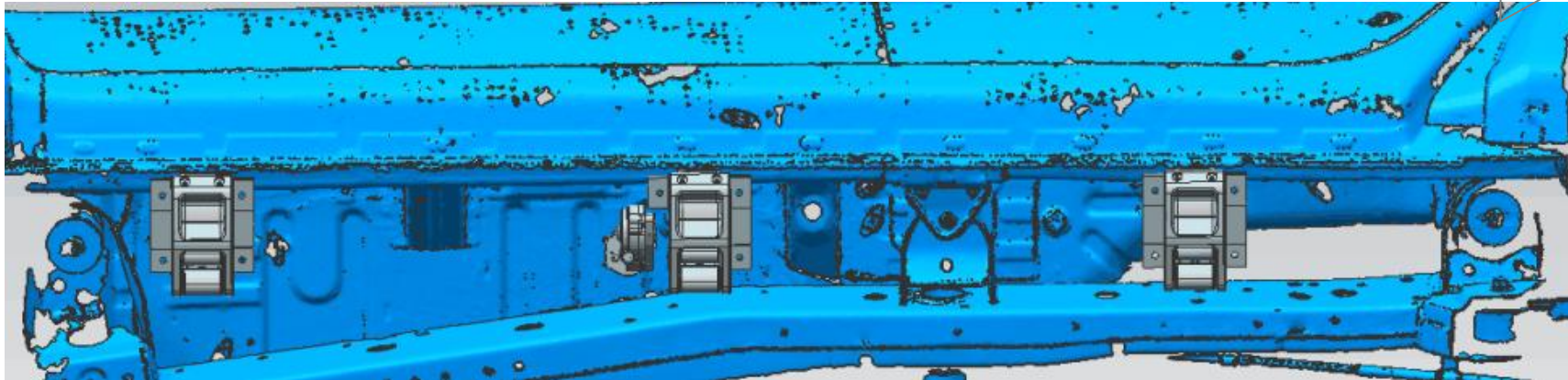

1.2.3,4 use M8x30 screws and nuts to fix.

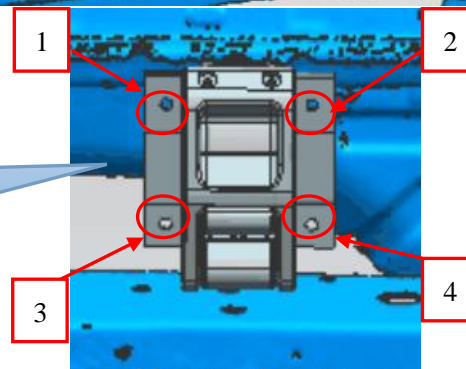

3 brackets are in same way to fix

KEEP ALL BRACKETS SCREW A LITTLE LOOSE, SO THAT BRACKET CAN MOVE WITH RUNNING BOARD!!!

MITSUBISHI TRITON INSTALLATION MANUAL

4. install running board (left and right side are in same way)

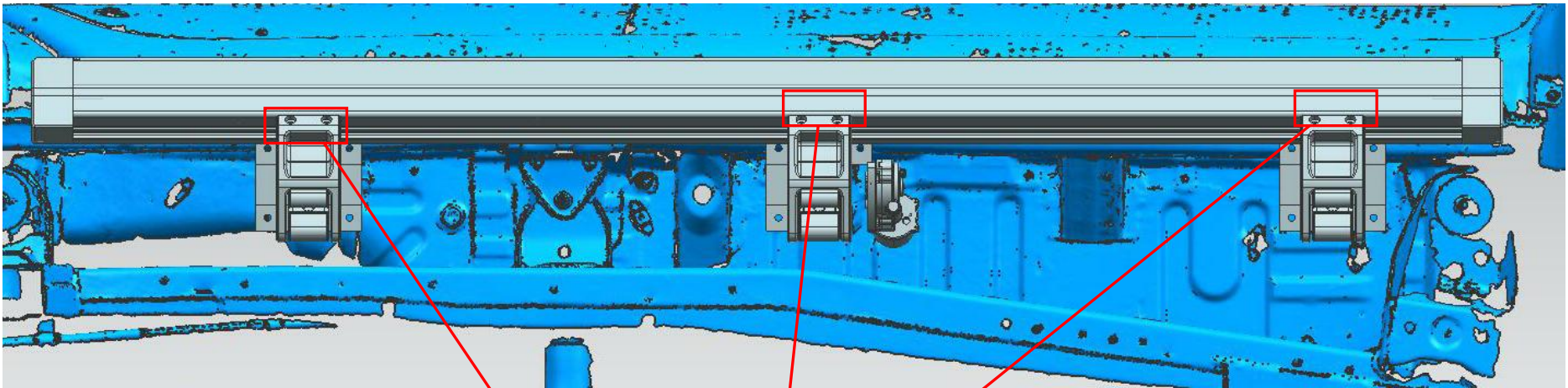

Use M6x25 screw and spring washers to fix running board with brackets.

TIGHTEN SCREWS !

MITSUBISHI TRITON INSTALLATION MANUAL

5. Testing and adjust the balance

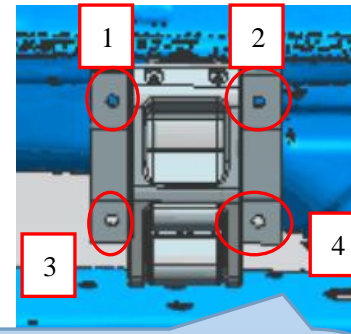

Insert fuse again. Then open and close doors to let step work. To assure them up and down freely to adjust position by itself.

**FASTEN ALL THE SCRWS
(4x6=24) ON THE 6 BRACKETS**

If still not balance, use U shape washer to adjust it.

MITSUBISHI PAJERO SPORTS INSTALLATION MANUAL

Checking all doors activate, the side step work when doors open and close.
Now the installation is finished. Protect all connectors with tap to avoid loose



To lift the car as showed



To lift the car

MITSUBISHI PAJERO SPORTS INSTALLATION MANUAL



To changing tire

Automatic power deploy:

The running boards will extend down and out when the door is opened.

Automatic stop:

If an object is in the way of the moving running board, the running board will automatically stop. To reset, clear any obstruction, then simply open and close the door to resume normal operation.

Manually set in the deployed (OUT) position for access to the roof:

Step your foot while at the same time closing the door. To resume normal operation, open and close the door.

Maintenance: In adverse conditions, debris such as mud, dirt, and salt may become trapped in the running board mechanism, possibly leading to unwanted noise. If this occurs, manually set the running boards to avoid spraying the motors directly. After washing, apply silicone spray lubricant to the hinge pivot pins.

Caution! Keep hands and feet away when the running board is in motion.