

1 2 3 4 5 6 7 8 9 10 11 12 13 14 15 16 17 18 19 20 21

1
2
3
4
5
6
7
8
9
10
11
12

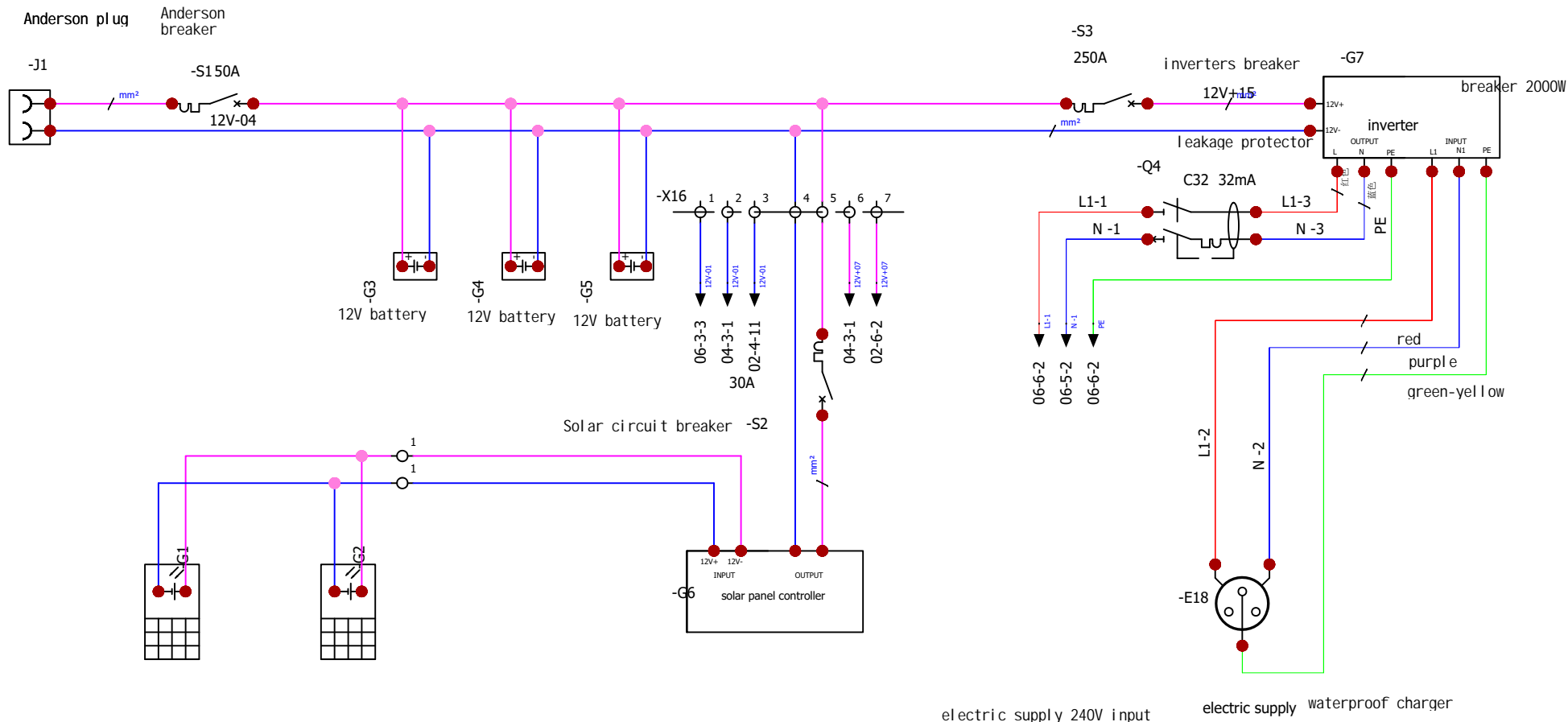

CONTRACT:		LOCATION: +L1		REVISION
				0
REV.	DATE	NAME	CHANGES	SCHEME
0	2022/5/18	Administrator		03

Entry position - Upper switch panel

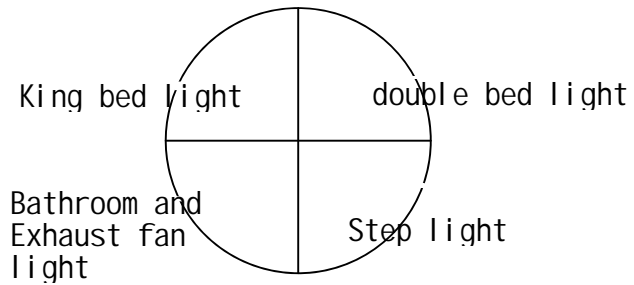

Double bed

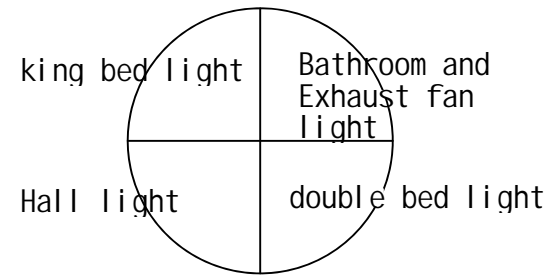

Entry Position - Lower switch panel

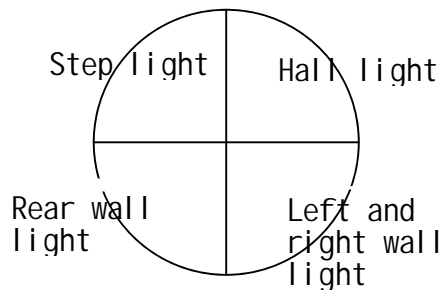

Eight position panel with light switch

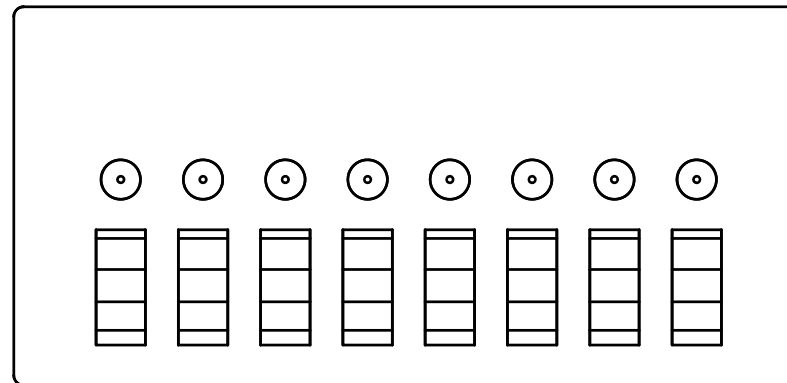

light switch refri gerator 20A waterh eater USB charge Water bump Range hood Water meter backlit Electric toilet Player switch

SOLIDWORKS Electrical

CONTRACT:	LOCATION: +L1	Functional diagram			REVISION
					0
		0	2022/5/18	Administrator	CHANGES
					08

1 2 3 4 5 6 7 8 9 10 11 12 13 14 15 16 17 18 19 20 21

1
2
3
4
5
6
7
8
9
10
11
12

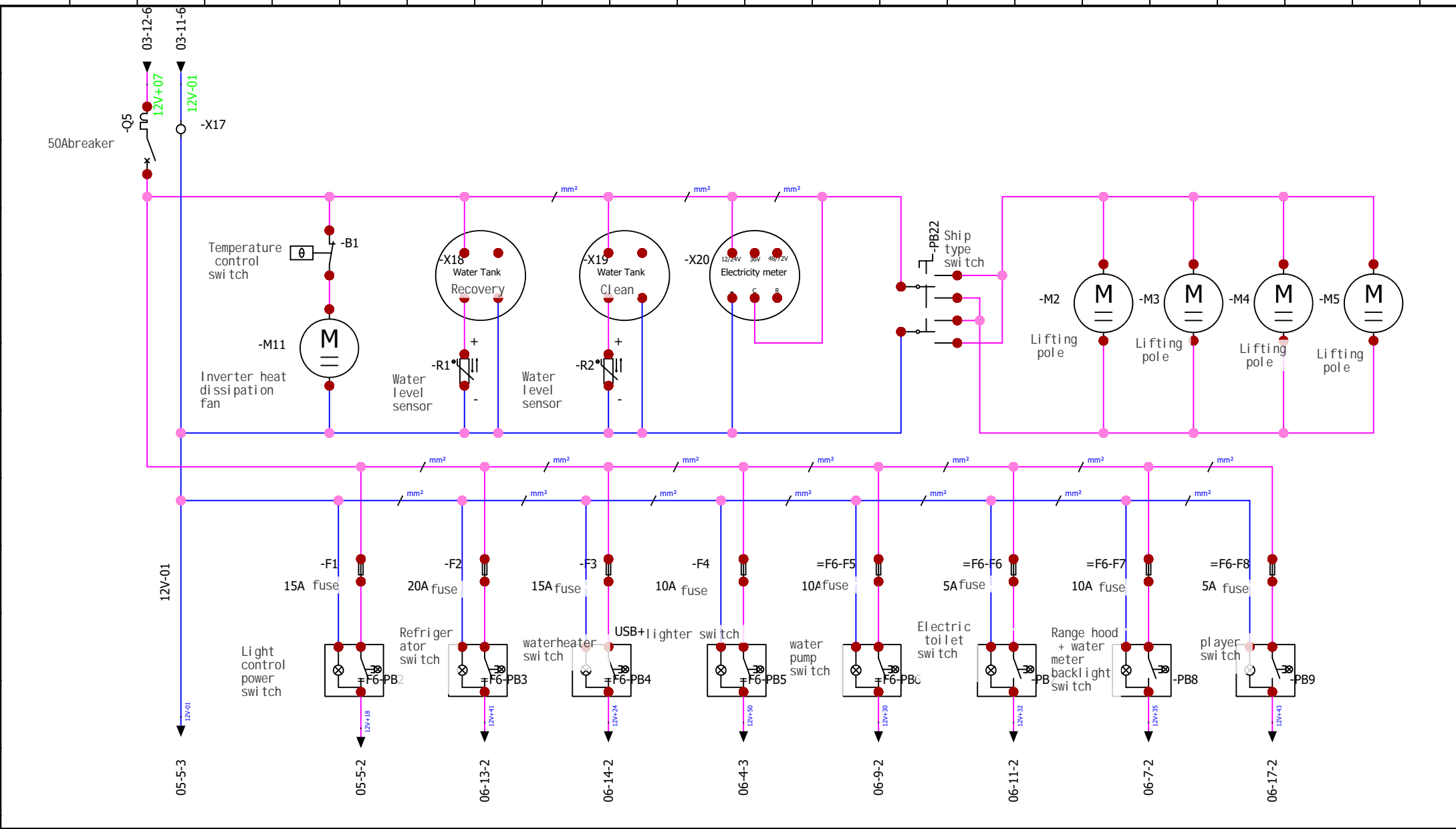

CONTRACT:		LOCATION: +L1		Control panel diagram		REVISION
						0
0	2022/5/18	Administrator				SCHEME
REV.	DATE	NAME	CHANGES			04

1 2 3 4 5 6 7 8 9 10 11 12 13 14 15 16 17 18 19 20 21

1
2
3
4
5
6
7
8
9
10
11
12

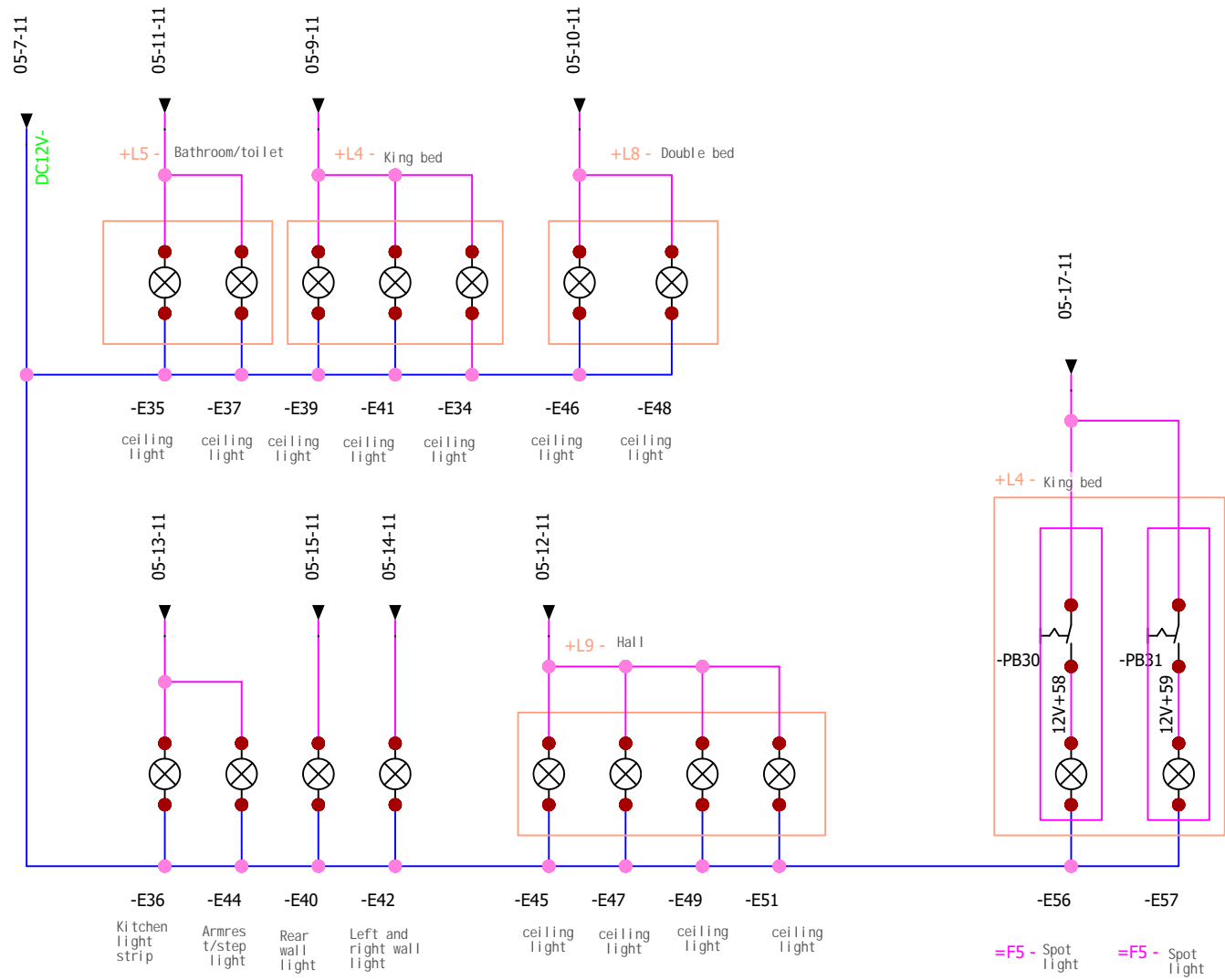

CONTRACT:	LOCATION: +L1	Lighting diagram				REVISION
						0
		0	2022/5/18	Administrator		SCHEME
		REV.	DATE	NAME	CHANGES	07

1 2 3 4 5 6 7 8 9 10 11 12 13 14 15 16 17 18 19 20 21

1
2
3
4
5
6
7
8
9
10
11
12

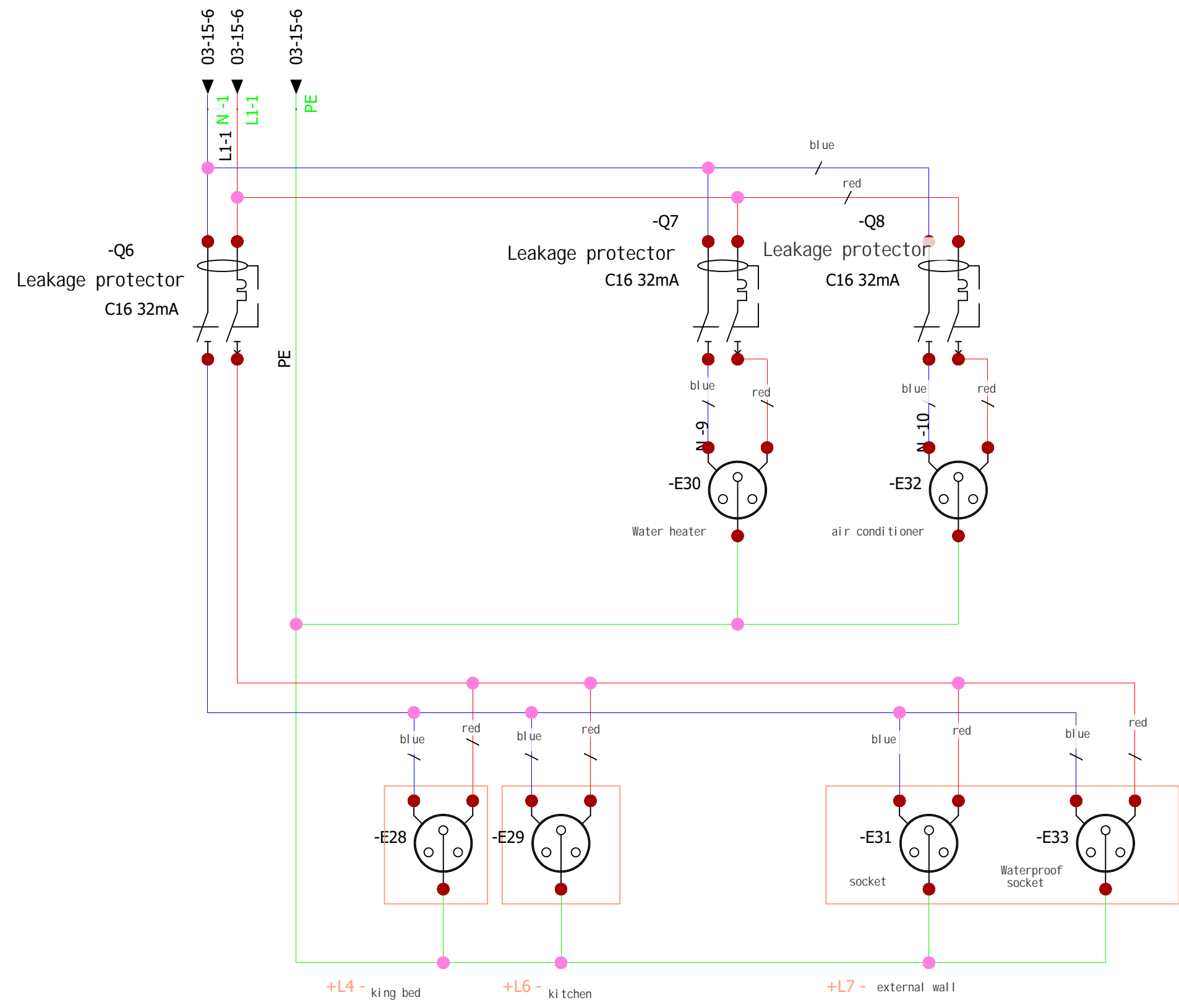

AC220V

CONTRACT:		LOCATION: +L1		REVISION	
				0	
0	2022/5/18	Administrator		SCHEME	
REV.	DATE	NAME	CHANGES		
				06	

1 2 3 4 5 6 7 8 9 10 11 12 13 14 15 16 17 18 19 20 21

1
2
3
4
5
6
7
8
9
10
11
12

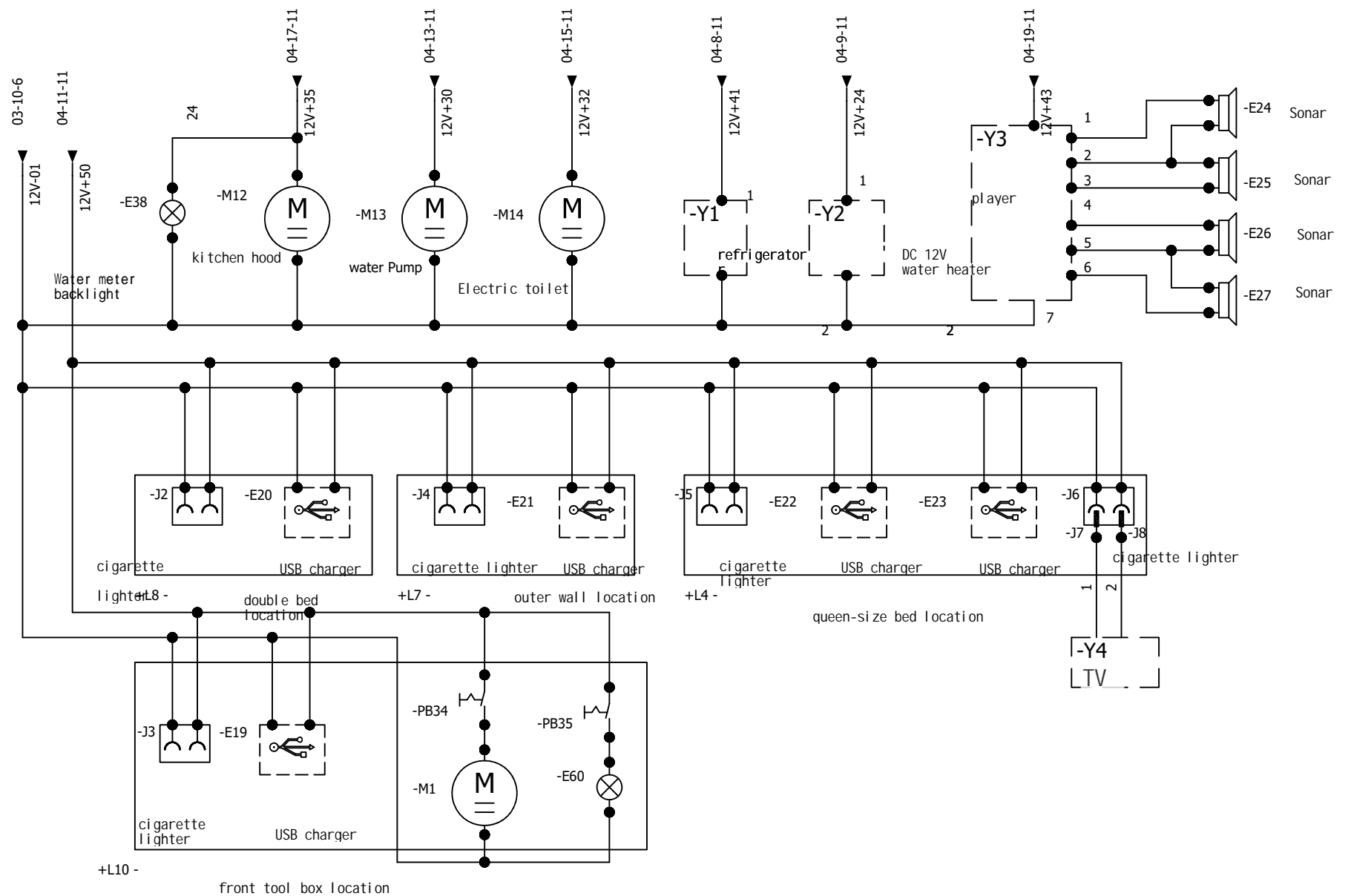

DC12V

CONTRACT:

LOCATION: +L1

				REVISION
0	2022/5/18	Administrator		0
REV.	DATE	NAME	CHANGES	SCHEME
				06

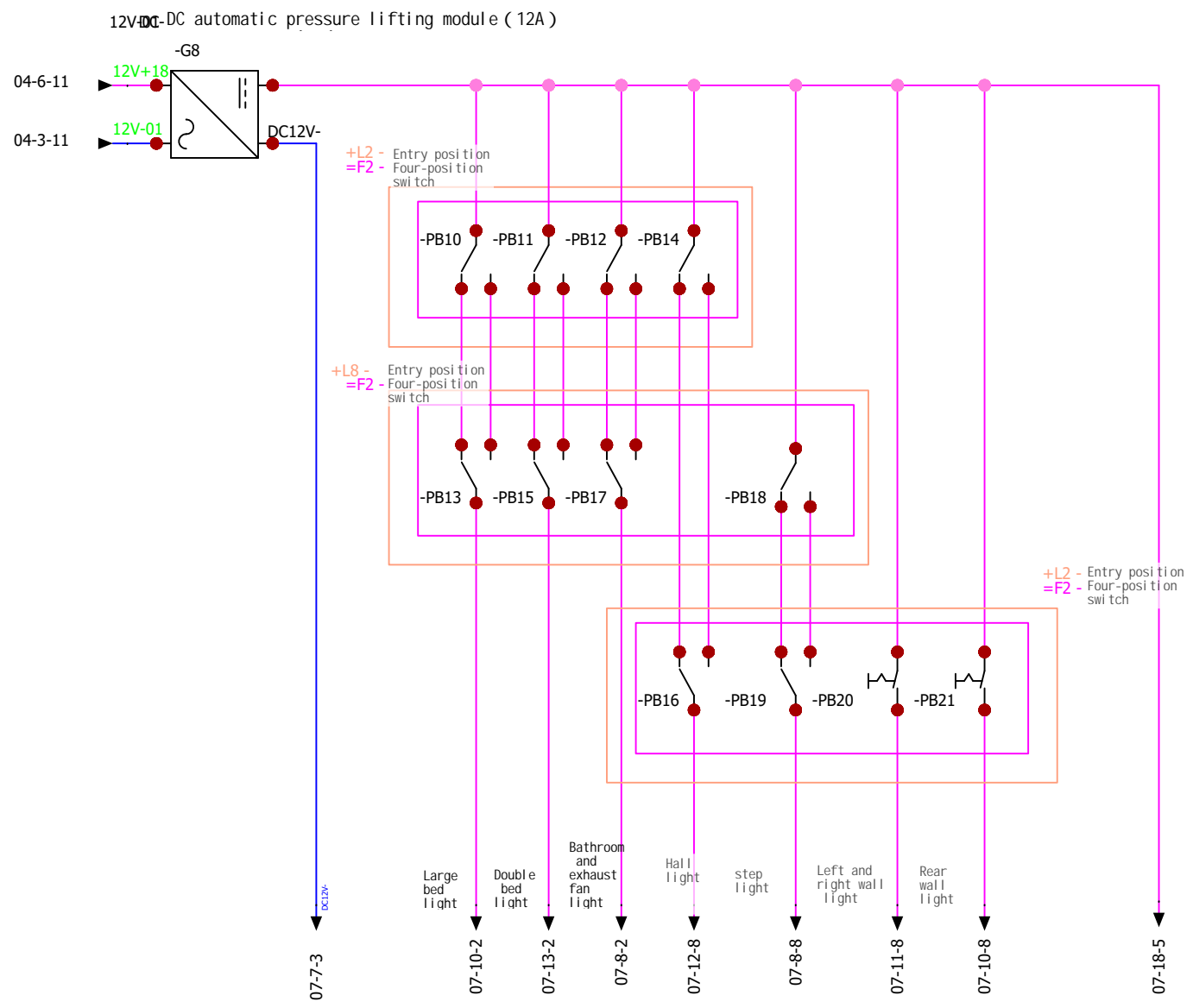

CONTRACT:		LOCATION: +L1		Light control switch diagram			REVISION
							0
0		2022/5/18		Administrator		CHANGES	SCHEME
							05

1 2 3 4 5 6 7 8 9 10 11 12 13 14 15 16 17 18 19 20 21

1
2
3
4
5
6
7
8
9
10
11
12

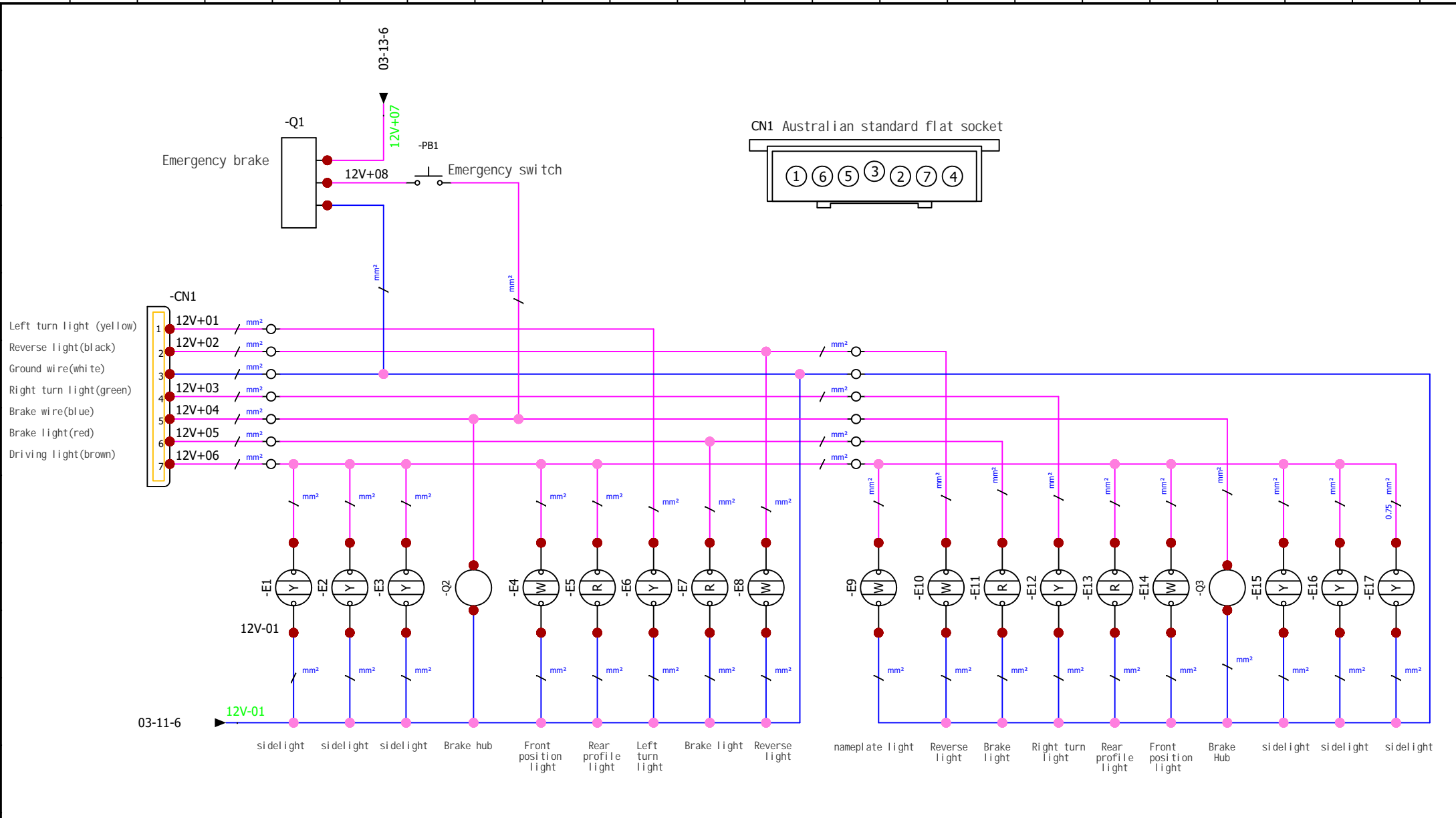

CONTRACT:		Chassis wire				REVISION				
						0				
LOCATION: +L1		0	2022/5/18	Administrator		SCHEME				
		REV.	DATE	NAME	CHANGES		02			