



# Welcoming

*a sustainable approach to merchandising*

Introducing the next generation of full-sized grocery merchandiser, True's retail Merchandiser (TRM) is an advanced self-contained cabinet built for large storage capacity and exceptional product display.



The TRM refrigeration system is charged and sealed at the factory using refrigeration R290, a natural, environmentally friendly future proof refrigerant.

## FEATURES

### Design

- True's commitment to using the highest quality materials and energy efficient refrigeration systems provides the user with colder product temperatures and lower utility costs.
- Take advantage of the install flexibility, convenience, and efficiency of this self-contained case. Fit TRM's through doorways, move the case into location, install the compact sealed condensing systems and plug it in. No refrigeration connections or technicians needed for install.
- Available in 2, 3, and 4 door models, the TRM's are ideal for multi-door case lineups, end cap placements, and general refrigeration storage applications.
- The entire cabinet structure is built using high-density, polyurethane insulation that has zero ozone depletion potential.
- Refrigeration redundancy architecture helps prevent product loss.

### Refrigeration System

- With the R290 Natural Refrigeration system, TRM is exempt from changing state and federal regulations.
- Environmentally friendly R290 Natural Refrigerant system.
- Self-contained factory-charged and sealed refrigeration system.
- The True Dynamic Refrigeration Response System allows for quick product pull down where and when cooling demand is needed.
- DOE and Energy Star approved.
- This unit listed under NSF/ANSI standard 7 for the storage and/or display of packaged products only.

### Accessories

- Peg-bar shelf for organized display of hanging products

### Electrical

- Unit completely pre-wired at factory and ready for final connection to a 208-240V-1PH-60Hz, cord and plug set included.



### Innovation

- Reverse condensing fan motor (RCU) technology helps prevent condenser blockage.
- Patented True Level leveling systems for a quick install.
- Plug-and-play electrical system for seamless installation (No refrigeration tech or electrician needed).
- High Efficiency Variable Speed Compressor Technology.

### Doors

- Self closing doors with stay open feature.
- "Low-E" double pane thermal insulated glass door.
- Viewable glass height of 70" for maximum product display.
- Magnetic door gasket of one piece construction, removable without tools for ease of cleaning.

### LED Lighting

- 4000k color temperature LED interior lighting, provides brilliant lighting throughout the cabinet.

### Shelving

- Total of 20 (5 per door) adjustable, solid white powder coated cantilever shelves 30W" x 25D".



## PLAN VIEWS

Cabinet illustrated includes the (NN) end panel.

PHYSICAL DATA	
LED Color Temperature	4000k
# Of Refrigeration Decks	2
Usable Capacity Cubic Ft	154.4
Internal Dimensions	123 1/4" x 31" x 68 1/8"
Cabinet Dimensions	128 3/8" x 39 7/8" x 102"
Door Type	Glass
Crated Weight (lbs)	1760
Interior Finish	White Aluminum
External Finish	Black Aluminum
Shelf Type Design	Cantilever
# Of Full Shelves	20
Full Shelf Dimensions	30 3/16" W x 25" D
Castors Legs/ Levelers	Leg Levelers
Stay Open Door Feature	Yes
ELECTRICAL & ENERGY DATA	
Daily Energy Use (Kwh/Day)	8.4
Energy Star Certified	Yes
Condenser Type	Air Cooled
Rejected Heat (Btu/h)	2614
Horse Power (Per Deck)	1 1/2 (2 x 3/4)
Total Amps	10.6
Cord Length	10'
Electrical Plug	NEMA-L6-30P
REFRIGERATION DATA	
Refrigerant Charge (per deck)	9oz (4.5 x 2)
Refrigerant	R290
Min. Temperature	32°
Max. Temperature	41°
END PANEL CONFIGURATION	OVERALL COMBINED LENGTH (IN)
TRM4-NN	128 3/8"
TRM4-YN	127 1/4"
TRM4-NY	128 3/8"
TRM4-YY	127 1/4"
<b>PANELS:</b>	
N = 2 1/2" (End panel)	
Y = 1 1/2" (In-line panel)	

### FRONT VIEW

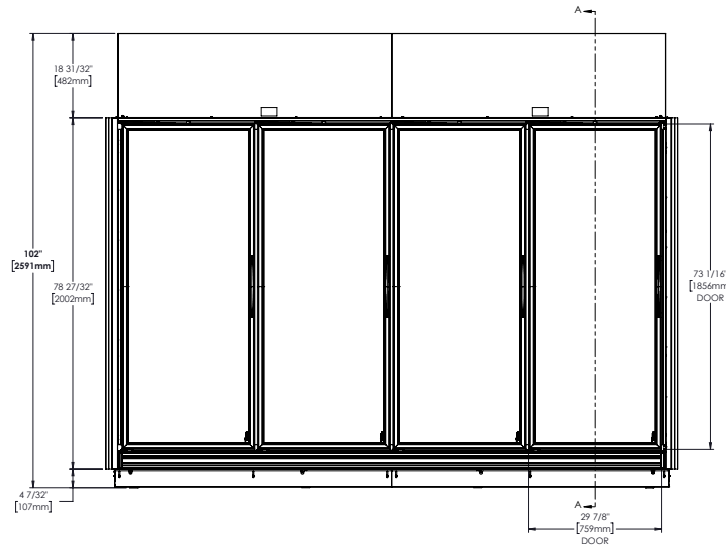

### SIDE VIEW

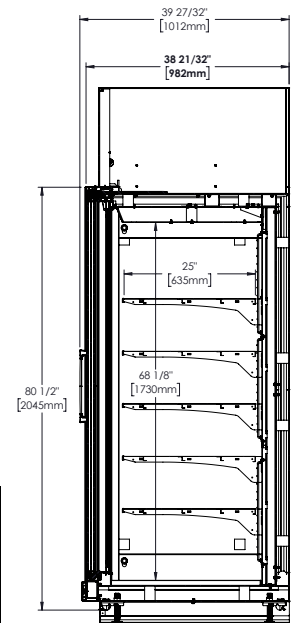

### TOP VIEW

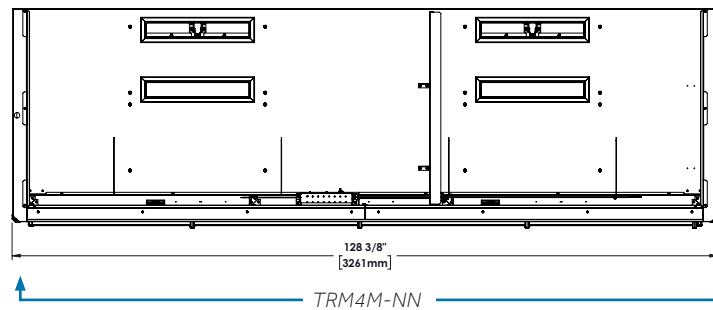

## TRM NOMENCLATURE

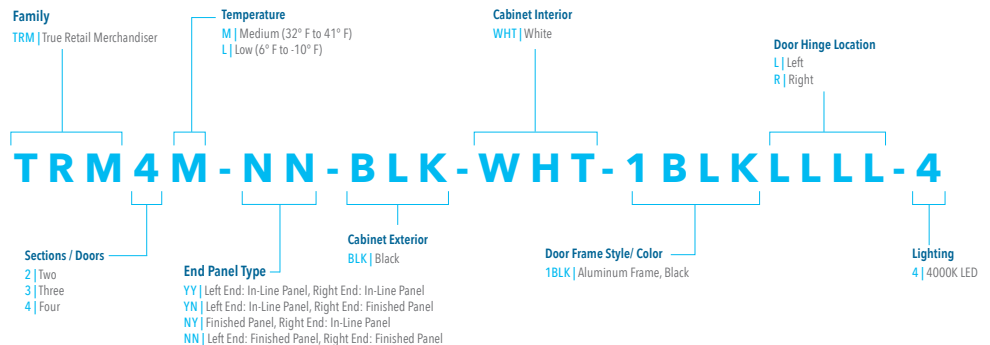

### END PANEL CONFIGURATION EXAMPLE

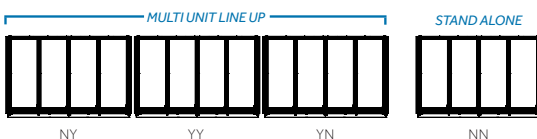

BC\_221670\_11.23

METRIC DIMENSIONS ROUNDED TO THE CLOSEST 1/8" OF AN INCH

SPECIFICATIONS SUBJECT TO CHANGE WITHOUT NOTICE



truemfg.com

