

Hypertherm®

DiaLine™

Dependable cutting head solutions



The most advanced cutting head technology in the industry

Precise power for every purpose

- Improved cutting speeds
- Reduced edge taper
- Increased production
- Reduced hourly cost of operation

The next level of worry-free cutting

Hypertherm has spent countless hours developing the industry's most comprehensive, smartly designed, and completely customizable cutting head available today. The DiaLine™ cutting head takes stream alignment to the next level and backs it up with an industry-best 600-hour warranty. DiaLine provides not only the most advanced cutting head technology on the market, but also the ability to customize the cutting head to meet the needs of your operation. If you want 1,000 hours of worry-free cutting, you need the DiaLine cutting head in your arsenal.

What sets DiaLine apart

Diamond orifice

- Best warranty in the industry (600 hours)
- Secure, precision diamond engagement produces concentric stream alignment to the nozzle
- Removable diamond mount provides maximum flexibility

Mixing chamber

- Produced from the most wear-resistant material for abrasive waterjet
- Anti-turbulent design reduces wear, protects diamond, and optimizes abrasive usage
- Easy access allows for periodic inspection and service (if required)

Nozzle nut

- Dual-piloting diameters precisely center the cutting stream to the carbide nozzle
- Precise nozzle alignment increases nozzle longevity by as much as 15%

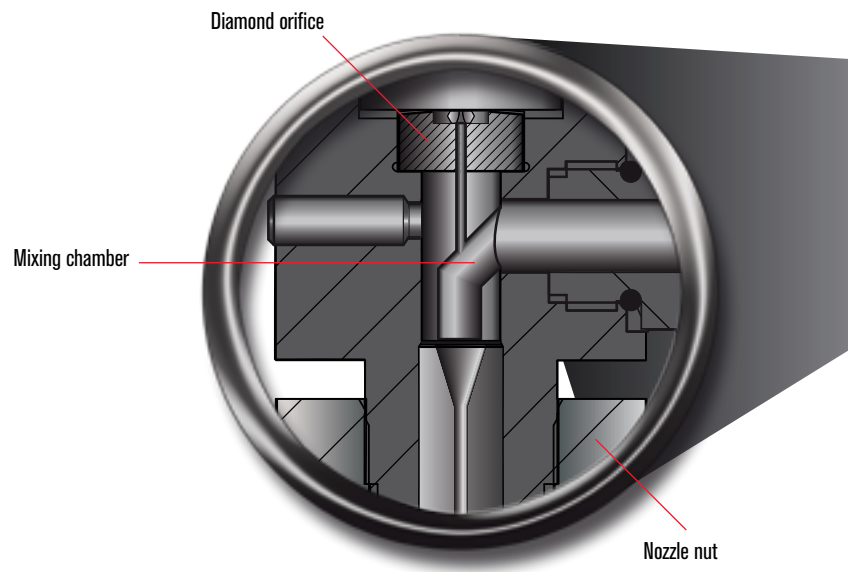

DiaLine shown with 3/16" (0.5 cm) inlet, 3" (7.6 cm) nozzle, and protective spray guard.

DiaLine shown with 3/8" (1 cm) Inlet, 3" (7.6 cm) nozzle, protective spray guard, and swivel adapter.

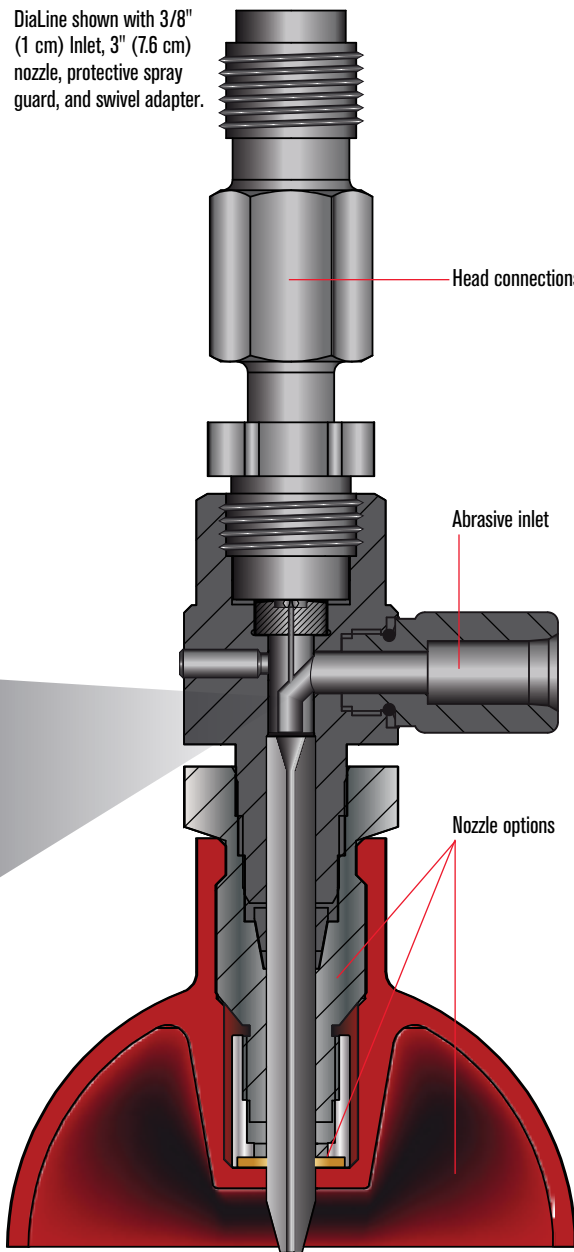

What we've improved

Head connections

- New adapter connections provide the ability to rotate the abrasive inlet, enabling perfect placement
- Range of adapter configurations available to easily mount DiaLine to any waterjet system

Abrasive inlet

- Optional 3/16" (0.5 cm) abrasive inlet enables simple connection to smaller abrasive feed lines
- Optional dual inlet (not shown) makes vacuum-assisted cutting possible for low-pressure piercing of brittle materials

Nozzle options

- Three nozzle nut options allow for custom cutting head configurations (standard, 3" [7.6 cm], and 4" [10.2 cm] guards)
- Nozzle guard design significantly reduces wear and protects the cutting head
- Second carbide-lined nut provides maximum protection and wear resistance (replaceable)



DiaLine vs standard ruby head

- One DiaLine orifice lasts as long as 30 ruby orifices
- Save 12.5% on hourly operating cost with DiaLine
- Reduce orifice-related downtime and purchase frequency by 3,000%
- Increase nozzle life by 15% through 1,200 hours of perfectly aligned cutting stream to the nozzles

Operating cost

Operating cost	
Ruby	\$1.79/hr.
DiaLine	\$1.57/hr.

Average life (in hours)

Average life (in hours)		
	Ruby	DiaLine
Orifices	40	1,200
Nozzles	60	70

Completely customizable

When choosing a DiaLine, you are not limited to one style or configuration. DiaLine allows you to customize your cutting head to meet the specific needs of your operation. Not only will you have a cutting head that exceeds all quality expectations, but a cutting head that also works seamlessly with your system and allows you to operate at peak performance.

Build your DiaLine

Choose your abrasive body

Choose from single dual-inlet abrasive bodies.

Choose your inlet

Choose from 3/8" (1 cm) (Standard) or 3/16" (0.5 cm) for smaller abrasive feed lines.

Choose your nozzle nut

Choose from the standard, 3" (7.6 cm), and 4" (10.2 cm) nozzle nut.

Complete the package

Choose your connection

Choose from standard or swivel adapters for any system.

Choose your orifice

Choose from diamond (.008-.018) or ruby (.004-.020) orifices.

Choose your protection

Choose from 1/4" (0.6 cm) or 3/8" (1 cm) thimble filters to add protection and take advantage of our 600 hour extended warranty.



For purchasing information, or to download the DiaLine buyers' guide, visit accustream.com

Hypertherm, AccuStream, and DiaLine are trademarks of Hypertherm Inc. and may be registered in the United States and/or other countries.

One of Hypertherm's long-standing core values is a focus on minimizing our impact on the environment. Doing so is critical to our, and our customers' success. We are always striving to become better environmental stewards; it is a process we care deeply about.

© 9/2016 Hypertherm Inc. Revision 1
896730

