

R O W A N



ARNE & CARLOS
TINE

ZB305-00005-ENP



ARNE & CARLOS

TINE



SKILL LEVEL



SIZE

To fit bust/chest (cm/in)

81-86	91-97	102-107	112-117	122-127	132-137	142-147	152-157
32-34	36-38	40-42	44-46	48-50	52-54	56-58	60-62
Actual bust/chest measurement of garment							
100	109	120	129	140	149	160	169
39¼	43	47¼	50¾	55	58½	63	66½

YARN

Norwegian Wool (50gm)

A Cloud Dancer 014

3	3	3	4	4	4	4	5
---	---	---	---	---	---	---	---

B Golden Nugget 012

1	1	1	1	1	1	1	1
---	---	---	---	---	---	---	---

C Ribbon Red 018

2	2	2	2	2	2	3	3
---	---	---	---	---	---	---	---

D Daphne 011

6	6	7	8	8	9	10	11
---	---	---	---	---	---	----	----

NEEDLES

1 pair 3mm (no 11) (US 2/3) needles

1 pair 3¾mm (no 9) (US 5) needles

TENSION

25 sts and 24 rows to 10 cm measured over patterned st st, 22 sts and 28 rows to 10 cm measured over plain st st, 19 sts and 35 rows to 10 cm measured over moss st, all using 3¾mm (US 5) needles.

BACK

Using 3mm (US 2/3) needles and yarn C cast on 106 [114: 126: 138: 150: 158: 170: 182] sts.

Row 1 (RS): K2, *P2, K2, rep from * to end.

Row 2: P2, *K2, P2, rep from * to end.

These 2 rows form rib.

Cont in rib until back meas 4 cm, dec 2 [0: 0: 2: 2: 0: 0: 2] sts evenly across last row and ending with **WS** facing for next row.

104 [114: 126: 136: 148: 158: 170: 180] sts.

Change to 3¾mm (US 5) needles.

Next Row: Using yarn C, purl.

Break off yarn C.

Join yarn B and beg with a K row, work 2 rows in st st.

Break off yarn B.

Join yarn D and cont in st st, inc 1 st at each end of 27th [29th: 31st: 33rd: 35th: 35th: 35th: 37th] and foll 28th [30th: 32nd: 34th: 36th: 36th: 38th: 38th] row, then on foll 30th [32nd: 34th: 36th: 36th: 38th: 38th: 40th] row.

110 [120: 132: 142: 154: 164: 176: 186] sts.

Work 0 [0: 0: 0: 0: 4: 8: 10] rows in st st, ending with **WS** facing for next row. (Work should meas approx. 35.5 [37.5: 39.5: 41.5: 43.5: 45.5: 47.5: 49.5] cm.)

Next row (WS): P10 [8: 7: 5: 4: 9: 8: 6], M1P, (P6 [7: 7: 7: 7: 7: 7], M1P) 15 [15: 17: 19: 21: 21: 23: 25] times, P to end. 126 [136: 150: 162: 176: 186: 200: 212] sts.

Beg and ending rows as indicated and using the **fairisle** technique as described on the information page, working the 40-st patt rep 3 [3: 3: 4: 4: 4: 5: 5] times across each row, work 42 rows from chart A, ending with RS facing for next row.

Next Row: Using yarn A, knit.

Next Row: Using yarn D, knit.

Break off yarn D. Change to yarn A.

Next row (RS): K4 [5: 4: 6: 5: 6: 5: 7], K2tog, (K2, K2tog) 29 [31: 35: 37: 41: 43: 47: 49] times, K to end. 96 [104: 114: 124: 134: 142: 152: 162] sts. **

Next row (WS): *K1, P1, rep from * to end.

Next row: *P1, K1, rep from * to end.

Last 2 rows form moss st.

Rep last 2 rows a further 8 times, then the first of these 2 rows once more.

K 1 row.

Change to yarn B. Break off yarn A.

Shape back neck

Next row (WS): P36 [39: 43: 48: 52: 55: 60: 64] and turn, leaving rem sts on a holder.

Work each side of neck separately.

Next row (RS): P2tog 1 [0: 0: 1: 1: 0: 1: 1] times, (K2tog, P1) 0 [1: 1: 0: 0: 1: 0: 0] times, *K1, P1, rep from * to end.

35 [38: 42: 47: 51: 54: 59: 63] sts.

Last row sets **position** of moss st.

Cont in moss st as now set by last row, dec 1 st at beg of the 2nd and the foll alt row, ending with **WS** facing for next row. 33 [36: 40: 45: 49: 52: 57: 61] sts.

P 1 row.

Change to yarn C. Break off yarn B.

Next row (RS): K2tog, K to end. 32 [35: 39: 44: 48: 51: 56: 60] sts.

Next row: *K1, P1, rep from * to last 0 [1: 1: 0: 0: 1: 0: 0] sts, K0 [1: 1: 0: 0: 1: 0: 0].

Cont in moss st as now set dec 1 st at beg of the next and the foll alt row.

30 [33: 37: 42: 46: 49: 54: 58] sts.

Work 1 more row in moss st.

K 1 row.

Cast off purlwise (on **WS**).

With **WS** facing, slip centre 24 [26: 28: 28: 30: 32: 32: 34] sts onto a holder (for neckband), rejoin yarn B to rem sts and P to end.

Complete to match first side, reversing shapings.

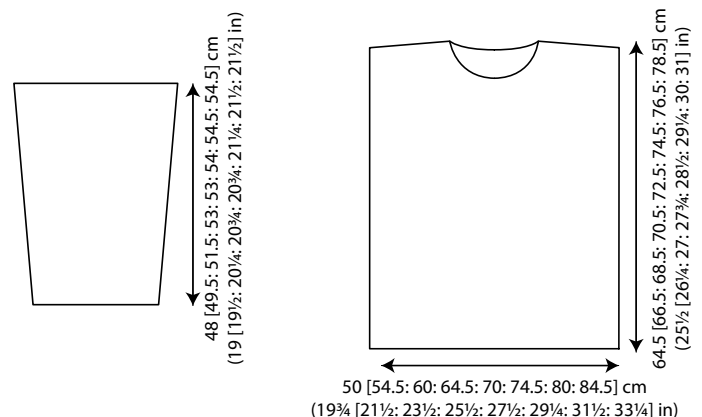

FRONT

Work as given for back to **, then work next 4 [4:2:2:0:0:0:0] rows in moss as given for back, ending with **WS** facing for next row.

96 [104: 114: 124: 134: 142: 152: 162] sts.

Shape front neck

Next row (WS): (K1, P1) 19 [21: 23: 26: 28: 30: 32: 34] times, K1 [0: 1: 0: 0: 0: 1: 1] and turn, leaving rem sts on a holder. 39 [42: 47: 52: 56: 60: 65: 69] sts. Work each side of neck separately.

Cont in moss st as now set, dec 1 st at neck edge of next 3 rows then on foll 5 [5: 6: 6: 7: 7: 7] alt rows. 31 [34: 38: 43: 46: 50: 55: 59] sts.

Work 1 row in moss st.

Next row (RS): K2tog 1 [1: 1: 1: 0: 1: 1: 1] time, K to end. 30 [33: 37: 42: 46: 49: 54: 58] sts.

Change to yarn B. Break off yarn A.

P 1 row.

Next row: P0 [1: 1: 0: 0: 1: 0: 0], *K1, P1, rep from * to end.

Cont in moss st as now set for 4 rows, ending with **WS** facing for next row.

P 1 row.

Change to yarn C. Break off yarn B.

K 1 row.

Next row (WS): *K1, P1, rep from * to last 0 [1: 1: 0: 0: 1: 0: 0] sts, K0 [1: 1: 0: 0: 1: 0: 0].

Cont in moss st as now set for a further 4 rows, ending with RS facing for next row.

K 1 row.

Cast off purlwise on **WS**.

With **WS** facing, slip centre 18 [20: 20: 20: 22: 22: 22: 24] sts onto a holder (for neckband), rejoin yarn A to rem sts and moss st to end.

Complete to match first side, reversing shapings.

SLEEVES

Using 3mm (US 2/3) needles and yarn C cast on 44 [47: 47: 50: 53: 56: 56: 56] sts.

Row 1 (RS): K1, *K2, P1, rep from * to last st, K1.

Row 2: K1, *K1, P2, rep from * to last st, K1.

These 2 rows form rib.

Cont in rib until sleeve meas 4 cm, - [dec: inc: -: dec: -: -: inc] - [1: 1: -: 1: -: -: 2] sts evenly across last row and ending with **WS** facing for next row.

44 [46: 48: 50: 52: 56: 56: 58] sts.

Change to 3¼mm (US 5) needles.

Next Row: Using yarn C, purl.

Join yarn B and beg with a K row work 2 rows in st st.

Break off yarn B.

Join yarn D and cont in st st, inc 1 st at each end of 3rd [3rd: 3rd: 3rd: 3rd: next: next: next] and 10 [14: 20: 21: 21: 22: 5: 7] foll 4th [4th: 4th: 4th: 4th: 4th: alt: alt] rows, then on 5 [3: -: -: -: -: 20: 19] foll 6th [6th: -: -: -: -: 4th: 4th] rows. 76 [82: 90: 94: 96: 102: 108: 112] sts. (Sleeve should meas approx. 31 [32.5: 34.5: 36: 36: 37: 37.5: 37.5] cm)

Next row (WS): P6 [7: 6: 8: 8: 5: 8: 3], P2tog, (P5 [4: 5: 5: 4: 5: 5: 5], P2tog) 9 [11: 11: 11: 13: 13: 13: 15] times, P to end. 66 [70: 78: 82: 82: 88: 94: 96] sts.

Change to yarn A.

Next row: *K1, P1, rep from * to end.

Next row: *P1, K1, rep from * to end.

The last 2 rows form moss st.

Cont in moss st inc 1 st at each end of the 3rd [3rd: 3rd: next: next: next: next: next] and 2 [2: 2: 2: 1: 4: 4: 4] foll 6th [6th: 6th: 4th: 2nd: 4th: 4th: 4th] rows, then on - [-: -: 1: 3: -: -: -] foll - [-: -: 6th: 4th: -: -: -] rows, taking inc sts into patt. 72 [76: 84: 90: 92: 98: 104: 106] sts.

Work 2 [2: 2: 2: 0: 0: 0] rows in moss st.

Next row (WS): P5 [4: 5: 5: 3: 6: 6: 4], M1P, (P3, M1P) 21 [23: 25: 27: 29: 29: 31: 33] times, P to end. 94 [100: 110: 118: 122: 128: 136: 140] sts.

Beg and ending rows as indicated and repeating the 8 st patt rep 11 [12: 13: 14: 15: 16: 17: 17] times across each row, work rows 1 to 15 from chart B, inc 1 st at each end of 3rd [3rd: 3rd: 3rd: next: 3rd: 3rd: 3rd] and the 2 [2: 2: 2: 2: 3: 3: 3] foll 6th [6th: 6th: 6th: 4th: 4th: 4th: 4th] rows, then on 0 [0: 0: 0: 1: 0: 0: 0] foll 6th rows, taking inc sts into patt and ending with **WS** facing for next row. 100 [106: 116: 124: 130: 136: 144: 148] sts.

Break off yarn D.

Next row (WS): Using yarn A, P3 [6: 3: 3: 2: 5: 1: 3], P2tog, (P2, P2tog) 23 [23: 27: 29: 31: 31: 35: 35] times, P to end.

76 [82: 88: 94: 98: 104: 108: 112] sts.

Change to yarn B. Break off yarn A.

K 1 row.

Next row (WS): *K1, P1, rep from * to end.

Next row: *P1, K1, rep from * to end.

These last 2 rows form moss st.

Rep last 2 rows once more, then first of these 2 rows once more, ending with RS facing for next row.

K 1 row.

Change to yarn C. Break off yarn B.

P 1 row.

Next row (RS): *K1, P1, rep from * to end.

Next row: *P1, K1, rep from * to end.

Rep last 2 rows once more, then first of these 2 rows once more.

P 1 row.

Cast off.

MAKING UP

Press as described on the information page.

Join right shoulder seam using back stitch, or mattress stitch if preferred.

Neckband

With RS facing, using 3mm (US 2/3) needles and yarn B pick up and knit 18 [19: 21: 21: 22: 23: 23: 23] sts down left side of front neck, work across 18 [20: 20: 20: 22: 22: 22: 24] sts from front holder as folls: K3 [3: 3: 3: 4: 4: 4: 3], M1, (K4 [5: 5: 5: 5: 5: 6], M1) 3 times, K3 [2: 2: 2: 3: 3: 3: 3], pick up and knit 18 [19: 21: 21: 22: 23: 23: 23] sts up right side of front neck, and 10 sts down right side of back neck, K across 24 [26: 28: 28: 30: 32: 32: 34] sts from back holder as folls: K5 [3: 4: 4: 3: 4: 4: 5], M1, (K5 [4: 7: 7: 5: 5: 5: 5], M1) 3 [5: 3: 3: 5: 5: 5: 5] times, K4 [3: 3: 3: 2: 3: 3: 4], then pick up and knit 10 sts up left side of back neck.

106 [114: 118: 118: 126: 130: 130: 134] sts.

Beg with row 2, work 1 row in rib as given for back.

Change to yarn C. Break off yarn B.

Cont in rib for a further 10 rows using yarn C.

Cast off in rib.

Join left shoulder and neckband seam.

Mark points along side seam edges 20 [21.5: 23: 24.5: 26: 27.5: 28.5: 29.5] cm either side of shoulder seams (to denote base of armhole openings). See information page for finishing instructions, setting in sleeves using the straight cast-off method.

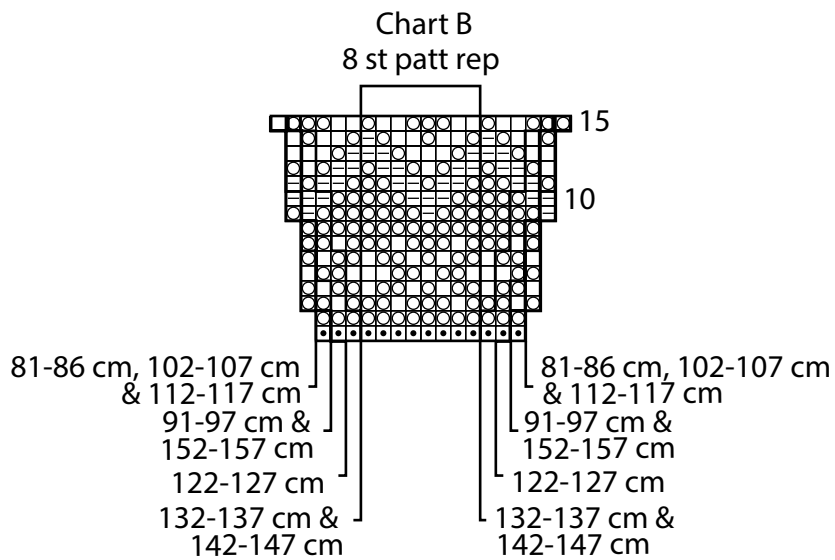
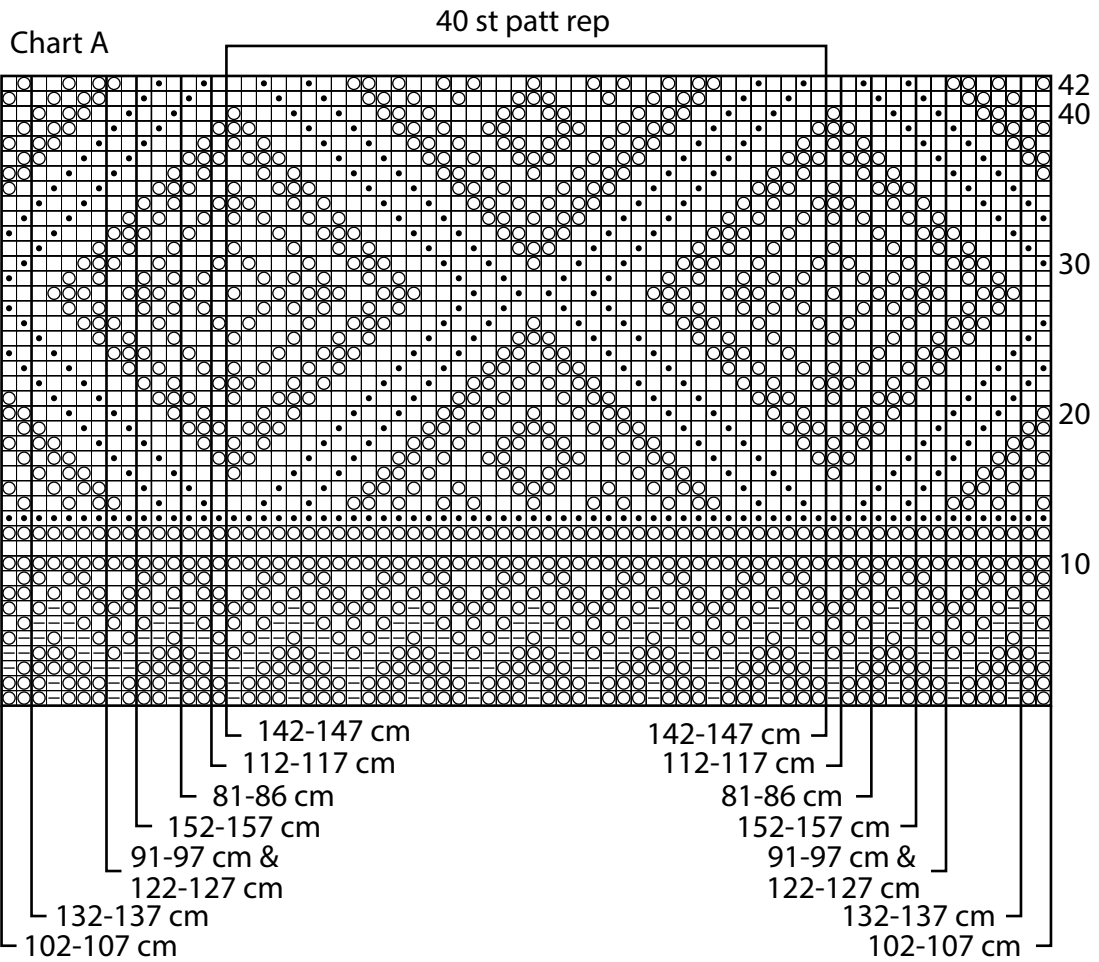

Key

- K on RS, P on WS in yarn A
- ▤ P on RS, K on WS in yarn A
- ▥ K on RS, P on WS in yarn D
- ▧ P on RS, K on WS in yarn D

TENSION

Obtaining the correct tension is perhaps the single factor which can make the difference between a successful garment and a disastrous one. It controls both the shape and size of an article, so any variation, however slight, can distort the finished garment. Different designers feature in our books and it is **their** tension, given at the **start** of each pattern, which you must match. We recommend that you knit a square in pattern and/or stocking stitch (depending on the pattern instructions) of perhaps 5 - 10 more stitches and 5 - 10 more rows than those given in the tension note. Mark out the central 10cm square with pins. If you have too many stitches to 10cm try again using thicker needles, if you have too few stitches to 10cm try again using finer needles. Once you have achieved the correct tension your garment will be knitted to the measurements indicated in the size diagram shown at the end of the pattern.

CHART NOTE

Many of the patterns in the book are worked from charts. Each square on a chart represents a stitch and each line of squares a row of knitting. Each colour used is given a different letter and these are shown in the **materials** section, or in the **key** alongside the chart of each pattern. When working from the charts, read odd rows (RS) from right to left and even rows (WS) from left to right, unless otherwise stated. When working lace from a chart it is important to note that all but the largest size may have to alter the first and last few stitches in order not to lose or gain stitches over the row.

WORKING A LACE PATTERN

When working a lace pattern it is important to remember that if you are unable to work both the increase and corresponding decrease and vice versa, the stitches should be worked in stocking stitch.

KNITTING WITH COLOUR

There are two main methods of working colour into a knitted fabric: **Intarsia** and **Fairisle** techniques. The first method produces a single thickness of fabric and is usually used where a colour is only required in a particular area of a row and does not form a repeating pattern across the row, as in the fairisle technique.

Fairisle type knitting: When two or three colours are worked repeatedly across a row, strand the yarn **not** in use loosely behind the stitches being worked. If you are working with more than two colours, treat the “floating” yarns as if they were one yarn and always spread the stitches to their correct width to keep them elastic. It is advisable not to carry the stranded or “floating” yarns over more than three stitches at a time, but to weave them under and over the colour you are working. The “floating” yarns are therefore caught at the back of the work.

Intarsia: The simplest way to do this is to cut short lengths of yarn for each motif or block of colour used in a row. Then joining in the various colours at the appropriate point on the row, link one colour to the next by twisting them around each other where they meet on the wrong side to avoid gaps. All ends can then either be darned along the colour join lines, as each motif is completed or then can be “knitted-in” to the fabric of the knitting as each colour is worked into the pattern. This is done in much the same way as “weaving-in” yarns when working the Fairisle technique and does save time darning-in ends. It is essential that the tension is noted for intarsia as this may vary from the stocking stitch if both are used in the same pattern.

FINISHING INSTRUCTIONS

After working for hours knitting a garment, it seems a great pity that many garments are spoiled because such little care is taken in the pressing and finishing process. Follow the text below for a truly professional-looking garment.

PRESSING

Block out each piece of knitting and following the instructions on the ball band press the garment pieces, omitting the ribs. Tip: Take special care to press the edges, as this will make sewing up both easier and neater. If the ball band indicates that the fabric is not to be pressed, then covering the blocked out fabric with a damp white cotton cloth and leaving it to stand will have the desired effect. Darn in all ends neatly along the selvage edge or a colour join, as appropriate.

STITCHING

When stitching the pieces together, remember to match areas of colour and texture very carefully where they meet. Use a seam stitch such as back stitch or mattress stitch for all main knitting seams and join all ribs and neckband with mattress stitch, unless otherwise stated.

CONSTRUCTION

Having completed the pattern instructions, join left shoulder and neckband seams as detailed above. Sew the top of the sleeve to the body of the garment using the method detailed in the pattern, referring to the appropriate guide:

Straight cast-off sleeves: Place centre of cast-off edge of sleeve to shoulder seam. Sew top of sleeve to body, using markers as guidelines where applicable.

Square set-in sleeves: Place centre of cast-off edge of sleeve to shoulder seam. Set sleeve head into armhole, the straight sides at top of sleeve to form a neat right-angle to cast-off sts at armhole on back and front.

Shallow set-in sleeves: Place centre of cast off edge of sleeve to shoulder seam. Match decreases at beg of armhole shaping to decreases at top of sleeve. Sew sleeve head into armhole, easing in shapings.

Set-in sleeves: Place centre of cast-off edge of sleeve to shoulder seam. Set in sleeve, easing sleeve head into armhole.

Join side and sleeve seams. Slip stitch pocket edgings and linings into place.

Sew on buttons to correspond with buttonholes. Ribbed welts and neckbands and any areas of garter stitch should not be pressed.

INFORMATION

ABBREVIATIONS

K	knit
P	purl
st(s)	stitch(es)
inc	increas(e)(ing)
dec	decreas(e)(ing)
st st	stocking stitch (1 row K , 1 row P)
g st	garter stitch (K every row)
beg	begin(ning)
fol	following
rem	remain(ing)
rev st st	reverse stocking stitch (1 row P, 1 row K)
rep	repeat
alt	alternate
cont	continue
patt	pattern
tog	together
mm	millimetres
cm	centimetres
in(s)	inch(es)
RS	right side
WS	wrong side
sl 1	slip one stitch
psso	pass slipped stitch over
p2sso	pass 2 slipped stitches over
tbl	through back of loop
M1	make one stitch by picking up horizontal loop before next stitch and knitting into back of it
M1P	make one stitch by picking up horizontal loop before next stitch and purling into back of it
yfwd	yarn forward
yrn	yarn round needle
meas	measures
0	no stitches, times or rows
-	no stitches, times or rows for that size
yon	yarn over needle
yfrn	yarn forward round needle
wyib	with yarn at back

CROCHET TERMS

UK crochet terms and abbreviations have been used throughout. The list below gives the US equivalent where they vary.

ABBREV.	UK	US
dc (sc)	double crochet	(single crochet)
htr (hdc)	half treble	(half double crochet)
tr (dc)	treble	(double crochet)
dtr (tr)	double treble	(treble)

EXPERIENCE RATING - for guidance only

● = Beginner Techniques

For the beginner knitter, basic garment shaping and straight forward stitch technique.

●● = Simple Techniques

Simple straight forward knitting, introducing various, shaping techniques and garments.

●●● = Experienced Techniques

For the more experienced knitter, using more advanced shaping techniques at the same time as colourwork or more advanced stitch techniques.

●●●● = Advanced Techniques

Advanced techniques used, using advanced stitches and garment shaping along with more challenging techniques

BUTTONS, BEADS AND RIBBONS USED IN THIS MAGAZINE ARE SOURCED FROM:



Bedecked Haberdashery

The Coach House
Barningham Park
Richmond
North Yorkshire
DL11 7DW
TEL: +44 (0) 1833 621 451
eMail: thegirls@bedecked.co.uk
Web: www.bedecked.co.uk



Website: www.debbieabrahams.com
Email: beads@debbieabrahams.com
Tel: 0115 9607991

Groves & Banks

Eastern Bypass
Thame
Oxfordshire
OX9 3FU
eMail: groves@stockistenquiries.co.uk
Web: www.grovesltd.co.uk

WASH CARE INFORMATION

Below are the symbols you are likely to see and a brief explanation of each.

MACHINE WASH SYMBOLS



Machine Wash,
Cold



Machine Wash,
Cold, Gentle



Machine Wash,
Warm



Machine Wash,
Warm, Gentle

HAND WASH SYMBOLS



Do Not Wash



Hand Wash,
Normal



Hand Wash,
Cold



Hand Wash,
Warm

DRY CLEAN SYMBOLS



Do Not
Dry Clean



Dry
Clean



Dry Clean, in
Certain Solvents,
Consult Cleaner



Dry Clean,
Any Solvent

IRONING SYMBOLS



Do Not
Iron



Iron Low
Heat



Iron Medium
Heat

DO NOT BLEACH SYMBOL



Do Not
Bleach

DRYING SYMBOLS



Do Not
Tumble Dry



Tumble Dry,
Gentle, Low
Heat



Dry Flat
in Shade



Do Not
Wring

SIZING GUIDE

When you knit and wear a Rowan design we want you to look and feel fabulous. This all starts with the size and fit of the design you choose. We have recently increased our size range to help you achieve the best fit for your knitwear.

Our womenswear sizes range from 28” (71cm) through to 62” (157cm) chest. Whilst our menswear and unisex sizes range from 32” (81cm) to 62” (157cm).

The Dimensions in the charts below are body measurements, not garment dimensions, therefore please refer to the measuring guide to help you to determine which is the best size for you to knit.

STANDARD WOMENS SIZING GUIDE

The sizing within this chart is also based on the larger size within the range.

To fit chest:	28 - 30	32 - 34	36 - 38	40 - 42	44 - 46	48 - 50	52 - 54	56 - 58	60 - 62	inches
	71 - 76	81 - 86	91 - 97	102 - 107	112 - 117	122 - 127	132 - 137	142 - 147	152 - 157	cm
To fit waist:	20 - 22	24 - 26	28 - 30	32 - 34	36 - 38	40 - 42	44 - 46	48 - 50	52 - 54	inches
	51 - 56	61 - 66	71 - 76	81 - 86	91 - 97	102 - 107	112 - 117	122 - 127	132 - 137	cm
To fit hips:	30 - 32	34 - 36	38 - 40	42 - 44	46 - 48	50 - 52	54 - 56	58 - 60	62 - 64	inches
	76 - 81	86 - 91	97 - 102	107 - 112	117 - 122	127 - 132	137 - 142	147 - 152	157 - 163	cm

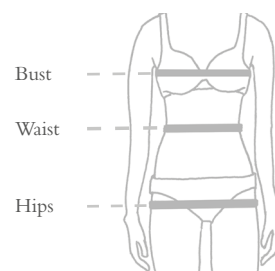

STANDARD MENS AND UNISEX SIZING GUIDE

The sizing within this chart is also based on the larger size within the range.

To fit chest:	32 - 34	36 - 38	40 - 42	44 - 46	48 - 50	52 - 54	56 - 58	60 - 62	inches
	81 - 86	91 - 97	102 - 107	112 - 117	122 - 127	132 - 137	142 - 147	152 - 157	cm
To fit waist:	24 - 26	28 - 30	32 - 34	36 - 38	40 - 42	44 - 46	48 - 50	52 - 54	inches
	61 - 66	71 - 76	81 - 86	91 - 97	102 - 107	112 - 117	122 - 127	132 - 137	cm

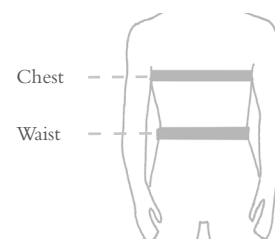

SIZING GUIDE

SIZING & SIZE DIAGRAM NOTE

The instructions are given for the smallest size. Where they vary, work the figures in brackets for the larger sizes. One set of figures refers to all sizes. Included with most patterns is a size diagram, see image opposite of the finished garment and its dimensions. The measurement shown at the bottom of each size diagram shows the garment width. The size diagram will also indicate how the garment is constructed, for example if the garment has a drop shoulder, this will be reflected in the drawing. To help you choose the size of garment to knit please refer to the sizing guide. Generally in the majority of designs the welt width (at the cast on edge of the garment) is the same width as the chest. If you don't want to measure yourself, note the size of a similar shaped garment that you own and compare it with the size diagram given at the end of the pattern.

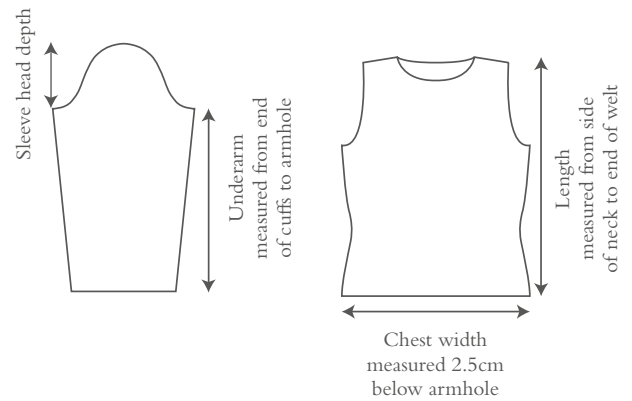

MEASURING GUIDE

For maximum comfort and to ensure the correct fit when choosing a size to knit, please follow the tips below when checking your size. Measure yourself close to your body, over your underwear and don't pull the tape measure too tight!

Bust/chest | measure around the fullest part of the bust/chest and across the shoulder blades.

Waist | measure around the natural waistline, just above the hip bone.

Hips | measure around the fullest part of the bottom.

Finally, once you have decided which size is best for you, please ensure that you achieve the tension required for the design you wish to knit.

Remember if your tension is too loose, your garment will be bigger than the pattern size and you may use more yarn. If your tension is too tight, your garment could be smaller than the pattern size and you will have yarn left over.

Furthermore if your tension is incorrect, the handle of your fabric will be too stiff or floppy and will not fit properly. It really does make sense to check your tension before starting every project.