



Betwixtmas Shawl 2022

Designed for Black Sheep Wools by Urth Yarns

Horizontal ribbons of multicolour 'woven' linen stitch alternate with ribbed rectangular blocks in three solid colours, in this right-triangle shaped shawl. I-cord edges and strong vertical rib lines on the reverse side make a lively visual contrast that knits up fairly quickly in easy-to-remember stitches.

Materials Urth Cotton DK, MC 100g, CC1 50g, CC2 50g
Amy MC Snow, CC1 *Coral*, CC2 *Glacier*

Dimensions 45"/114 cm wingspan, 41"/104 cm straight

edge, 30.5"/78 cm wide at finish edge,
unblocked

Needles 4 mm, preferably circular;
or size needed to obtain gauge

Notions Tapestry needle, stitch markers as needed

Gauge 24 sts x 24 rows in 3x1 rib stitch = 4"/10 cm
unblocked. Gauge is not crucial for size, but it is
for yarn consumption. The CC colours
will be almost entirely used.

Skill level Easy to Intermediate

Techniques Decreasing, increasing,
slip stitches, I-cord



urth yarns

Abbreviations

Bet – Between

BO – Bind off

CC1 – Contrast colour 1

CC2 – Contrast colour 2

CO – Cast on

EOR – End of Row

K – Knit

K2tog – Knit 2 sts together

MC – Main colour

M1 – Make 1 stitch through the bar below (increase)

Ndl(s) – Needle(s)

P – Purl

Rep – Repeat

RS – Right Side

Sl – Slip

St(s) – Stitch(es)

Tog – Together

WS – Wrong Side

Wyib – With yarn in back

Wyif – With yarn in front

Special Stitches & Techniques

The two stitch patterns repeat in a 20-row sequence. The stitch pattern changes between the 10 row segments of 3x1 Rib and the 10 row segments of Linen Stitch when beginning a WS row. This change is easier to do along the straight edge instead of the beginning of the RS row, which always increases 1 st after the first 3 I-cord sts.

Linen Stitch

(2 st rep x 2 rows)

WS: *Sl1 wyib, p1*, rep bet *-*.

RS: *Sl1 wyif, k1*, rep bet *-*.

3x1 Rib

(4 st repeat x 2 rows)

WS: *P3, k1*, rep bet *-*.

RS: *P1, k3*, rep bet *-*.

3 St I-Cord Edges, all rows:

Knit the first 3 sts, slip the last 3 sts with yarn in front.

3 St I-Cord BO: CO 3 sts, *k2, k2tog.

Move the three sts back to the left (working) ndl*, rep bet *-* until 3 sts remain, BO.

Schematic

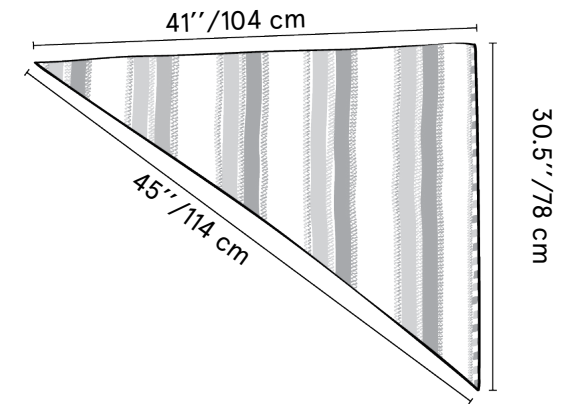

Construction Notes

The three yarn colours repeat in a 60-row sequence, not including the first 14 setup rows. The following sequence is one repeat of the colour sequence, and three repeats of the stitch sequence. Refer to the Chart for the rows within the red repeat outline:

2 rows each MC, CC1, MC, CC1, MC;
total 10 Rows in **Linen St**

10 rows CC2 in **3x1 Rib**

2 rows each MC, CC2, MC, CC2, MC;
total 10 rows in **Linen St**

10 rows MC in **3x1 Rib**

2 rows each MC, CC1, MC, CC2, MC;
total 10 rows in **Linen St**

10 rows CC1 in **3x1 Rib**

Each RS row starts with 3 knit sts for the I-cord, followed by making one stitch through the loop below, for a 1 st increase every two rows for the entire shawl starting with Row 4.

Each WS row starting from Row 15 with the first yarn colour change begins with a yarn wrap along the straight edge (right-hand side with WS facing). Wrap the working yarn around other two yarns to catch them within the I-cord. Wrap once in either direction which feels more comfortable, as long as the two yarns not being worked are caught in the working yarn wrap.

Take care that the yarns are not pulled too tightly so that the edge lays flat. This yarn wrap happens on the RS of the work with the WS facing, but encases the yarns so they are carried within the I-cord and not visible from either side. The final step of knitting the 3 sts of the I-cord secures the yarns in place.

For the Rows beyond Row 74: Work the 3x1 Rib repeat, in full or partially, as it works out stitchwise in the repeat pattern sequence. There are 2 variations of where in the 4-st, 10-row rep will the 4 sts end, most easily seen when

looking at the Chart. Since there are three color section repeats, there is another 60 rows to get the full 120-row repeat not included in the Chart.

Pattern

Even numbered rows are **RS**.

Odd numbered rows are **WS**.

Note: CO sts may be worked provisionally in a waste yarn if preferred, then Row 1 worked in CC1.

Provisional sts are grafted together during finishing. The Chart shows setup rows and one full repeat, not the entire Shawl.

Using CC1, CO 7 sts. Work the following setup rows also using CC1:

Row 1 (WS): K7.

Row 2 (RS): K3, p1, sl3 wyif.

Row 3: K4, sl3 wyif.

Row 4: K3, m1, p1, sl3 wyif. 8 sts

Row 5: K4, p1, sl3 wyif.

Row 6: K3, m1, k1, p1, sl3 wyif. 9 sts

Row 7: K4, p2, sl3 wyif.

Row 8: K3, m1, k2, p1, sl3 wyif. 10 sts

Row 9: K4, p3, sl3 wyif.

Row 10: K3, m1, k3, p1, sl3 wyif. 11 sts

Row 11: K4, p4, sl3 wyif.

Row 12: K3, m1, k4, p1, sl3 wyif. 12 sts

Row 13: K4, p5, sl3 wyif.

Row 14: K3, m1, k5, p1, sl3 wyif. 13 sts

The 60-row colour repeat sequence begins, as outlined in red in the Chart.

First Linen Stitch segment alternating MC and CC1

Row 15 (WS): Using MC, k4, *sl1 wyib, p1*, rep bet *-* to last 3 sts, sl3 wyif.

Row 16 (RS): K3, m1, *sl1 wyif, k1*, rep bet *-* to last 4 sts, p1, sl3 wyif. 14 sts

Row 17: Using CC1, k4, *sl1 wyib, p1*, rep bet *-* to last 4 sts, sl1 wyib, sl3 wyif.

Row 18: K3, m1, k1, *sl1 wyif, k1*, rep bet *-* to last 4 sts, p1, sl3 wyif. 15 sts

Row 19: Using MC, k4, *sl1 wyib, p1*, rep bet *-* to last 3 sts, sl3 wyif.

Row 20: K3, m1, *sl1 wyif, k1*, rep bet *-* to last 4 sts, p1, sl3 wyif. 16 sts

Row 21: Using CC1, k4, *sl1 wyib, p1*, rep bet *-* to last 4 sts, sl1 wyib, sl3 wyif.

Row 22: K3, m1, k1, *sl1 wyif, k1*, rep bet *-* to last 4 sts, p1, sl3 wyif. 17 sts

Row 23: Using MC, k4, *sl1 wyib, p1*, rep bet *-* to last 3 sts, sl3 wyif.

Row 24: K3, m1, *sl1 wyif, k1*, rep bet *-* to last 4 sts, p1, sl3 wyif. 18 sts

First 3x1 Rib segment, all rows in CC2

Row 25 (WS): K4, *p3, k1*, rep bet *-* to last 6 sts, p3, sl3 wyif.

Row 26 (RS): K3, m1, k3, *p1, k3*, rep bet *-* to last 4 sts, p1, sl3 wyif. 19 sts

Row 27: K4, *p3, k1*, rep bet *-* to last 3 sts, sl3 wyif.

Row 28: K3, m1, *p1, k3*, rep bet *-* to last 4 sts, p1, sl3 wyif. 20 sts

Row 29: K4, *p3, k1*, rep bet *-* to last 4 sts, p1, sl3 wyif.

Row 30: K3, m1, k1, *p1, k3*, rep bet *-* to last 4 sts, p1, sl3 wyif. 21 sts

Row 31: K4, *p3, k1*, rep bet *-* to last 5 sts, p2, sl3 wyif.

Row 32: K3, m1, k2, *p1, k3*, rep bet *-* to last 4 sts, p1, sl3 wyif. 22 sts

Row 33: K4, *p3, k1*, rep bet *-* to last 6 sts, p3, sl3 wyif.

Row 34: K3, m1, k3, *p1, k3*, rep bet *-* to last 4 sts, p1, sl3 wyif. 23 sts

Second Linen Stitch segment alternating MC and CC2

Row 35 (WS): K4, *sl1 wyib, p1*, rep bet *-* to last 3 sts, sl3 wyif.

Row 36 (RS): K3, m1, *sl1 wyif, k1*, rep bet *-* to last 4 sts, p1, sl3 wyif. 24 sts

Row 37: K4, *sl1 wyib, p1*, rep bet *-* to last 4 sts, sl1 wyib, sl3 wyif.

Row 38: K3, m1, k1, *sl1 wyif, k1*, rep bet *-* to last 4 sts, p1, sl3 wyif. 25 sts

Row 39: K4, *sl1 wyib, p1*, rep bet *-* to last 3 sts, sl3 wyif.

Row 40: K3, m1, k1, *sl1 wyif, k1*, rep bet *-* to last 4 sts, p1, sl3 wyif. 26 sts

Row 41: K4, *sl1 wyib, p1*, rep bet *-* to last 4 sts, sl1 wyib, sl3 wyif.

Row 42: K3, m1, k1, *sl1 wyif, k1*, rep bet *-* to last 4 sts, p1, sl3 wyif. 27 sts

Row 43: K4, *sl1 wyib, p1*, rep bet *-* to last 3 sts, sl3 wyif.

Row 44: K3, m1, *sl1 wyif, k1*, rep bet *-* to last 4 sts, p1, sl3 wyif. 28 sts

Second 3x1 Rib segment, all rows in MC

Row 45 (WS): K4, *p3, k1*, rep bet *-* to last 4 sts, p1, sl3 wyif.

Row 46 (RS): K3, m1, k1, *p1, k3*, rep bet *-* to last 4 sts, p1, sl3 wyif. 29 sts

Row 47: K4, *p3, k1*, rep bet *-* to last 5 sts, p2, sl3 wyif.

Row 48: K3, m1, k2, *p1, k3*, rep bet *-* to last 4 sts, p1, sl3 wyif. 30 sts

Row 49: K4, *p3, k1*, rep bet *-* to last 6 sts, p3, sl3 wyif.

Row 50: K3, m1, k3, *p1, k3*, rep bet *-* to last 4 sts, p1, sl3 wyif. 31 sts

Row 51: K4, *p3, k1*, rep bet *-* to last 3 sts, sl3 wyif.

Row 52: K3, m1, *p1, k3*, rep bet *-* to last 4 sts, p1, sl3 wyif. 32 sts

Row 53: K4, *p3, k1*, rep bet *-* to last 4 sts, p1, sl3 wyif.

Row 54: K3, m1, k1, *p1, k3*, rep bet *-* to last 4 sts, p1, sl3 wyif. 33 sts

Third Linen Stitch segment alternating MC, CC1 and CC2

Row 55 (WS): Using MC, K4, *sl1 wyib, p1*, rep bet *-* to last 3 sts, sl3 wyif.

Row 56 (RS): K3, m1, *sl1 wyif, k1*, rep bet *-* to last 4 sts, p1, sl3 wyif. 34 sts

Row 57: Using CC1, K4, *sl1 wyib, p1*, rep bet *-* to last 4 sts, sl1 wyib, sl3 wyif.

Row 58: K3, m1, k1, *sl1 wyif, k1*, rep bet *-* to last 4 sts, p1, sl3 wyif. 35 sts

Row 59: Using MC, K4, *sl1 wyib, p1*, rep bet *-* to last 3 sts, sl3 wyif.

Row 60: K3, m1, *sl1 wyif, k1*, rep bet *-* to last 4 sts, p1, sl3 wyif. 36 sts

Row 61: Using CC2, K4, *sl1 wyib, p1*, rep bet *-* to last 4 sts, sl1 wyib, sl3 wyif.

Row 62: K3, m1, k1, *sl1 wyif, k1*, rep bet *-* to last 4 sts, p1, sl3 wyif. 37 sts

Row 63: Using MC, K4, *sl1 wyib, p1*, rep bet *-* to last 3 sts, sl3 wyif.

Row 64: K3, m1, *sl1 wyif, k1*, rep bet *-* to last 4 sts, p1, sl3 wyif. 38 sts

Third 3x1 Rib segment, all rows in CC1

Row 65 (WS): K4, *p3, k1*, rep bet *-* to last 6 sts, p3, sl3 wyif.

Row 66 (RS): K3, m1, k3, *p1, k3*, rep bet *-* to last 4 sts, p1, sl3 wyif. 39 sts

Row 67: K4, *p3, k1*, rep bet *-* to last 3 sts, sl3 wyif.

Row 68: K3, m1, *p1, k3*, rep bet *-* to last 4 sts, p1, sl3 wyif. 40 sts

Row 69: K4, *p3, k1*, rep bet *-* to last 4 sts, p1, sl3 wyif.

Row 70: K3, m1, k1, *p1, k3*, rep bet *-* to last 4 sts, p1, sl3 wyif. 41 sts

Row 71: K4, *p3, k1*, rep bet *-* to last 5 sts, p2, sl3 wyif.

Row 72: K3, m1, k2, *p1, k3*, rep bet *-* to last 4 sts, p1, sl3 wyif. 42 sts

Row 73: K4, *p3, k1*, rep bet *-* to last 6 sts, p3, sl3 wyif.

Row 74: K3, m1, k3, *p1, k3*, rep bet *-* to last 4 sts, p1, sl3 wyif. 43 sts

Rows 75-254: Work Rows 15-74 three more times. 133 sts

Rows 255-304: Work Rows 15-64 once more. 158 sts

BO I-cord edge

From the WS, BO the 158 sts (see Special Stitches and Techniques above) in a three-colour sequence alternating MC with CC1 and CC2:

7 rows MC, *4 rows CC1, 4 rows MC, 4 rows CC2, 4 rows MC*, rep bet *-* (total 9 reps) to last 7 sts, work 7 rows in CC2, BO. Make sure to wrap yarns each time, as done for the straight edge I-cord.

Finishing

BO the 3 remaining I-cord stitches. Stitch together I-cord sts at the start of work, or leave them separate. Work in all loose yarns with a tapestry ndl. Lightly steam block if desired.

Chart

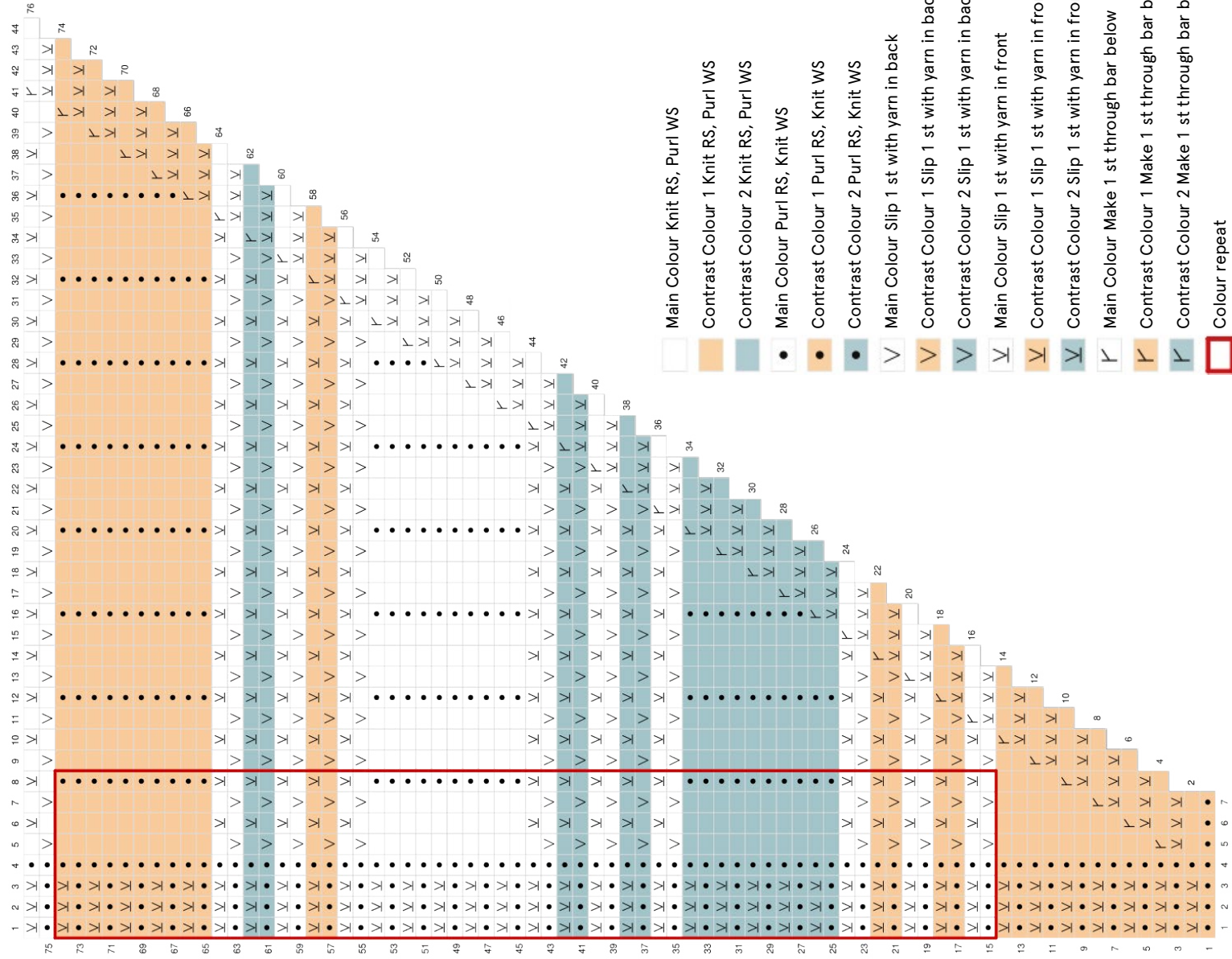

The Chart shows setup rows and one full repeat, not the entire Shawl.



Betwixtmas Shawl 2022

Designed for Black Sheep Wools by Urth Yarns

Stripes of Linen Stitch weave together one, two, or three colours, alternating with Horizontal ribbing for texture to create a relaxing, easy-to-make triangular shawl.

Materials Urth Cotton DK, MC 100g, CC1 50g, CC2 50g
Amy MC Snow, CC1 Coral, CC2 Glacier

Dimensions 33.5"/85 cm x 28.25"/72 cm x 44"/112 cm

Hook 4.50 mm;
or size needed to obtain gauge

Notions Tapestry needle, stitch markers

Gauge 11 sts x 19 rows in Linen Stitch = 4"/10 cm square
chain sts are not included in the stitch count

Skill level Easy to Intermediate

Techniques Chain, slip stitches, double crochet, half treble crochet, changing colours, crocheting into back loop only, decreasing



urth yarns

Abbreviations

This pattern uses UK crochet terms

Bet – Between

CC1 – Contrast colour 1

CC2 – Contrast colour 2

Ch – Chain

Dc – Double crochet

Dec – Decrease

EOR – End of row

Foll – Follow(-ing)

Htr – Half treble crochet

M – Marker

MC – Main colour

PM – Place marker

Rep – Repeat

RS – Right side

Sk – Skip

Ss – Slip stitch

Sp – Space

St(s) – Stitch(es)

WS – Wrong side

Yo – Yarn over

Special Stitches & Techniques

Changing colours

All colour changes are done at the end of the rows. When ready to change colour at the last stitch of the row, work as usual until the last yo of the stitch, lay the new colour over the hook to yo and draw through to change the working colour.

EOR Decrease (EOR dec)

Worked at the end of RS rows of Horizontal Rib stitch bands

Insert hook into back loop only of the next st, yo, pull up a loop, insert hook into both loops of the next st, yo, pull up a loop, yo, draw through all 3 loops on the hook.

Double crochet (dc)

Insert hook into stitch or space as specified in the pattern, yo, pull up a loop, yo, draw through 2 loops on the hook.

Half treble crochet (htr)

Yo, insert hook into stitch or space as specified in the pattern, yo, pull up a loop, yo, draw through all 3 loops on the hook.

Slip stitch (ss)

Insert hook into stitch or space as specified in the pattern, yo, draw through the loop on the hook.

Horizontal Rib stitch repeat

Row 1 (WS): Ch 1, 1 dc into 1st st, 1 htr into each sp to EOR, 1 htr into last st.

Row 2 (RS): Ch 1, (1 dc, ch 1, 1 dc blo) into 1st st, ch 1, *1 dc blo, ch 1* into each htr, rep bet * to last 2 sts, work EOR dec over last 2 sts.

Linen Stitch increase repeat

WS rows: Ch 1, dc into 1st st, dc into sp, *ch 1, sk next st, dc into next sp* rep bet * to last sp, ch 1, dc in last st, turn.

RS rows: Ch 1, dc into 1st st, ch 1, dc into sp, *ch 1, sk next st, dc into next sp* rep bet * to last sp, ch 1, sk next st, dc in last st, turn.

Construction Notes

The triangular shawl is worked in a relaxing Linen Stitch bands of one, two, or three colours, combined with Horizontal Ribbing.

2 bobbins of MC are required – split the MC skein into two 50g balls or work from both ends of a cake. Marking them with colourful stitch markers makes it easier to identify MC1 and MC2.

Always carry and work in the yarn that is not being used up the sides, by simply laying it on top of the hook when working the first or last st of the row to avoid having too many ends to work in later.

Chains are not included in the total stitch counts.

Schematic

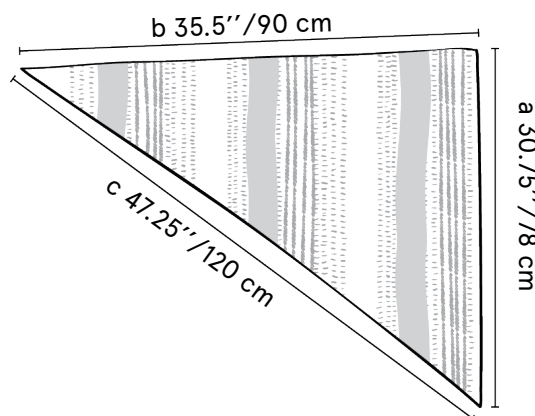

Pattern

1st colour band repeat

Set-up for 1-colour Linen Stitch (CC1)

Row 1 (CC1, WS): Using CC1, ch 3, htr in 3rd ch from the hook, turn. 1 st

Row 2 (RS): Ch 1, dc into 1st st, ch 1, dc into next ch, turn. 2 sts

Row 3: Ch 1, dc into 1st st, dc into sp, ch 1, dc in last st, turn. 3 sts

Row 4: Ch 1, dc into 1st st, ch1, dc into sp, ch 1, sk next st, dc in last st, turn. 3 sts

Row 5: Ch 1, dc into 1st st, dc into sp, ch 1, sk next st, dc into next sp, ch 1, dc into last st, turn. 4 sts

Row 6: Ch 1, dc into 1st st, ch 1, dc into sp, ch 1, sk next st, dc into next sp, ch 1, sk next st, dc in last st, turn. 4 sts

Row 7: Ch 1, dc into 1st st, dc into sp, *ch 1, sk next st, dc into sp* twice, ch 1, dc in last st, turn. 5 sts

Row 8: Ch 1, dc into 1st st, ch 1, dc into sp, *ch 1, sk next st, dc into next sp* twice, ch 1, sk next st, dc in last st, turn. 5 sts

Row 9: Ch 1, dc into 1st st, dc into sp, *ch 1, sk next st, dc into next sp* 3 times, ch 1, dc in last st, turn. 6 sts

Row 10: Ch 1, dc into 1st st, ch 1, dc into sp, *ch 1, sk next st, dc into next sp* 3 times, ch 1, sk next st, dc in last st changing to MC1, turn. 6 sts

Don't forget to carry the yarn you're not using up along the edges at the beginning/end of each row.

2-colour Linen Stitch (MC+CC1)

Row 11 (MC1, WS): Ch 1, dc into 1st st, dc into sp, *ch 1, sk next st, dc into next sp* to last sp, ch 1, dc into last st changing to MC2, turn. 7 sts

Row 12 (MC2, RS): Ch 1, dc into 1st st, ch 1, dc into sp, *ch 1, sk next st, dc into next sp* to last sp, ch 1, sk next st, dc in last st changing to CC1, turn. 7 sts

Work these 2 rows of Linen Stitch increase repeat (see Special Stitches), changing colours at EOR as foll:

Row 13 (CC1): Work WS row, change to MC1. 8 sts

Row 14 (MC1): Work RS row, change to MC2. 8 sts

Row 15 (MC2): Work WS row, change to CC1. 9 sts

Row 16 (CC1): Work RS row, change to MC1. 9 sts

Row 17 (MC1): Work WS row, change to MC2. 10 sts

Row 18 (MC2): Work RS row, change to CC2. 10 sts

1-colour Linen Stitch (CC2)

Rows 19–28 (CC2): Work Linen Stitch increase repeat, change to MC2 at the EOR 28. 15 sts

2-colour Linen Stitch (MC+CC2)

Row 29 (MC2): Work WS row, change to MC1. 16 sts

Row 30 (MC1): Work RS row, change to CC2. 16 sts

Row 31 (CC2): Work WS row, change to MC2. 17 sts

Row 32 (MC2): Work RS row, change to MC1. 17 sts

Row 33 (MC1): Work WS row, change to CC2. 18 sts

Row 34 (CC2): Work RS row, change to MC2. 18 sts

Row 35 (MC2): Work WS row. 19 sts

Row 36 (MC2): Work RS row. 19 sts

Horizontal Rib stitch (MC)

Row 37 (MC2, WS): Work Row 1 of Horizontal Rib stitch repeat as foll: Ch 1, dc into 1st st, htr into each sp to EOR, htr into last st, changing to MC1. 20 sts

Row 38 (MC1, RS): Work Row 2 of Horizontal Rib stitch repeat as foll: Ch 1, (dc, ch 1, dc blo) into 1st st, ch 1 *dc blo, ch 1* into each htr, rep bet * to last 2 sts, work EOR dec over last 2 sts. 20 sts

Row 39 (MC1, WS): Rep Row 37, changing to MC2. 21 sts

Rows 40–44: Continue in Horizontal Rib stitch, changing between MC1 and MC2 at the end of every WS row. 23 sts

3-colour Linen Stitch (MC+CC1+CC2)

Row 45 (MC2, WS): Work WS row, change to MC1. 24 sts

Row 46 (MC1, RS): Work RS row, change to CC1. 24 sts

Row 47 (CC1): Work WS row, change to MC2. 25 sts

Row 48 (MC2): Work RS row, change to CC2. 25 sts

Row 49 (CC2): Work WS row, change to CC1. 26 sts

Row 50 (CC1): Work RS row, change to MC1. 26 sts

Row 51 (MC1): Work WS row, change to CC2. 27 sts

Row 52 (CC2): Work RS row, change to MC2. 27 sts

Row 53 (MC2): Work WS row, change to MC1. 28 sts

Row 54 (MC1): Work RS row, change to CC1. 28 sts

2nd colour band repeat

1-colour Linen Stitch (CC1)

Rows 55–64 (CC1): Work Linen Stitch repeat 5 times, change to MC1. 33 sts

2-colour Linen Stitch (MC+CC1)

Rows 65–72: Work Linen Stitch repeat changing colours as per Rows (11–18), change to CC2. 37 sts

1-colour Linen Stitch (CC2)

Rows 73–82 (CC2): Work Linen Stitch increase repeat, change to MC2 at the end of 82nd row. 42 sts

2-colour Linen Stitch (MC+CC2)

Rows 83–90: Work Linen Stitch repeat changing colours as per Rows (29–36). 46 sts

Horizontal Rib stitch (MC)

Rows 91–98: Rep Rows (37–44). 50 sts

3-colour Linen Stitch (MC+CC1+CC2)

Rows 99–108: Work Linen Stitch repeat changing colours as per Rows (45–54), change to CC1. 55 sts

3rd colour band repeat

1-colour Linen Stitch (CC1)

Rows 109–118 (CC1): Work Linen Stitch repeat 5 times, change to MC1. 60 sts

2-colour Linen Stitch (MC+CC1)

Rows 119–126: Work Linen Stitch repeat changing colours as per Rows (11–18), change to CC2. 64 sts

1-colour Linen Stitch (CC2)

Rows 127–136 (CC2): Work Linen Stitch increase repeat, change to MC2 at the end of 136th row. 69 sts

2-colour Linen Stitch (MC+CC2)

Rows 137–144: Work Linen Stitch repeat changing colours as per Rows (29–36). 73 sts

Horizontal Rib stitch (MC)

Rows 145–152: Rep Rows (37–44). 77 sts

3-colour Linen Stitch (MC+CC1+CC2)

Rows 153–154: Work Linen Stitch repeat changing colours as per Rows (45–46), change to CC1. 78 sts

Edging

Using markers, divide edges B and C (see Schematic) of the triangle into 8 equal sections to help distribute the edging stitches. This is easily done by lining up the corners and folding the edge in half, then marking the center, folding the 2 resulting sections in half and marking again, repeating until there are 8 equal sections on each side.

Round 1 (CC1, WS): Work a WS row of Linen Stitch to last st, (dc, ch 1, dc) into the last st, continue working into the side of the stitches of edge C, evenly distributing 16 rep of *ch 1, dc* into each of the 8 sections until next corner, (dc, ch 1, dc) into the corner.

Continue working into edge B, *ch 1, dc* 12 times into each of 8 sections; finish the round by working 1 dc into the same st as the 1st stitch of the round (at the corner), ch 1, ss to join, fasten off CC1 and CC2, remove all markers, turn.

Starting at the corner of sides A and B, where MC is still connected, pull up a loop.

Round 2 (MC, RS): *Ch 1, (dc, ch1, dc) into the corner sp, (ch 1, dc) into each space until next corner*, rep bet * twice more to EOR, dc into same st as the 1st stitch of the round, ch 1, ss to join.

Finishing

Weave all ends in. Lightly steam block to even out the edges.

