

OLYMPUS®

∞Zoom2000

∞Zoom2000 QUARTZ DATE

∞Zoom2000 DLX

■ INSTRUCTIONS

- Before using your camera, read this manual carefully to ensure correct use.
- We recommend that you take test shots to get accustomed to your camera before taking important photographs.

ADVANCED
TECHNIQUES

CAMERA
MAINTENANCE

Thank you for purchasing an Olympus camera.

MAIN FEATURES

- Built-in 38mm~70mm (approx. 2X) zoom lens
- Remote control (optional)
- Quartz date or time imprinting
(QUARTZDATE/DLX models only)

Symbols used in this manual:

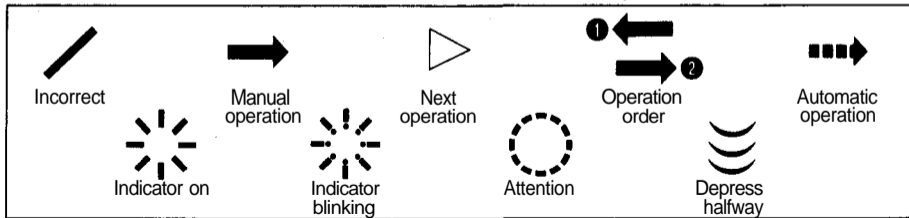

PREPARATIONS

Names and functions of parts	4	Loading the batteries	12
Viewfinder display/LCD panel	6	Checking the batteries	13
Using the strap and soft case	7	Points to remember	14
Outline of operations	8		

BASIC OPERATIONS

Loading the film	16
Taking pictures	18
Using the focus lock	22
Unloading the film	24

ADVANCED TECHNIQUES

Flash photography	25
Self timer	28
Remote control RC-100 (optional)	29
Printing the date and time (for QUARTZDATE/DLX models only)	30
Correcting the data (for QUARTZDATE/DLX models only)	31

CAMERA MAINTENANCE

Questions and answers	32
Care and storage	33
Battery handling	34
Troubleshooting	35
Specifications	40

NAMES AND FUNCTIONS OF PARTS

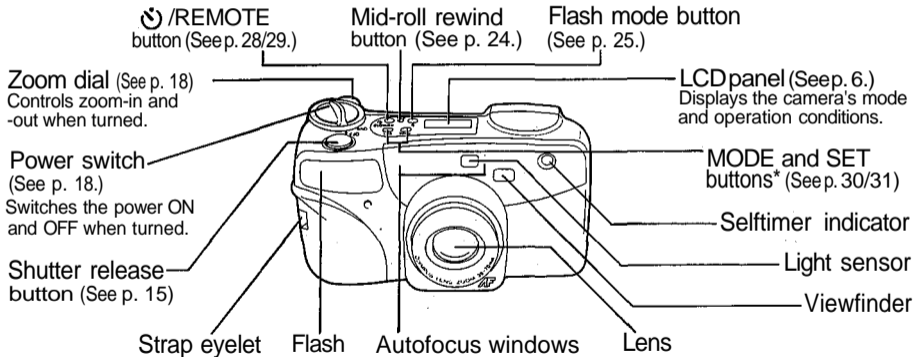

* QUARTZDATE/DLX models only

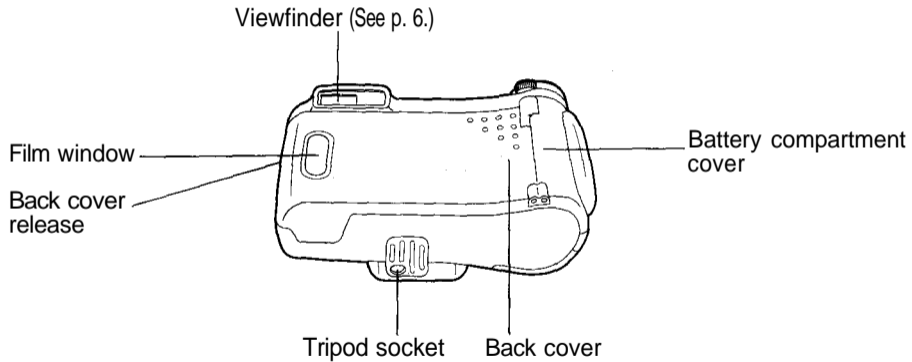

VIEWFINDER DISPLAY/LCD PANEL

VIEWFINDER DISPLAY

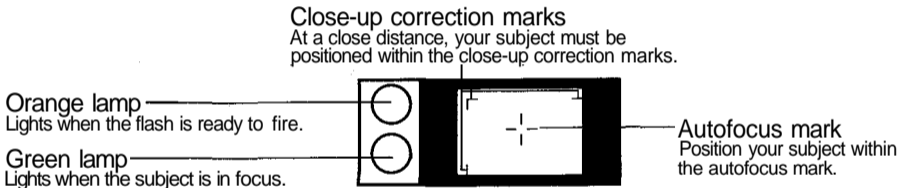

LCD PANEL

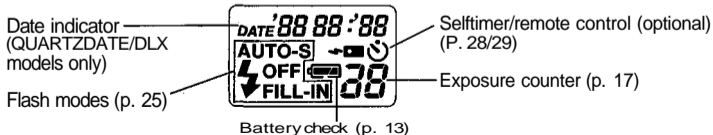

USING THE STRAP AND SOFT CASE

Attaching the Strap

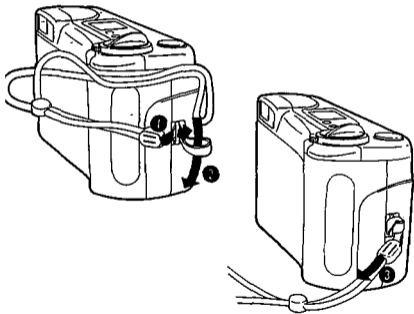

Using the Soft Case (optional)

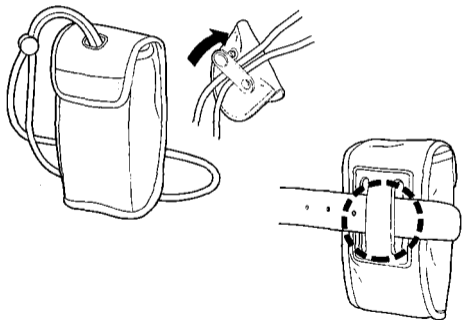

OUTLINE OF OPERATIONS

Basic Shooting Procedures

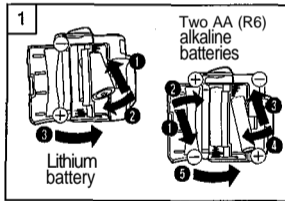

Load the batteries (p. 12).

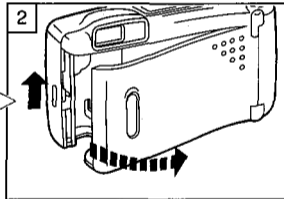

2

Open the back cover (p. 16).

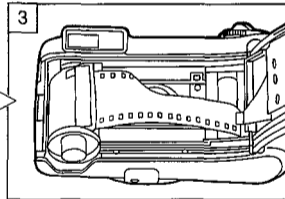

3

Load the film (p. 16).

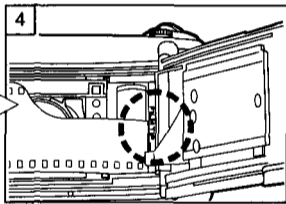

4
Align the film leader with the mark, and close the back cover (p. 17).

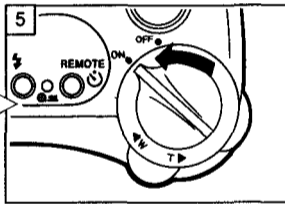

5
Set the ON/OFF switch to ON (p. 18).

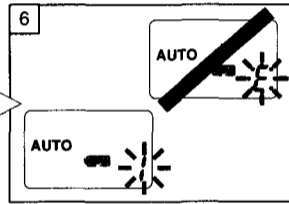

6
Make sure the exposure counter on the LCD panel reads / (p. 17).



Turn the zoom dial for telephoto or wide-angle photography (p. 18).



Place the autofocus mark on the subject you want to photograph (p. 19).

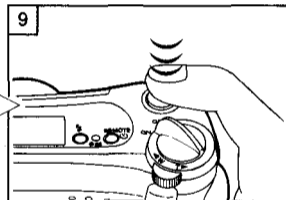

Depress the shutter release button halfway to make sure the green lamp lights (p. 20).

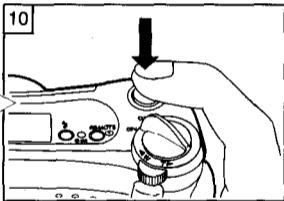

10
Depress the shutter release button fully to take a picture (p. 20).

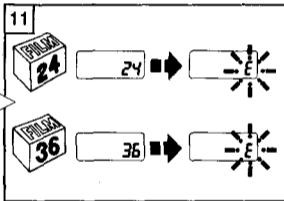

11
When the film reaches the end of the roll, it will automatically rewind (p. 24).

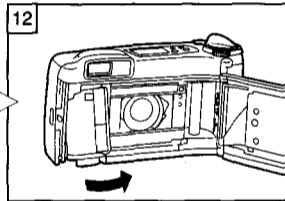

12
Open the back cover to remove the rewind film (p. 24).

LOADING THE BATTERIES

1. Remove the battery cover,

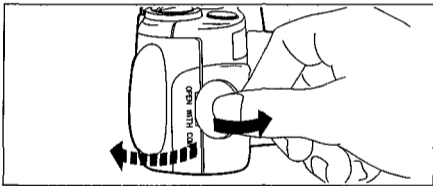

- Use one 3V lithium battery (CR123A or DL123A) or two AA (R6) alkaline batteries.
- Before loading the batteries, set the ON/OFF switch to OFF.
- The lens protector may sometimes open and close when the batteries have been loaded.

2. Insert the batteries, and replace the battery cover.

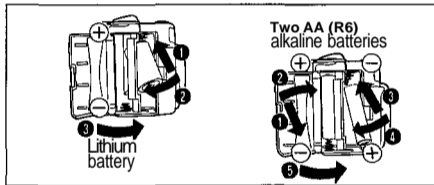





- Be sure the batteries are aligned correctly as shown.
- Insert the bottom of the battery first.

Read "Battery Handling" on page 34.

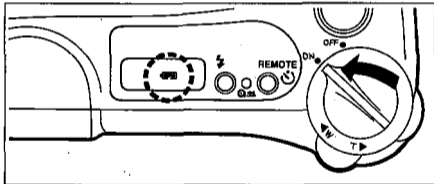
CHECKING THE BATTERIES

1. Set the ON/OFF switch to ON.



	Batteries are OK. The mark disappears after 12 sec.
 Blinks	Batteries are low. Have spares handy.
 Lights	Batteries should be replaced immediately.

POINTS TO REMEMBER

Hold the Camera Correctly.

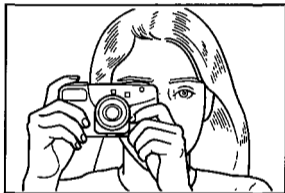

Correct.

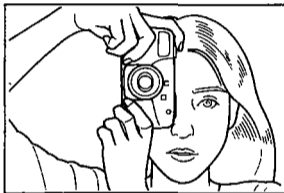

Correct.

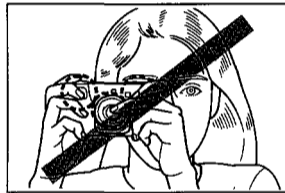

Incorrect.

- Hold the camera firmly with both hands.
- In the vertical position, hold the camera with its flash positioned at the top.

Caution:
Keep your fingers away from the lens, flash, autofocus windows and light sensor.

Proper Shutter Release. Practice before loading the film.

1. Depress the shutter release button halfway

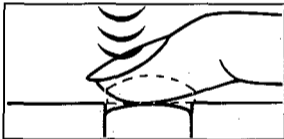

To lock the focus.

Make sure

The green lamp lights in the viewfinder.

2. Depress the shutter release button fully

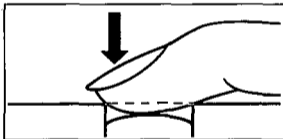

To release the shutter and take the picture.

Cautions:

- Press the shutter release button gently
- Avoid shaking the camera when pressing the shutter release button to prevent blurry pictures.

LOADING THE FILM

1. Slide the back cover release upward to open the back cover.

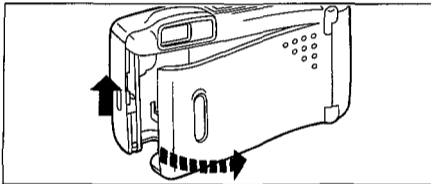

Note.
Be careful not to touch the camera's interior surfaces, such as the inside of the lens. When dust is stuck to the lens, use a blower brush, etc., to clean it.

2. Insert the film cartridge, making sure the film is lying flat.

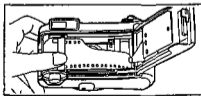
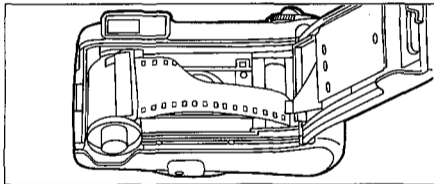

Correct

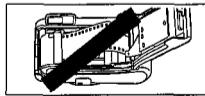

Incorrect

3. Align the film leader with the red mark, and close the back cover.

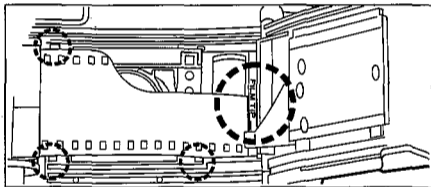

The film automatically advances to the first frame,

Make sure

The film does not overlap any of the positioning guides shown above.

4. Set the ON/OFF switch to ON.

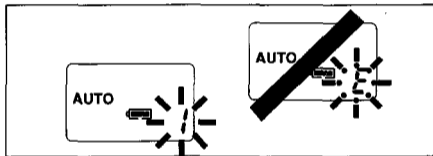

The exposure counter on the LCD panel reads 1

Note:

If **E** blinks in the exposure counter, as shown above, reload the film.

TAKING PICTURES

1. Rotate the power switch to turn the power ON.

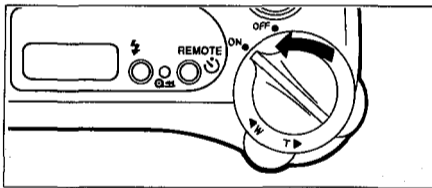

Make sure

The lens protector opens, the lens extends slightly, and the LCD panel activates.

2. Aim the camera at your subject. Use the zoom dial for telephoto or wide-angle photography.

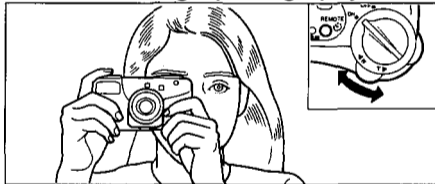

Telephoto: Turn the zoom dial to T.



Maximum telephoto focal length: 70 mm

Wide-angle: Turn the zoom dial to W.



Maximum wide-angle focal length: 38 mm

3. Position the autofocus mark  on your subject.



Autofocus mark

4. Depress the shutter release button halfway.

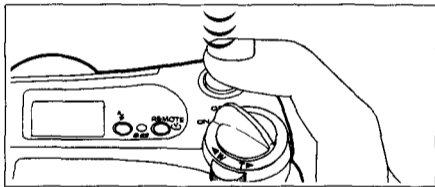

Make sure

The green lamp lights.

5. Depress the shutter release button fully.

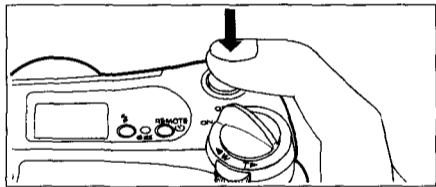

The film automatically advances to the next frame.

Working Distance

The focus range of the camera is 0.6m (2 ft) to ∞ (infinity).

- When the subject is closer than 0.6 m (2 ft), the shutter will not release. (The green lamp blinks.)
- When the subject is extremely close to the camera, the subject will be out of focus although the shutter releases.

Close-Up Correction

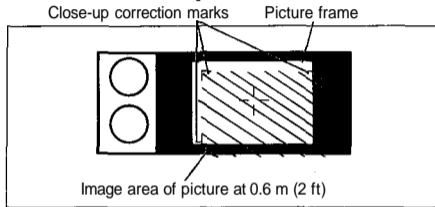

The viewfinder's picture frame shows the area that can be shot for subjects at ∞ . However, the picture area will move lower in the viewfinder as you get closer to the subject. At 0.6 m (2 ft), the shaded area is the actual available image area. In this case, the subject should be positioned below the close-up correction marks.

USING THE FOCUS LOCK

TO AVOID TAKING OUT-OF-FOCUS PICTURES

When the main subject is not in the center of the frame, use the focus lock.

Autofocus mark



The autofocus mark —|— must be positioned on the subject in order to focus on it. In the above case, the camera will focus on the tree in the background and the subjects will be out of focus.

1. Position the autofocus mark —|— on your subject and press the shutter release button halfway.



Make sure

The green lamp lights.



2. Reposition your subjects in the picture frame while keeping the shutter release button depressed halfway.

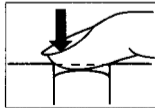

3. Depress the shutter release button fully to take picture.

Difficult Autofocus Subjects

- Glossy and reflective surfaces
- Black objects
- Subjects behind glass or wire mesh
- Flames and smoke
- Excessively bright light within the picture area

In the above situations, use the focus lock by focusing on a different subject at a similar distance. Then reposition the correct subject in the picture frame.

UNLOADING THE FILM

The camera automatically rewinds the film when you reach the end of a roll.

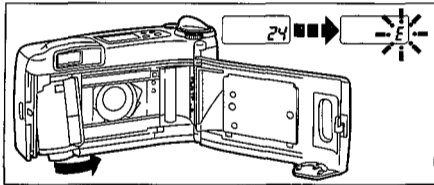

After the motor stops and ε starts blinking on the LCD panel, open the back cover and remove the film.

Note: The final number of exposures may sometimes exceed the number of exposures specified on the film.

Rewinding the film before the end of the roll

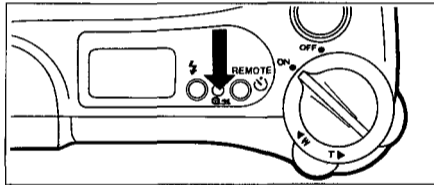

Press the mid-roll rewind button with the tip of a ballpoint pen, or the like. Do not use an instrument with a sharp tip.

FLASH PHOTOGRAPHY

This camera has four flash modes. Select the flash mode according to your shooting conditions and needs.

How to select the flash mode:

When the flash mode button is pressed, the flash mode changes in the order shown on the right. The selected flash mode is displayed on the LCD panel.

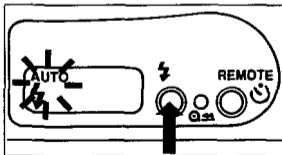

Mode	Function
AUTO	Automatically fires in low-light conditions. (p. 26)
AUTO-S	Significantly reduces the phenomenon of "red-eye" (when a subject's eyes appear red). (p. 26)
OFF	The flash does not fire. (p. 27)
FILL-IN	Fires regardless of available light. (p. 27)

Note: AUTO-S will not be canceled when the power is turned OFF. All other modes will return to the AUTO mode.

FLASH WORKING RANGE

ISO	W (Wide-Angle)	T (Telephoto)
100	0.6 ~ 3.8m (2 ~ 12.5 ft)	0.6 ~ 2.2 m (2 ~ 7.2 ft)
200	0.6 ~ 5.4m (2 ~ 17.7 ft)	0.6 ~ 3.1 m (2 ~ 10.2 ft)
400	0.6 ~ 7.6 m (2 ~ 24.9 ft)	0.6 ~ 4.4m (2 ~ 14.4 ft)

AUTO (Auto Flash)

In the Auto Flash mode, the flash will fire automatically in low-light conditions.

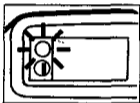

Make sure

The orange lamp in the upper left of the viewfinder lights when the shutter release button is depressed halfway.

Note: If the orange lamp blinks when the shutter release button is depressed halfway, the shutter won't release because the flash is being recharged. Remove your finger from the button and wait for several seconds before shooting.

AUTO-S (Red-Eye Reducing Flash)

Significantly reduces the phenomenon of "red-eye" (when a subject's eyes appear red in the final photograph).

In the Auto-S Flash mode, the camera will emit a series of low-power pre-flashes before the regular flash. This makes the subjects' pupils contract, significantly reducing red-eye. Except for the pre-flashes, this mode is the same as the Auto Flash mode.

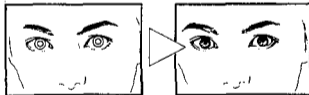

IMPORTANT: Be sure to hold the camera still until the shutter releases.

Note: Red-eye reduction may not be effective with some individuals or if the subject wasn't watching the pre-flashes.

OFF (Flash Override)

When you don't want the flash to fire, even in the dark.

In the Flash-Off mode, the flash does not fire even in low-light conditions. Use this mode in situations where flash photography is not desired or is prohibited.

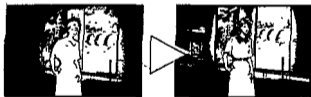

Note: Since a slow shutter speed (down to 1 second) is automatically selected in low-light situations, the use of a tripod is recommended to prevent blurred pictures caused by shaking the camera.

FILL-IN (Forced Activation)

When you want to fire the flash every shot.

In the Fill-in Flash mode, the flash fires regardless of available light. This mode can be used to brighten up a subject's shaded face, for example.



SELFTIMER

To Put Yourself in the Picture

1. Press the /REMOTE button.  is displayed on the LCD panel.

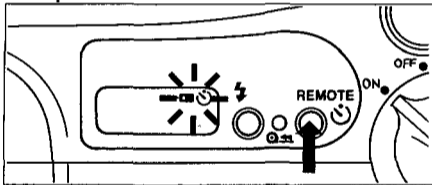

Notes:

- The focus and exposure will be locked when the shutter release button is depressed halfway.
- After the shutter is released, the Selftimer mode will be disengaged.
- To cancel the selftimer after it has been activated, press the /REMOTE button again.

2. Aim at your subject, and press the shutter release button.

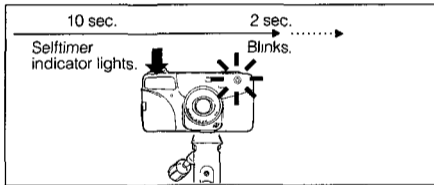

The shutter will be released 12 seconds later.

REMOTE CONTROL RC-100 (optional)

1. Press the  /REMOTE button.
 is displayed on the LCD panel.

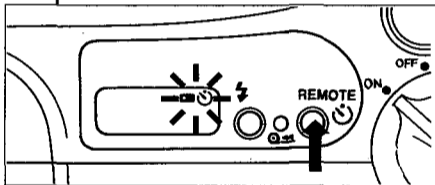

After shooting, press the  /REMOTE button again to cancel the selftimer/remote control mode.

CAUTIONS: ● KEEP THE REMOTE CONTROL OUT OF THE REACH OF CHILDREN. IF A CHILD SWALLOWS THE REMOTE CONTROL, CONTACT A DOCTOR IMMEDIATELY. ● NEVER TRY TO DISASSEMBLE THE REMOTE CONTROL. NEVER EXPOSE THE REMOTE CONTROL TO EXCESSIVE HEAT OR OPEN FLAME.

2. Aim the remote control at the camera, and press the button. The shutter will be released after 3 seconds.

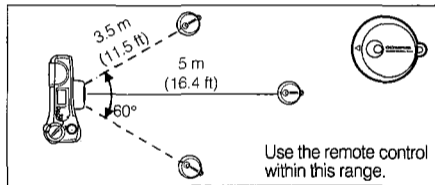

Notes: ● The camera will focus on the subject directly in front of it. ● In backlit situations, remote control shooting may sometimes be impossible.

PRINTING THE DATE AND TIME

(for QUARTZDATE/DLX models)

Choose the desired mode with the MODE button.

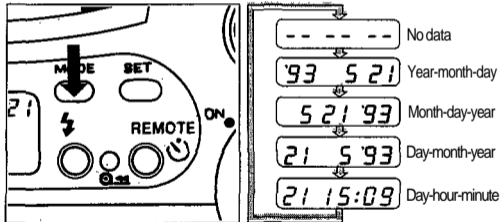

The mode will switch in the described order by pressing the MODE button.

The quartz date shares the power source with the main unit. Make sure to correct the data after the batteries are replaced.

The data is imprinted in the lower right of the picture. If there is something whitish or tinged with orange where the data is imprinted, the data may be difficult to read.

On the frame(s) after the specified final exposure of the film, the data may not be imprinted or may be superimposed.

CORRECTING THE DATA

(for QUART7DATE/DLX models)

1. Press the MODE button for two seconds or longer.

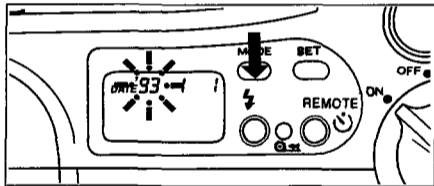

The year indication will start blinking

2. Press the mode button ① again to choose the data to be corrected until it starts blinking. And press the SET button ② to correct the data.

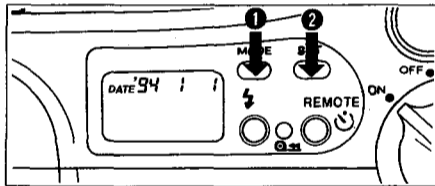

If you press the button once, the number on display will advance by 1. And if you keep it pressed, the numbers will run through in rapid succession.

Note: As you press the mode button, the blinking indication changes in the order of year, month, day, hour, and minute. The data correction will be finished when the mode button is pressed again.

QUESTIONS AND ANSWERS

Q: How long will the batteries last?

A: If you use 24-exposure rolls of film and use the flash on half of all your pictures, one new 3V lithium battery or two new AA (R6) alkaline batteries will last for approximately 12 rolls or 8 rolls respectively. If you do not use the flash and zoom very often, the batteries will last much longer.

Q: How should I clean the lens?

A: Wipe the lens gently with a soft, clean cloth. Do not use lens cleaning fluid.

Q: Can I use film that is not DX-coded?

A: Yes, but only ISO 100 film.

Q: When does the camera measure and set the exposure?

A: When the shutter release button is depressed halfway, the camera measures both the exposure and focus and locks them as long as the shutter release button remains halfway depressed.

Q: Can the battery in the optional remote control RC-100 be replaced with a new one?

A: No, it cannot be replaced but lasts about 5 years.

Q: It sounds like the film is advanced twice after the shutter releases. Is this a malfunction?

A: No, it isn't. The camera sounds that way because the motor is used to prepare the camera for the next shot as well as to advance the film.

CARE AND STORAGE

CAUTIONS

- DO NOT EXPOSE THE CAMERA TO EXTREME HEAT (OVER 40°C/104°F) OR TO EXTREME COLD (BELOW -10°C/14°F).
 - AVOID SUDDEN TEMPERATURE CHANGES AND HUMIDITY.
 - DO NOT EXPOSE THE CAMERA TO STRONG MAGNETIC FIELDS.
 - DO NOT APPLY EXCESSIVE FORCE TO THE CAMERA OR ITS CONTROLS.
 - DO NOT TOUCH THE CONTACT POINTS INSIDE THE CAMERA.
 - DO NOT USE ORGANIC SOLVENTS, THINNERS, OR BENZINE TO CLEAN THE CAMERA.
- AVOID STRONG IMPACT CAUSED BY BUMPING OR DROPPING THE CAMERA.
 - KEEP THE CAMERA DRY.
 - DO NOT EXPOSE THE CAMERA TO EXCESSIVE DUST AND SAND.

WARNING

- NEVER ATTEMPT TO DISASSEMBLE THE CAMERA, IT CONTAINS A HIGH-VOLTAGE CIRCUIT.

In case of malfunction, consult your nearest Olympus dealer or Olympus service center.

BATTERY HANDLING

NOTES

- Even when batteries are brand-new, their service life may be shorter than specified if an extended period of time has passed since they were produced.
- Do not mix different types of batteries or new and old batteries.
- When the camera is not to be used for an extended period of time (more than a year) remove the alkaline batteries from the camera to avoid damage from leakage.
- Keep spare batteries on hand when going on a long trip or to a cold area.

- Sweat and oil can prevent a battery's terminals from making electrical contact. To avoid this, wipe both terminals before loading batteries.

WARNINGS

- NEVER TRY TO DISASSEMBLE, RECHARGE, OR SHORT CIRCUIT BATTERIES. NEVER EXPOSE BATTERIES TO EXCESSIVE HEAT.
- KEEP THE BATTERIES OUT OF THE REACH OF CHILDREN. IF A CHILD SWALLOWS A BATTERY, CONTACT A DOCTOR IMMEDIATELY.
- USE ONE 3V LITHIUM BATTERY (CR123A OR DL123A) OR TWO AA (R6) ALKALINE BATTERIES. NEVER TRY TO DISASSEMBLE OR MODIFY ANY BATTERY OR BATTERY PACK FOR USE IN THIS CAMERA.

TROUBLESHOOTING

OPERATING PROBLEMS

Symptom	Cause	Remedy	See
The camera does not work.	<ul style="list-style-type: none">① The power is OFF② The alignment of the battery terminals is not correct.③ The batteries are exhausted.④ The batteries are temporarily unable to function.⑤ The loaded film has been rewound.⑥ The film is incorrectly loaded.	<ul style="list-style-type: none">① Set the ON/OFF switch to ON.② Reload the batteries correctly.③ Replace the batteries with new ones.④ Keep the camera warm while using it. ⑤ Remove the film.⑥ Reload the film.	<ul style="list-style-type: none">p. 18p. 12 p. 13p. 33 p. 24p. 17
The LCD display turns off suddenly	<ul style="list-style-type: none">① The LCD display turns off after four and a half minutes if the camera is not used.	<ul style="list-style-type: none">① Turn the power off and then on again or press the shutter release button halfway to turn on the LCD panel. In addition, the power is turned OFF automatically after 4 hours. When the camera is not in use, keep the power OFF as much as possible.	

OPERATING PROBLEMS

Symptom	Cause	Remedy	See
The shutter doesn't release when the remote control's shutter release button is pressed.	① The remote control hasn't been used in the 15 minutes since the Selftimer/Remote Control mode was entered, causing the LCD panel to turn off.	① Turn the zoom dial. The LCD will light. Then press the  /REMOTE button again.	
The green lamp blinks, and the shutter will not release.	① The camera is too close to the subject.	① Move the camera farther than 0.6 m (2 ft) from the subject.	p. 21
The orange lamp blinks, and the shutter will not release.	① The flash has not been recharged yet.	① Remove your finger from the shutter release button and wait for several seconds until the flash is recharged before shooting.	p. 26
The flash does not fire, even in the dark.	① The flash mode is set to OFF. ② High-speed film is used.	① Set it to a mode other than OFF ② Set the flash mode to FILL-IN	p. 25

PROBLEMS WITH THE PRINTED PICTURES

Symptom	Cause	Remedy	See
The picture is out of focus.	<ul style="list-style-type: none">① The camera moved when the shutter release button was pressed.② The subject was not within the viewfinder's autofocus mark.③ The lens and autofocus windows were dirty.④ The autofocus window was blocked, such as by a finger.	<ul style="list-style-type: none">① Hold the camera correctly and press the shutter release button gently.② Position the subject in the center of the autofocus mark, or use the focus lock.③ Clean the lens and autofocus windows.④ Hold the camera correctly, keeping your fingers clear of the autofocus windows.	<p>p. 14</p> <p>p. 22</p> <p>p. 14</p>

PROBLEMS WITH THE PRINTED PICTURES

Symptom	Cause	Remedy	See
The picture is out of focus.	<ul style="list-style-type: none"> ⑤ The subject was closer than the minimum working distance to the lens (0.6 m/2 ft). ⑥ While using the self-timer, the shutter release button was pressed while standing right in front of the camera. ⑦ When using the self-timer to photograph yourself, the autofocus has been set on the background. 	<ul style="list-style-type: none"> ⑤ Shoot from more than 0.6 m (2 ft) away from the subject. ⑥ Do not stand in front of the camera. Press the shutter release button while looking through the viewfinder. ⑦ Use the focus lock to set focus on an object at the same distance from the camera as you will be 	<p>P. 21</p> <p>p. 28</p> <p>p.22/28</p>
The picture is too dark.	<ul style="list-style-type: none"> ① The flash was blocked, such as by a finger. ② The subject was out of the working range of the flash. ③ The subject was backlit 	<ul style="list-style-type: none"> ① Hold the camera correctly, keeping your fingers clear of the flash. ② Shoot within the flash working range. ③ Set the flash mode to FILL-IN. 	<p>p. 14</p> <p>p. 25</p> <p>p. 27</p>

Symptom	Cause	Remedy	See
The date has not been printed (or looks faded)*	<ul style="list-style-type: none"> ① The date mode was set to no data (---). ② There is a bright color like white, orange, or yellow in the area of the picture where the date is printed. ③ The picture was taken with black-and-white film. 	<ul style="list-style-type: none"> ① Change the date mode to another setting. ② Avoid bright colors in the lower left corner of your photo compositions. ③ Do not use black-and-white film. 	p. 30

*QUARTZDATE/DLX models only

SPECIFICATIONS

Type: Full automatic 35mm autofocus lens-shutter camera with built-in 38 ~ 70mm zoom lens.

Film format: 35mm standard DX-coded film (24 X 36 mm).

Lens: Olympus lens 38 ~ 70mm F4.5 ~ 7.8, 5 elements in 4 groups.

Shutter: Programmed electronic shutter.

Viewfinder: Real image type zoom viewfinder (with autofocus mark, close-up correction marks, autofocus indicator and flash indicator).

Focusing: Active type autofocus system. Focus lock possible. Focusing range: 0.6 m (2 ft) ~ ∞ (infinity).

Exposure control: Programmed automatic exposure control. Center-weighted average light metering. Auto exposure range: Wide-angle — EV4.4 (F4.5, 1 sec.) to EV16(F11, 1/500 sec.), Telephoto — EV5.9 (F7.8, 1 sec.) to EV17.5 (F19, 1/500 sec.).

Exposure counter: Progressive type with automatic reset, displayed on LCD panel.

Self-timer: Electronic self-timer 12-sec. delay.

Remote control (optional): Infrared remote control unit with 3-sec. delay.

Film speed range: Automatic setting with DX-coded film with ISO 50, 100, 200, 400, 800, 1600, 3200. For non-DX-coded film and film speeds lower than ISO50, film speed is set to ISO 100.

Film loading: Automatic loading. (Automatically advances to first frame when camera back is closed).

Film advance: Automatic film winding.

Film rewind: Automatic film rewind (automatic rewind activation at end of film, automatic rewind stop). Rewind possible at any point with rewind button.

Flash: Built-in flash. Recycling time: Approx. 5 sec. (at normal temperature with new batteries).
Flash working range: Wide-angle — 0.6 ~ 3.8 m (2 ~ 12.5 ft), Telephoto — 0.6 ~ 2.2 m (2 ~ 7.2 ft) with ISO 100 color negative film; Wide-angle — 0.6 ~ 7.6 m (2 ~ 24.9 ft), Telephoto — 0.6 ~ 4.4m (2 - 14.4 ft) with ISO 400 color negative film. Flash modes: AUTO (Automatic flash activation in low light). AUTO-S (Red-eye

reducing, in low light). OFF (No flash). FILL-IN (Forced activation).

Battery check: Displayed on LCD panel.

Power source: One 3V lithium battery (CR123A or DL123A) or two AA (R6) alkaline batteries.

Dimensions: 128(W) X 66(H) X 50(D) mm (5-1/16 X 2-5/8 X 1-15/16 in) (without protrusions).

Weight: 235 g (8.3 oz) (without batteries).

SPECIFICATIONS FOR DATE UNIT*

Imprinting direction: Data imprinted onto film from lens side.

Data coding: No data, year-month-day, month-day-year, day-month-year and day-hour-minute.

External indication of data: Data display on liquid crystal panel.

Film speed setting: Automatic film speed setting.

Automatic calendar system: Up to year 2013.

Power source: Ordinarily used with camera body.

*QUARTZDATE/DLX models only

SPECIFICATIONS AND DESIGN ARE SUBJECT TO CHANGE WITHOUT ANY NOTICE OR OBLIGATION ON THE PART OF THE MANUFACTURER.

OLYMPUS®

OLYMPUS OPTICAL CO., LTD.

San-Ei Building, 22-2, Nishi Shinjuku 1-chome, Shinjuku-ku, Tokyo, Japan. Tel. 03-3340-2211

OLYMPUS AMERICA INC.

Two Corporate Center Drive, Melville, NY 11747-3157, U.S.A. Tel. 516-844-5000

OLYMPUS OPTICAL CO. (EUROPA) GMBH.

(Premises/Goods delivery) Wendenstrasse 14-16, 20097 Hamburg, Germany. Tel. 040-237730

(Letters) Postfach 10 49 08, 20034 Hamburg, Germany.

OLYMPUS OPTICAL CO. (U.K.) LTD.

2-8 Honduras Street, London EC1Y 0TX, United Kingdom. Tel.