



Model: 116513-13
116513-29*
116513-32*

DESCRIPTION

- Three stage
- 36 volts
- 5.7"/145 mm diameter
- Double ball bearings
- Single speed
- Tangential bypass discharge
- Thermoset fan end bracket
- Aluminum commutator bracket

DESIGN APPLICATION

- Equipment operating in environments requiring separation of working air from motor ventilating air
- Designed to handle clean, dry, filtered air only

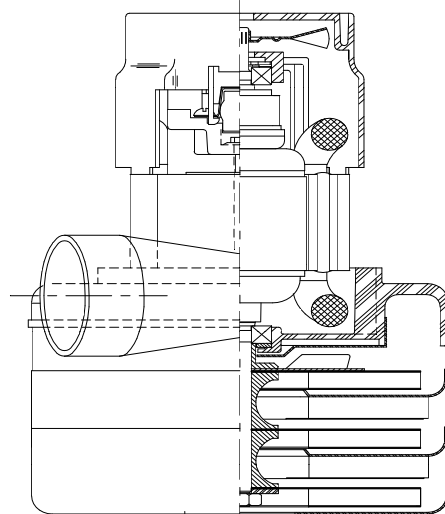

SPECIAL FEATURES

- Suitable for 36 volt DC operation
- UL Recognized, category PRGY2 (E47185)
- Provision for grounding
- Skeleton-frame design
- Epoxy painted fan case
- Patented air seal bearing construction, U.S. Patent #4,088,424
- The Lamb Electric vacuum motor line offers a wide range of performance levels to meet design needs

***Model 116513-29 features inlet tube 1.50" diameter x 1.0" long**

***Model 116513-32 features inlet tube 1.895" diameter x 1.0" long**

TYPICAL MOTOR PERFORMANCE.*

(At 36 volts DC, test data is corrected to standard conditions of 29.92 Hg, 68° F.)

ASTM DATA

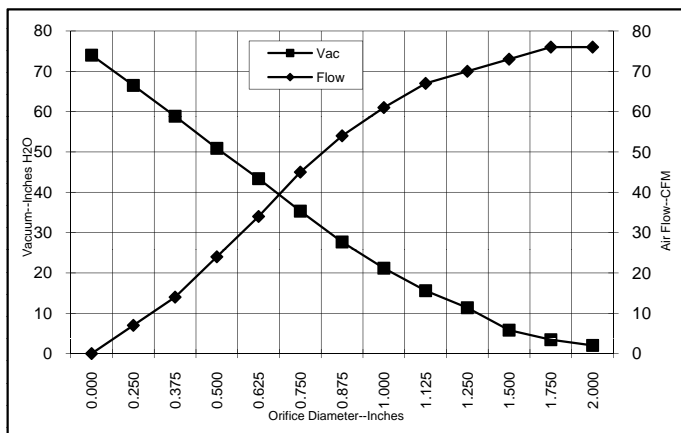

Orifice (Inches)	Amps	Watts (In)	RPM	Vac (In.H ₂ O)	Flow (CFM)	Air Watts
2.000	17.4	653	14125	2.0	76.0	18
1.750	17.4	656	14138	3.4	76.0	31
1.500	17.6	659	14088	5.8	73.0	49
1.250	17.8	666	14000	11.4	70.0	94
1.125	17.9	670	13925	15.6	67.0	122
1.000	17.9	672	13888	21.2	61.0	153
0.875	17.8	669	13975	27.7	54.0	175
0.750	17.4	654	14188	35.3	45.0	185
0.625	16.7	627	14563	43.4	34.0	175
0.500	15.7	592	15275	50.9	24.0	142
0.375	14.5	549	16025	58.9	14.0	100
0.250	13.5	511	17013	66.5	7.0	53
0.000	12.6	478	17950	74.0	0.0	0

METRIC DATA

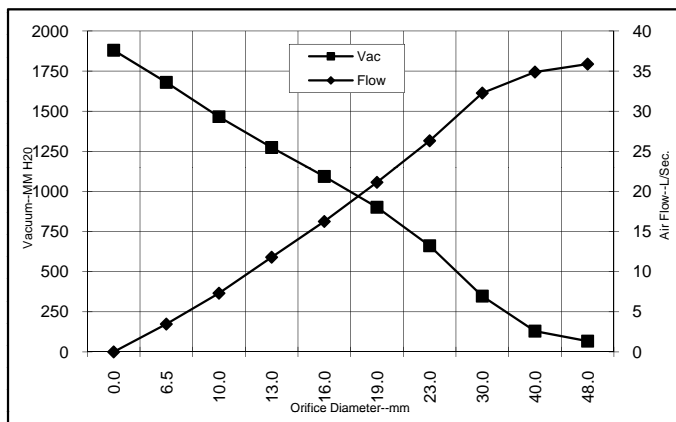

Orifice (mm)	Amps	Watts (In)	RPM	Vac (mm H ₂ O)	Flow (L/Sec)	Air Watts
48.0	17.4	654	14131	67	35.9	24
40.0	17.5	658	14103	130	34.9	44
30.0	17.8	668	13959	348	32.3	109
23.0	17.8	670	13953	662	26.3	170
19.0	17.4	653	14196	901	21.1	185
16.0	16.7	628	14548	1093	16.3	175
13.0	15.8	596	15204	1274	11.8	145
10.0	14.7	555	15913	1465	7.3	106
6.5	13.6	513	16964	1679	3.5	55
0.0	12.6	478	17950	1880	0.0	0

Note: Metric performance data is calculated from the ASTM data above.

* Data represents performance of a typical motor sampled from a large production quantity. Individual motor data may vary due to normal manufacturing variations.

Test Specs:	36 volts	Minimum Sealed Vacuum:	70.0"	ORIFICE:	7/8 "	Minimum Vacuum:	26.0"	Maximum Watts:	738
--------------------	-----------------	-------------------------------	--------------	-----------------	--------------	------------------------	--------------	-----------------------	------------

DIMENSIONS

NOTES:

- LEADS: 14GA. STRANDED, LEADS CAN BE ANY COLOR EXCEPT GREEN OR GREEN WITH YELLOW STRIPE.
- GROUNDING OR EARTHING PROVISIONS: USE HOLES AS INDICATED FOR GROUNDING OR EARTHING. REFER TO APPROPRIATE LISTING OR REGULATORY AGENCY FOR PROPER METHOD OF GROUNDING OR EARTHING.

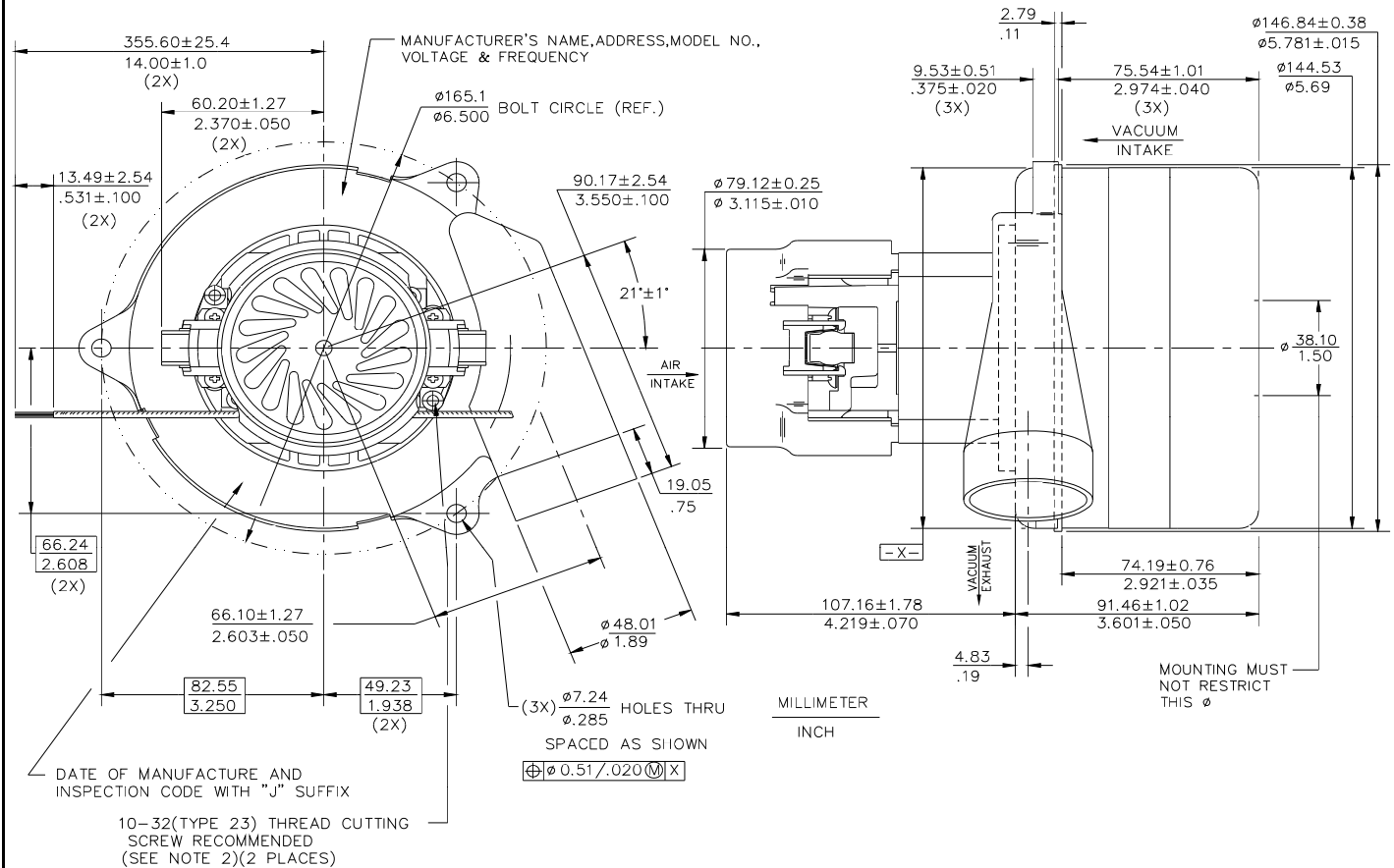

IMPORTANT NOTE: Pictorial and dimensional data are subject to change without notice. Contact factory for current revision levels.

WARNING - When using AMETEK Lamb Electric bypass motors in machines that come in contact with foam, liquid (including water), or other foreign substances, the machine must be designed and constructed to prevent those substances from reaching the fan system, motor housing, and electrical components. Lamb Electric vacuum motors other than hazardous duty models should not be applied in machines that come in contact with dry chemicals or other volatile materials. Failure to observe these precautions could cause flashing (depending on volatility) or electrical shock which could result in property damage and severe bodily injury, including death in extreme cases. All applications incorporating Lamb Electric motors should be submitted to appropriate organizations or agencies for testing specifically related to the safety of your equipment.

AMETEK/Lamb Electric Division
627 Lake Street
Kent, Ohio 44240
U.S.A.
Tel: (330) 673-3451
Fax: (330) 673-8994

Ametek GmbH
P. O. Box 1251
D-71667 Marbach
Germany
Phone: + 49-714-484-9512
Fax: + 49-714-484-9513

AMETEK/Singapore Private Limited
10 Ang Mo Kio Street 65
05-12 Techpoint
Singapore 2056
Tel: + 65-484-2388
Fax: + 65-481-6588

Issued: March, 1998