

Butterfly valve with Wafer types

- For open and closed cold and warm water systems
- For switching heat generators or cooling machines on and off

Type overview

Type	DN []	kvmax [m ³ /h]	kvs [m ³ /h]	PN []
D625N	25	50	24	6 / 10 / 16
D632N	32	55	25	6 / 10 / 16
D640N	40	65	27	6 / 10 / 16
D650N	50	100	30	6 / 10 / 16
D665N	65	170	50	6 / 10 / 16
D680N	80	260	75	6 / 10 / 16
D6100N	100	520	150	6 / 10 / 16
D6125N	125	880	260	6 / 10 / 16
D6150N	150	1400	400	6 / 10 / 16
D6350N	350	10300	3010	10 / 16
D6400N	400	14200	4140	16
D6450N	450	18800	5490	16
D6500N	500	24100	7060	16
D6600N	600	37300	10900	16

The types D6200N, D6250N and D6300N have been replaced by the types D6200W, D6250W and D6300W. For technical data please check the datasheet D6..W.

Technical data

Functional data	Media	Cold and warm water, water with glycol up to max. 50% vol.
	Medium temperature	-20...120° C
	Permissible pressure ps	1600 kPa
	Leakage rate	Leakage rate A, tight (EN 12266-1)
	Angle of rotation	90°
	Installation position	Upright to horizontal (in relation to the stem)
	Suitable connection flange	In accordance with ISO 7005-2 and EN 1092-2
		PN6/10/16, AS Table E (DN50...150)
		PN10/16, AS Table E (DN350)
		PN16, (DN400...600)
Maintenance	Maintenance-free	
Materials	Body	Ductile iron EN-GJS-400-15 (GGG 40), polyester-powder coating
	Closing element	1.4301 (Stainless steel 304)
	Stem	1.4021 (Stainless steel 420)
	Stem seal	O-ring EPDM
	Stem bearing	RPTFE
	Seat	EPDM

Safety notes

- The valve has been designed for use in stationary heating, ventilation and air-conditioning systems and must not be used outside the specified field of application, especially in aircraft or in any other airborne means of transport.

Safety notes

- Only authorised specialists may carry out installation. All applicable legal or institutional installation regulations must be complied during installation.
- The valve does not contain any parts that can be replaced or repaired by the user.
- The valve may not be disposed of as household refuse. All locally valid regulations and requirements must be observed.
- When determining the flow rate characteristic of controlled devices, the recognised directives must be observed.
- The damper must be opened and closed slowly in order to avoid hydraulic shocks in the pipe system.

Product features

- Mode of operation** The butterfly valve is opened or closed completely by an open-close rotary actuator. Continuous rotary actuators are connected by a commercially available controller and move the valve to any position desired. The valve disk made of stainless steel is pressed into the soft-sealing EPDM seat by a rotary movement and ensures leakage rate A (tight). The pressure losses are slight in the open position and the kv value is at a maximum.
- Manual override** Manual throttling or shut-off can be carried out with a lever or a worm gear (see «Accessories»).
- With lever (DN25...150): Adjustable in 10 ratchet steps with position indication (0 = 0° (angle); 9 = 90° (angle))
 - With worm gear (DN25...600): steplessly adjustable (self-locking) with position indication.

Accessories

	Description	Type
Electrical accessories	Stem heating flange ISO 5211, F05 (30W)	ZR24-F05
Mechanical accessories	Worm gear for D6.. butterfly valves, DN25...DN100	ZD6N-S100
	Manual control for D6.. butterfly valves, for DN25...DN100	ZD6N-H100
	Worm gear for butterfly valves DN125...150	ZD6N-S150
	Manual control for D6.. butterfly valves, for DN125...DN150	ZD6N-H150
	Worm gear for D6.. butterfly valves, DN350	ZD6N-S350
	Worm gear for D6.. butterfly valves, DN400	ZD6N-S400
	Worm gear for D6.. butterfly valves, DN450	ZD6N-S450
	Worm gear for D6.. butterfly valves, DN500	ZD6N-S500
	Worm gear for D6.. butterfly valves, DN600	ZD6N-S600

Installation notes

- Recommended installation positions** The butterfly valves may be mounted upright to horizontal. The butterfly valves may not be installed in a hanging position i.e. with the spindle pointing downwards.

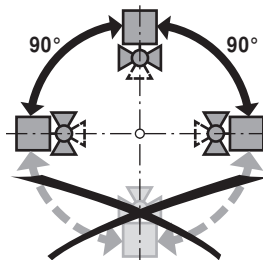

- Water quality requirements** The water quality requirements specified in VDI 2035 must be adhered to.
- Stem heating** In cold water applications and warm humid ambient air can cause condensation in the actuators. This can lead to corrosion in the gear box of the actuator and causes a breakdown of it. In such applications, the use of a stem heating is provided. The stem heating must be enabled only when the system is in operation, because it does not have temperature control.

Installation notes

Maintenance Butterfly valves and rotary actuators are maintenance-free. Before any service work on the final controlling device is carried out, it is essential to isolate the rotary actuator from the power supply (by unplugging the electrical cable if necessary). Any pumps in the part of the piping system concerned must also be switched off and the appropriate slide valves closed (allow all components to cool down first if necessary and always reduce the system pressure to ambient pressure level). The system must not be returned to service until the butterfly valve and the rotary actuator have been reassembled correctly in accordance with the instructions and the pipeline has been refilled by professionally trained personnel. To avoid a torque increase during off season shut down, exercise the butterfly valve (full open and close) at least once a month.

Flow setting The Belimo butterfly valves have an approximate equal percentage characteristic curve between 0 and 60 percent opening angle.

		10%	20%	30%	40%	50%	60%	70%	80%	90%	100%
DN 25	kv (m ³ /h)	0.1	2	6	10	15	24	36	46	48	50
DN 32	kv (m ³ /h)	0.1	2	6	11	15	25	38	49	51	55
DN 40	kv (m ³ /h)	0.1	2	6	11	16	27	41	59	62	65
DN 50	kv (m ³ /h)	0.1	2	6	11	18	30	45	67	90	100
DN 65	kv (m ³ /h)	0.1	4	9	17	30	50	76	110	160	170
DN 80	kv (m ³ /h)	0.2	6	13	26	50	75	120	170	240	260
DN 100	kv (m ³ /h)	0.2	12	26	50	90	150	230	350	480	520
DN 125	kv (m ³ /h)	0.4	20	40	90	160	260	400	590	810	880
DN 150	kv (m ³ /h)	1	30	70	140	250	400	620	910	1260	1400
DN 350	kv (m ³ /h)	5	240	520	1050	1860	3010	4640	6880	9470	10300
DN 400	kv (m ³ /h)	6	320	720	1450	2560	4140	6380	9460	13030	14200
DN 450	kv (m ³ /h)	9	430	950	1920	3400	5490	8460	12530	17250	18800
DN 500	kv (m ³ /h)	11	550	1220	2460	4370	7060	10870	16110	22190	24100
DN 600	kv (m ³ /h)	17	850	1880	3800	6740	10900	16800	24890	34280	37300



Table: Valve opening / flow

Dimensions / Weight

Dimensional drawings

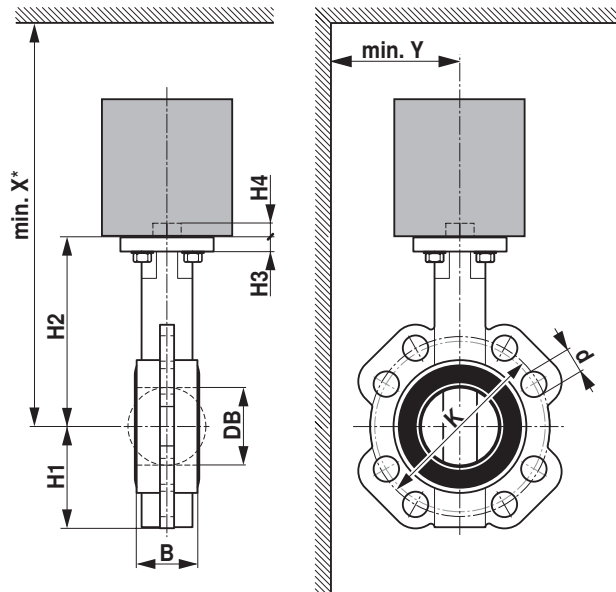

Type	DN []	B [mm]	DB [mm]	H1 [mm]	H2 [mm]	H3 [mm]	H4 [mm]	d (PN6) [mm]	K (PN6) [mm]	d (PN10) [mm]	K (PN10) [mm]
D625N	25	32	30	57	86	10	13	4 x 11	75	4 x 14	85
D632N	32	33	35	60	100	10	13	4 x 14	90	4 x 19	100
D640N	40	33	42	68	119	10	13	4 x 14	100	4 x 19	110
D650N	50	43	52	72	133	11	13	4 x 14	110	4 x 19	125
D665N	65	46	64	81	147	11	13	4 x 14	130	4 x 19	145
D680N	80	46	78	96	158	11	13	4 x 19	150	8 x 19	160
D6100N	100	52	103	106	170	11	13	4 x 19	170	8 x 19	180
D6125N	125	56	122	122	194	15	19	8 x 19	200	8 x 19	210
D6150N	150	56	155	140	202	15	19	8 x 19	225	8 x 23	240
D6350N	350	78	333	267	361	15	24			16 x 23	460
D6400N	400	102	391	308	400	20	48				
D6450N	450	114	442	337	422	22	48				
D6500N	500	127	493	359	480	22	48				
D6600N	600	154	594	454	562	25	48				

Type	d (PN16) [mm]	K (PN16) [mm]	d (Table E) [mm]	K (Table E) [mm]	X [mm]	Y [mm]	Weight [kg]
D625N	4 x 14	85	4 x 14	83	320	150	1.1
D632N	4 x 19	100	4 x 14	87	340	150	1.5
D640N	4 x 19	110	4 x 14	98	350	160	1.6
D650N	4 x 19	125	4 x 18	114	370	160	2.4
D665N	4 x 19	145	4 x 18	127	380	170	3.0
D680N	8 x 19	160	4 x 18	146	390	180	3.3
D6100N	8 x 19	180	8 x 18	178	410	190	4.0
D6125N	8 x 19	210	8 x 18	210	530	210	6.7
D6150N	8 x 23	240	8 x 22	235	540	220	7.4
D6350N	16 x 28	470	12 x 26	470	1200	340	34
D6400N	4 x 31	525			1300	1300	60
D6450N	4 x 31	585			1300	1400	73
D6500N	4 x 33	650			1700	1500	98
D6600N	16 x 37	770			1800	1800	190

* min.X depends on actuator selection

Further documentation

- Overview Valve-actuator combinations
- Data sheets for actuators
- Installation instructions for actuators and/or butterfly valves
- General notes for project planning