

EVO

OWNER'S MANUAL

THE BEST BRANDS FOR YOUR VINYL SYSTEMS CUTTER



Siser EasyWeed Heat Transfer Vinyl is an easy to use material that is ready to cut and allows you to weed out your letters and numbers with ease.



Paropy Heat Transfer Paper is widely known as the premier brand in quality heat transfer paper. Designed to transfer with no visible background



Neenah Paper has been an industry leader in the creation, development, and improvement of heat transfer products since their first patent was granted in 1980.



Specialty Materials heat transfer film produces durable polyurethane based materials for all your needs.



Apply custom designs to your fabric quick and easily with Chemica heat transfer vinyl. Chemica heat transfer vinyl will save you time without sacrificing quality.



Oracal is known around the world as the premiere adhesive vinyl for your production needs. Best of all, it is available in a wide selection of colors and sizes.

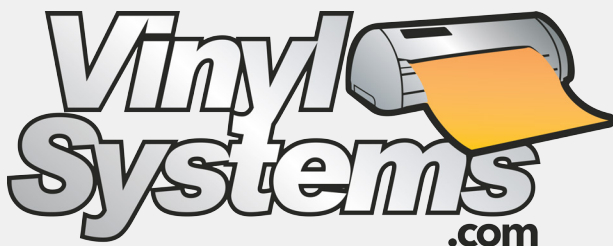

Available at: 800-664-8090

WEEKDAYS 7:00AM-5:00PM PST

WWW.VINYLSYSTEMS.COM

GETTING STARTED	1
WHAT COMES IN THE BOX	2
MEET YOUR NEW CUTTER	3
BASIC KNOWLEDGE	5
LET'S BUILD THE STAND	7
BLADE SET UP	8
LCD CONTROL INTERFACE	11
TROUBLESHOOTING	12
MAINTENANCE	13
SALES & SERVICE	14

GETTING STARTED

Thank You for purchasing a Vinyl Systems Evo! Before you get started, it is important you understand following.

1. Remove the vinyl cutter and all of it's accessories out of the box. Inspect all parts and make sure you have received all of them.
2. Install the stand and ensure it is mounted securely.
3. Plug in your vinyl cutter to your computer with the included A-B USB 2.0 cable.
4. Plug in your AC Power cord directly into the wall, surge protector, extension cord, or power strip.
5. Install the blade into the blade holder and make sure the latch on your carriage is closed and locked over the proper place.
6. Proceed reading the Sign Master Walkthrough Guide to set up your cutting software.
7. Familiarize yourself with the control interface to make sure you understand what each function does.



WHAT COMES IN THE BOX

Before proceeding, make sure you have the following

- A. Cutter/Plotter
- B. Power Cord (x1)
- C. Blade 45° (x1)
- D. Blade holder (x1)
- E. Pen holder (x1)
- F. Pen (x1)
- G. Serial cable (x1)
- H. USB cable (x1)
- I. Allen wrench (x1)
- J. Installation CD (x1)
- K. Digital Manual (x1)
- L. Support screw (x1) (optional)
- M. Dust cover (x1) (optional)

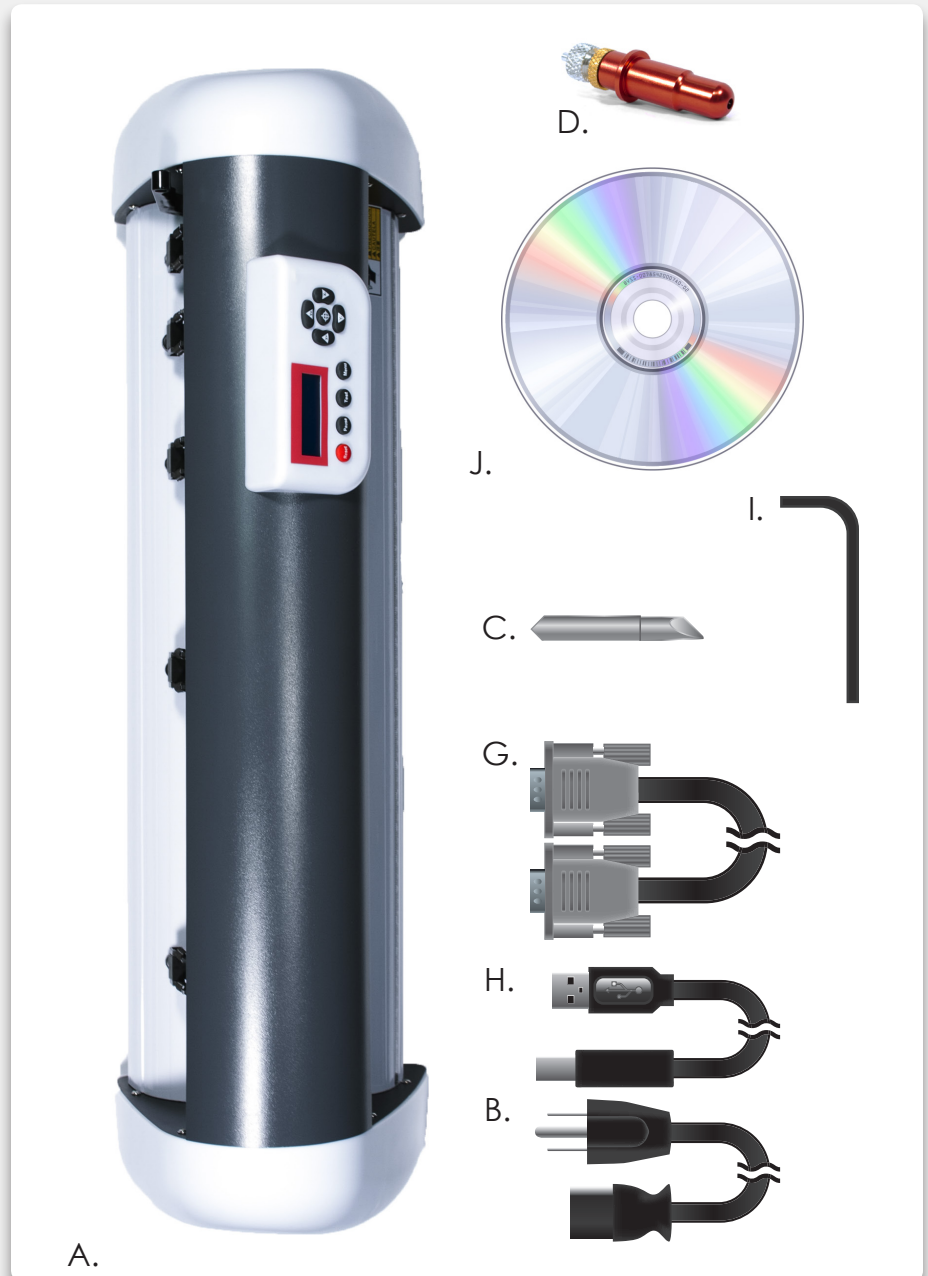

Call (800)664-8090 if any parts are missing

MEET YOUR NEW CUTTER

FRONT VIEW

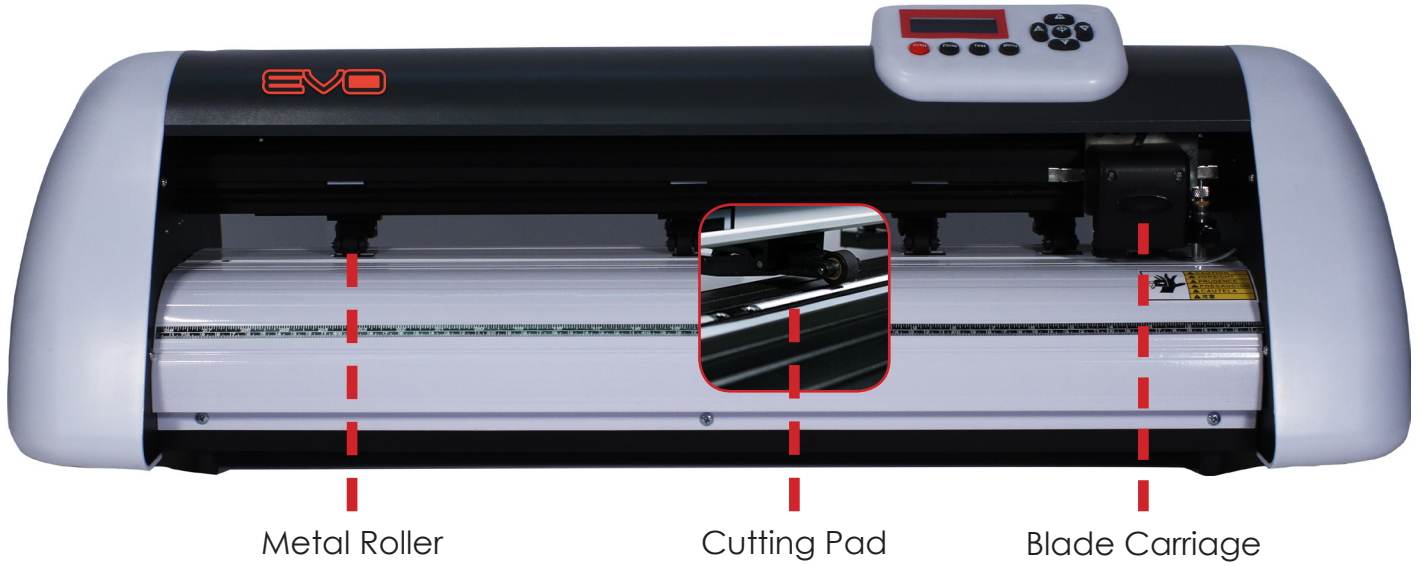

REAR VIEW

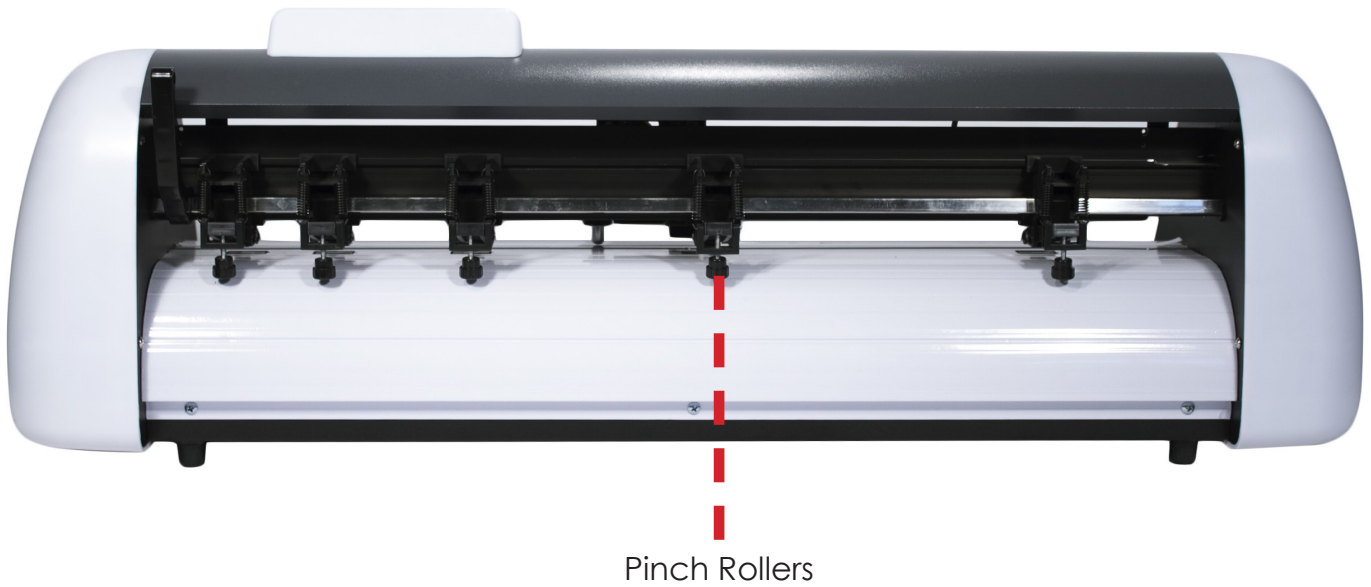

MEET YOUR NEW CUTTER

COMPUTER GAUGE

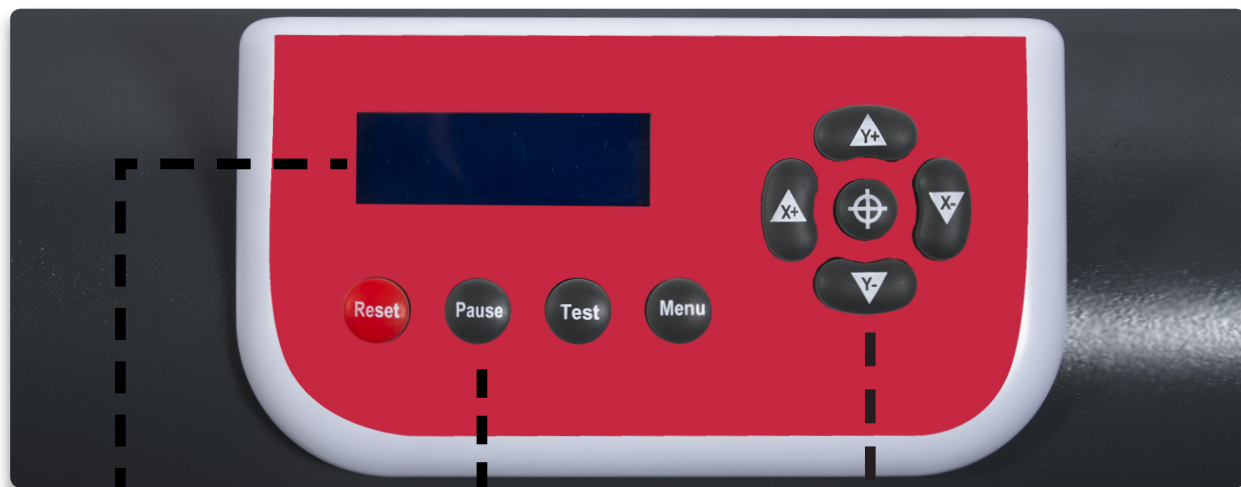

LCD Display

Input Controls

Navigation Control

SIDE VIEW



Power Plug Power Switch



Serial I/O USB I/O

INSTALLING VINYL MATERIAL

All Vinyl Systems cutters will have a 1" white tabs that are labeled on the cutter. These tabs are the areas your pinch rollers will need to be placed in. If you look underneath these white tabs, you will see that the metal roller will have traction which allows the vinyl to be fed with proper grip. If your pinch rollers are set up outside of these white tabs and clamped onto your vinyl, it is subject to shift when it is cutting since it will not have any grip. Try your best to make sure the pinch rollers are placed at the edge of your vinyl material. Sometimes if you have the pinch rollers too closely into the material, your vinyl will get bunched and possibly jammed.

STRAIGHTEN YOUR VINYL

Vinyl can be installed straight using the ruler that is labeled on the front of your machine. It is recommended to manually track out your vinyl forward using the control buttons before sending the job to ensure that it will be completely straight while it is cutting the entire size of your design. The last thing you'll want is your entire cut image to be ruined towards the end of the job just because you didn't measure it correctly!

PLACING YOUR CUTTER

If you are not using the included stand, make sure you place it on a sturdy tabletop or surface that will be able to support the weight and dimensions of your cutter. You will also need to make sure your vinyl roll will be able to feed correctly as improper feeding to the cutter will cause cut and tracking issues.

POWER ON YOUR CUTTER

These vinyl cutters require a standard US electrical outlet. They can draw up to 5 amps so make sure it is plugged into an outlet with enough power available. Connect the power plug to the wall socket when the machine is switched "OFF." Do not overload the circuit with any other electrical appliances. Most homes can hold anywhere from 15 to 20 amperages per breaker.

TAKING PRECAUTIONS

Make sure there are no objects that can obstruct the movement of the blade carriage when it is cutting. Sudden stoppage or obstruction can severely damage the motor.

REMOVE ALL LIQUIDS

Do not operate the vinyl cutter with any liquids or chemicals that could potentially spill onto the machine. This is a high risk of electric shock if the liquid is poured into the vinyl cutters power supply located on the side of the machine. Also make sure your hands aren't wet when using the vinyl cutter to avoid electrical shock.

BLADE HOLDER VS. PEN HOLDER

Due to the nature of a pen point, your pressure must be significantly lower when using the pen holder to plot instead of cutting. If your pressure is too high, you will ruin the pen instantaneously.

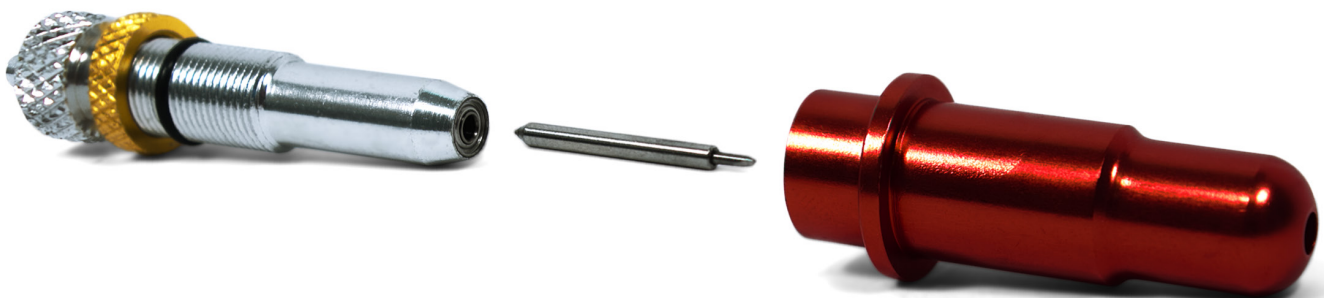

LET'S BUILD THE STAND

HERE IS WHAT YOU NEED TO BUILD THE STAND:

- Phillips head screw driver
- Crescent wrench

Build your stand using the following diagrams:

XL STAND SKETCH MAP

1: Back vinyl hanger 2: Column 3: Corssbeam
Install each components as number below to ensure the holes aligned and then fasten the screws.

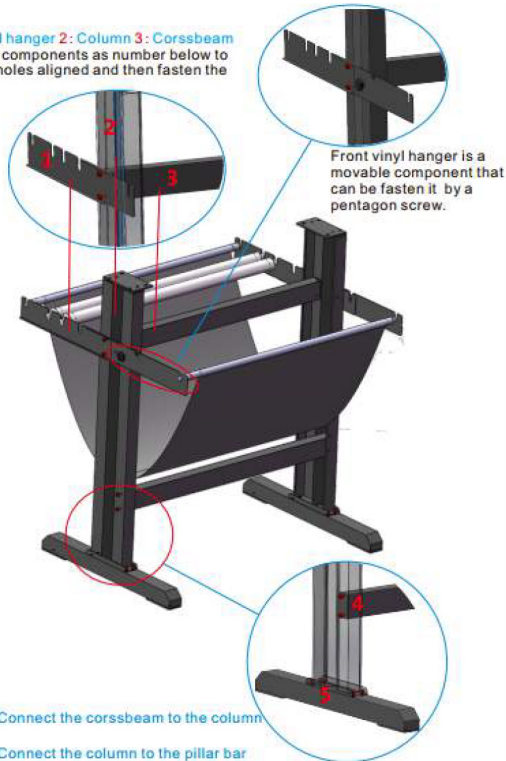

ALUMINUM STAND SKETCH MAP

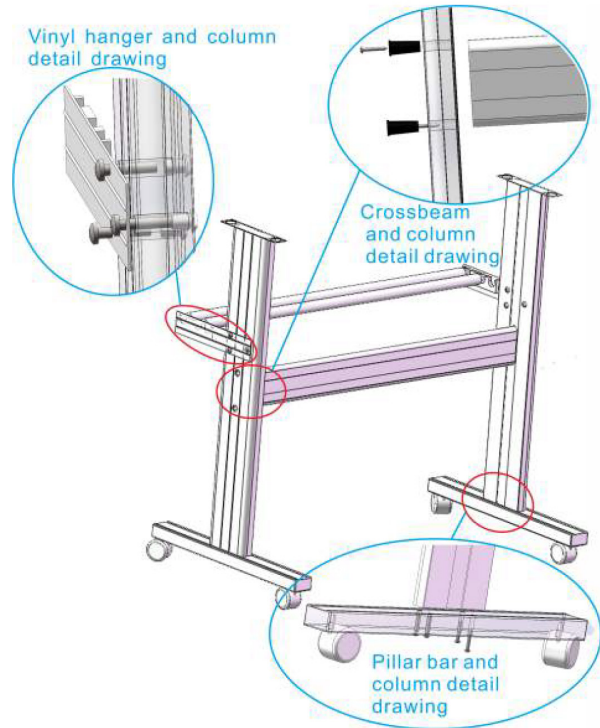

IRON STAND SKETCH MAP

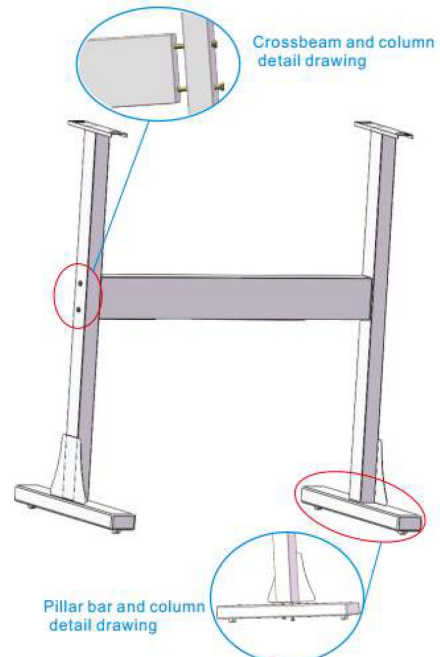

INSTALLING THE BLADE

The blade should be installed into the blade holder with the rounded/dull side into the holder with the sharp side sticking out. Push the blade eject button while you are inserting the blade so that it grabs the dull side in. You may push the blade eject button again if you are trying to replace your blade.

ADJUSTING THE BLADE DEPTH

Adjust your blade depth to the thickness of your vinyl material. If you are cutting standard heat transfer vinyl or window/decal vinyl, it should only be about the thickness of a piece of paper. If you are cutting thicker materials such as Glitter or Flock heat transfer vinyl, then you will need to increase the blade depth with the adjustment screw to about a credit card thickness.

TYPES OF BLADES

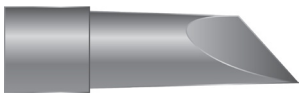

45 Degree

For cutting standard, thick fluorescent and reflective vinyl. This is your all around blade that allows you to cut in detail and for most thick items. This blade comes with all cutter models.

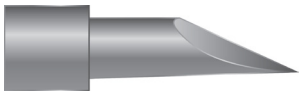

30 Degree

For cutting small text and fine detail. These more acute angle blades typically cut higher levels of intricacy in material that you would otherwise use a 45 degree blade for.

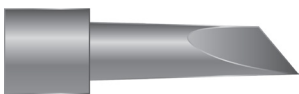

60 Degree

For cutting reflective vinyl, glitter vinyl, cardboard, sandblast, flock, and stencil sharp edge. Typically better for thicker material. This blade will prevent fewer lifted vinyl edges.

BLADE SET UP

BLADE HOLDER DIAGRAM

TOO SHORT

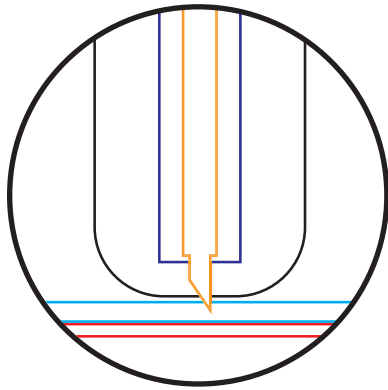

TOO FAR

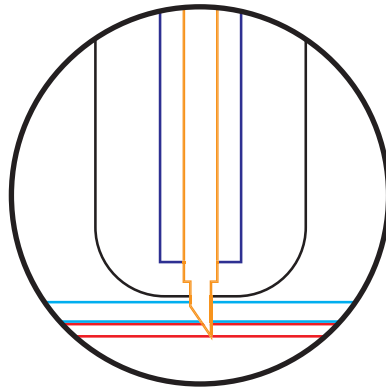

PERFECT

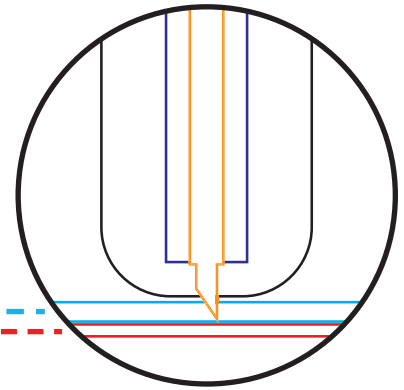

Vinyl
Pressure Sensitive Backing

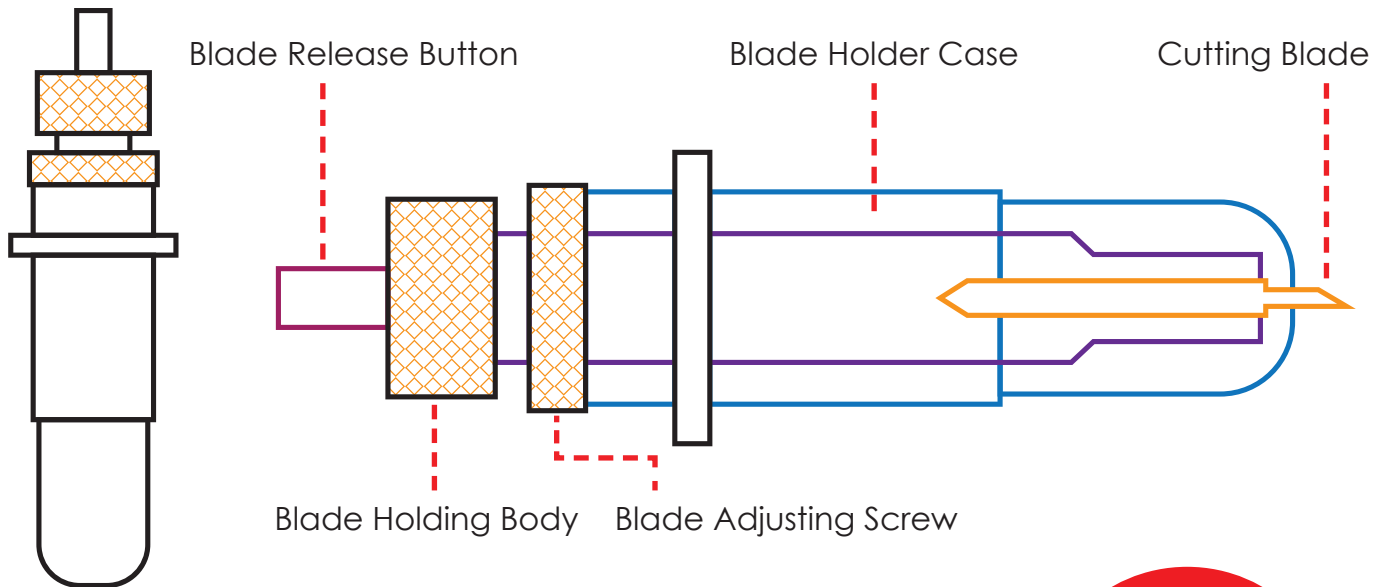

Do not insert the blade's sharp side into the holder. This will cause permanent damage to both components.

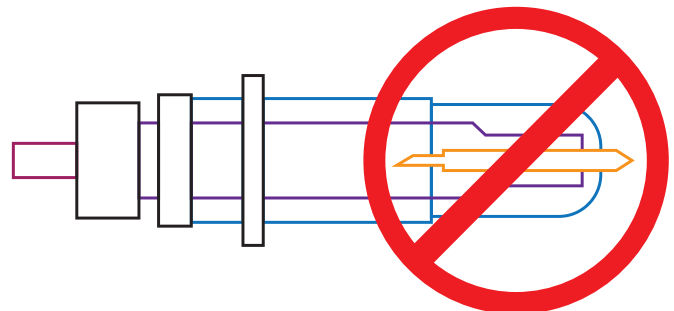

INSTALLING THE BLADE HOLDER INTO THE CARRIAGE

The blade holder will need to be installed into the carriage in this position with the eject button facing up and the blade facing down.

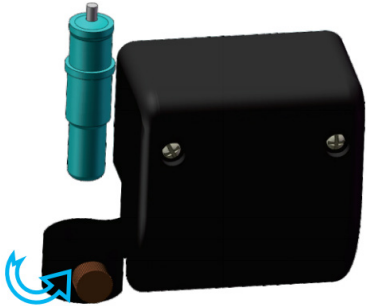

Interface Map

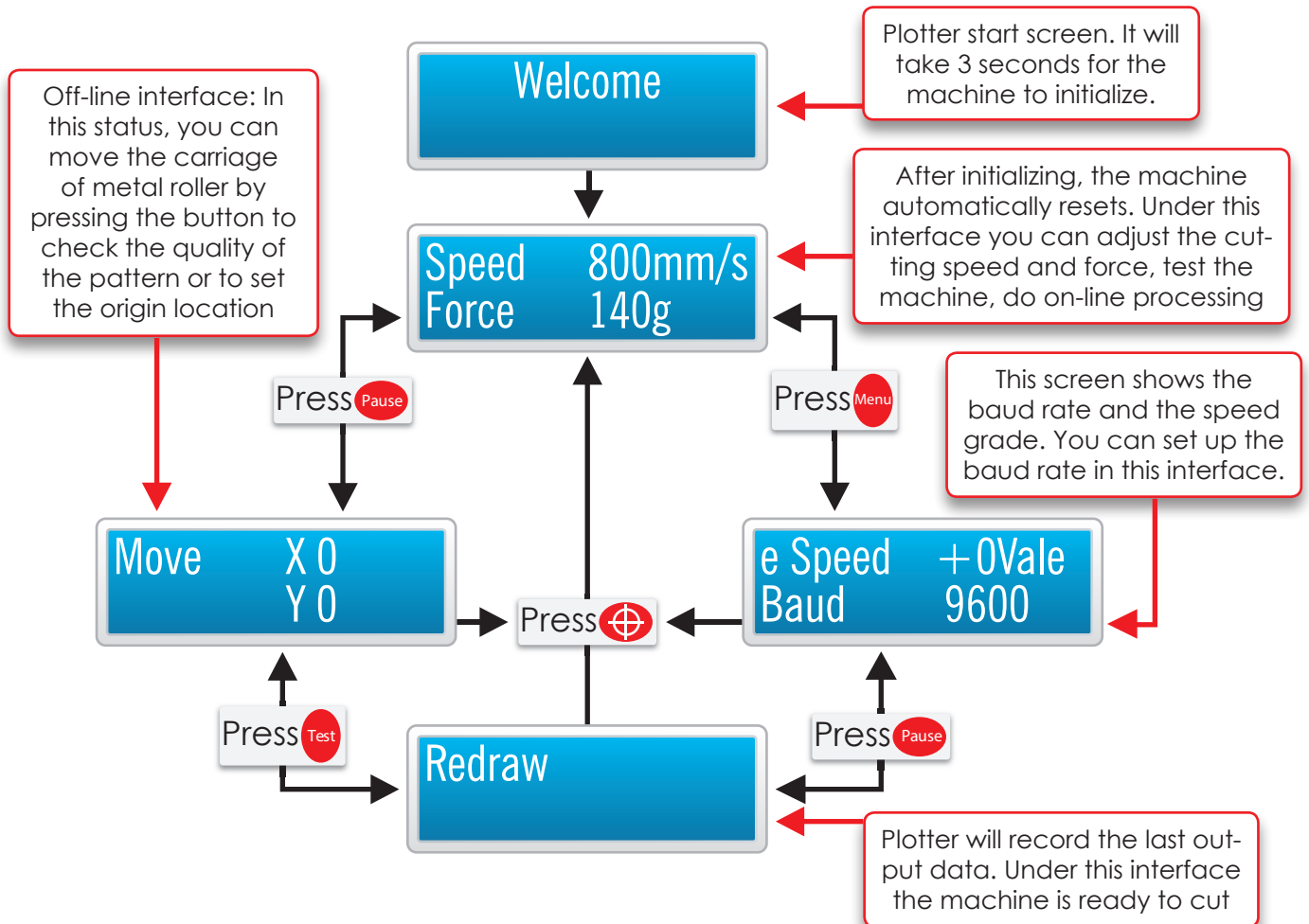

1. Welcome: This message will appear a few seconds after you turn on your vinyl cutter
2. Speed: This allows you to change the speed of how slow or fast your cutter will cut. Slower is recommended for more intricate, smaller, and detailed designs. Faster will be typically used for more largely scaled graphics that aren't as intricate. This allows you to speed up your production as needed.
3. Force: This allows you to change the pressure on how deep the vinyl cutter should cut your material. Please note, the blade should only be strong enough to cut the vinyl material alone without cutting the backing protective sheet.
4. Baud Rate: Is the rate at which information is transferred in a communication channel. Typically this isn't important unless you're setting up your cutter with the RS-232 Serial Cable. Since you are using it with USB. It will only transfer as fast as USB 2.0 will support which is instantaneously.
5. Redraw: This is also known as Recut. Which means it will cut the last job that was sent.

TROUBLESHOOTING

The completed cut is deformed or incomplete. Possibly missing a few parts of the design.

- Blade tip is too long, cutting force is too high, or cutting pad has worn and it has ridges from overuse.
- Software setting is incorrect. For example: tool compensation is open and the value is set too high.
- Metal roller screw or motor gear is loose (extreme case).

3 lights on gauge stay lit up.

- The mainboard has failed and will need to be replaced.

Vinyl cutter is cutting out of position.

- This can happen if you did not appropriately enter the correct width dimensions of your material in the software.
- Make sure your designs always fit within the size of your vinyl material by checking both length and width prior to cutting.

The designs aren't connecting at the end points. For example: When cutting a circle, the lines don't meet at the very end and sometimes possibly overlap.

- The blades are always pivoting at every point with the bearings built inside the blade holder. If your blade offset settings are misadjusted by the blade type you're using, your cuts won't connect.
- Your blade might be sticking out too far, therefore it is not able to pivot correctly in the holder.

The designs aren't connecting at the end points. For example: When cutting a circle, the lines don't meet at the very end and sometimes possibly overlap.

- The blades are always pivoting at every point with the bearings built inside the blade holder. If your blade offset settings are misadjusted by the blade type you're using, your cuts won't connect.
- Your blade might be sticking out too far, therefore it is not able to pivot correctly in the holder.

Corner of design is rounded instead of a sharp clean edge.

- Your blade offset needs to be increased. This is applicable when switching your blade to different angled tips.

The designs aren't connecting at the end points. For example: When cutting a circle, the lines don't meet at the very end and sometimes possibly overlap.

- The blades are always pivoting at every point with the bearings built inside the blade holder. If your blade offset settings are misadjusted by the blade type you're using, your cuts won't connect.
- Your blade might be sticking out too far, therefore it is not able to pivot correctly in the holder.

Corner of design is rounded instead of a sharp clean edge.

- Your blade offset needs to be increased. This is applicable when switching your blade to different angled tips.

Corner of design is rounded instead of a sharp clean edge.

- Your blade offset is too high and will need to be decreased. This is applicable when switching your blade to different angled tips.

Multiple improper slashes on your vinyl or diagonal cuts across your design.

- Blade is sticking out too far. The blade carriage will lift the holder when it is trying to cut in different area. If the blade is too far out, what happens is it drags the blade across the vinyl when it is lifted.

Vinyl bunches up and gets jammed during the cutting process. Sometimes the vinyl shifts when it is cutting.

- This can happen when your pinch rollers are not set at the appropriate position. The pinch rollers should be set underneath the white tabs where the metal roller has grip. This grip allows the vinyl to be fed correctly when it is tracking back and forth. Also, you must have them positioned at the edge of your vinyl or else the blade will jam the vinyl into the pinch roller when cutting a design that is wider than where the pinch roller is positioned.
- If problem persists, your pinch roller could possibly be damaged. Check to see if there are any cracks or damages. This would negate the tension it is supposed to provide.

BLADE

The blade is your bread and butter with any vinyl cutter. All Vinyl Systems cutters come equipped with a 45 degree angle blade. We would recommend replacing the blade every 6-12 months of continuous use. This can vary depending on the type and thickness of your material.

CUTTING PAD

The cutting pad is essentially the white strip your blade makes indirect contact with when it is cutting through your material. This cutting pad can typically last about 6-12 months of continuous use before it will need to be replaced. One way you will notice an issue is when your designs start to have missing parts or it starts to cut away from the vector path.

BLADE HOLDER

The blade holder uses bearings inside that allows the blade to pivot when it is cutting corners, edges, and circles. These bearings can wear down over time which means you will have to replace the entire blade holder. A blade holder should usually last you over 1-2 years of continuous use. Only replace this if you have replaced the blade, corrected the offset settings, replaced the cutting pad, and are still having issues with finished cuts.

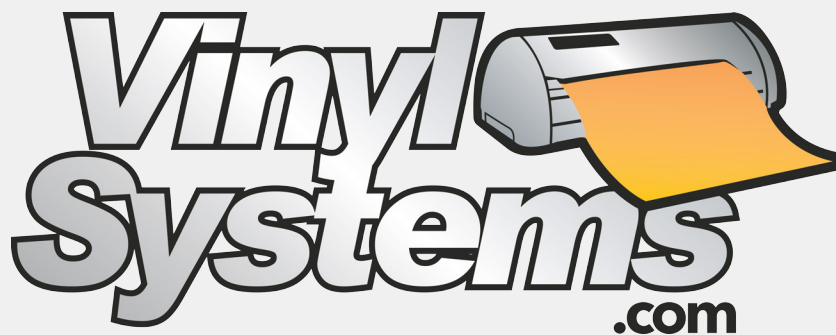

You may purchase all of these accessories and supplies at www.vinylsystems.com

Vinyl Systems provides lifetime free technical support for all vinyl cutters purchased through us. Our technicians use TeamViewer's remote control support for the easiest way to support you all the way through!

If you feel unsure using or you have any questions about your cutter and software, please download www.vinylsystems.com/teamviewer and give us a call at (800)664-8090.

Notes:

SAWGRASS™

MPRESS®
Heat Transfer Solutions

GCC

Specialty
Materials™

PAROPY™
image trans

HeatPress.com
HeatPress
Nation

ChromaLuxe®

GEO Knight & CO, INC
EST. 1988

Chemica
Transfer your imagination

vapor™
apparel

Siser®
Thermo Transfers for Textiles

ORACAL®

FOREVER®
DIGITAL TRANSFER APPLICATIONS TECHNOLOGY

silhouette

ENGINEERED to PERFORM BETTER.™

INSTA
INSTA GRAPHIC SYSTEMS

OKI
PRINTING SOLUTIONS

HIX CORPORATION

GRAPHTEC
GRAPHTEC AMERICA, INC.

AlbaChem®

EPSON®
EXCEED YOUR VISION

GREAT DANE
GRAPHICS

beaver paper
& Graphic Media, Inc.



STAHL'S
Hotronix®

SOFTWARE VINYL SIGNS & CONTOUR CUTTING
SIGNMASTER

WinPCSIGN
design | prepare | cut

unisub®

Copyright © 2016 Viny Systems

All rights reserved. No part of this publication may be reproduced, distributed, or transmitted in any form or by any means, including photocopying, recording, or other electronic or mechanical methods, without the prior written permission of the publisher, except in the case of brief quotations embodied in critical reviews and certain other noncommercial uses permitted by copyright law. For permission requests, write to Vinyl Systems, 1050 W Central Ave., Unit B Brea, CA 92821