



PILATES PRO CHAIR™
BY LIFE'S A BEACH, INC.



CHAIR ASSEMBLY & CARE GUIDE



▲ For maximum effectiveness and safety, read instructions and important tips before using the Pilates PRO Chair™.

- important safety information
- assembly instructions
- use and care

IMPORTANT SAFETY INFORMATION

CAUTION: To avoid injury, follow the safety information in this document. To reduce the risk of product damage, imbalance, pinch points, choking, and strain due to misuse, follow these instructions.

- Consult your physician before starting this or any exercise program. Stop and consult your physician if at any time during exercise you feel faint, dizzy, or experience pain.
- Do NOT use the Pilates PRO Chair™ as a toy. Keep it and all accessory pieces away from children at all times. The Pilates PRO Chair™ contains small parts that could cause choking.
- Do not exceed the maximum user weight of **300lbs.**
- Inspect the Pilates PRO Chair™ for damage before use. If you find any missing or damaged parts, discontinue use.
- Use the Pilates PRO Chair™ for home exercise only. It is NOT intended for commercial use.
- Use only the exercises described in the Pilates PRO Chair™ exercise instructions.
- Avoid straining your neck during workouts. Do not turn your head to look at the Pilates PRO Chair™ DVD on your TV screen. Keep your head facing forward at all times, and listen for the cues; or turn your chair to face the screen.
- Control the springs. Maintain constant tension on the springs of your Pilates PRO Chair™ when exercising so that the work out foot pedals do not snap back into place or crash to the floor and cause bodily injury.
- Be aware of your foot placement. Never place your feet under the pedals, where they could be crushed.
- Keep fingers, loose clothing, and hair away from all moving parts.
- Do all workouts in bare feet to avoid injury due to slipping and to avoid possible damage to the Pilates PRO Chair™ unit. Do not use while wearing socks or shoes.
- Use the Pilates PRO Chair™ only on stable and even surfaces.
- Use the arm handles only when seated.
- Open the Pilates PRO Chair™ legs fully, and lock them into position prior to use.
- Fold and lock the Pilates PRO Chair™ before transporting it.

USE/ASSEMBLY INSTRUCTIONS

The Pilates PRO Chair™ comes partially assembled (Figure 1):

figure 1

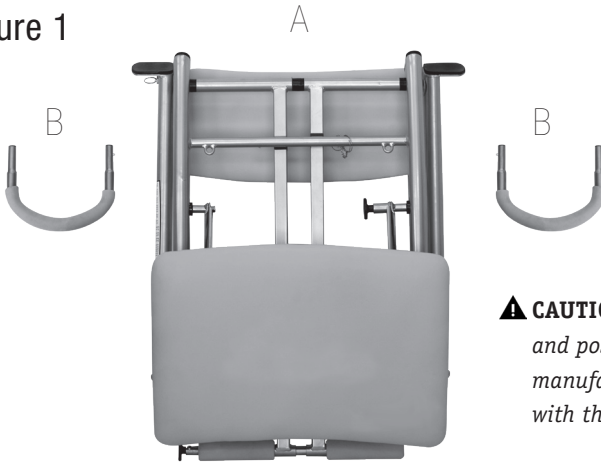

⚠ CAUTION: To avoid breakage and possible injury, use only manufacturer-supplied parts with the Pilates PRO Chair™.

To complete the assembly of the Pilates PRO Chair™, you will need the following items, which are all included in your shipment (see **Figure 2**):

- Pilates PRO Chair™ base (A)
- 2 Arm handles (B)
- 2 Springs (C)
- Foot board (D)
- Pedal locking pin (E)
- Leg safety lock (F)
- Bracket curves (G)
- Workout foot pedal (H)
- Foot board pin (I)
- Toggle (J)

figure 2

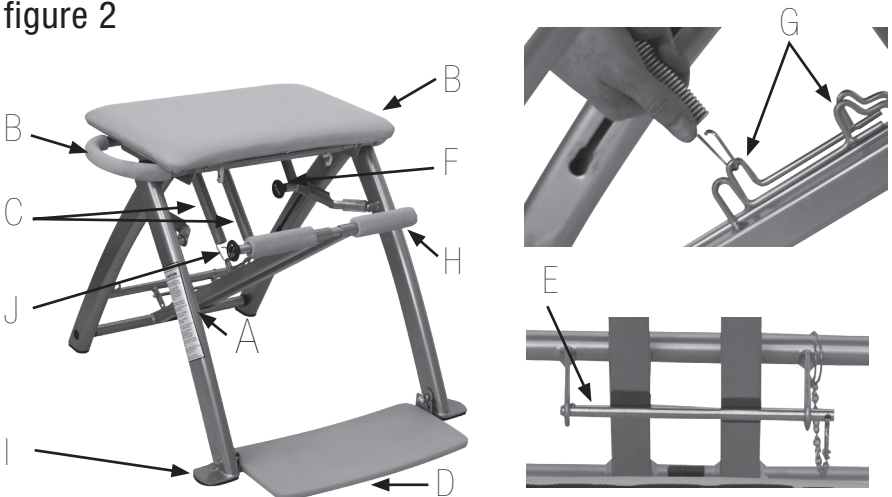

ASSEMBLING THE PILATES PRO CHAIR™ BASE

STEP 1 Carefully remove the Pilates PRO Chair™ parts from the plastic bags.

NOTICE: Do not use sharp objects to cut through the plastic bags. Doing so may cause damage to the Pilates PRO Chair™ parts.

figure 3

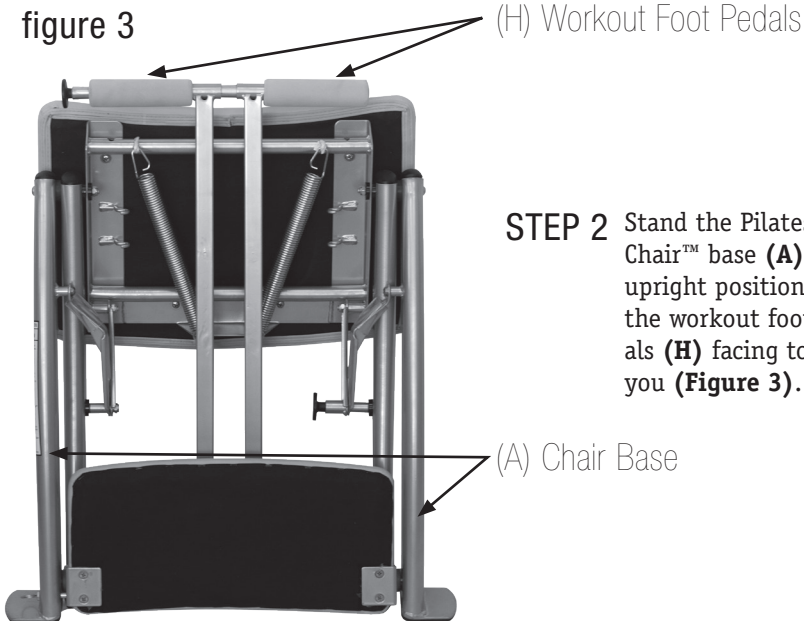

STEP 2 Stand the Pilates PRO Chair™ base (A) in an upright position with the workout foot pedals (H) facing toward you (Figure 3).

STEP 3 Push in the Leg Safety Lock (F). Grasp the legs closest to the foot board, and pull them away from the opposite legs until they lock into place (Figure 4).

figure 4



STEP 4 Make sure the leg safety lock **(F)** is secure **(Figure 5)**.

figure 5

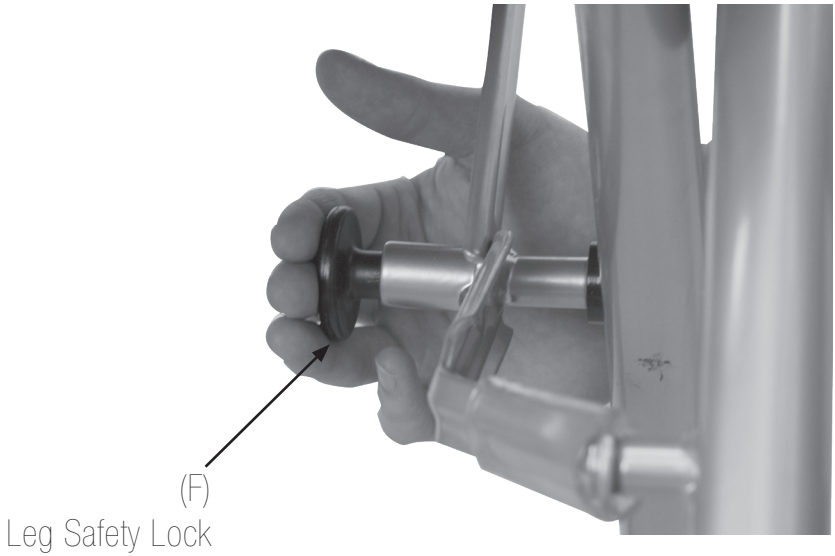

figure 6



▲ CAUTION: *Open the legs of the Pilates PRO Chair™ fully and lock them into position prior to use, (Figure 6).*

FOLDING THE FOOT BOARD DOWN

The Pilates PRO Chair™ comes with the foot board **(D)** locked in the up position **(Figure 7)**.

figure 7

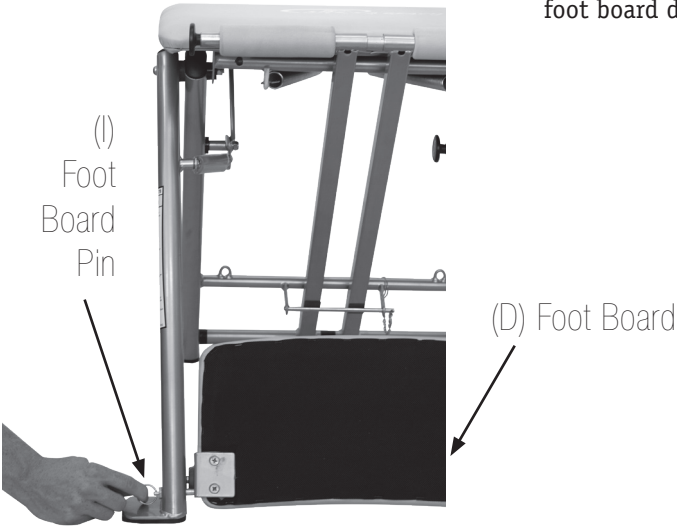

STEP 1 Pull the foot board pin **(I)** out, **(Figure 7)**, and fold the foot board down.

STEP 2 Release the foot board pin **(I)**. The foot board **(D)** is now locked into the down position **(Figure 8)**.

figure 8

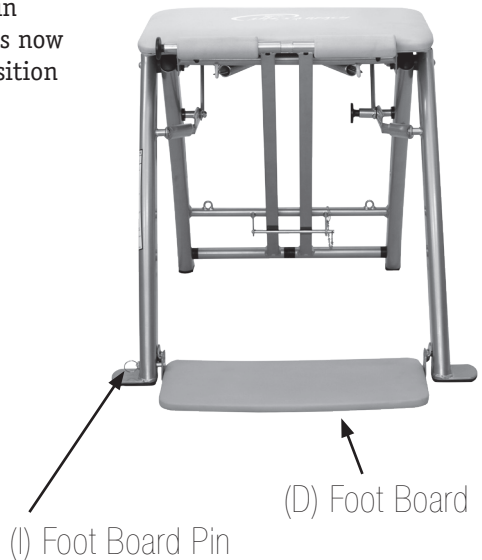

FOLDING THE PEDALS DOWN

STEP 1 Remove the pedal locking pin **(E)** from the bracket on the cross-bar at the back of the workout foot pedals **(H)**, as shown in **Figure 9**, and release the foot pedals **(H)** down **(Figure 10)**.

figure 9

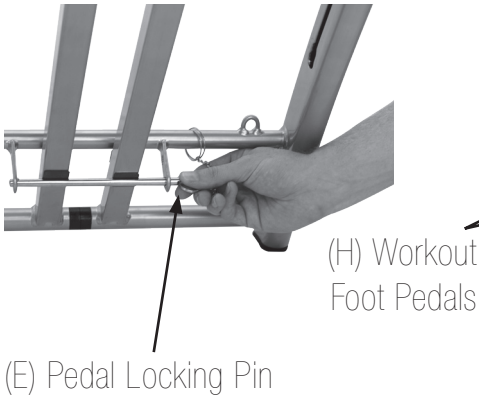
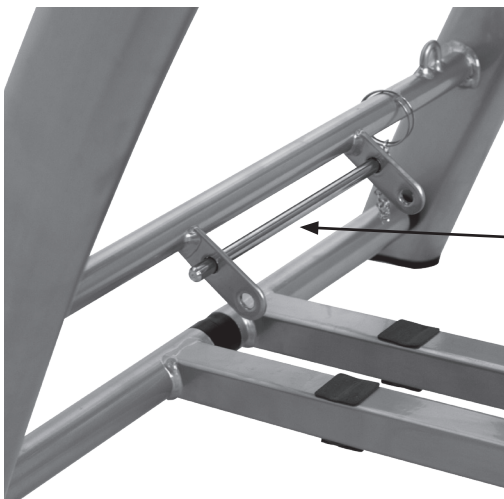

figure 10



figure 11



STEP 2 Place the pedal locking pin **(E)** in the top holder of the bracket on the cross-bar at the back of the foot pedals **(H)** for safe keeping **(Figure 11)**.

(E) Pedal Locking Pin

ATTACHING THE ARM HANDLES

STEP 1 Hold one arm handle **(B)** at the curved end, and align the straight ends with the chair seat holes (**Figure 12**).

figure 12

(B) Arm Handle



STEP 2 Push in the round button on the arm handle's **(B)** straight end as you slide the handle into the chair seat holes (**Figure 13**).

figure 13

Round button



STEP 3 Continue pushing the arm handle **(B)** in until you hear a click and the round button pops out of the adjoining hole (**Figure 14**). The arm handle is now securely in position.

figure 14

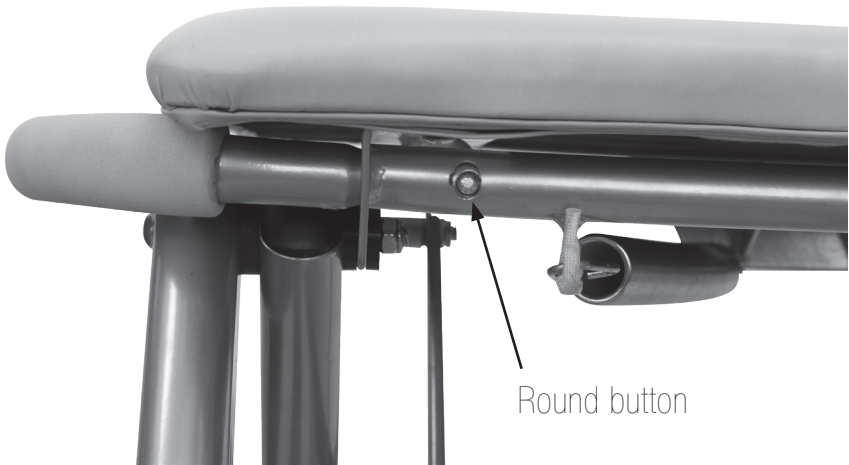

STEP 4 Repeat Steps 1-3 with the second arm handle.

ATTACHING THE SPRINGS

STEP 1 Unhook both springs **(C)** from the stored position underneath the chair seat **(Figure 15)**.

figure 15

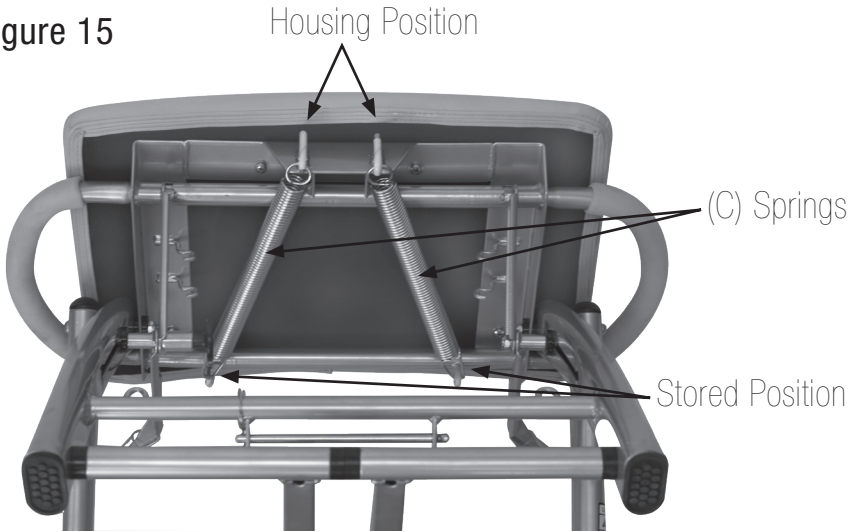

NOTICE: When the Pilates PRO Chair™ is not in use, return the springs **(C)** to the stored position **(Figure 15)**.

NOTICE: Never detach the springs **(C)** from the housing position **(Figure 15)** on the Pilates PRO Chair™. Doing so may cause damage to the chair.

STEP 2 Locate the two thin, curved brackets **(G)**, one on each workout foot pedal **(Figure 16)**.

figure 16

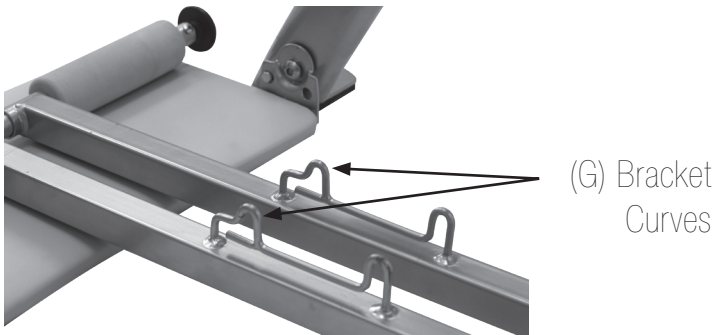

STEP 3 Put one springs **(C)** triangular hook in the bracket curve **(G)** closest to the pedal locking pin **(E)** (**Figure 17**).

NOTICE: Do not rotate the spring when attaching it to the bracket curve, to avoid damage to the spring.

figure 17



STEP 4 If the exercise instructions tell you to use only one spring **(C)**, do not proceed to Step 5.

STEP 5 Repeat Step 3 with the second spring **(C)**, on the opposite foot pedal **(H)**, putting it in the bracket curve **(G)** closest to the pedal locking pin **(E)**. See **Figure 18**.

figure 18

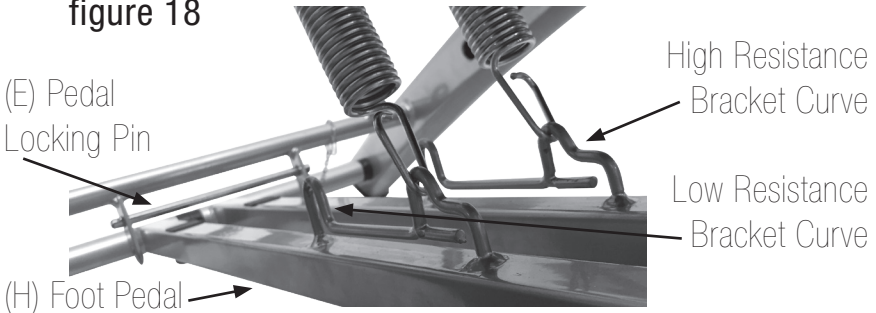

NOTICE: When both springs **(C)** are attached to the brackets closest to the side of the chair with the pedal locking pin **(E)**, you are operating at the Low Resistance Level. When both springs **(C)** are attached to the brackets closest to the side of the chair with the foot board **(D)**, you are operating at the High Resistance Level.

NOTICE: To learn how to change resistance levels, see the section "Adjusting the Springs for Low Resistance and High Resistance."

SPLITTING THE WORKOUT FOOT PEDALS FOR SPECIFIC PILATES PRO CHAIR™ EXERCISES

▲ CAUTION: Before proceeding with Step 1, make sure the springs (C) are attached to both workout foot pedals (H). See the section "Attaching the Springs."

STEP 1 Push in the toggle (J) on the workout foot pedal (H).

STEP 2 Pull the toggle (J) clockwise (Figure 19) and then release it. The workout foot pedal (H) is now split into two pedals (Figure 20).

figure 19

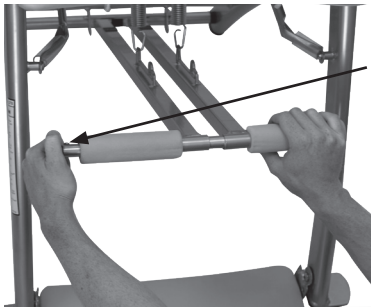

figure 20



RECONNECTING THE WORKOUT FOOT PEDALS

STEP 1 Align the workout foot pedals (H) together and push in the toggle (J) (Figure 21).

STEP 2 Turn the toggle (J) clockwise. The pedals are now reconnected (Figure 22).

figure 21

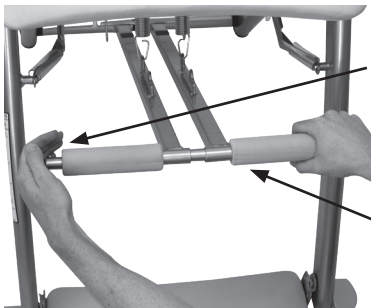
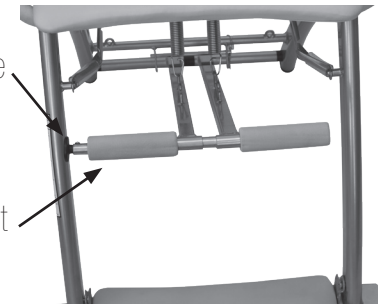

figure 22



ADJUSTING THE SPRINGS FOR LOW RESISTANCE AND HIGH RESISTANCE

STEP 1 To adjust the springs **(C)** from one resistance level to another, unhook one spring at a time **(Figure 23)**, and hook the springs **(C)** into the opposite bracket curves **(G)** **(Figure 24)**. Make sure both springs **(C)** are secure.

figure 23



(C) Spring

Low Resistance
Bracket Curve

figure 24

(E) Pedal
Locking Pin



High Resistance
Bracket Curve

NOTICE: When both springs **(C)** are attached to the brackets **(G)** furthest from the side of the chair with the workout foot pedal **(H)**, you are operating at the **Low Resistance Level**. When both springs **(C)** are attached to the brackets **(G)** closest to the side of the chair with the workout foot pedal **(H)**, you are operating at the **High Resistance Level**.

NOTICE: When the Pilates PRO Chair™ is not in use, return the springs to the stored position **(Figure 25)**.

NOTICE: Never detach the springs **(C)** from the housing position **(Figure 25)** on the Pilates PRO Chair™. Doing so could cause damage to the chair.

FOLDING AND STORING THE CHAIR

STEP 1 Unhook both springs **(C)** from the bracket curves **(G)**, and return them to their original stored position underneath the chair seat **(Figure 25)**.

figure 25

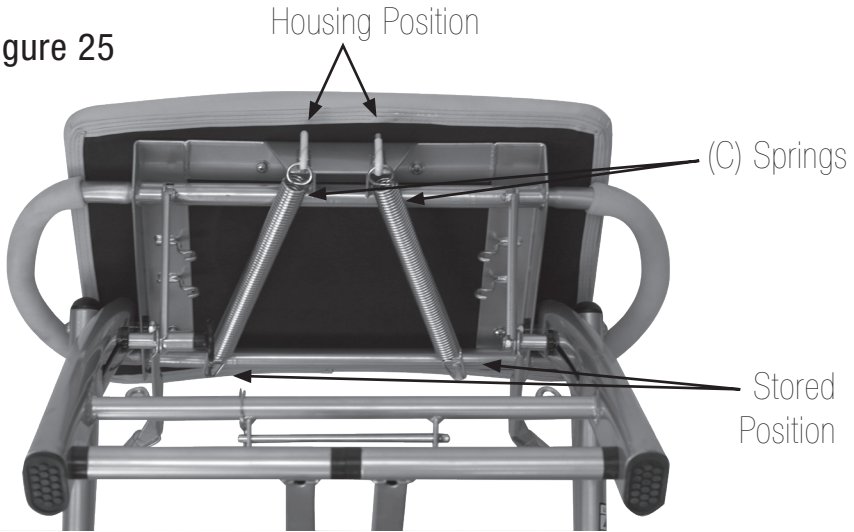

NOTICE: When the Pilates PRO Chair™ is not in use, return the springs **(C)** to the stored position **(Figure 25)**.

NOTICE: Never detach the springs **(C)** from the housing position **(Figure 25)** on the Pilates PRO Chair™. Doing so could cause damage to the chair.

STEP 2 Remove the pedal locking pin **(E)** from the storage in the bracket. **(Figure 26)**.

figure 26

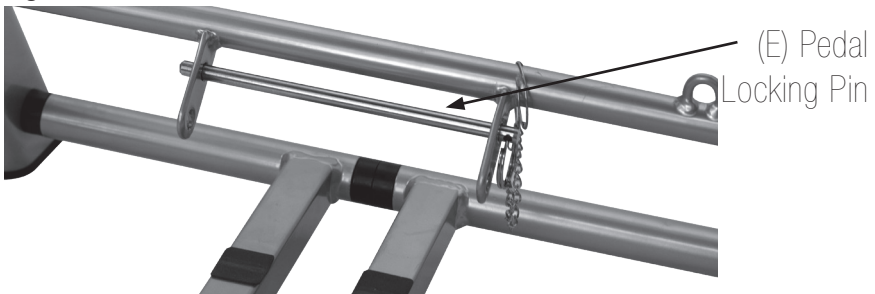

STEP 3 Raise the workout foot pedals **(H)** up, and insert the pedal locking pin **(E)** into the second hole of the bracket so that the legs are stored securely **(Figure 27)**.

▲ CAUTION: To avoid pinch points, make sure the pedal locking pin **(E)** is in the locked position, as shown in **Figure 27**, before moving or storing the Pilates PRO Chair™.

Both legs are now secure **(Figure 27)**.

figure 27

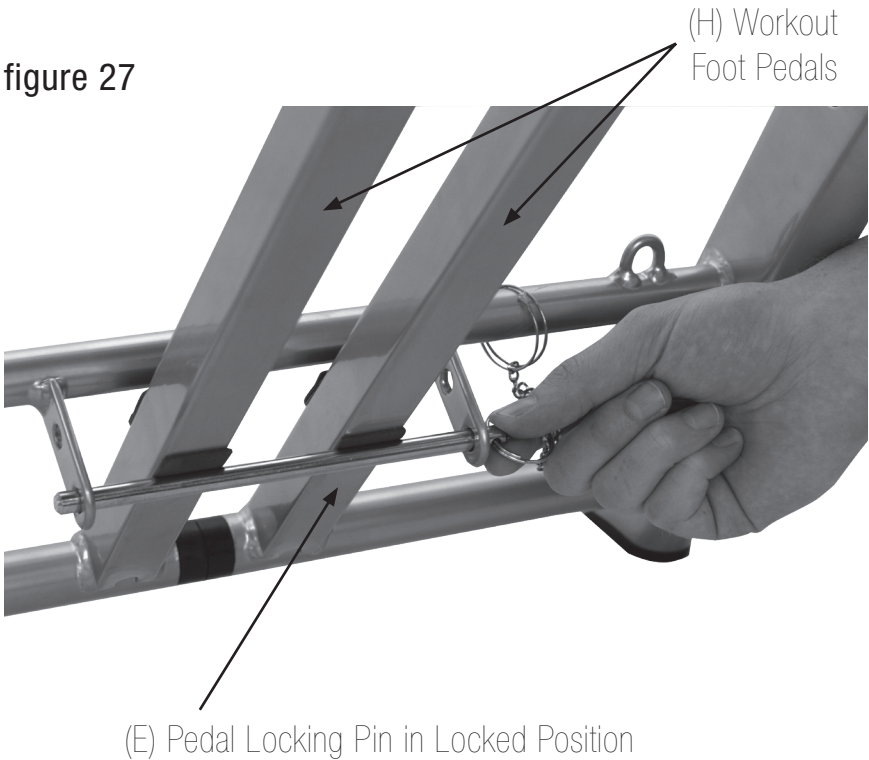

FOLDING AND STORING THE CHAIR *(continued)*

STEP 4 Pull the foot board pin **(I)** out **(Figure 28)** and fold the foot board **(D)** up. Release the foot board pin **(I)** so that the foot board **(D)** is locked into the storage position **(Figure 29)**.

figure 28

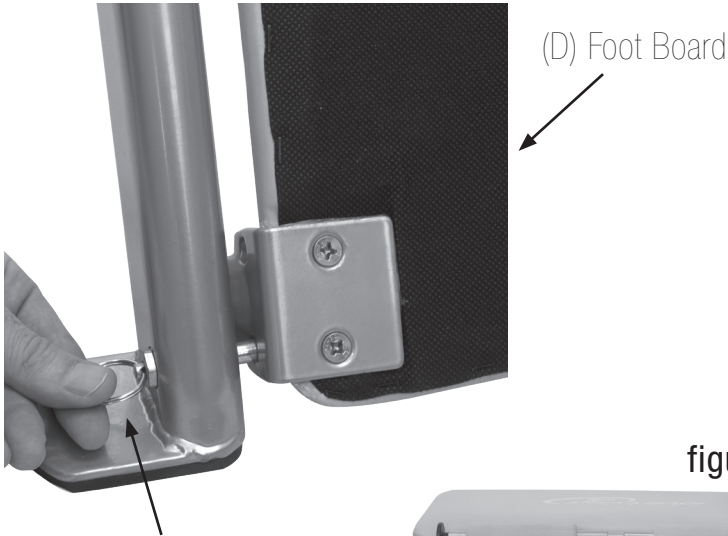

(I) Foot Board Pin

figure 29



(I) Foot Board in Storage Position

STEP 5 Push in the leg safety lock **(F)** (**Figure 30**).

figure 30

(F) Leg Safety Lock

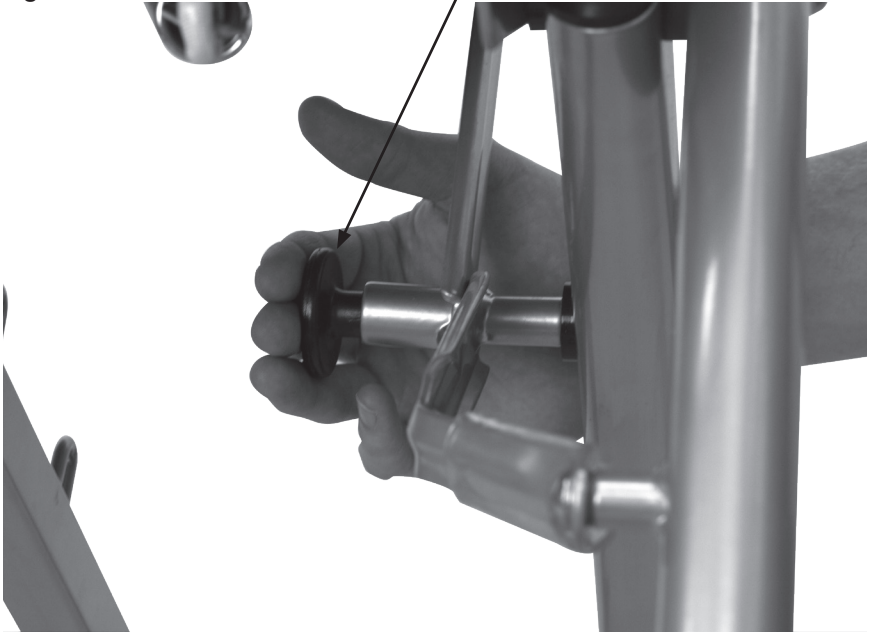

FOLDING AND STORING THE CHAIR *(continued)*

STEP 6 Keep pushing in the leg safety lock **(F)** while slowly folding both sets of chair legs together **(Figure 31)**. Make sure the legs are fully closed and the leg safety lock **(F)** is secure.

figure 31



NOTICE: The Pilates PRO Chair™ is meant to be stored in a flat position, as shown in *Figure 32*.

figure 32

The chair is now in the full storage position **(Figure 32)**.

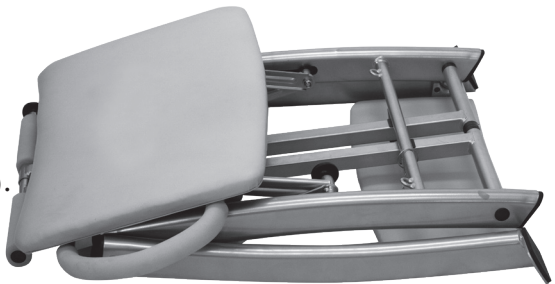



CARING FOR YOUR PILATES PRO CHAIR™

- Clean the Pilates PRO Chair™ with a soft, damp cloth only. Do not use soap or harsh chemicals.

TIPS FOR MAXIMUM BENEFITS

- Perform the exercises slowly and with control.
- Use the Pilates PRO Chair™ only as intended and demonstrated in the Pilates PRO Chair™ exercise instructions.
- The training provided in the exercise instructions is in no way intended as a substitute for medical counseling.



PILATES PRO CHAIR™
BY LIFE'S A BEACH, INC.

© 2015 Life's A Beach, Inc.™
All Rights Reserved.
www.pilatesprochair.com
LAB03001