

# Dual Point Booster Data Sheet Back Entry

## Certified to AS/NZS 2419.3

- » High Strength, Premium Quality Dual Booster Assembly
- » Stainless Steel Booster Body, Inlet Connection, Seating Disc, Spring, Drain Valve & Pressure Gauge
- » High Corrosion Resistance
- » Oil Filled Pressure Gauge
- » Long Service Life
- » Comes with Pressure Gauge, Drain Valve, Dust Cap & Chain
- » Class PN 21 High pressure booster valve
- » Fully Tested and Approved to AS2419.3-2012



Stock Code	Body Type	Inlet Connection	Height	Width	Weight
TBRG100-BACK	Dual Booster - Bottom outlet	65mm STORTZ	250mm	343mm	7.9kg
<b>Material</b>					
» Booster Body	Stainless Steel Grade 304				
» Inlet Connection	Stainless Steel Grade 304/Forged Alloy for Stortz model				
» Pressure Gauge	Stainless Steel Grade 304 with oil filled				
» Drain Valve	Stainless Steel Grade 304				
» Disc Facing	NBR Rubber				
» Blank Cap	UV Stabilized Plastic				
<b>Working Pressure</b>	<b>Maximum Working Pressure</b>	<b>Onsite Test Pressure</b>			
2,100 kPa	2,650 kPa	3,150 kPa			

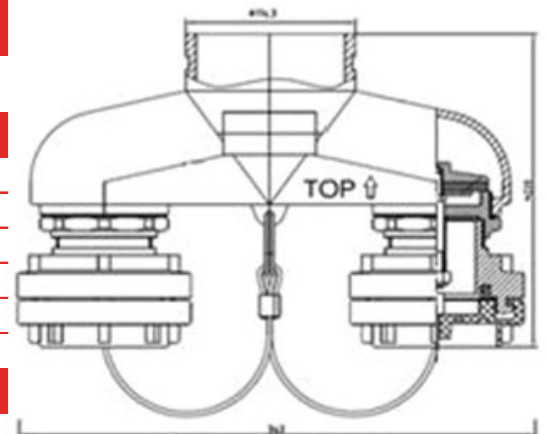

**A** 1/32 Stennett Road, Ingleburn NSW 2565  
**P** (02) 9618 7666  
**E** sales@ausfiregroup.com.au  
**W** ausfiregroup.com.au