



REID

BICYCLE OWNERS MANUAL



YOU SHOULD READ THIS MANUAL

- YOUR BICYCLE IS LEGALLY A VEHICLE.
- IT CAN BE RIDDEN ON ROADS MIXING WITH OTHER TRAFFIC.
- YOU NEED TO KNOW ABOUT CERTAIN LEGAL AND COMMON SENSE REQUIREMENTS FOR THE ENJOYABLE, SAFE AND TROUBLE FREE USE OF YOUR BICYCLE.

LIMITED WARRANTY: REID steel and aluminium alloy frames and forks come with a lifetime warranty against defects arising from normal use. The frame and fork warranty offered by REID is conditional on the bicycle being professionally serviced every 12 months from date of purchase as a minimum. Evidence of servicing must be available upon request should a warranty claim arise.

All other REID components are warranted against failure or defect arising from normal use for 2 years from the date of purchase. Tyres, tubes, brake shoes and cables are excluded from this warranty. Shipping and labour charges are not included in this warranty. REID will replace or repair at their discretion any frame found to be defective in materials or workmanship. Replacements will be made with frames of current design that may not be exact duplicates of originally purchased goods. The frame model used for replacement will not be lower in value than the original frame. This warranty gives you specific rights

in addition to other rights you may have. These rights may vary from state to state. Which the consumer has under the trade practices act and other state and territory laws.

EXCLUSIONS: The warranty, or any implied warranty, does not cover normal wear and tear and all warranties are void if the bicycle is used for other than normal activities such as but not limited to stunt riding. Occasionally bicycles are involved in accidents. Repairs or replacements required where there is evidence that such conditions have contributed to a component failure, will not be covered by the warranty.

NOTICE: The user assumes all risks for any personal injuries, damage to or failure of the bicycle and other losses if this REID bicycle is used in any competitive event, including, but not limited to, bicycle racing, dirt biking or similar activities, or training for such activities. Do not use REID bicycles for stunt riding, ramp jumping, acrobatics or similar activities, or with motors as power-driven vehicles. This warranty does not cover any personal injuries, damage to or failure of the bicycle or any other losses due to accident, misuse, neglect, abuse, normal wear, improper assembly or improper maintenance. This warranty does not cover commercial use of the bike.

Contact YOUR RETAILER for Service and Replacement - Claims under this warranty should be made to YOUR RETAILER with dated proof of purchase, and said supplier will determine if the component(s) is defective. Any defective part will be replaced free of charge. Installation labour is not included in this warranty. This warranty is extended to the original owner only and does not cover any defect, malfunction or failure which does not conform to the limited warranty aforesaid.

All warranty claims should be dealt with your retailer . For a full list visit www.reidcycles.com.au

All information is correct at time of going to press as at Oct. 2014. We reserve the right to update the warranty on our products. Any future changes will be available at www.reidcycles.com.au

CONTENTS

You should read this manual	2
Owner's information and responsibility.	2
What kind of bicycle is it?	3
What is it called?	5
Section 1: Safety Precautions	
1.1 Fitting your bicycle for a safe ride.	6 1.2
Safety check before riding your bicycle	9 1.3
Safety equipment and sensible riding.	10
Section 2	
How things work	14
Section 3: Service and Basic Maintenance	
3.1 Maintaining your bicycle	30 3.2
Monthly service chart	31
Additional Information:	
Helpful hints, Special Instructions and Warranty	
4.1 About your bicycle retailer	34 4.2
Special instructions for care of carbon fibre bicycles	34 4.3
Tools and bicycle assembly	35 4.4
Lock your bicycle	37 4.5
Keep a record of your bicycle	38
Troubleshooting chart	39
Bicycle record chart	42

Acknowledgments

This Manual has been developed by BIA Ltd.

Illustrations reproduced courtesy of BIA member Companies.

The information contained in this Manual complies with relevant Australian Standards at the time of printing. This Manual may not be reproduced without the express and written permission of BIA Ltd.

Bicycle Industries Australia Ltd. ABN 84 094 666 538

Bicycle Industry of Australia on the Web: www.bikeoz.com.au

YOU SHOULD READ THIS MANUAL

Your bicycle is legally a vehicle. It can be ridden on roads mixing with other traffic. You need to know about certain legal and common sense requirements for the enjoyable, safe and trouble free use of your bicycle.

OWNER'S INFORMATION AND RESPONSIBILITY

To reduce the risk of serious personal injury, you should read the instructions in this manual carefully.



There are **warnings** throughout this manual. Follow all warning instructions. Don't risk injury, mechanical failure or damage.

Your bicycle has been supplied fully assembled and adjusted ready for use. This manual is not an 'assembly instruction'. If your bicycle has been supplied in a form not ready for use you must obtain "assembly instructions" from your supplier.

Return your bicycle for an initial service by your bicycle retailer to ensure correct functions of components. The owner or main rider is then responsible for normal maintenance of the bicycle to keep it in good operating condition.

Know how to operate all standard and accessory equipment on the bicycle.

Ensure that anyone who uses the bicycle has been fully instructed in the operation of bicycle functions.

Your bicycle conforms to relevant Australian Standards. Other local regulations may apply. Check with your bicycle retailer.

Many bicycle product manufacturers and suppliers provide additional information on Web sites.

The Bicycle Industry in Australia Web site includes many useful links and other information at: www.bikeoz.com.au

The Cycling Promotion Fund offers helpful hints and links at: www.rideabike.com.au

WHAT KIND OF BICYCLE IS IT?

Bicycles can be broadly categorised into four types:

- Road or Touring
- Mountain or Off Road
- Cross, Hybrid, City or Comfort
- BMX
- Freestyle

Bicycles for younger riders use are generally scaled down versions of adult bicycles including the step through design. Other bicycles include tandems, recumbents and folding bicycles. Which type is your new bicycle?

ROAD OR TOURING

Typically has narrow tyres and drop handlebar.

Variations include bicycles suited for touring, commuting, sports, and recreational riding.

MOUNTAIN OR OFF ROAD

The Mountain Bicycle is designed to give the rider maximum control and durability on a wide variety of harsh terrain. Everything about the Mountain Bicycle is more rugged. Its frame geometry provides maximum ground clearance and allows you to quickly and easily shift your weight to change the balance of the bicycle as terrain conditions demand.

WARNING: Not all Mountain type bicycles are intended for off road or competition use. Check specifications and technical advice from your bicycle retailer before use.

CROSS, HYBRID, CITY OR COMFORT

Usually something of a mixture of characteristics of the Road and Mountain types but may include evolving frame shapes and components. Suited for general purpose riding.



BMX

BMX, are general purpose bicycles for younger riders.

The BMX type Bicycle is a versatile machine usually of 20" (510mm) or less sized wheels with wide section tyres, ideal for general purpose use by younger riders.



WARNING: General purpose Freestyle and BMX bicycles are not designed for stunting, racing or competition use.

FREESTYLE

Modelled on a trick riding style machine, featuring 360 degree revolving handlebar/fork assembly, axle pegs and wide profile tyres. Using a freestyle type bicycle for trick or competition riding may void warranty.

POWER ASSISTED BICYCLES

Have characteristics and equipment which may require special instruction, adjustment, care and maintenance. Read carefully all instruction manuals. Ask your bicycle retailer for advice on maintenance, adjustments and repair.

Unauthorised work may limit or void the warranty.

FOLDING BICYCLES

Designed for easy storage. May require special instruction before use. Ensure that all locking devices are correctly secured before riding a Folding bicycle.

WHAT IS IT CALLED?

Although bicycle components vary in design, weight and method of use, basically all bicycles are the same.

A bicycle is made up of a frame, wheels, drive train, brakes, stem, handle bars and saddle. Frames must show a makers ID label.

Familiarise yourself with the bicycle's terminology; it will make basic maintenance instructions much easier to follow.

TYPICAL PARTS OF A BICYCLE

NOTE: Not all components nor all bicycle types are shown.

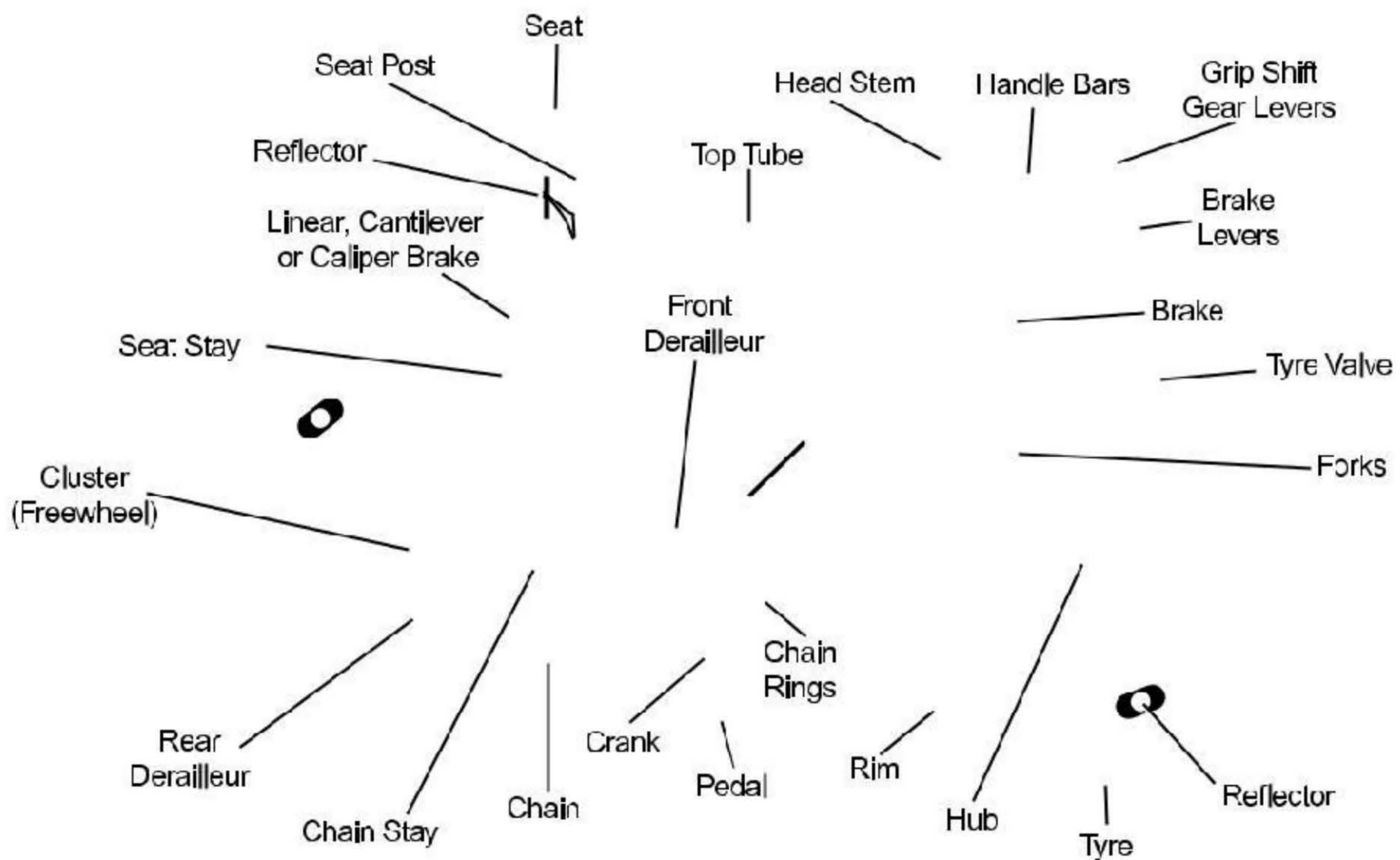

WARNING: Handlebar handgrips or tube-end plugs should be replaced if damaged. Unprotected tube-ends can cause injury. Bicycles used by children should especially be checked to ensure bar end handgrips are in good condition.



FOR ALL TYPES

Where a suspension unit, disk and / or hydraulic brake units, multi-gear hub, electric gear changing system, etc, are fitted, consult manufacturers specification and warranty documents. For correct selection and repair advice, ask your bicycle retailer. Unauthorised work may limit or void a product warranty.

1. SAFETY PRECAUTIONS**1.1 FITTING YOUR BICYCLE FOR A SAFE RIDE**

To ride safely and comfortably a bicycle and its equipment must be matched properly to the size and skills of the rider.

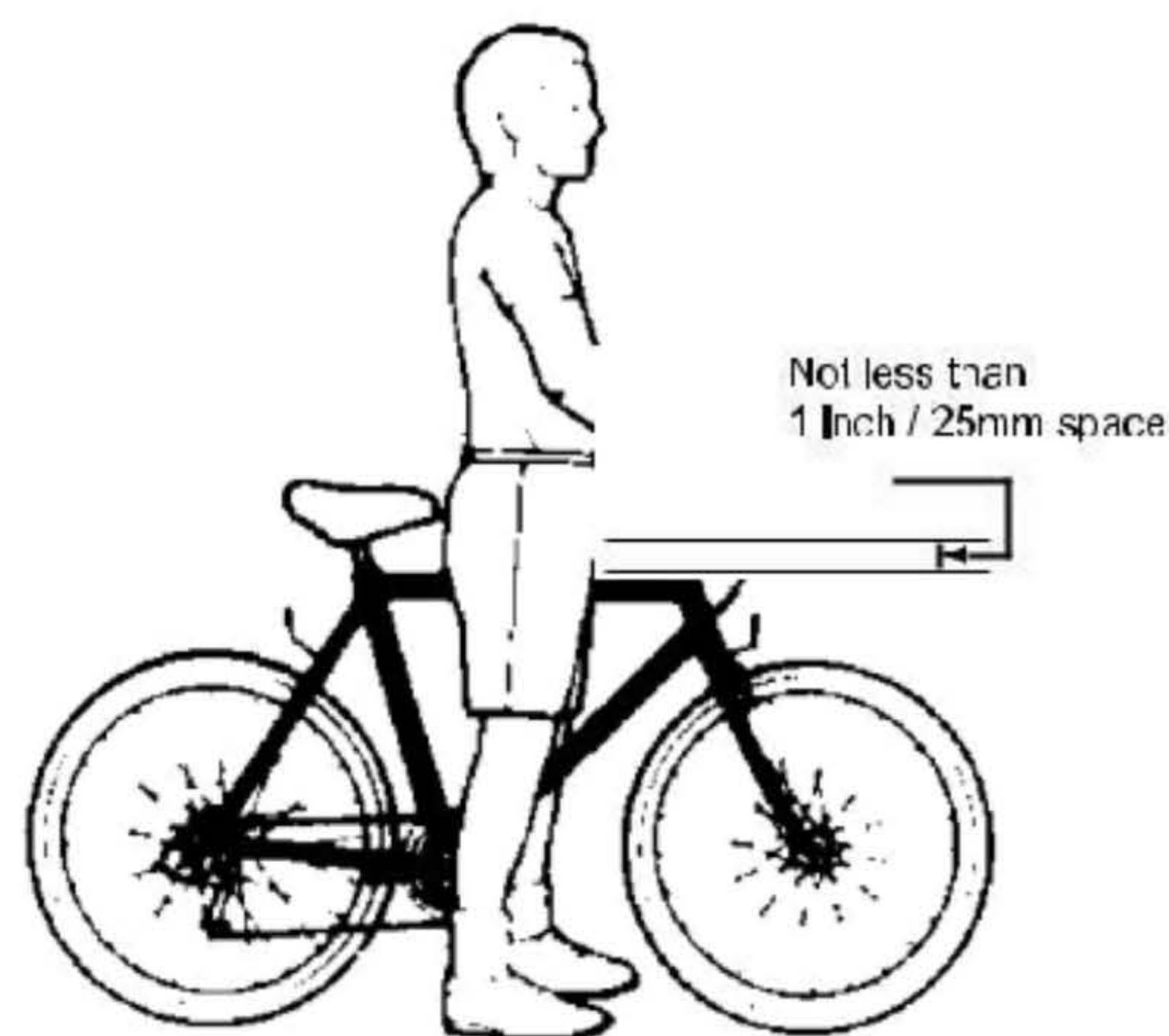
FITTING FOR LEG LENGTH

FRAME SIZE	RIDER LEG LENGTH
14.5"	25 - 26"
15"	26 - 27"
16"	27 - 28"
17"	28 - 30"
18"	29 - 31"
19"	30 - 32"
20"	31 - 33"
21"	32 - 34"
22"	33 - 35"
23"	34 - 36"
24"	35 - 37"
25"	36 - 38"

MAKE SURE THE BICYCLE FITS

A bicycle that is too big or too small for the rider is hard to control and can be uncomfortable. If your bicycle does not fit properly, you may lose control and fall.

SADDLE HEIGHT

To ride comfortably and pedal efficiently, it's very important to have the saddle at the correct height. Your leg length determines the correct saddle height. The saddle is at the correct height for you when, while seated on the saddle, your knee is slightly bent when the crank is at the maximum down stroke (pedal is closest to the ground).

To adjust the saddle height, loosen the seat binder bolt (A) or the quick release (B) and move the seat post up or down as required. Make sure that the saddle is parallel to the top tube of the bicycle. Retighten the seat post tight enough so that you cannot twist the saddle out of alignment.

A loose seat post will allow the saddle to turn or slip and may cause you to lose control and fall. Therefore:

1. Ask your bicycle retailer to help you make sure you know how to correctly clamp your seat post.
2. Before you ride the bicycle, first check that the seat post is securely clamped.

Under no circumstances should the seat post project from the frame beyond its 'Minimum Insertion' or 'Maximum Extension' mark.

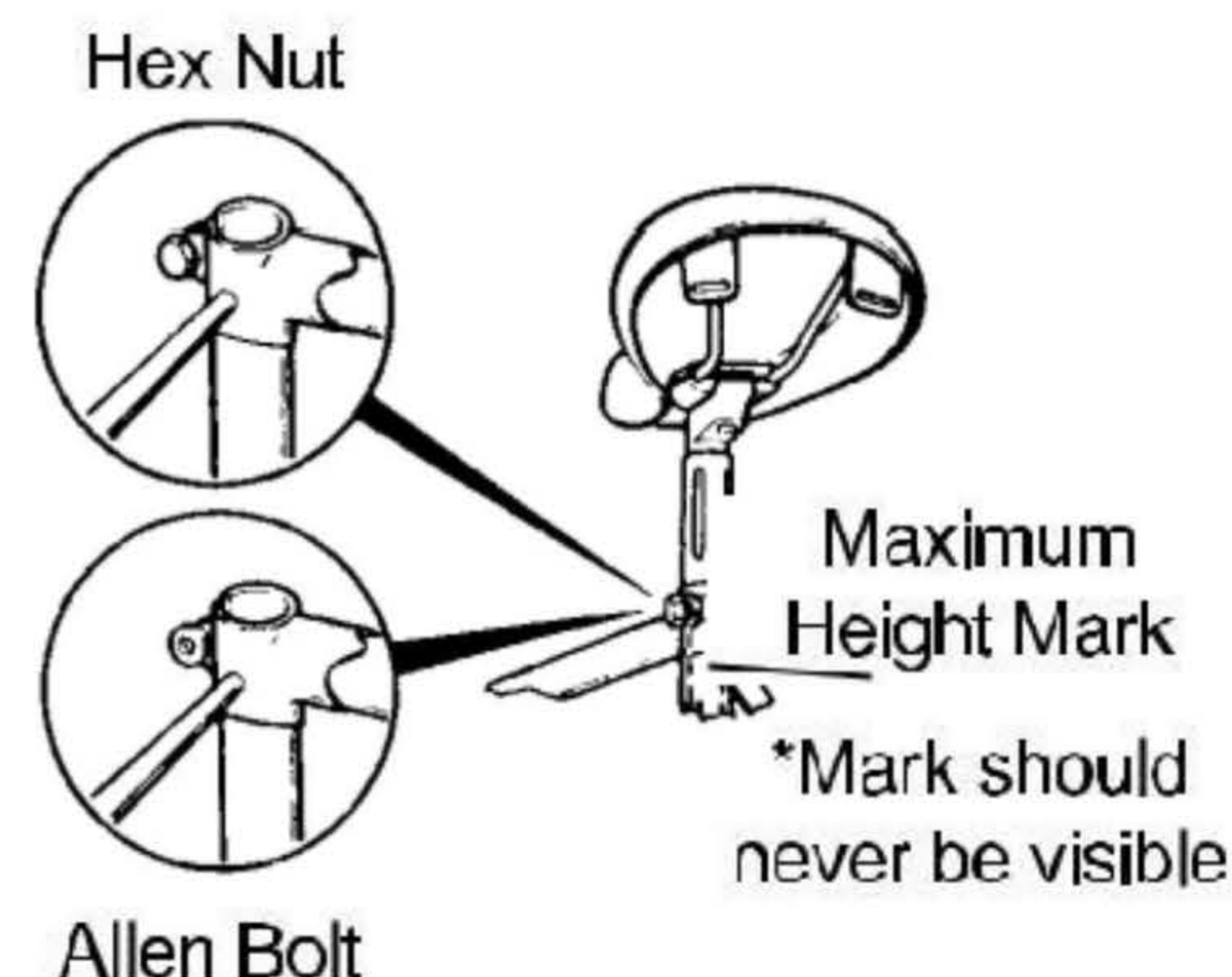
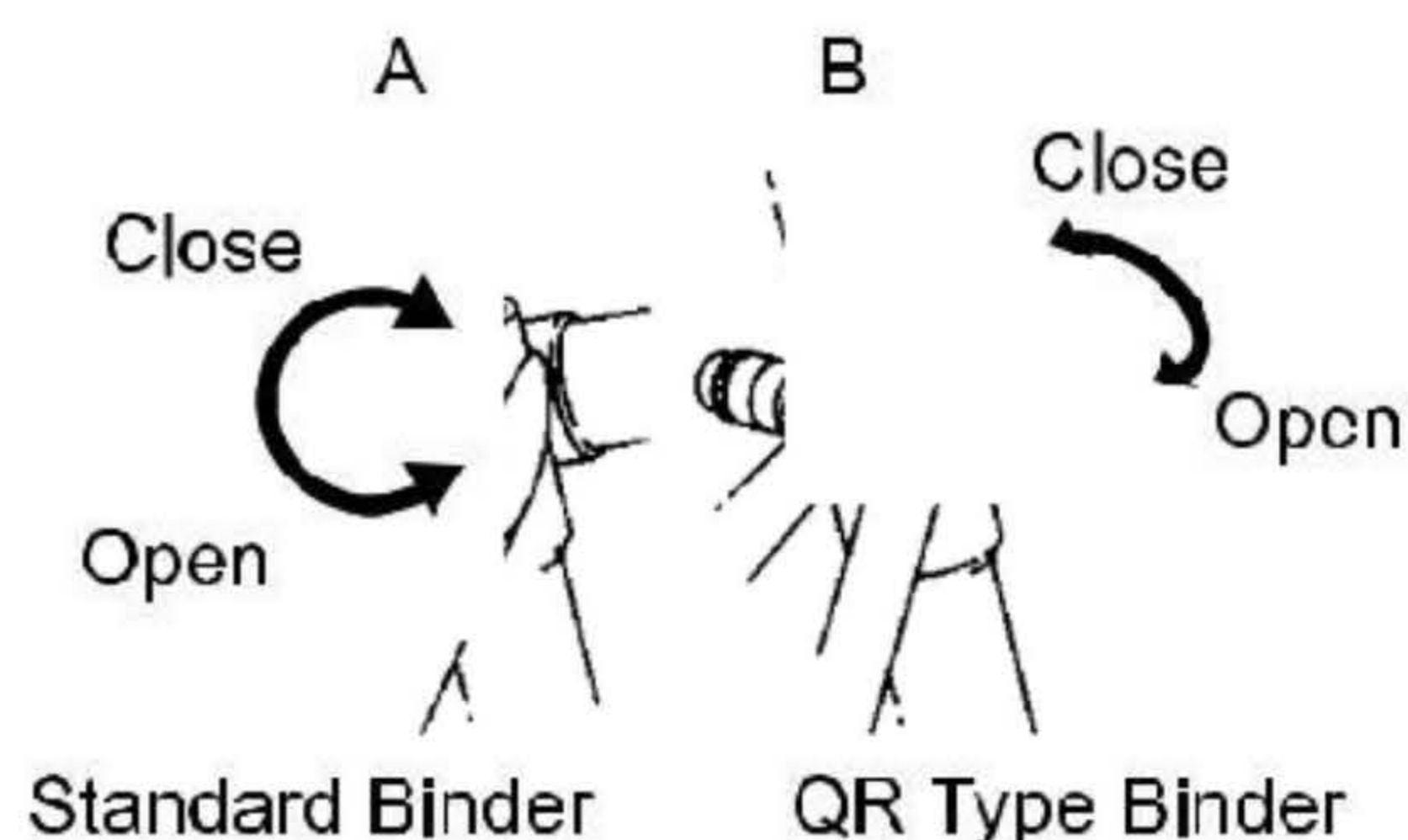

WARNING: do not replace the seat post with a post which is: A) not of the same diameter or B) longer than the original. Either will void the warranty and could lead to seat post failure, loss of rider control and injury.



HANDLEBAR HEIGHT AND ANGLE

After you have set the saddle height and tilt, adjust the handlebar for a safe and comfortable ride.

Ask your bicycle retailer for advice.



WARNING: Under no circumstances should the head stem be retightened with its 'Minimum Insertion' or 'Maximum Extension' mark visible.

'Threadless' headset. DO NOT over tighten the two securing bolts. If unsure, consult your bicycle retailers.

USA & EU (excluding UK & South America)

Front Brake Lever Rear Brake Lever

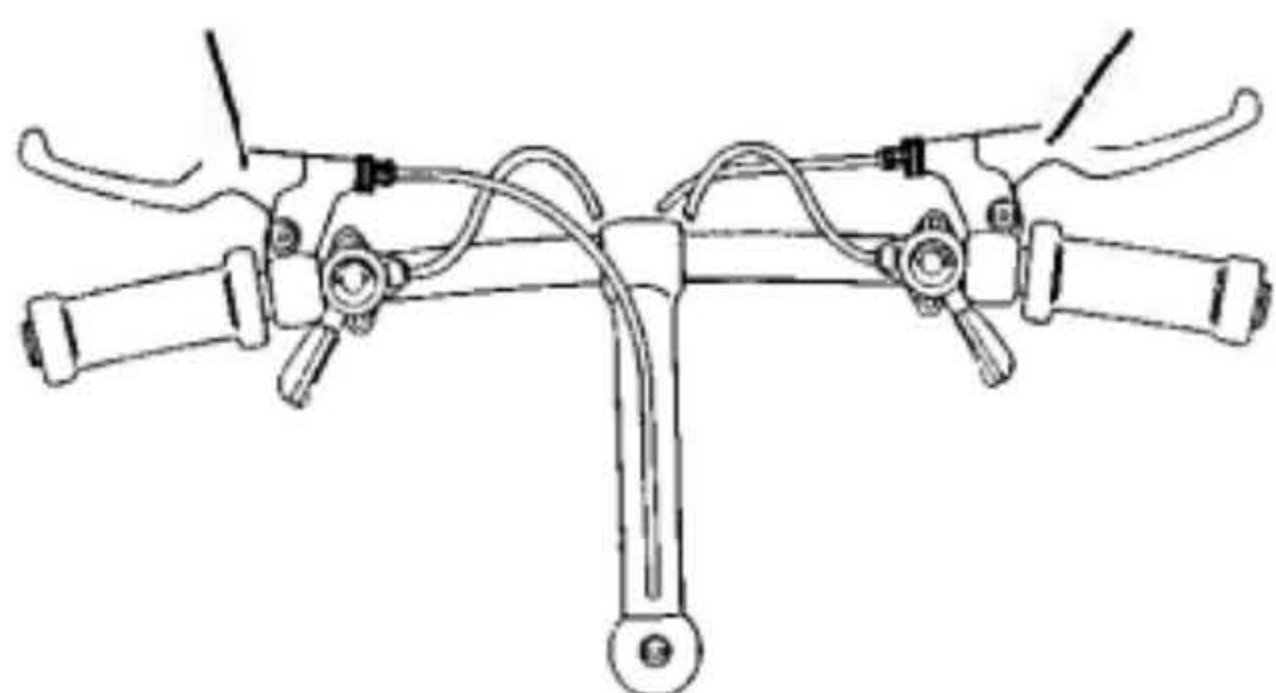

If the front brake cable is attached to the handlebar stem moving the stem up or down will require a readjustment of the brake. If in doubt, ask your bicycle retailer to make the adjustment.

Australia, NZ, UK & South American Riders

Rear Brake Lever Front Brake Lever

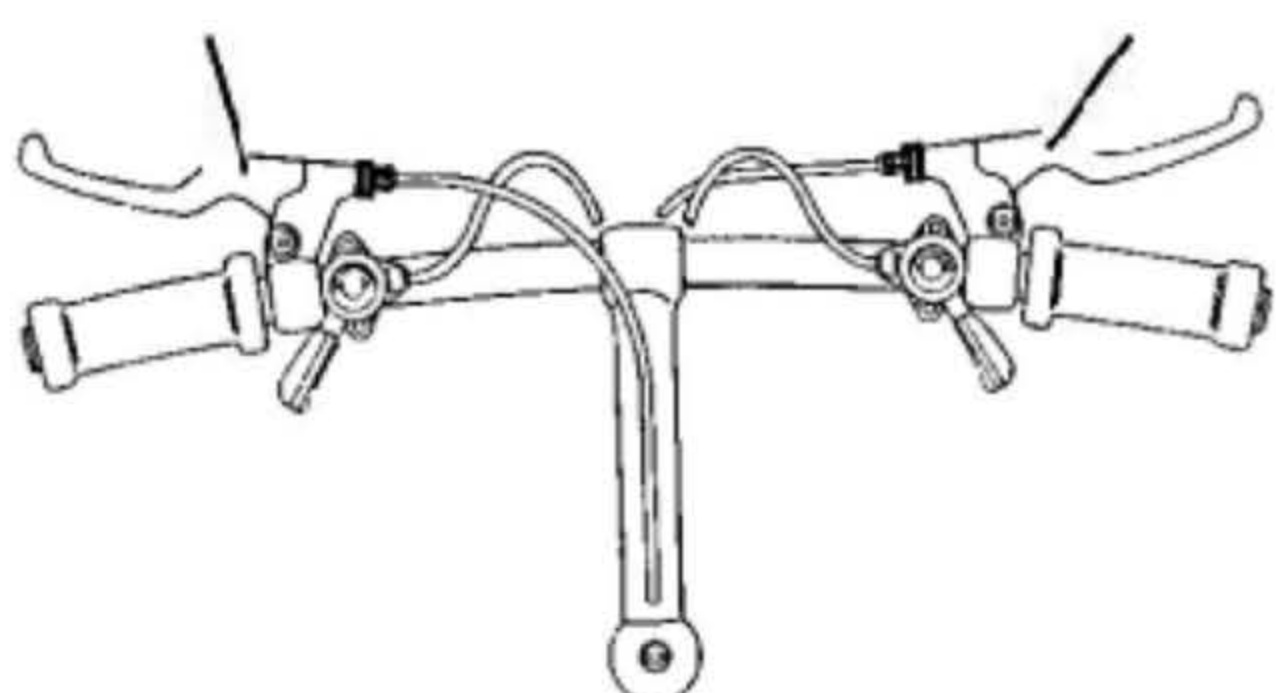

CONTROLS POSITION ADJUSTMENT

The brake and shifting controls on your bicycle are positioned where they work best for most riders. The angle of the controls and the position on the handlebars can be changed. Ask your bicycle retailer to make the adjustments for you.



WARNING: Australia, NZ, UK and South America - front wheel brake lever must be mounted on the right hand side; rear brake lever on the left hand side. USA and EU (excluding UK and South America) - front wheel brake lever must be mounted on the left hand side; rear brake lever on the right hand side.

HAND BRAKE LEVER 'REACH'

Many bicycles have brake levers which can be adjusted for 'reach'. If you have small hands and find it difficult to squeeze the brake levers, your bicycle retailer can either adjust the reach or fit shorter reach brake levers.

1.2 SAFETY CHECK BEFORE RIDING YOUR BICYCLE

c Check and tighten any loose nuts, bolts and straps. If you're not sure, ask your bicycle retailer to check.

c Tyres correctly inflated? Check by pushing down with your thumb on the top of the tyre. The tyre should depress slightly. Compare to how it feels when you know the tyres are correctly inflated.

Replace damaged tyres before they puncture.

c Wheels true? Spin each wheel and check for brake clearance and side-to-side wobble. If a wheel wobbles or hits the brake pads, take the bicycle to your bicycle retailer.

c Brakes: Check that the brakes operate effectively.

QUICK RELEASES

c Are the front wheel, rear wheel and seat post quick releases properly adjusted and in the locked position? Check all quick release mechanisms are correctly and securely closed.

CHECK LIGHTS AND REFLECTORS

c Working

c Correctly aligned

HANDLEBAR AND SADDLE

c Are the handlebar and saddle system: horizontal? tight enough so they won't twist? handlebars secure, good condition? handle bar ends plugged?

c Is a bell fitted and working?

Any broken or worn parts should be replaced before the bicycle is used.

Certain activities may damage your bicycle and result in serious personal injury. Take these precautions:

- avoid jumping kerbs
- avoid potholes and gratings
- avoid stunt riding and jumping



WARNING: Do not remove protective safety equipment fitted to your bicycle, including handlebar end covers or plugs; reflectors fitted to frame, wheels and pedals; reflector mount brackets (where cantilever brakes are fitted); front chain ring guard; rear wheel spoke protector (right hand side); chain guard where fitted; warning stickers affixed to frame.



Note: A replacement fork must be the same length and maintain the same rake and trail characteristics as the original. Ask your bicycle retailer for advice.

1.3 SAFETY EQUIPMENT AND SENSIBLE RIDING

As a road user you have responsibility for your own safety and the safety of others.

You need to know:

- the road rules
- how to ride safely

YOUR BICYCLE

- Check your bicycle before you use it. (Use the safety check 1.2 including the adjustments).

YOUR BICYCLE (CONT)

- Know how to work all bicycle controls.
- For riding in low light and night conditions, fit your bicycle with appropriate front and rear lamps.

WARNING: Check reflectors and mounting brackets regularly to make sure that they are clean, straight, unbroken and securely mounted. Equip your bicycle with lights: **white front** and **red rear**. Riding in low light or at night time without reflectors and lights is extremely dangerous.

The mounting position for reflectors shall be above the level of the back axle, and shall be such that the reflector(s) are not obscured from view eg. By the riders clothing or by the wheel.



YOUR CLOTHING

- Wear a correctly fitted and fastened Approved helmet.
- Be seen:
wear brightly coloured clothes - yellow, green and orange are best for day, reflective tape improves the conspicuity of riders at night.
- Wear shoes, not thongs or ride with bare feet.

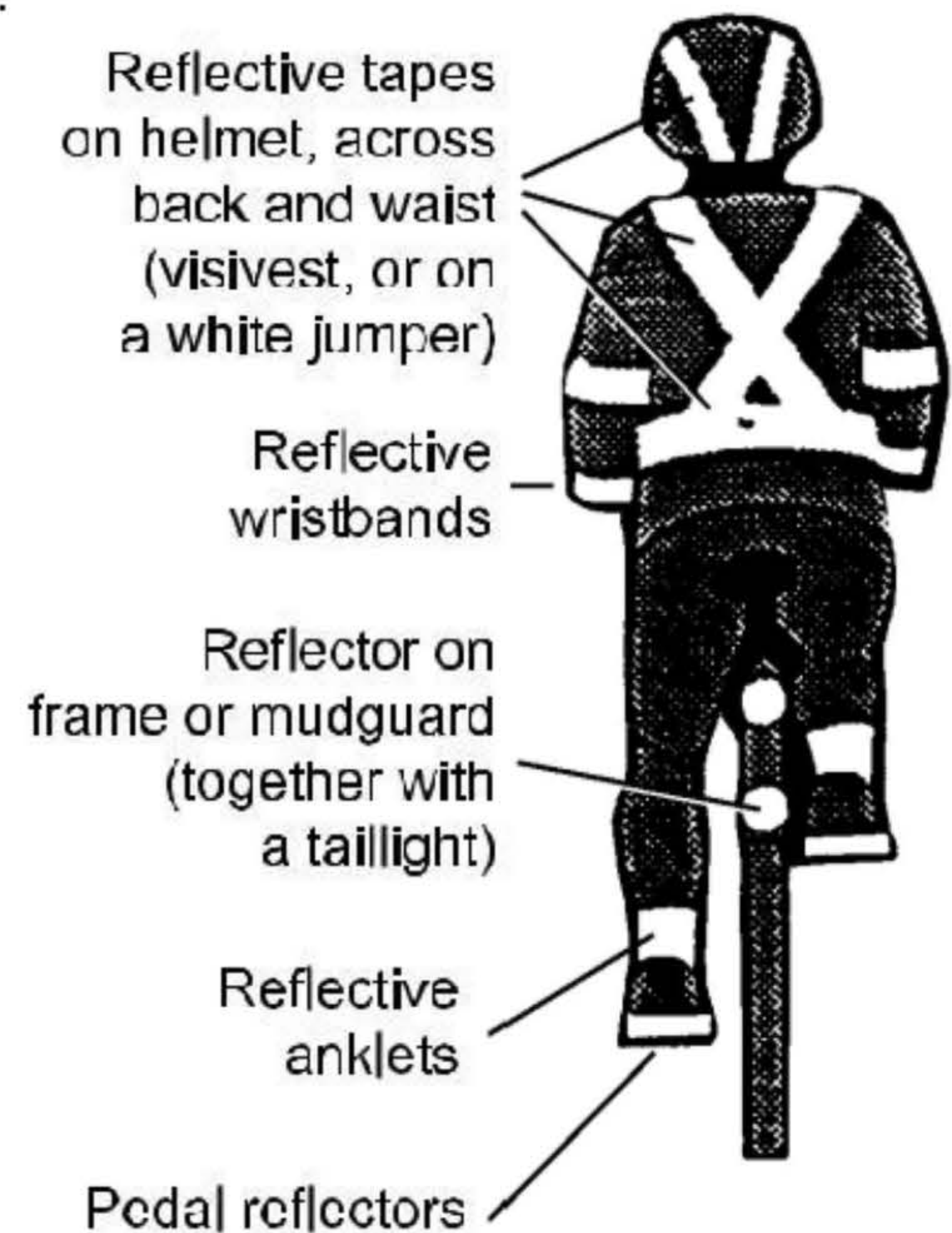



WARNING: Always wear a correctly fitted and fastened helmet when riding your bicycle.

Correct Fit



Incorrect Fit



BE ALERT

- Obey all road rules
- Watch out for other road and pathway users.
- Adapt your riding to suit the conditions.

CARRYING LOADS

- Use correctly fitted carriers, racks, panniers or a back pack for parcels.

RIDING IN THE WET

Wet weather affects visibility for all road users.

It is harder for you, and other vehicles, to stop in the wet. Allow more distance to brake.

RIDING IN LOW LIGHT

Riding when light levels are low: - use lamps and reflectors, - wear bright reflective clothing.

BE RESPONSIBLE

Follow the road rules. Use common sense. If riding in remote areas:

- go with a friend
- leave details of route and return time with a responsible person
- tell them when you get back!

PARENTS

Most cycling incidents involve small children and teenagers.

Make sure:

- The bicycle is in good working order
- The rider knows: How to use the controls
 The road rules
- Clothing, helmet, lighting are appropriate for the bicycle trips undertaken.

QUICK SAFETY SUMMARY

- Obey all traffic laws
- Be predictable
- Be alert
- Use reliable safety equipment
- Use the bicycle for the manufacturer's recommended purpose
- Adjust riding to traffic and weather conditions
- Wear appropriate clothing
- Follow the manufacturer's instructions for any adjustments

2. HOW THINGS WORK

It's important for your enjoyment and safety to know how things work on your bicycle.

QUICK RELEASE (QR) MECHANISM

The bicycle quick release allows wheel removal without the need for tools.



WARNING: Riding with an improperly adjusted wheel quick release can allow the wheel to wobble or disengage from the bicycle, causing damage to the bicycle and risk of a crash.

It is essential that you:

- Ask your bicycle retailer to show you how to install and remove your wheels safely.
- Use the correct technique for clamping your wheel in place with a quick release.
- Before you ride the bicycle, check that each wheel is securely clamped.

The Wheel Quick Release is a long bolt called a skewer, with a lever on one end and a nut on the other, the wheel quick release uses a cam action to clamp a bicycle wheel in place.

ADJUSTING THE QUICK RELEASE MECHANISM

The wheel hub is clamped in place by the force of the Quick Release lever cam pushing against one dropout and pulling the adjusting nut using the skewer against the other dropout.

Turning the adjusting nut **CLOCKWISE** will **INCREASE** the clamping strength of the lever.

Turning the adjusting nut **ANTI-CLOCKWISE** will **DECREASE** the clamping strength of the lever.

The full force of the cam action is needed to clamp the wheel securely. You cannot secure the quick release mechanism by twisting the adjusting nut. Never use the QR lever to wind up the mechanism. Tighten or loosen using the adjusting nut with the QR lever in the open position.

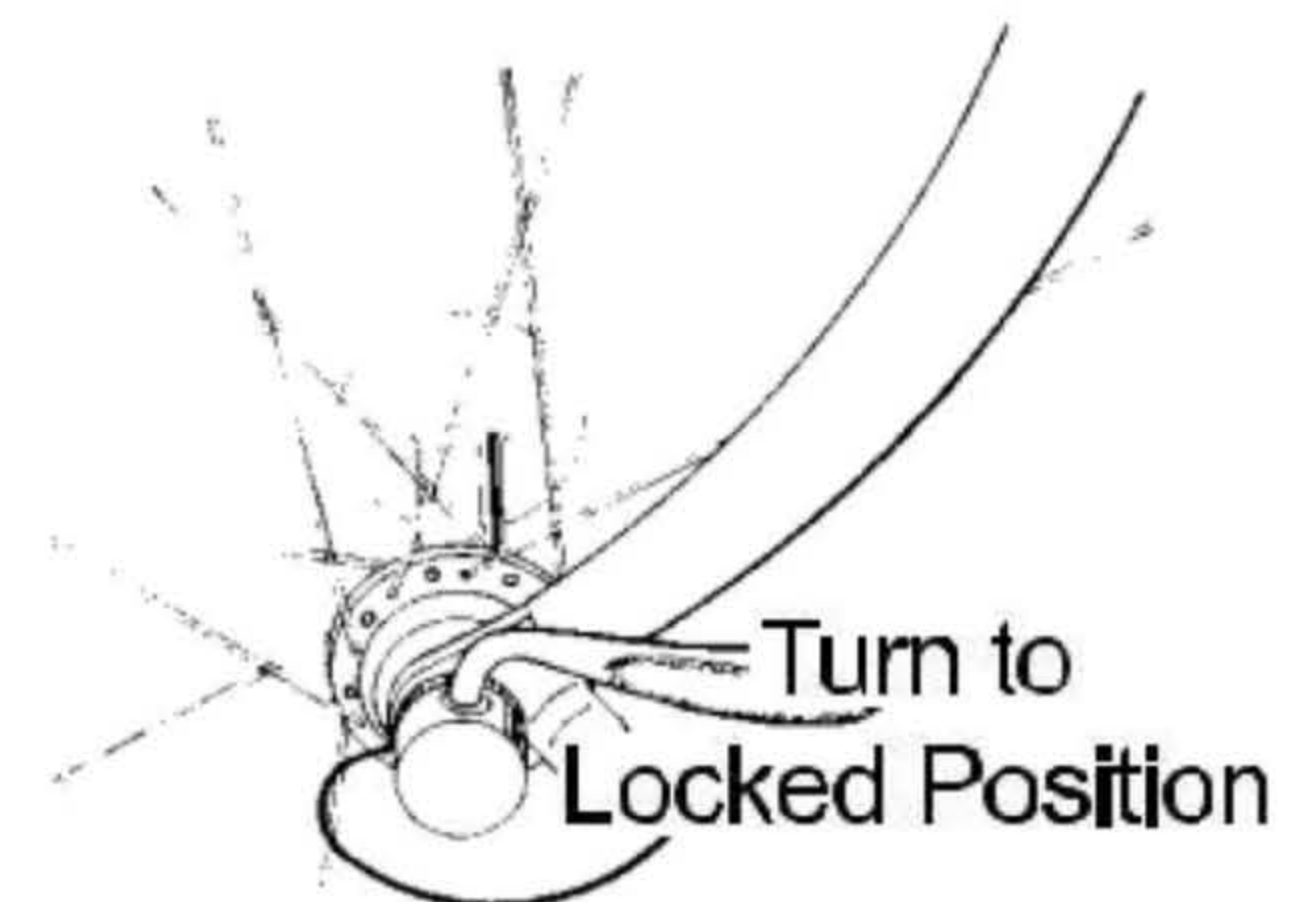
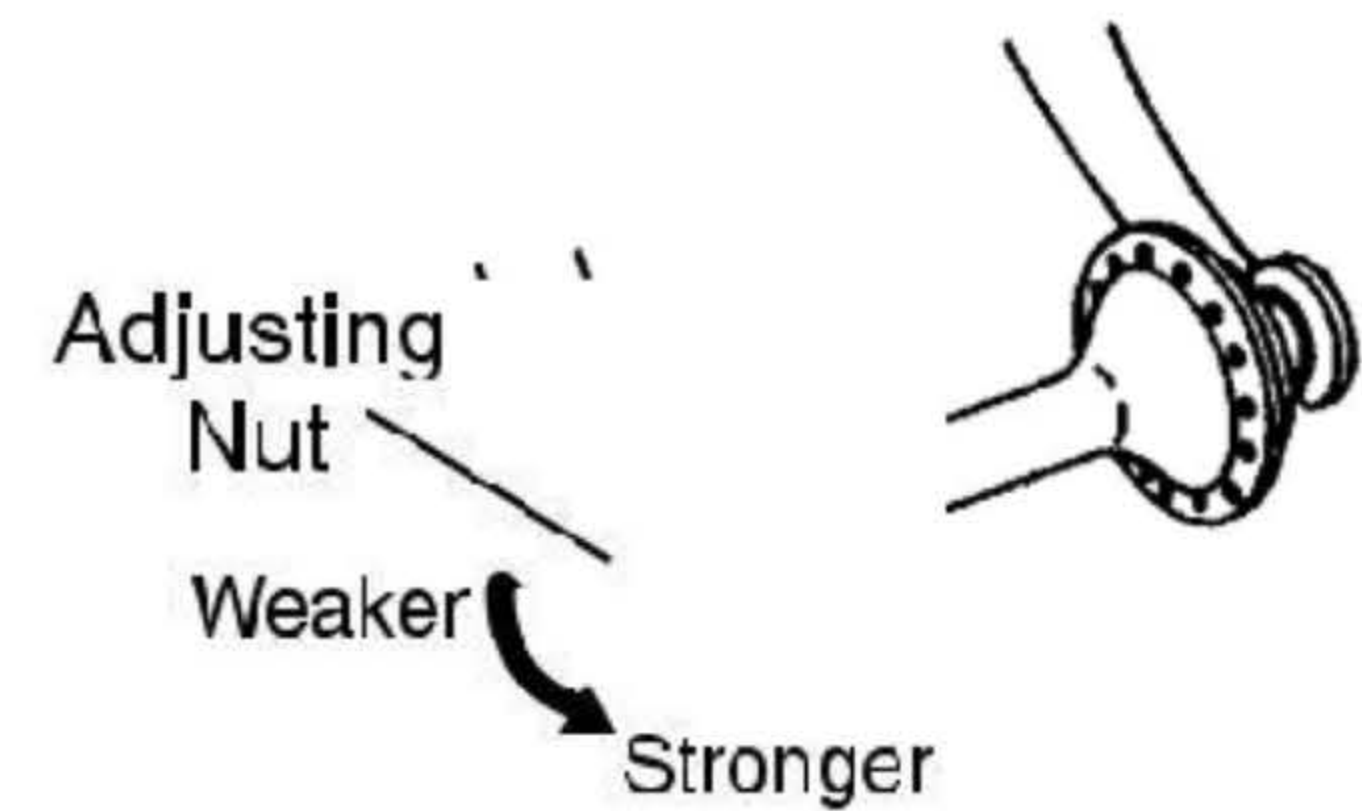
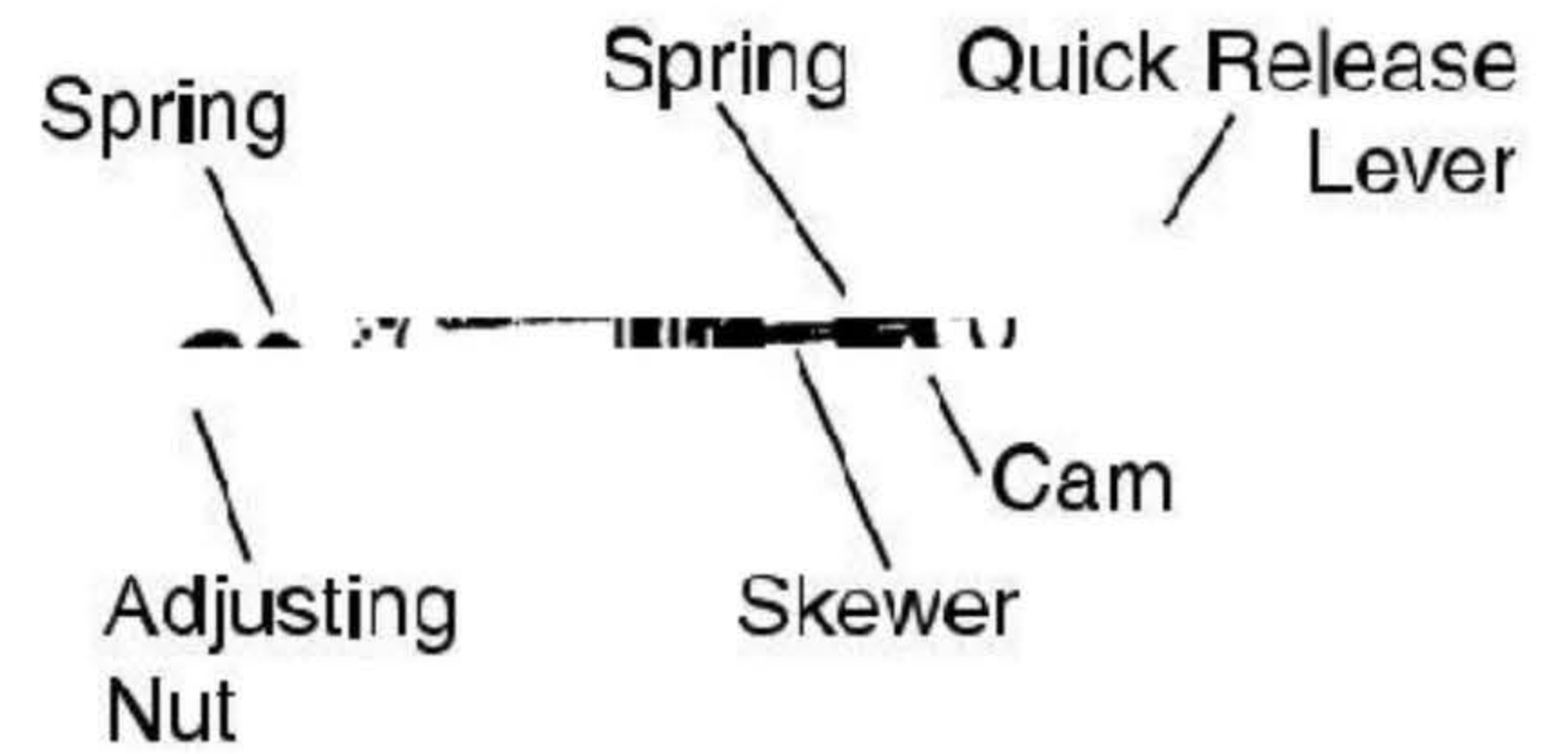

FRONT WHEEL SECONDARY RETENTION DEVICES

Some bicycles have front forks which use a secondary wheel retention device to keep the wheel from disengaging if the axle nuts loosen.

Some bicycle front forks have a shaped lug which acts to keep the wheel from disengaging if the axle nuts are loosened. To remove the wheel the axles nuts (or quick release mechanism) must be backed off far enough for the wheel to be removed.

WARNING: Removing or disabling the secondary retention device is extremely dangerous, may void the warranty, and can lead to serious injury.



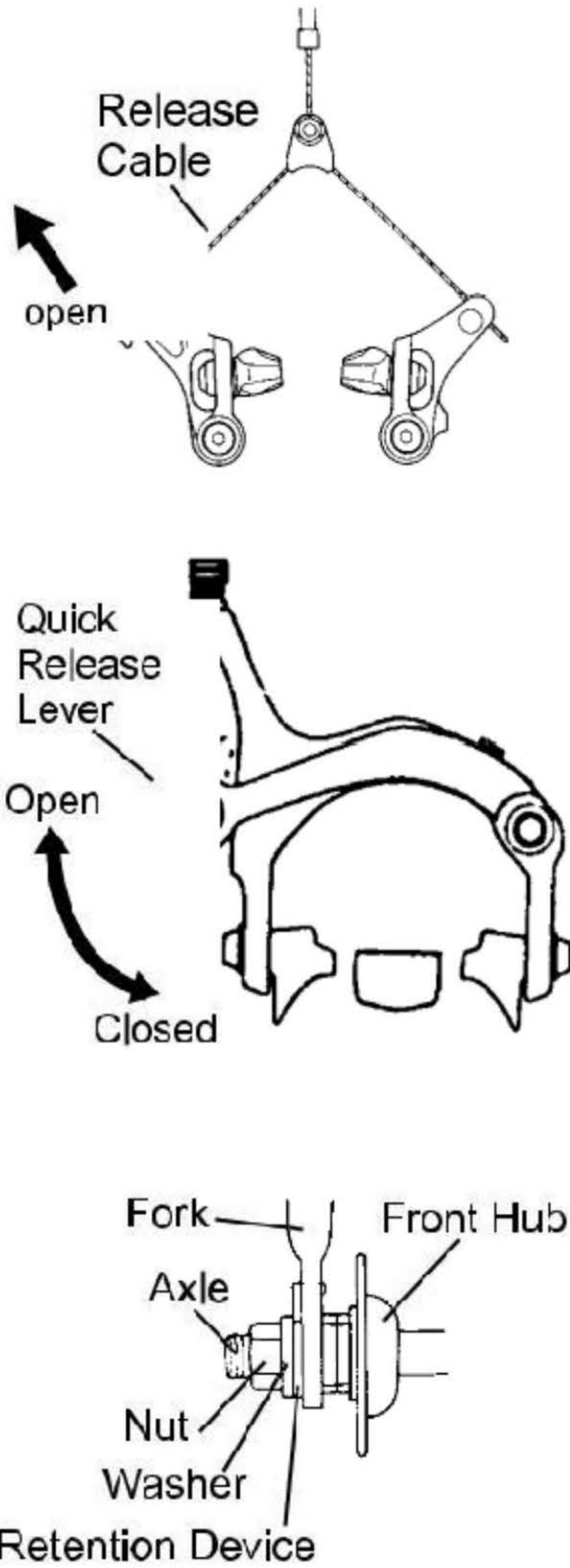

REMOVING THE FRONT WHEEL

Cantilever and Linear brakes

Release the Brake Quick Release. (This will allow the brakes to be opened to let the tyre pass between the brake blocks).

Side pull brakes

Release the Brake Quick Release. (This will allow the brakes to be opened to let the tyre pass between the brake blocks).

Move the Wheel Quick Release Lever to the open position.

If your bicycle is fitted with secondary retention devices unwind the Quick Release Lever enough to allow the wheel to be removed.

If your front wheel is fitted with axle nuts instead of a Quick Release mechanism, use a spanner of the correct size to fit the axle nuts.

- Unwind the axle nut sufficiently to allow the secondary retention devices to release.
- Hold the front of the bicycle 30mm to 50mm off the ground to allow the wheel to be removed.

INSTALLATION OF THE FRONT WHEEL

The installation is the reverse procedure to Removing the Front Wheel, except:

- Make sure the wheel axle is correctly positioned in the fork (see diagram).
- Position the Quick Release parallel to the front fork when it is in the CLOSE position. This will prevent the lever being knocked open whilst riding.
- The Quick Release Lever is positioned on the left hand side.

Axle correctly seated in dropout

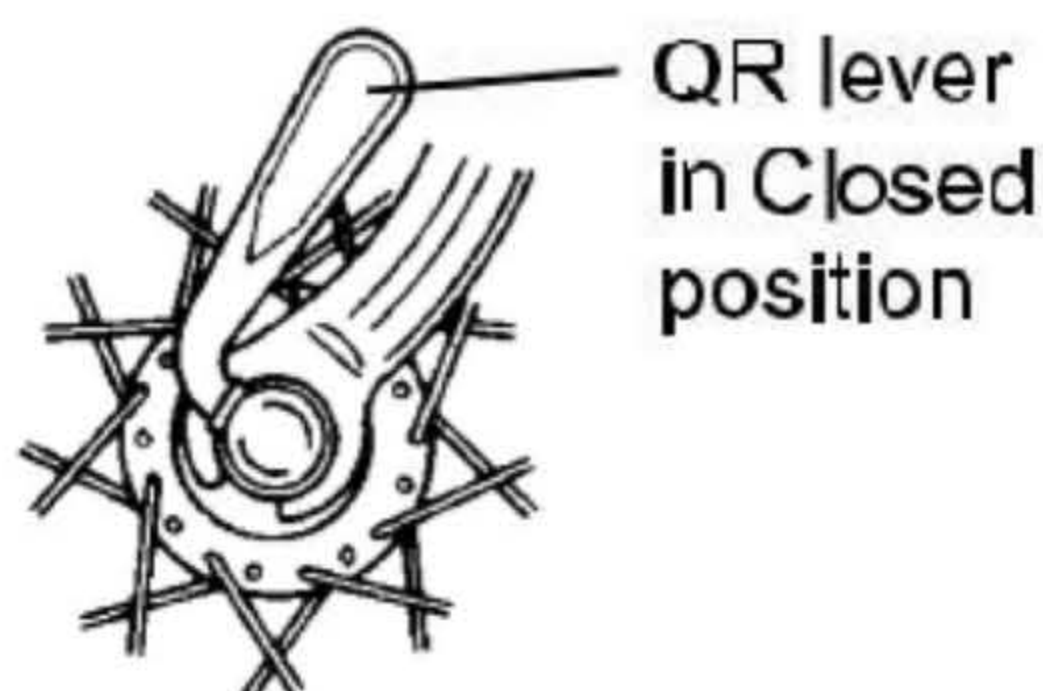

ADJUSTMENT NOTES

If the Quick Release Lever can be easily pushed to the CLOSE position, the clamping strength is insufficient.

- Return the lever to a position at right angles to the fork.
- Turn the Adjusting Nut clockwise to increase the clamping strength.
- Push the lever back to the CLOSE position to check the clamping strength.
- You will need a reasonable amount of force to CLOSE the lever to ensure the adjustment is correct.

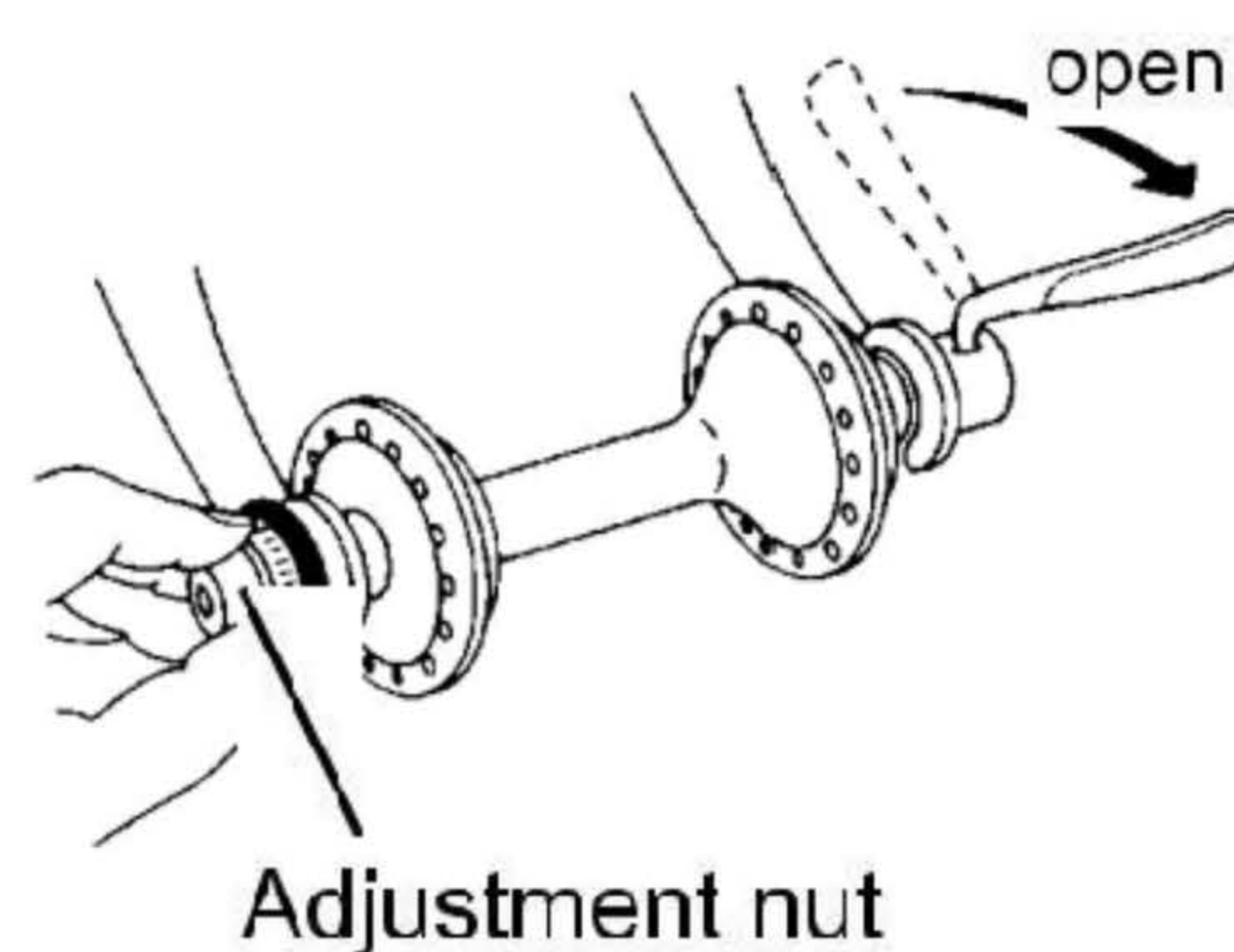

NOTE: If you are not sure of any of these steps or how the quick release mechanism operates ask your bicycle retailer.



REMOVING THE REAR WHEEL

- Set the rear gear lever so that the chain can be moved to the smallest cog.
- Release the Brake Quick Release (see Removing the Front Wheel)
- If fitted with axle nuts, use the correct spanner to loosen the axle nuts enough to allow the wheel to be removed.
- If fitted with a Quick Release Lever, move the lever into the OPEN position. This allows the wheel to be removed.
- Lift the bike off the ground 30-50mm, push the wheel forward and down until it comes out of the dropouts.

QR lever
in Closed
position

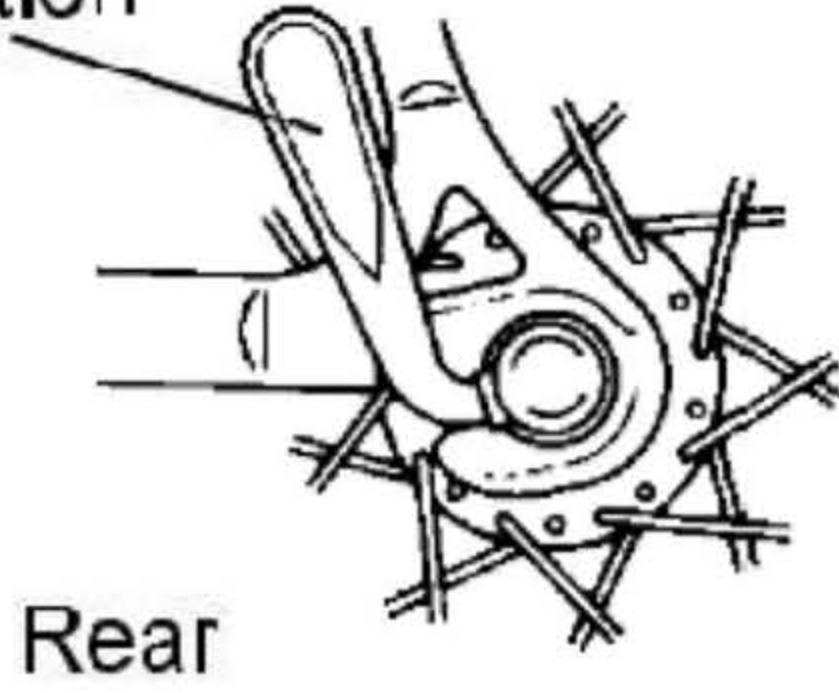

INSTALLING THE REAR WHEEL

Installation is the reverse procedure of removing the rear wheel. NOTE: Make sure that the chain is on the small cog as you position the rear wheel in the dropouts.

Check that you have the correct clamping pressure (Quick Release Lever).

If you have axle nuts make sure they are tightened correctly.

Ensure that the Quick Release Lever is positioned as shown to prevent the lever from releasing whilst riding.

When repositioning the wheel in the frame make sure that it is centrally located to prevent 'rubbing' of the wheel on the frame.



WARNING: Failure to properly reinstall a wheel may result in a crash.

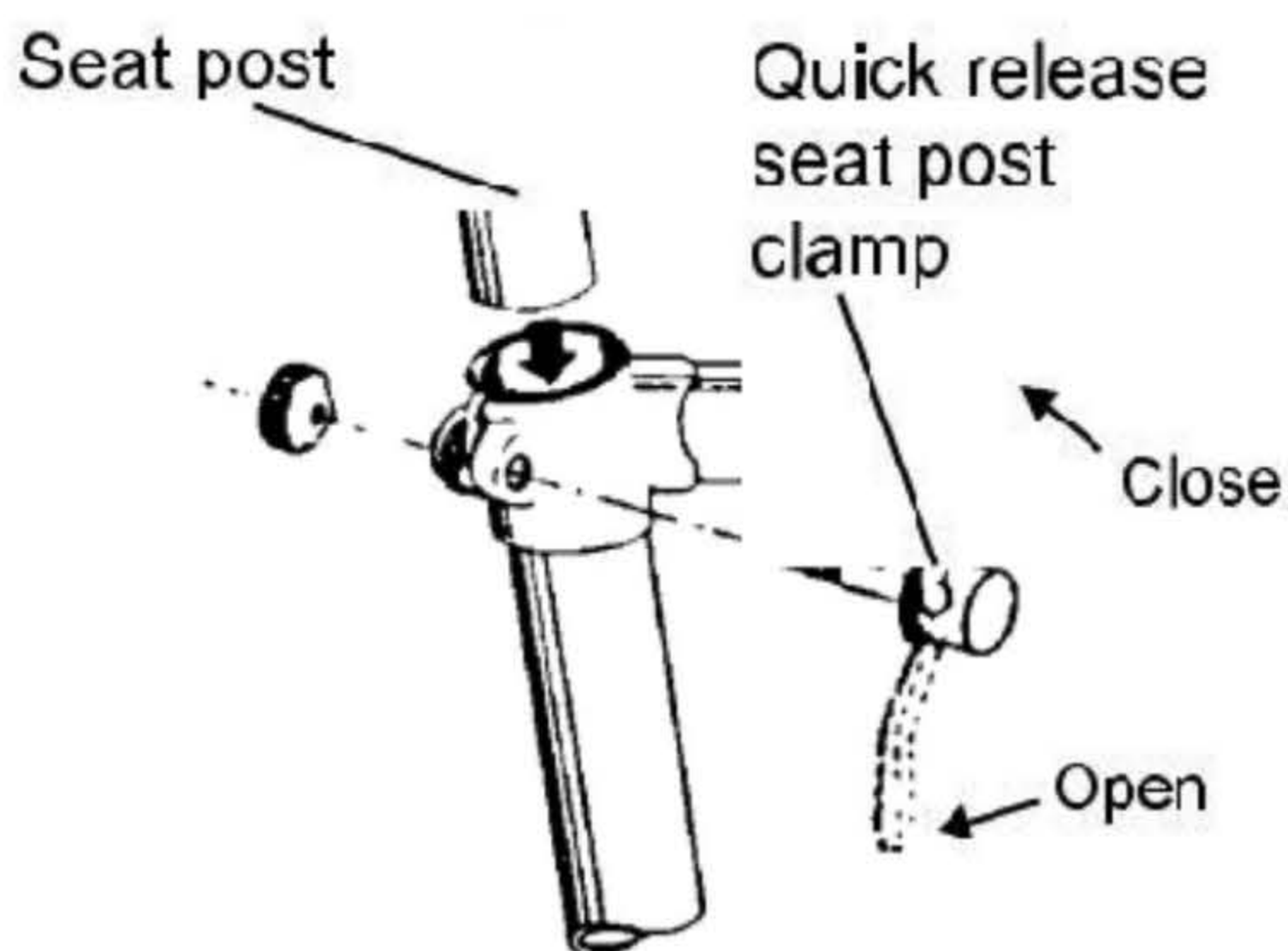

SEAT POST QUICK RELEASE

Many bicycles are equipped with quick release seat post clamps. The seat post quick release clamps work exactly like the Wheel Quick Release.

See Adjusting the Quick Release Mechanism.

Follow the steps described to adjust the height of your seat post.



WARNING: The full force of the cam action is needed to clamp the seat post securely.

OTHER SEAT POST FIXINGS

- An Allen Key Bolt or a nut is used. You must use the correct type of tool to make adjustments.
- The Seat Post must be inserted in the seat tube to at least the minimum insertion point.
- Ensure indexing lug on the seat post clamp bolt is correctly engaged in the seat tube clamp.

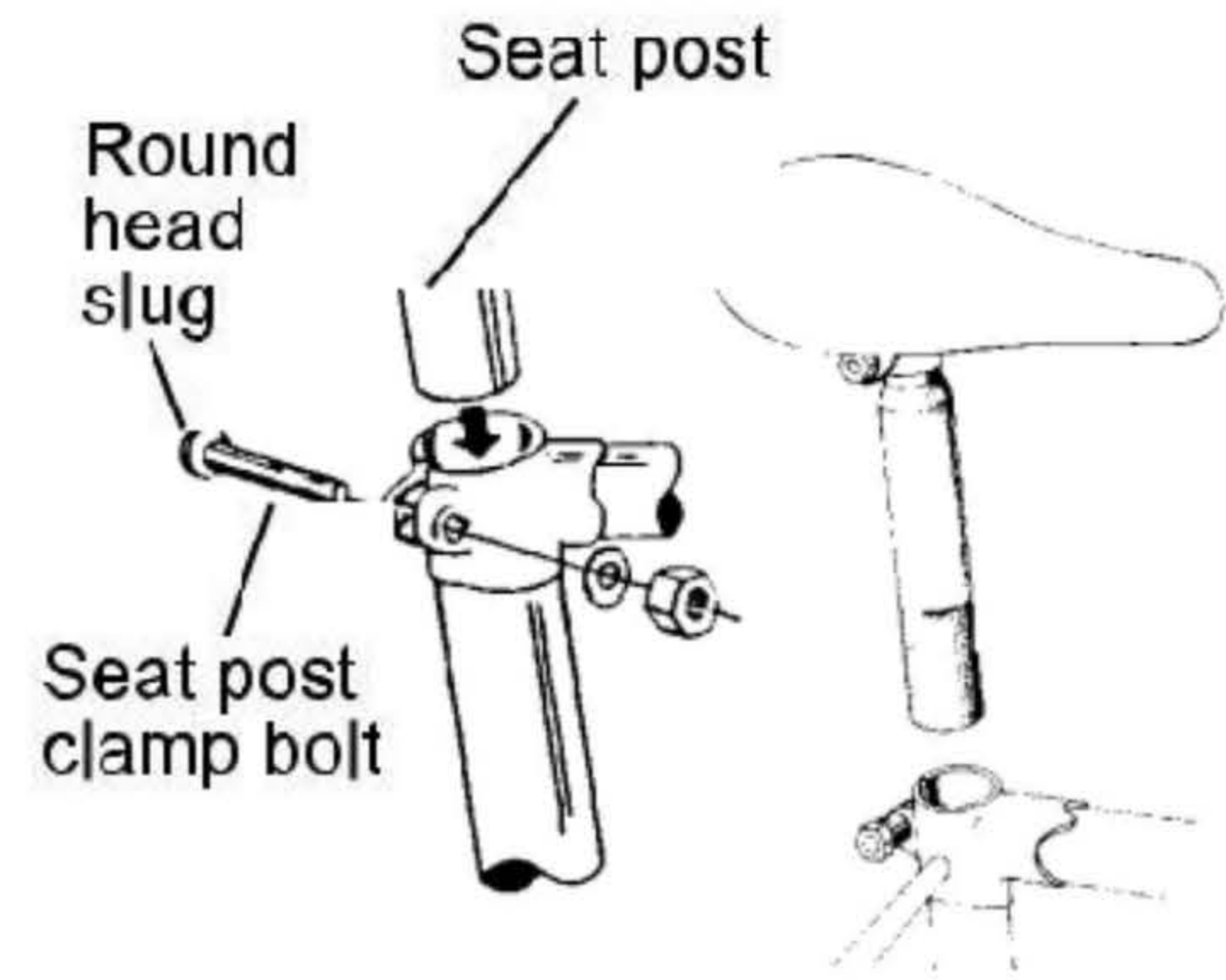

BRAKES

The braking action of a bicycle is a function of friction between brake surfaces, usually the brake blocks and the wheel rims.

- Keep your wheel rims and brake blocks clean and free of lubricants, waxes or polishes.
- Make sure that your hands can reach and squeeze the brake levers comfortably.
- Most bicycles are fitted with front and rear hand brake levers and these are attached to either CANTILEVER CALIPERS, SIDE PULL CALIPERS, DISK or LINEAR BRAKES.
- When replacing both brake cables check that the left hand cable is fitted to the rear brake when looking from the riding position.
- To adjust chain tension on a bicycle fitted with a back pedal brake or internally geared hub with a single freewheel cog, the back wheel must be moved forward or backward in the dropouts. Loosen the axle nuts and brake arm clip. Allow 10 - 12mm of up/down chain movement halfway between chainring (front) and cog (rear). Re-tighten nuts and brake arm clip.
- For back pedal brakes: check that the brake arm clip is securely attached to the chain stay.



Linear

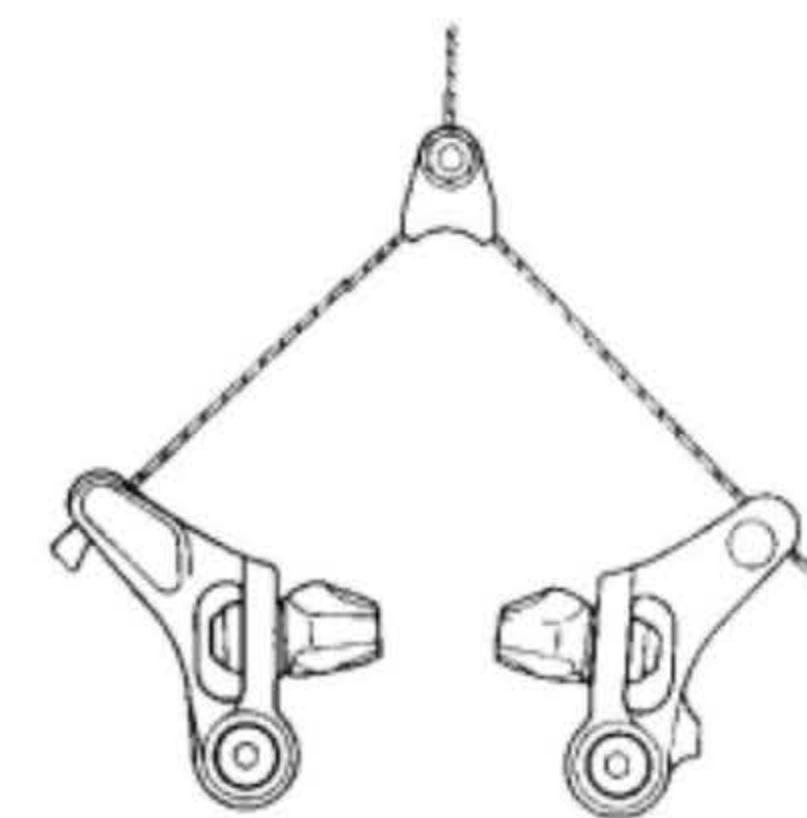

Cantilever

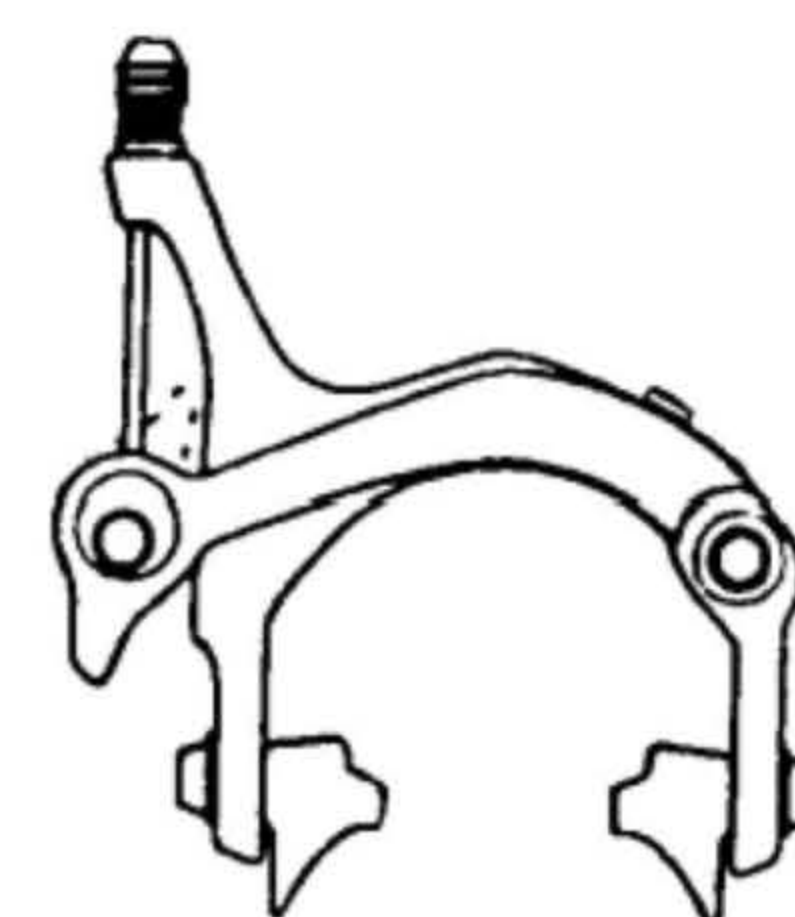

Side Pull Brake

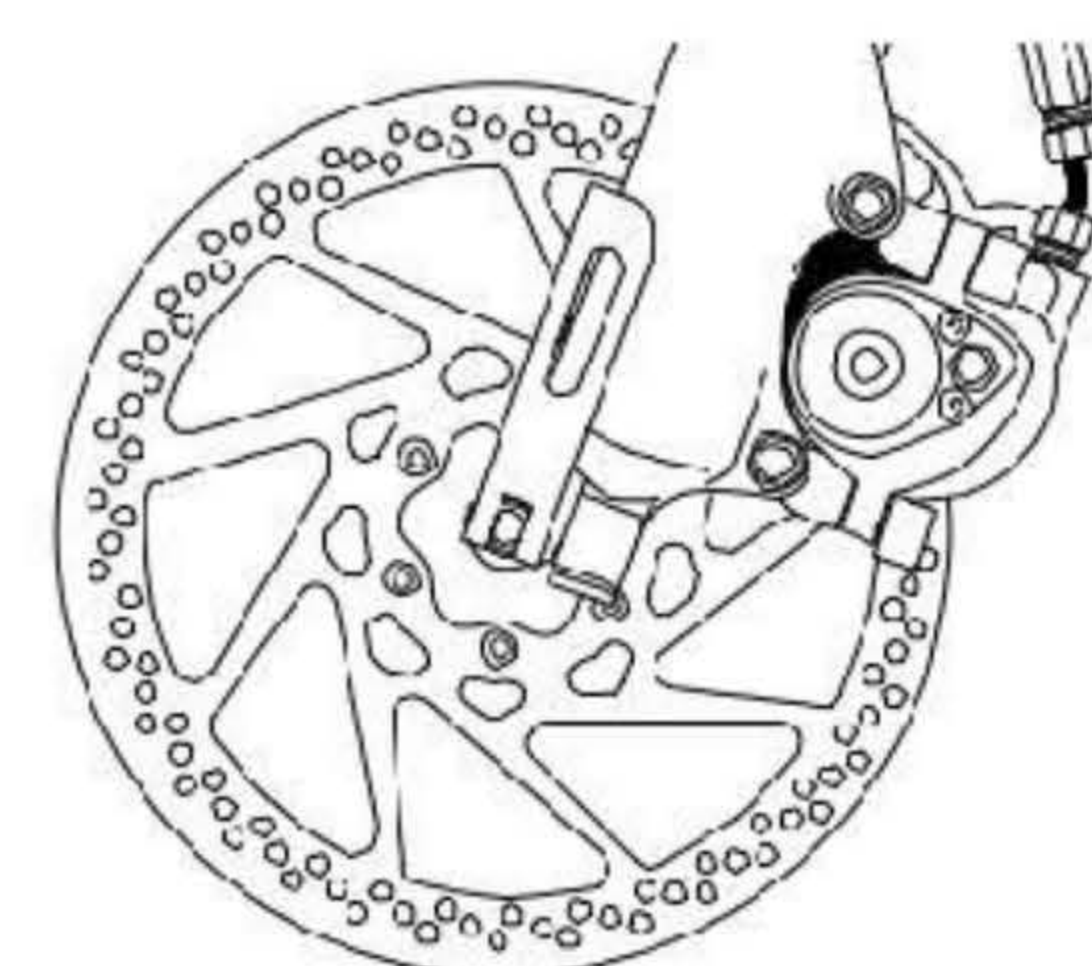

Disk Style Brake System



WARNING: Careless use of the front brake first can cause a crash.

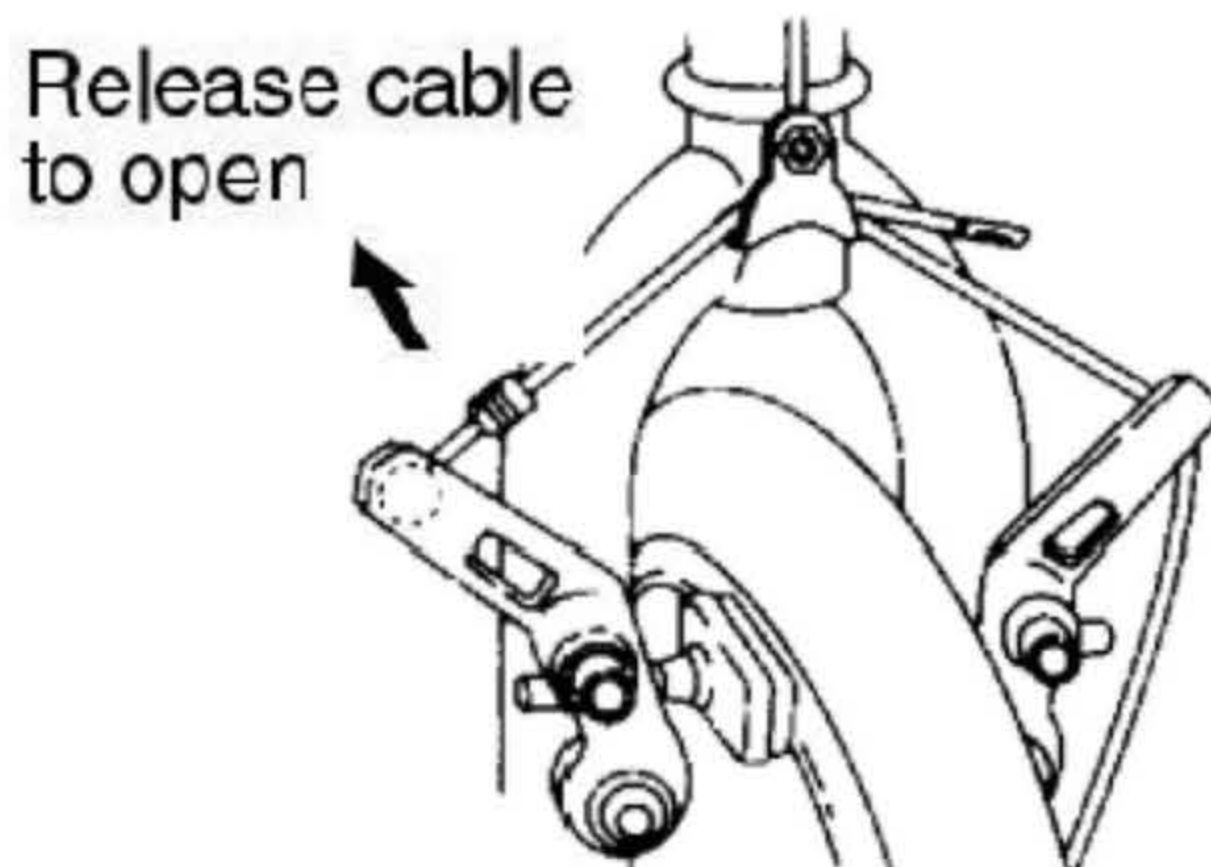

Note: Most brakes have some form of quick release mechanism to allow the brake shoes to clear the tyre when a wheel is removed or reinstalled. When the brake quick release is in the open position, the brake will not operate. Ask your bicycle retailer for help. Make sure you understand the way the brake quick release works on your bicycle.

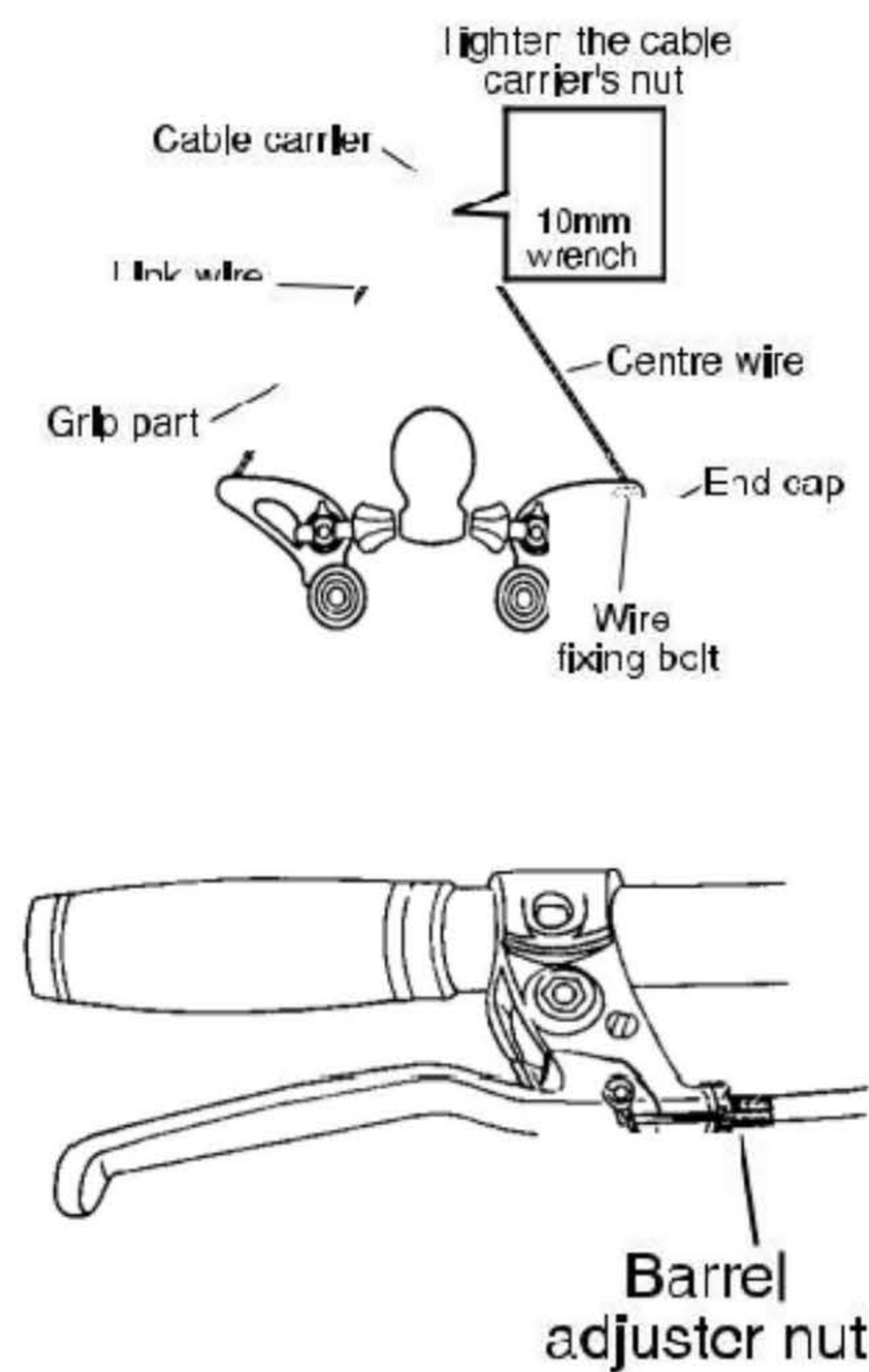

BRAKE ADJUSTMENT

CANTILEVER TYPE BRAKES

- You should have approximately 2mm clearance between the brake blocks and the wheel rim.
- To adjust the brakes, on the brake lever turn the barrel adjuster **CLOCKWISE** to loosen the brake. Move the adjuster **ANTI-CLOCKWISE** to tighten the brake. Turn the lock ring located below the barrel until it stops to set your adjustments.
- If your brakes shudder/squeal you need to check the toe in/out alignment of the brake blocks. The leading edge of the block should be 0.5 - 1mm, closer to the wheel rim than the trailing edge.
- To centre the brake arms, loosen the cable carrier nut, slide the cable carrier up or down until it centres the brake blocks (so there is an even gap on either side of the rim).
- Retighten the cable carrier nut.
- Spin the wheel to ensure the brake blocks, do not rub on the wheel rim.

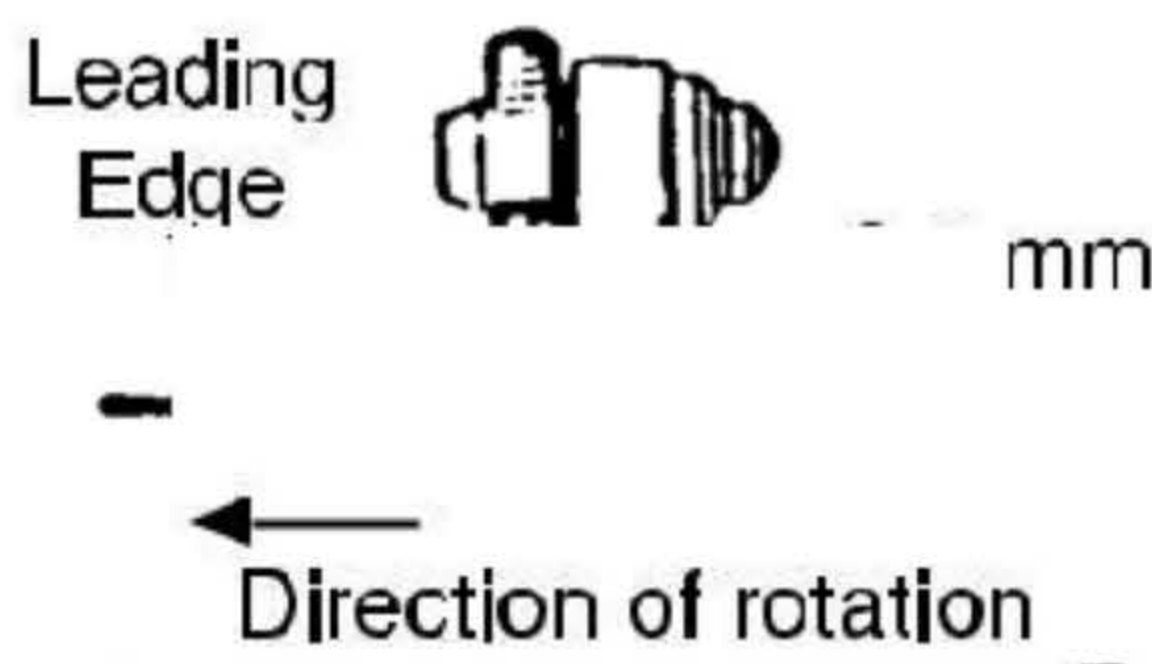

- Use the springforce adjustment screw to change toe in/out position.
- Using an Allen key turn CLOCKWISE to move the brake pad trailing edge out. Turn the Allen key ANTI-CLOCKWISE to move the brake pad trailing edge in.

LINEAR TYPE BRAKES

- A Linear brake arm might have a post type brake block (as for a Cantilever brake) or a block which can only be adjusted for toe-in and block-to-rim alignment, in which case brake block-to-rim clearance is adjusted by changing the brake cable length at the brake arm or at the brake lever cable adjuster. Ask your bicycle retailer how to make the correct adjustment.
- To release a Linear brake press the brake arms together and unclip the cable lead unit (curved metal tube) from the pivotted metal stirrup. The brake cable remains attached to the opposite brake arm. If the cable lead unit and cone shaped ferrule cannot be unclipped either slacken the cable at the brake lever (using the cable adjuster) or release the cable end which is attached to the brake arm.
- NOTE: Allow sufficient 'travel' in the brake lever and cable to enable the curved cable lead tube to be unclipped from the stirrup.
- To reset the cable lead tube press the brake arms together and re-clip into the pivotted metal stirrup.

IMPORTANT: Ensure the cone shaped ferrule is fully seated in the stirrup. Ensure the protective flexible bellows or accordion-like cable protector between the brake arm and the stirrup is correctly located.

LINEAR BRAKE (CONT)

- Brake lever 'travel' can be adjusted for ease of use by a child or anyone with small hands by means of the adjuster screw usually located on the body of the brake lever.
- NOTE: a brake lever with too little 'travel' before hitting the handlebar may cause a linear brake to 'lock up' if the lever is pulled on hard. Longer lever 'travel' allows more progressive and better controlled braking. Adjust to suit your riding style, or ask your bicycle retailer to assist you make the correct adjustment.
- NOTE: all components of a linear brake must be compatible. Do not mix brake types.
- The brake lever for a linear brake is not designed to work with other types.

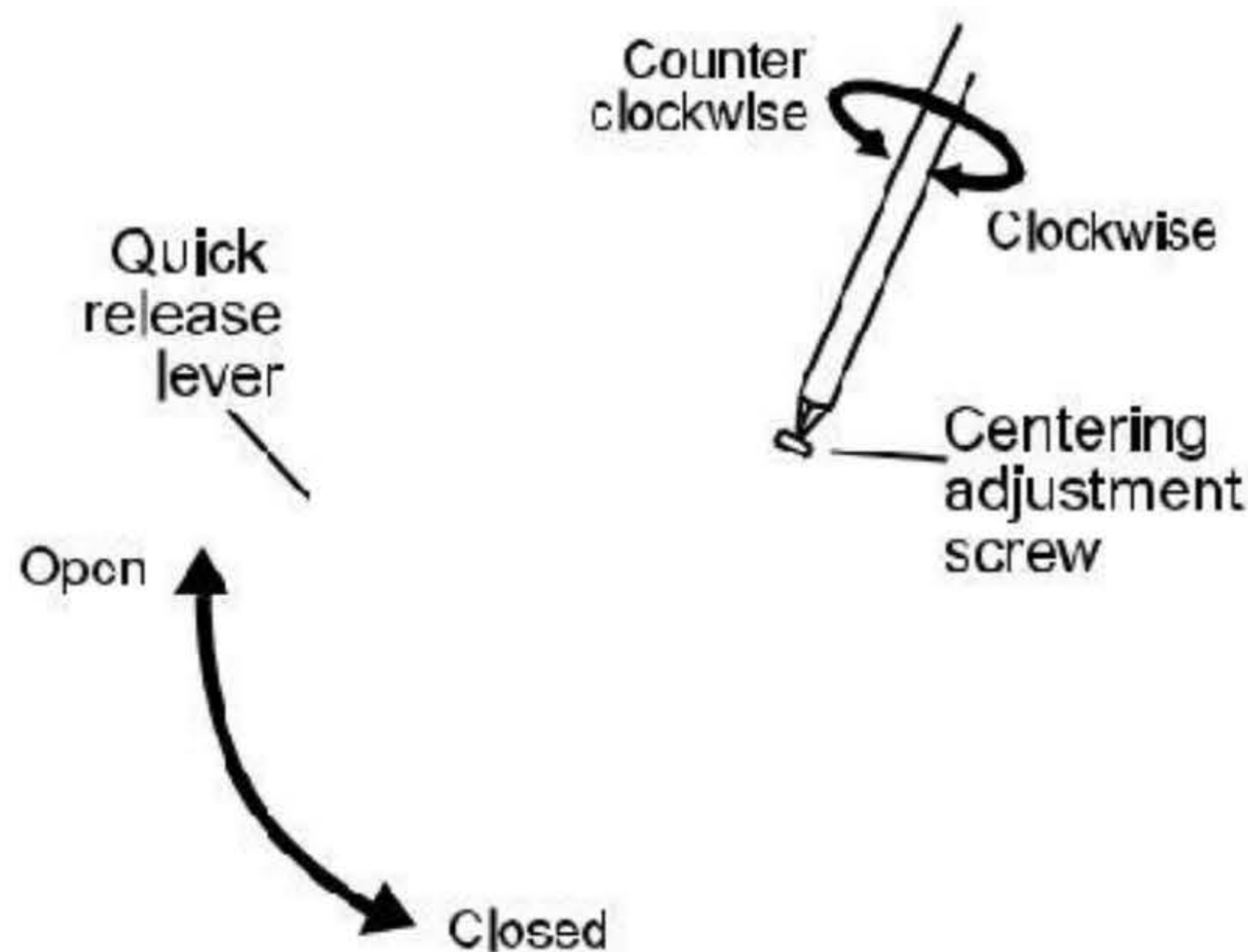

Cable adjustment bolt

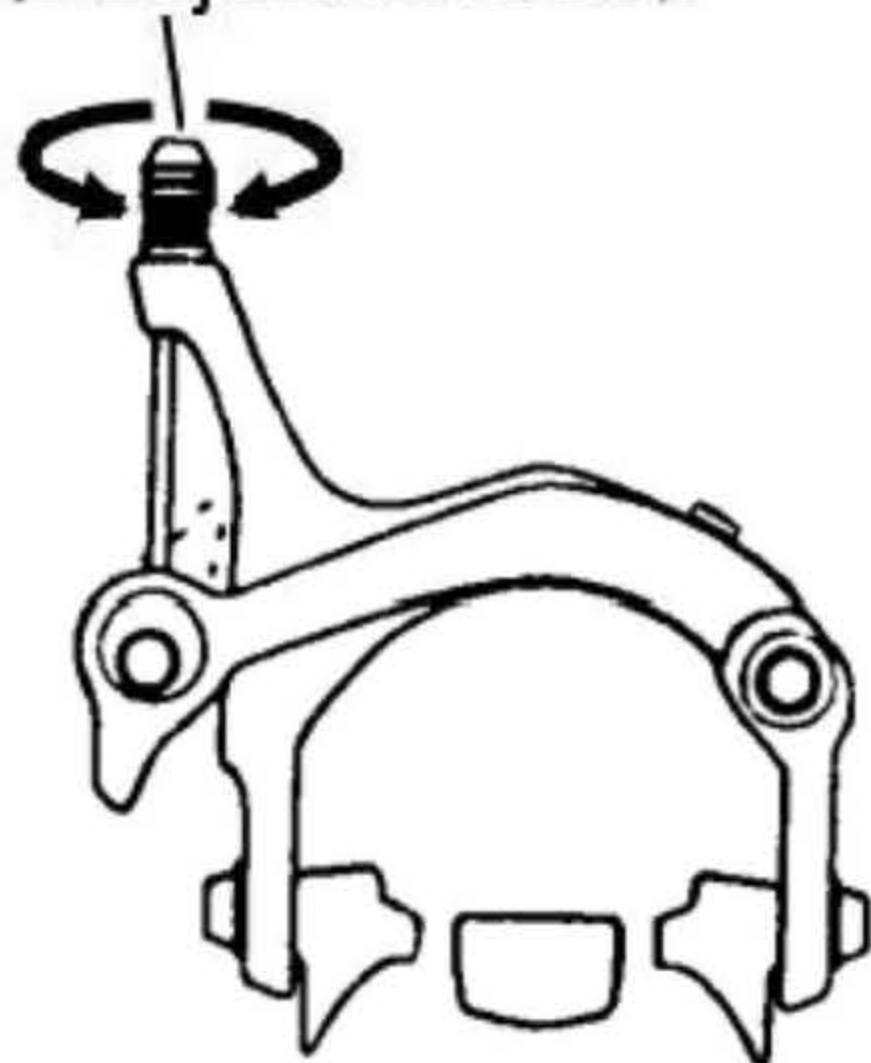
**SIDE PULL TYPE BRAKES (ROAD BICYCLES)**

When your side pull brake caliper is properly adjusted, you should have between 1-2mm gap between the brake block and the wheel rim.

- To centre the brake caliper use the centering adjustment screw to centre the brakes.
- Turn the screw **CLOCKWISE** to move the caliper to the right.
- Turn the screw **ANTI-CLOCKWISE** to move the caliper to the left.
- To set the gap between the blocks and the wheel rim use the Cable Adjustment Bolt.
- Turn the Adjustment Bolt **CLOCKWISE** to move the brake block away from the rim.
- Turn the Adjustment Bolt **ANTI-CLOCKWISE** to move the brake block towards the rim.
- Tighten the Cable Adjustment Bolt Lock Nut in a **CLOCKWISE** direction to set your adjustment.

- If your brakes shudder/squeal you need to adjust the toe in/out.
- As you need to realign the caliper arms to overcome this problem, your dealer should make this adjustment to your bike.

DISK STYLE BRAKES

The distinctive feature of disk brakes is the actual braking disk that is fixed to the wheel and the caliper unit attached to the front fork or rear wheel frame.

The brake is activated either by a cable or hydraulic system. Disk brake systems require special care of the disk itself, which can even be damaged by some bicycle parking racks.

Hydraulic systems may require special tools and adjustments. If in doubt about any adjustments or maintenance consult your bicycle retailer or the manufacturer's manual or specifications data. Some brands provide technical data on their websites.

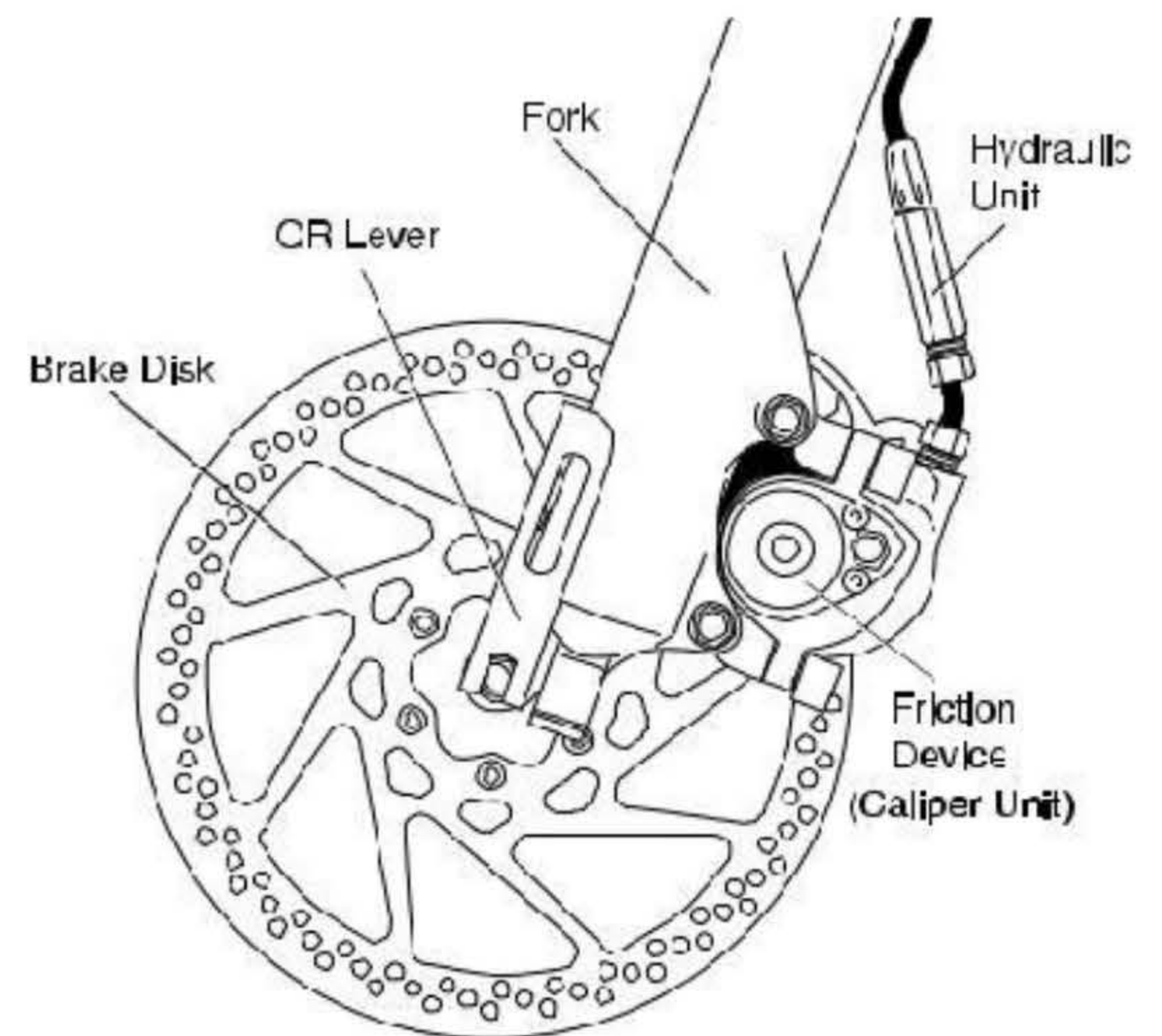

Disc Style Brake System

WARNING: Failure to properly maintain your brake system may result in a crash.



The brake Quick Release mechanisms are used to open the brake arm to assist in the removal / installation of wheels. The brakes will not function if the Quick Release is left open.

WARNING: Failure to firmly secure the Brake Quick Release Mechanism may cause a crash.



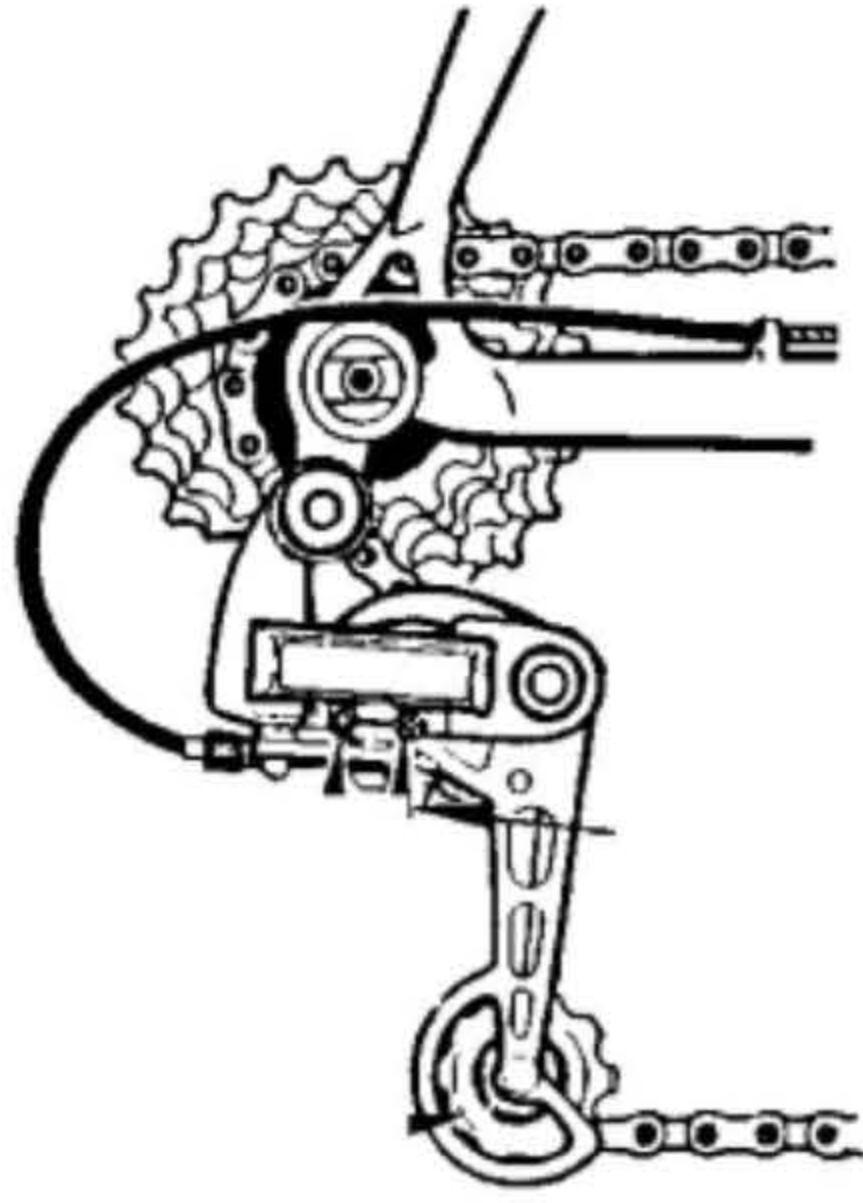

THE DERAILLEUR GEAR SYSTEM

The gear system on your bicycle consists of:

- A rear cluster (freewheel) which is attached to the rear wheel.
- A rear derailleur which moves the chain across the cluster to change the gear ratio.
- A front derailleur which moves the chain between the front chain rings to change the gear ratio.
- Gear levers which, when moved, change the gears.
- Control cables which attach the gear levers to both the front and rear derailleurs.
- A chain.

INTERNAL GEARED HUB

If your bicycle is fitted with a multi speed internal geared rear hub it may require special instruction for correct use, adjustment, care and maintenance. Read carefully the instruction manual supplied with your bicycle.

Ask your bicycle retailer for advice on use and maintenance of an internal geared hub.

NOTE: Unauthorised work may limit or void the warranty.

The purpose of derailleurs is to move from one sprocket to another to allow for a variety of gear ratios.

These ratios allow the rider to maintain a constant pedal revolution in a variety of road and speed conditions.

Ask your bicycle retailer for advice.

SHIFTING GEARS

Identify your gear levers from the diagrams.

Mountain / Cross bicycles have handlebar mounted shifters.

Road bikes use various types of shifters, these can include Integrated Brake and Gear Levers, rotating handlebar 'grip shift' systems or other variants. Ask your bicycle retailer to explain the gear changing procedure. Practice changing gears to gain confidence.

For smooth operation of all types of levers you must be pedalling forwards when changing gears.

NOTE: Some bicycles have gear levers mounted on the down tube (see diagram) of the frame. Using this type of mounting requires practice.

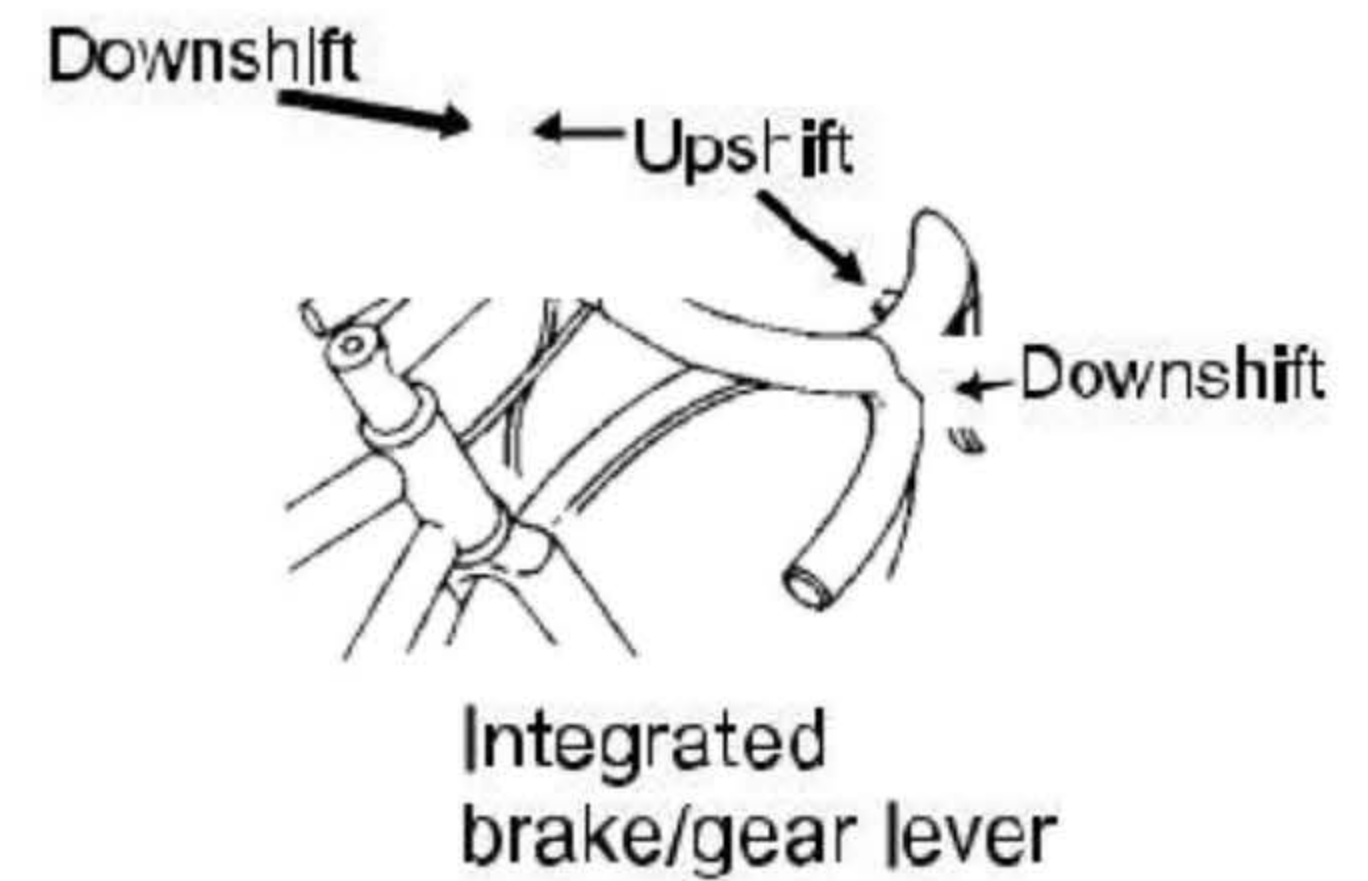
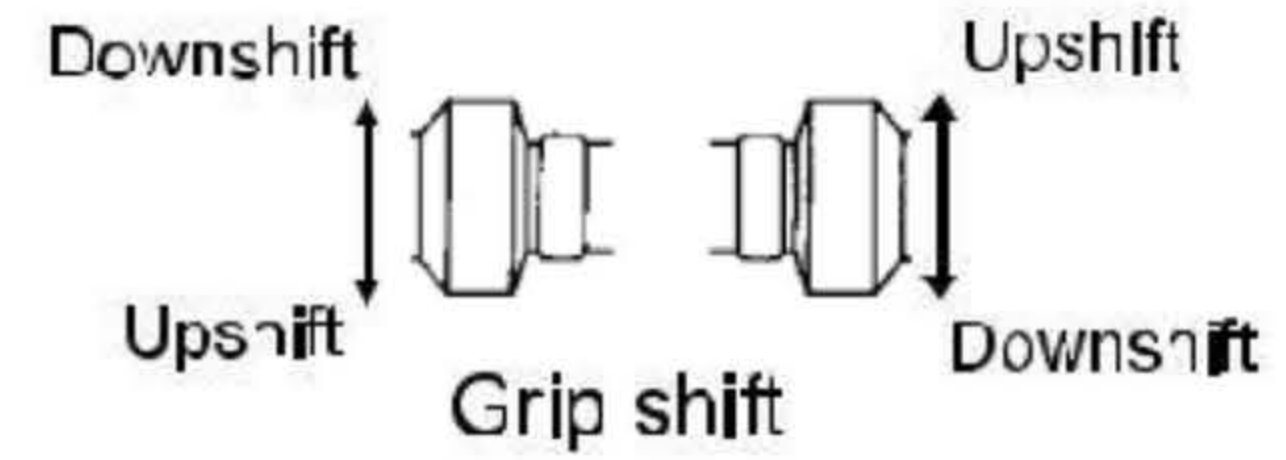
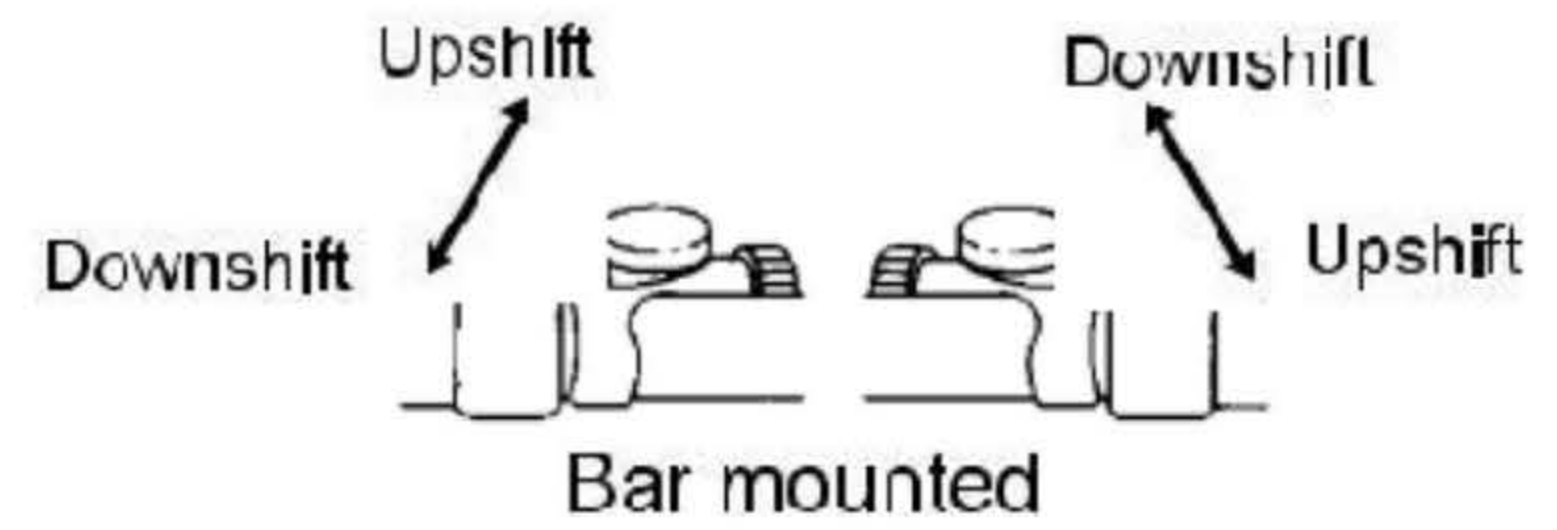

WARNING: Pedalling backwards whilst changing gears can jam the chain causing damage to your bicycle and/or a crash.



FRICITION GEAR SHIFT LEVERS

Friction levers are 'stopless' and hold the derailleur in place with simple force (tension). The amount of friction can be adjusted by means of the screw on top of the lever assembly.

If derailleur gears on your bicycle are indexed, each time you move the gear lever one click the derailleur travels a set distance to engage the next gear. This enables you easier and more accurate gear changing.



The gear shift principle: The **right hand** lever operates the rear gears. The **left hand** lever operates the **front chain ring shifter**.

When shifting through a wide range of gears, you may notice a noise as a result of the chain rubbing on the inside of the front derailleur cage.

This noise can be eliminated by moving the gear lever (friction systems) or adjusting the gear cable (indexing systems.)



WARNING: Avoid riding with the chain on both the largest front chain ring and the largest rear cog, smallest rear cog and small chain ring. This puts excessive strain on the chain and can damage derailleur parts.

Practice changing to a lower gear before stopping. This will assist easier starting at take-off.

As you gain more experience with your gear ratios you will be able to select the most suitable gear for the terrain and weather conditions.

NOTE: Your bicycle retailer will be able to assist you if you are uncertain about the steps in shifting gears.

DERAILLEUR ADJUSTMENT

From time to time your rear derailleur needs adjustment. You may need to tighten the derailleur cable to remove excessive cable slack. Excessive slack in the cable will cause the derailleur to miss shift.

Locate the Adjusting Barrel on the back of the derailleur.

Turn the barrel ANTI-CLOCKWISE half a turn and test the derailleur by changing gear.

Continue to turn the barrel until the chain is pitching correctly onto each gear.

NOTE: If you are not sure of these steps consult your bicycle retailer.

After the initial settling in period, if you have any adjustments that need attention, return to your bicycle retailer for advice.

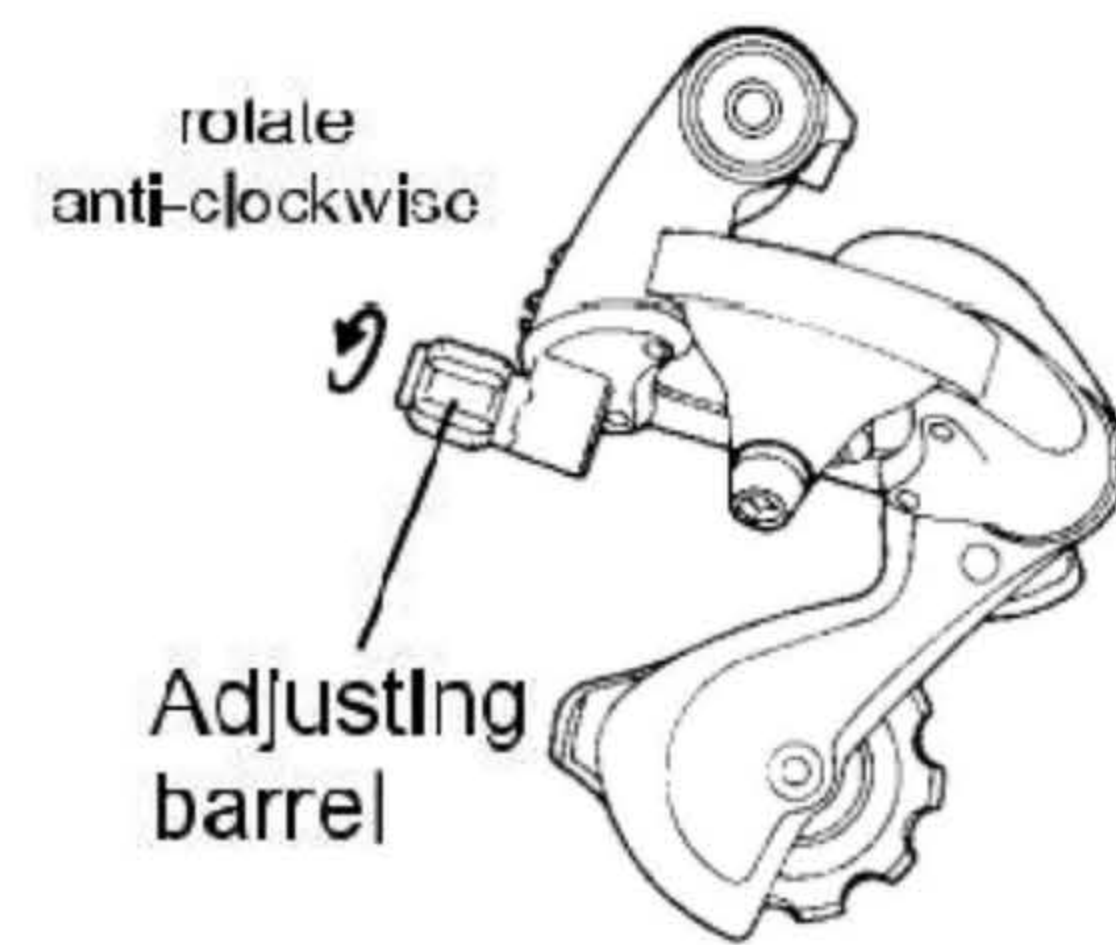

TOE CLIPS AND TOE STRAPS

Toe clips and straps are used to assist with the correct positioning of your feet on the pedals and to help your riding technique. The toe clip positions the ball of the foot over the pedal spindle, which gives maximum pedalling power. The toe strap, when tightened, keeps the foot engaged throughout the rotation cycle of the pedal.

Getting into and out of pedals with toe clips and straps requires skill which can only be acquired with practice. Do not ride in traffic or around other hazards until you can use toe clips and straps as a reflex action. Never ride in traffic with your toe straps tight.

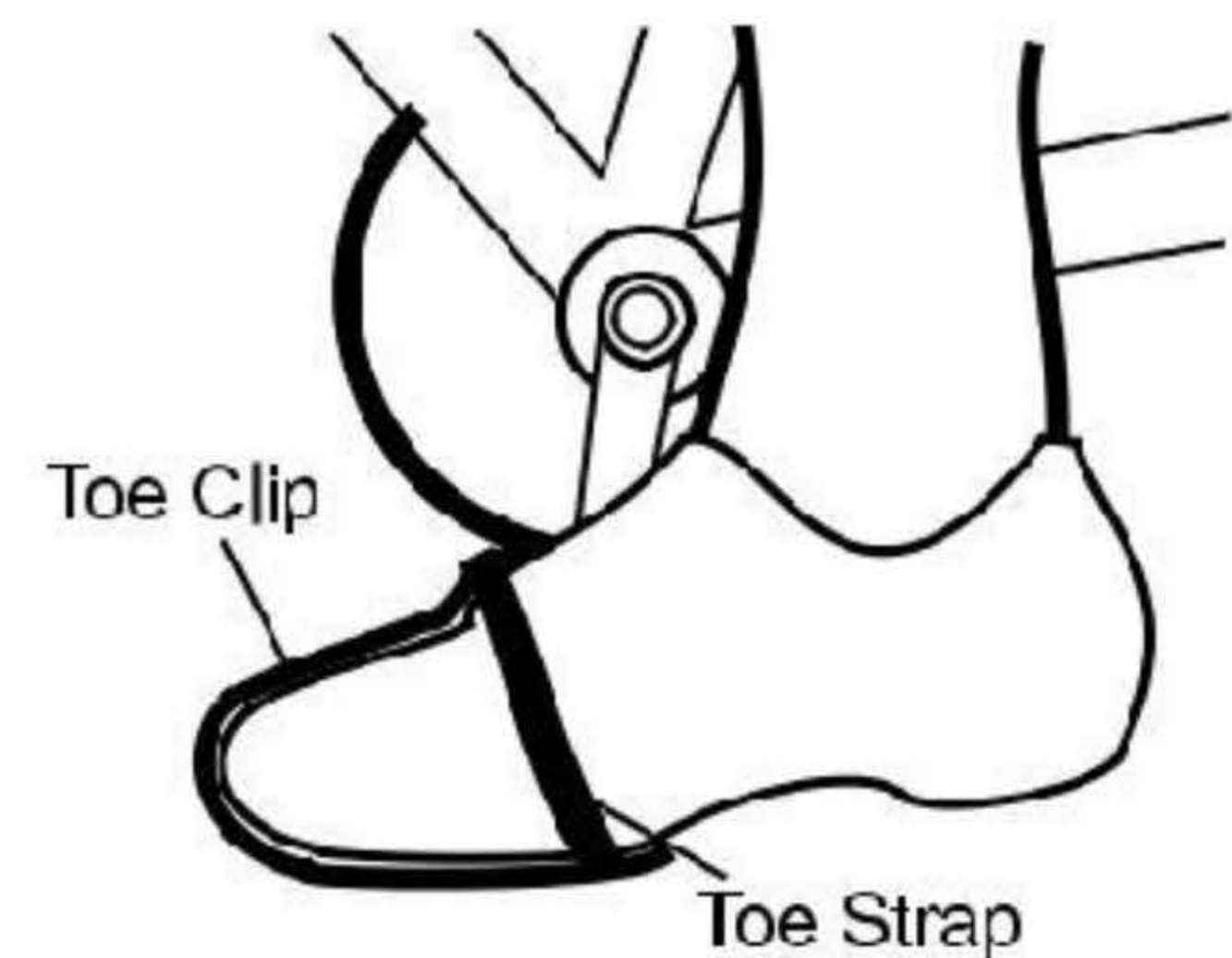

CLIPLESS PEDALS

Clipless pedals are usually adjustable. Your bicycle retailer can show you how to make this adjustment.

WARNING: Clipless pedals are intended for use with shoes specifically made to fit them and are designed to firmly keep the foot engaged with the pedal. Practice is required to learn to engage and disengage the foot safely.



TYRES AND TUBES

Bicycle tyres are available in many designs and specifications, ranging from general purpose designs to tyres designed to perform best under very specific weather or terrain conditions. Your bicycle retailer can help you select the most appropriate tyre and tube.

The size and pressure rating of a tyre is marked on the sidewall of the tyre. The part of this information which is most important to you is Tyre Pressure.

The best way to inflate a bicycle tyre to the correct pressure is with a bicycle pump. Your bicycle retailer can help you select an appropriate pump.



TAKE CARE: When using compressed air, over inflation can burst the tube and tyre. **Never** inflate a tyre beyond the maximum pressure marked on the sidewall of the tyre.

If the tyre pressure on your tyres is not in kilopascals please refer to the conversion table on Page 43.

Tyre pressure is given either as maximum pressure or as a pressure range. How a tyre performs under different terrain or weather conditions depends largely on tyre pressure.

Inflating the tyre to near its maximum recommended pressure gives the lowest rolling resistance; but also produces the harshest ride. High pressures work best on smooth, dry pavement.

Very low pressures, at the bottom of the recommended pressure range, give the best performance on loose or muddy surfaces.

Riding with your tyres underinflated can cause a puncture, the tyre deforms and pinches the inner tube between the rim and the riding surface. Cornering with underinflated tyres can cause the tyre to roll off the rim resulting in a fall.

Ask your bicycle retailer to recommend the best tyre pressure for your kind of riding.

TYRE VALVES

There are two kinds of bicycle tube valves in common use - the Schraeder Valve and the Presta Valve. The bicycle pump you use must have the fitting appropriate to the valve stems on your bicycle.

The Schraeder is like the valve on a car tyre. To inflate a Schraeder valve tube with compressed air or with a bicycle pump, remove the valve cap and push the air hose or pump fitting on to the end of the valve stem. To let air out of a Schraeder valve, depress the pin in the end of the valve stem with the end of a key or other appropriate object.

The Presta valve has a narrower diameter and is only found on bicycle tyres. To inflate a Presta valve tube using a Presta headed bicycle pump:

- remove the valve cap
- unscrew (anti-clockwise) the valve stem lock nut
- push down on the valve stem to free it up
- push the pump head on to the valve head, and inflate.

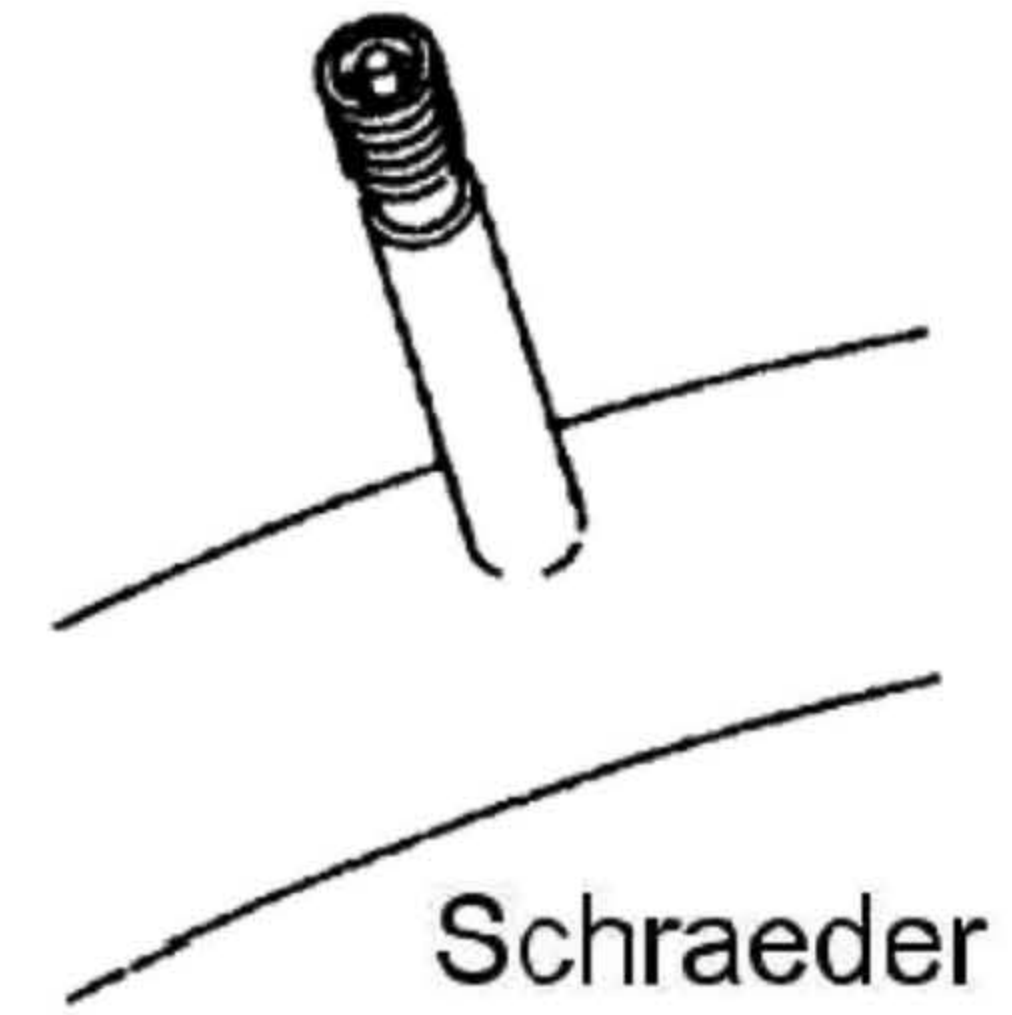

Schraeder

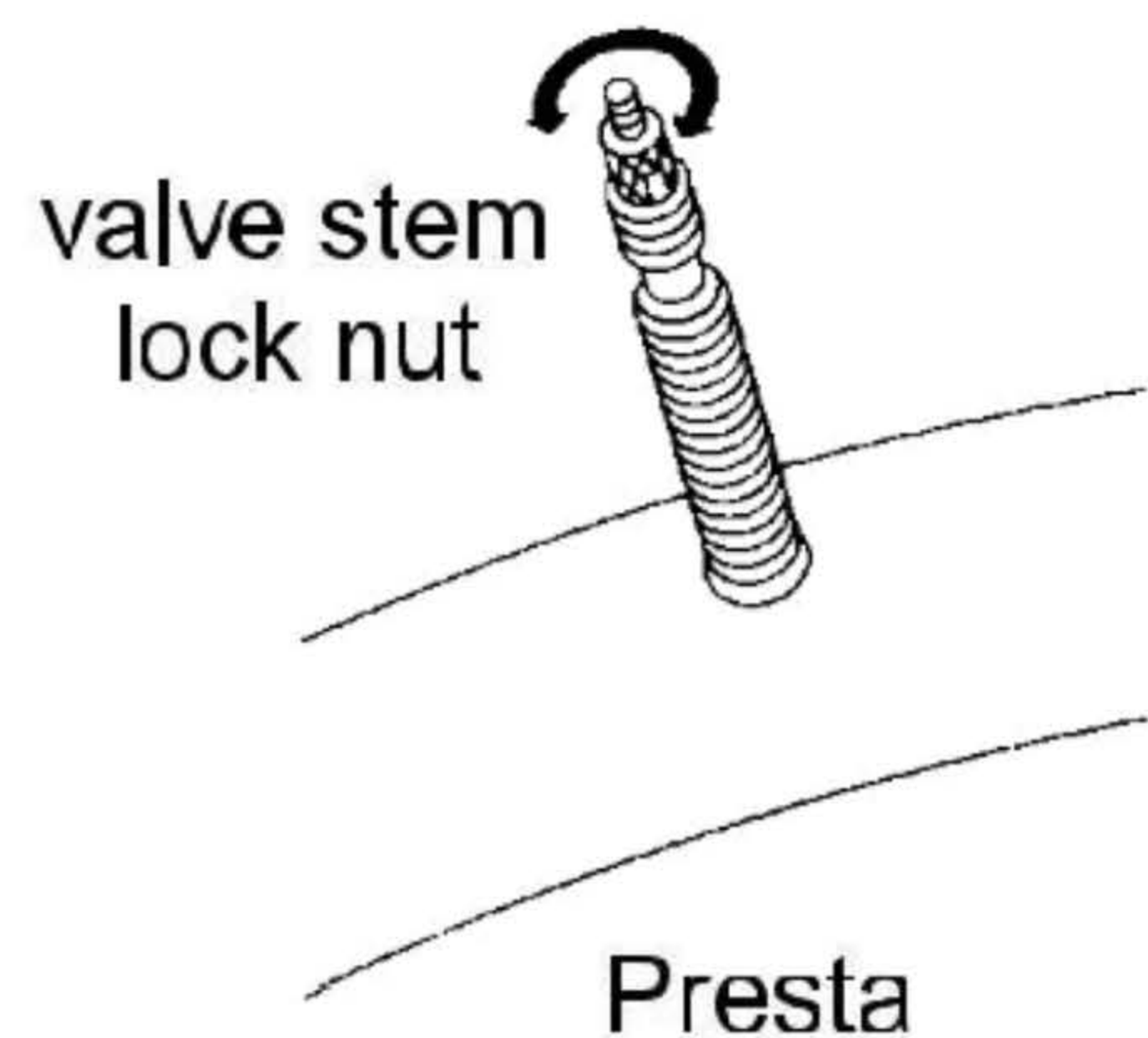
valve stem
lock nut

Presta

BICYCLE SUSPENSIONS

Some bicycles come equipped with suspension systems. There are many different types of suspension systems.

If your bicycle has a suspension system ask your bicycle retailer to explain care and use. Return your bicycle for regular maintenance and adjustment of the suspension system.





NOTE: Changing suspension adjustment can change the handling and braking characteristics of your bicycle. Read and follow manufacturer's instructions

Not all bicycles can be safely retrofitted with suspension systems. Check with your bicycle retailer.

3.1 MAINTAINING YOUR BICYCLE

SERVICE AND BASIC MAINTENANCE

Bicycles perform best when they are kept clean, lubricated and serviced regularly.

How much of your bicycle's service and maintenance you can do yourself depends on your level of skill and experience, and whether or not you have the special tools required.



Warning: Some bicycle service and repair tasks require special knowledge and tools. Do not begin any adjustments or service on your bicycle if you have doubt about your ability. Unauthorised or incorrect service and repairs may void product warranty.

CLEANING

Mud and dust can be highly abrasive. Regular cleaning will help maintain your bicycle in good condition.

Always dry and lubricate your bicycle after washing to prevent rust.

LUBRICATION

Keep your bicycle regularly lubricated for good performance and durability. Lubrication reduces friction and helps protect against rust.

All bearings and other moving parts require regular appropriate lubrication:

- Grease type lubrication:- bearings in head stem, wheels, bottom bracket and pedals (requires disassembly refer to your bicycle retailer).
- Oil type lubrication:- Brake and derailleur pivot points and jockey wheels, chain, free wheel.

For advice on appropriate special lubricants, ask your bicycle retailer.

3.2 MONTHLY SERVICE CHART

Monthly servicing of your bicycle is recommended. This consists of lubrication and adjustment of components.

Use the correct type of lubricants and tools, service the bicycle's components in logical groups and clean before you start.

TYRES AND TUBES

- Clean the tyres and inspect treads for wear.
- Remove any debris from tread or walls.
- Check tyre pressure is correct.
- Replace faulty tubes.

WHEELS

- Clean rims and check they are not dented or dimpled.
- Check rims for trueness and spokes for evenness of tension.
- Replace any bent or broken spokes.

CHAIN

- Check chain for excessive wear or stretching.
- Check for any stiff links.
- Use recommended lubricant.

BRAKES

- Check brake block and brake lever mounting bolts.
- Check brake blocks for wear. Replace if necessary.
- Check block toe-in is correct.
- Lubricate brake pivot bolts and adjust where necessary.

GEAR AND BRAKE CABLES

- Inspect all cable housing for damage. Replace if necessary.
- Clean and examine all cable wires for kinks and frayed ends. Replace if necessary.
- Adjust barrel adjusters and/or cable anchor bolts to compensate for cable stretch.

HUBS

- Check front and rear hub bearings for excess play or binding. Have adjustable cup-and-cone bearings, tightened or loosened if necessary.
- Check hubs are correctly lubricated.
- Tighten hub axle nuts and check quick release levers.

FRONT AND REAR DERAILLEURS

- Clean derailleur cages bushings.
- Check the accuracy of the indexing and adjust cable tension at barrel adjusters and/or cable anchor bolts as required.

CRANK/CHAINRINGS AND FREEWHEELS

- Clean chainrings; check they are true and have no excessively worn, or broken teeth.
- Check crank arms are tight on bottom bracket spindle.
- Clean and lubricate freewheel and check for wear.
- Check freewheel sprockets for worn or broken teeth.

BOTTOM BRACKET/AXLE

- Test bottom bracket bearings for excess play or binding.
- Check that the locknut is tight.
- Check bottom bracket is correctly lubricated.

HEADSET

- Check headset for excess play or binding.
- Check the locknut is tight.

PEDALS

- Check pedal bodies are not cracked.
- If pedals are loose, tighten the mounting bolts firmly.
- Inspect toe clips/toe straps for damage.

GENERAL

- Check frame alignment and all the tubes for dents or damage.
- Check all bolts and nuts are secure. Tighten bolts with the correct tools.

CAUTION: Alloy bicycle parts can be damaged by overtightening.

STORAGE

The best protection for your bicycle is to store it under cover in a dry environment and away from corrosive materials such as battery acid and swimming pool chemicals. Thoroughly dry off your bicycle after use in wet conditions. Wax or lubricate as required.

Failure to follow this procedure may lead to rust and corrosion of metal work.

4. ADDITIONAL INFORMATION HELPFUL HINTS, SPECIAL INSTRUCTIONS AND WARRANTY

4.1 ABOUT YOUR BICYCLE RETAILER

Your bicycle retailer will help you to select bicycle accessories for the kind of riding you wish to do. Bicycle shop staff have the knowledge, tools and experience to give you reliable advice and provide maintenance services. If you have a problem with your bicycle or your riding, talk to your bicycle retailer.

4.2 SPECIAL INSTRUCTIONS FOR CARE OF CARBON FIBRE BICYCLES

A carbon fibre frame requires special care due to the nature of its construction.

- Never clamp the bicycle using any of the carbon fibre frame tubes. Use the seat post to hold the frame during assembly.
- Do not use any solvents on the frame. Clean only with a mild detergent and water.
- Do not paint the frame.

- Avoid scratches and direct impacts to the frame. If you are involved in a mishap, or your bicycle is scratched during use, immediately see your bicycle retailer for inspection of the damage.
- Use a chain protector to lessen the chance of chipping the carbon fibre tubing.
- Use the manufacturer's recommended size seatpost and headset. Do not attempt to alter the original sizes of these parts.
- Avoid overtightening of the seatpost.
- Any other questions? Please contact your bicycle retailer.

4.3 TOOLS AND BICYCLE ASSEMBLY

Should you intend to undertake maintenance the following tools are considered to be the basic requirement:

- Adjustable wrench 5-10cm
- Adjustable wrench 32cm
- Flat screw driver 15mm
- Phillips head screw driver 15mm
- Allen Key set 2mm-6mm
- Set of open end spanners 7-17mm
- Set of tyre levers
- Chain link remover
- Wire cutters
- Torque wrench

All nuts and bolts should be checked on a regular basis for tightness. To assist in achieving the correct tension when tightening nuts and bolts the use of a torque wrench is recommended. Apply the following torque for the nominated parts of your bicycle:

Front Wheel Nuts	22-27 Newton Metres
Rear Wheel Nuts	24-29 Newton Metres
Seat Binder Nut	12-17 Newton Metres
Seat Pillar Clamp Nut	4-19 Newton Metres
Brake Anchor Nut	7-11 Newton Metres
Handle Bar Clamp Nut	5-19 Newton Metres
Head Stem Expander Bolt	17-19 Newton Metres
Crank Cotter Pin Nuts	5-10 Newton Metres
Brake Centre Bolt	5-7 Newton Metres
Pedals	35-40 Newton Metres

The following checklist presumes a bicycle which is assembled except for the handlebar & stem, brake and gear levers, saddle and seat stem, pedals, frame reflectors and wheels.

- Fit wheels to frame and align. Secure axle nuts or Quick Release (QR) mechanism.
- Lubricate handlebar stem, slacken wedge bolt and wedge, slide into head set to below minimum insert mark, align square to front wheel, tighten wedge bolt. Tighten wedge bolt. Check head stem lock nut is tight and that the handlebar will not rotate.
- If your bicycle is equipped with a 'threadless' headset, check fitting adjustments with your bicycle retailer. DO NOT OVER TIGHTEN the two securing bolts.
- Slide brake and gear lever assemblies onto handlebar in correct configuration. Tighten locking bolts. Adjust brake assembly cables and align brake blocks for prescribed clearance.

- Fit handlebar tape or handgrips, stop ends to bar if bar is taped, and bell.
- Assemble saddle onto seat stem. Tighten fixing nuts. Lubricate seat stem and insert in seat tube to below minimum insert mark. Tighten seat binder bolt or Quick Release mechanism.
- Fit pedals to crank in correct order; pedal marked R on the right hand side; L on the left.
- Fit frame mounted reflector brackets and reflectors. Align reflectors to vertical. Tighten all bolts. Confirm that wheel reflectors are fitted.
- Recheck that all components are correctly assembled, all bolts, nuts and QR correctly secure. Check that handlebar and saddle cannot be swivelled sideways.
- Check derailleur gears/hub gears for correct operation; adjust to manufacturer's specification. Check both brakes for correct operation.

WARNING: If you are unsure about correct assembly and/or adjustment, seek advice from a qualified bicycle mechanic.

'Threadless' head sets: some bicycles, especially those equipped with a front fork suspension system, are fitted with a 'threadless' head set. Special tools and/or

procedures may be required to correctly secure such devices.



4.4 LOCK YOUR BICYCLE

If you lock up your bicycle, it is much less likely to be stolen. Nearly all bicycles stolen were not locked at the time.

Lock your bicycle to something solid e.g. a tree, a parking meter or a post. Make sure the bicycle cannot be lifted from the post or the post lifted out of the ground or pavement. Use a good quality U-Lock.

A good quality, hardened steel U-lock is your bicycle's best protection from theft. U-locks are more secure than cables or chains with padlocks. Combination locks provide least security.

Make sure the lock or cable is not in a position which makes it easy to be removed or cut.

- A front wheel with Quick Release can be removed and locked to the frame.
- A good quality U-Lock may be the most secure device for locking your bicycle.
- Bicycle parking rails should comply with Australian Standard AS2890.3 (1993).
- Refer to Guide to Traffic Engineering Practice Part 14 - Bicycles (AUSTROADS 1999).
- www.bikeoz.com.au - provides additional information.
- www.cyclingpromotion.com.au - helping you get more out of your riding.

4.5 KEEP A RECORD OF YOUR BICYCLE

Take a colour photograph of your bicycle, write the frame number on the back of the photograph and keep it in a safe place. Less than one in ten stolen bicycles is returned, partly because the owner cannot describe the bicycle. Engraving a registration number on the bicycle will also help. The police, Neighbourhood Watch and service clubs run bicycle registration programs.

If you keep a record of the details of your bicycle it will greatly increase the possibility of getting it back should it be lost or stolen.

Remember the advice about LOCKING YOUR BICYCLE. A good quality lock is cheap insurance.

See the record chart at end of this manual.

WHAT IS IT CALLED?

Although bicycle components vary in design, weight and method of use, basically all bicycles are the same.

A bicycle is made up of a frame, wheels, drive train, brakes, stem, handle bars and saddle. Frames must show a makers ID label.

Familiarise yourself with the bicycle's terminology; it will make basic maintenance instructions much easier to follow.

TYPICAL PARTS OF A BICYCLE

NOTE: Not all components nor all bicycle types are shown.

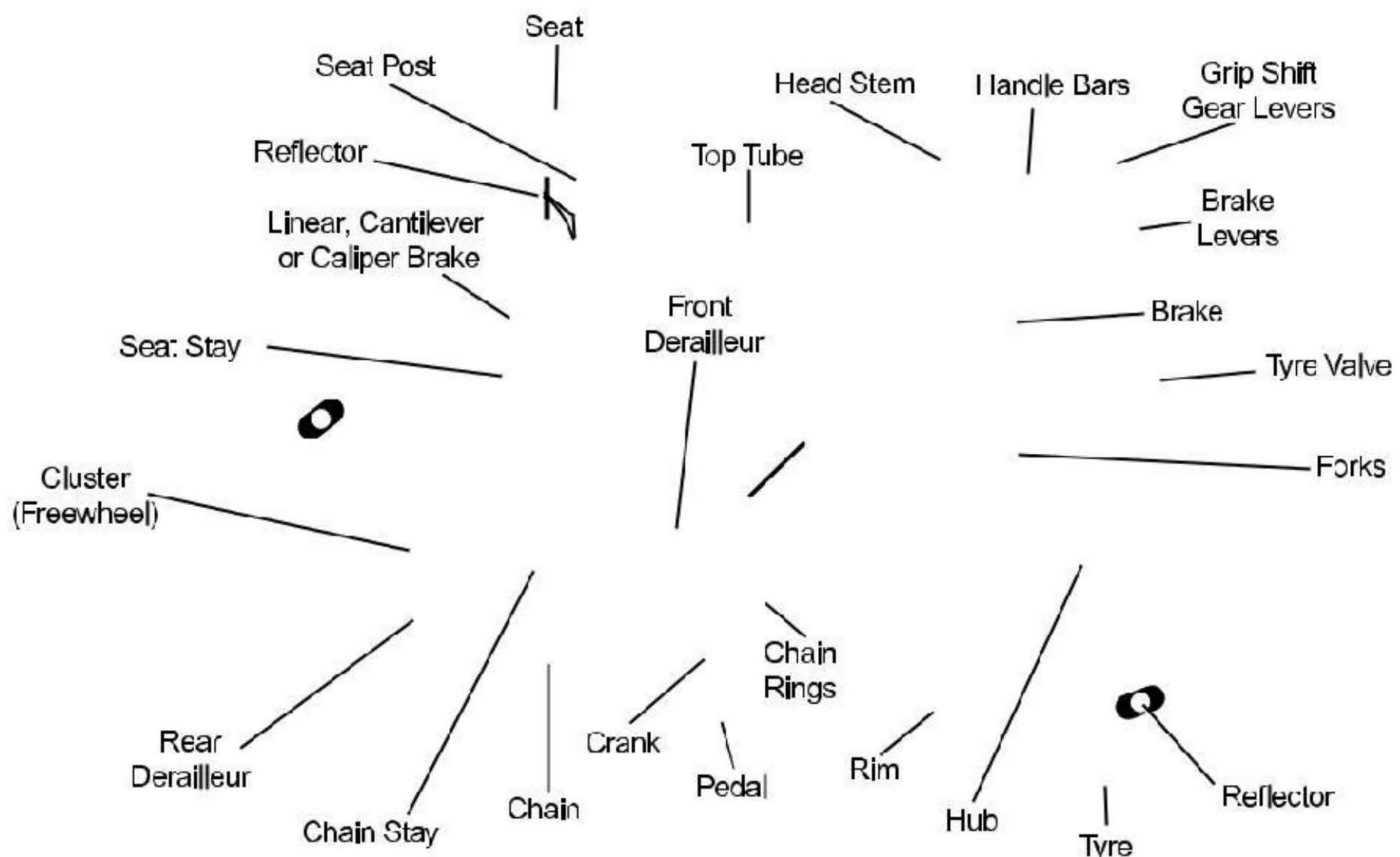

WARNING: Handlebar handgrips or tube-end plugs should be replaced if damaged. Unprotected tube-ends can cause injury. Bicycles used by children should especially be checked to ensure bar end handgrips are in good condition.



FOR ALL TYPES

Where a suspension unit, disk and / or hydraulic brake units, multi-gear hub, electric gear changing system, etc, are fitted, consult manufacturers specification and warranty documents. For correct selection and repair advice, ask your bicycle retailer. Unauthorised work may limit or void a product warranty.

1. SAFETY PRECAUTIONS

1.1 FITTING YOUR BICYCLE FOR A SAFE RIDE

To ride safely and comfortably a bicycle and its equipment must be matched properly to the size and skills of the rider.

FITTING FOR LEG LENGTH

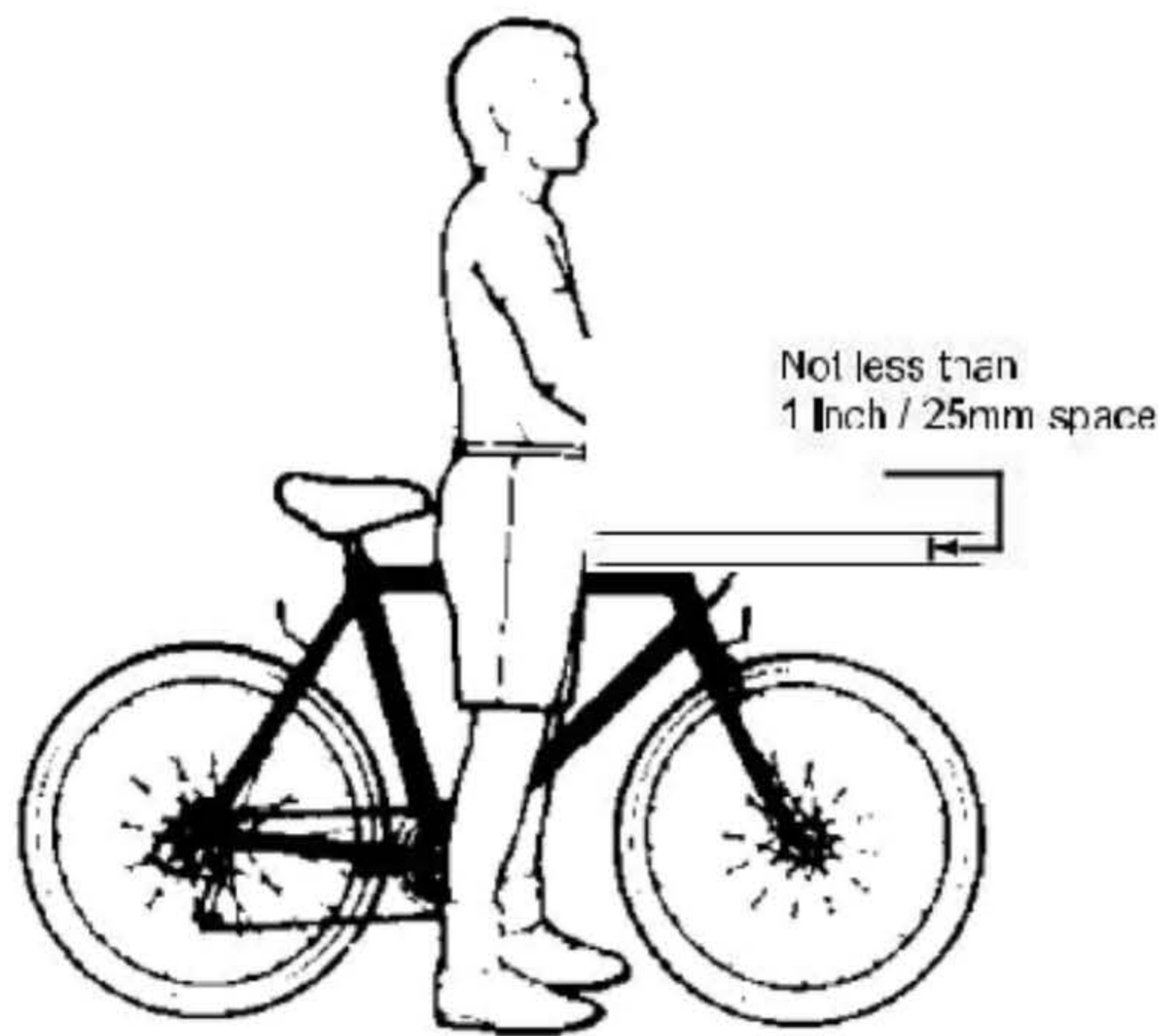

FRAME SIZE	RIDER LEG LENGTH
14.5"	25 - 26"
15"	26 - 27"
16"	27 - 28"
17"	28 - 30"
18"	29 - 31"
19"	30 - 32"
20"	31 - 33"
21"	32 - 34"
22"	33 - 35"
23"	34 - 36"
24"	35 - 37"
25"	36 - 38"

MAKE SURE THE BICYCLE FITS

A bicycle that is too big or too small for the rider is hard to control and can be uncomfortable. If your bicycle does not fit properly, you may lose control and fall.

TROUBLESHOOTING CHART (CONTINUED)

PROBLEM	POSSIBLE CAUSE	REMEDY
Chain jumping off	Chainring bent	Replace Chainring
	Chainring loose	Tighten mounting bolts
	Chainring teeth bent or broken	Replace Chainring
	Rear or front derailleur side-to-side travel out of adjustment	Adjust derailleur travel
Constant clicking noises when pedalling	Stiff chain link	Lubricate or replace link
	Loose pedal spindle / bearings	Adjust bearings / spindle nut
	Loose bottom bracket spindle / bearings	Adjust bottom bracket
	Bent bottom bracket / pedal spindle	Replace bottom bracket / spindle
	Loose crank	Tighten crank bolt
Grinding noise when pedalling	Pedal bearings too tight	Adjust bearings
	Bottom bracket bearings too tight	Adjust bearings
	Chain fouling derailleurs	Adjust chain line
	Derailleur jockey wheels dirty / binding	Clean and lubricate jockey wheels
Freewheel does not freewheel	Freewheel internal pawl pins are jammed	Lubricate. If problem persists, replace freewheel

Regular maintenance by your bicycle retailer is recommended

KEEP A RECORD OF YOUR NEW BICYCLE

OWNER: _____

ADDRESS: _____

POSTCODE: _____

TEL: _____

BRAND & SERIAL NUMBER: _____

MODEL: _____

FRAME STYLE: _____

FRAME SIZE: _____

FRAME COLOUR(S): _____

WHEEL SIZE: _____

TYRE SIZE & TYPE: _____

BRAKE TYPE & BRAND: _____

TRANSMISSION BRAND: _____

SADDLE BRAND: _____

OTHER ACCESSORIES (LIST & BRAND NAMES):

PURCHASED FROM (SHOP NAME): _____

SHOP ADDRESS: _____

TEL: _____

DATE OF PURCHASE: _____

/ /

PRICE PAID: \$ _____

Remember the advice about LOCKING YOUR BICYCLE.

A good quality lock is cheap insurance.

**WARNING****VERY IMPORTANT**

In the interests of safety it is recommended that you have this bicycle assembled by a skilled bicycle mechanic.

This is a partially assembled bicycle requiring the attachment of the following parts in accordance with manufacturer's instructions.

FAILURE TO ASSEMBLE THE BICYCLE CORRECTLY MAY AFFECT YOUR WARRANTY.

**COMPONENTS TO BE ASSEMBLED**

- HANDLE BARS & STEM ASSEMBLY
- FRONT WHEEL
- SEAT & SEAT POST ASSEMBLY
- BRAKES- REFLECTORS & REFLECTOR BRACKETS
- PEDALS & BELL

**TOOLS REQUIRED**

- 4,5,6 & 8mm ALLEN KEYS
- 8-17mm SPANNER SET
- PLIERS
- PHILLIPS SCREWDRIVER
- FLAT HEAD SCREWDRIVER

WE RECOMMEND THAT A TORQUE WRENCH BE USED



Check us out and share an image of you and your bike using [#reidcycles](https://www.instagram.com/explore/tags/reidcycles) or [@reidcycles](https://www.instagram.com/reidcycles)



Keep up with the latest goings on with Reid on [facebook.com/reidcycles](https://www.facebook.com/reidcycles)

