

# JACLYN *J* SMITH™

---



---

## USE AND CARE GUIDE

### Clermont Umbrella - Green

Product code: 0-08739073-8

UPC code: 471 333112 144 8

Vendor Item: SC-K-502U-G

Date of purchase: \_\_\_\_/\_\_\_\_/\_\_\_\_

## Thank you for your purchase

---

### Thank you for your purchase

We are pleased that you have chosen Kmart for your outdoor furniture purchase. We hope that you enjoy the unmatched quality, comfort, and style of your new patio set. Every piece is meticulously considered all the way down to the smallest details, exclusively for you, by our world class design team. We know you have a choice when it comes to your patio furniture needs, so from our team to yours, thank you for letting us be a part of your outdoors.

## Table of Contents

---

<b>Table of Contents</b> .....	<b>2</b>
<b>Safety Information</b> .....	<b>2</b>
Set Up your Furniture Properly.....	2
Examine your furniture.....	2
<b>Warranty</b> .....	<b>3</b>
<b>Care and Maintenance</b> .....	<b>3</b>
<b>Pre-Assembly</b> .....	<b>4</b>
Planning Assembly.....	4
<b>Assembly Instructions</b>	
<b>Package Contents</b> .....	<b>4</b>
<b>Umbrella</b> .....	<b>4</b>
<b>Customer Service</b> .....	<b>4</b>

## Safety Information

---

### SET UP YOUR FURNITURE PROPERLY

- Ensure that all parts are assembled properly and fully tightened as per the instructions.
- When placing in the desired location, ensure that all legs are resting on the same surface. You may adjust the legs levelers as required to ensure that the item stands in a rigid position.
- To prevent damage to your table, always use a umbrella base with your umbrella.

### EXAMINE YOUR FURNITURE

- Examine occasionally to ensure that there are no loose parts. If loose parts are found, they must be retightened fully before additional use.

## Warranty

### **WARRANTY**

We warrant our products to be free of manufacturing defects to the original purchaser for the period listed below. We reserve the right to make substitutions with similar merchandise, if the model in question is no longer in production.

### **EXCLUSIONS**

This warranty does not cover: Furniture used for commercial or non-residential purposes; failures caused by improper care; unreasonable or abusive use; freeze damage; acts of nature. Steel products are not covered against rust. Tempered glass table tops are not covered against breakage.

### **FINISH**

Frame finish is warranted to be free of manufacturing defects for a period of one (1) year. Discoloration or fading of the finish as a result of exposure to the elements, chemicals, or spills is not covered.

### **FABRIC**

Fabric is warranted to be free of manufacturing defects for a period of one (1) year. Discoloration or fading of the finish as a result of exposure to the elements, chemicals, or spills is not covered.

### **FRAMES**

Frame is warranted to be free from defects in material or workmanship for a period of one (1) year for steel frame.

### **FREIGHT & PACKAGING**

Freight and packaging are the responsibility of the original purchaser.

### **CUSTOMER SERVICE**

In case of a problem, call 1-800-457-4652 between 9:00 am to 5:00 pm Eastern standard time Monday through Friday or contact us at [www.numarkcustomerservice.com](http://www.numarkcustomerservice.com) for any question or problems you may have.

## Care and Maintenance

- Though its powder-coated finish is rust-resistant, steel is prone to rust over time with exposure to the elements. In case of rust or scratches, lightly sand the affected area and apply touch-up paint. To maintain the finish periodically apply wax with a soft cloth.
- Wash frames with a mild solution of soap and water; rinse thoroughly. Do not use bleach or solvents.
- Wash umbrella and pole with a mild solution of soap and water; rinse thoroughly. Dry pole completely, and allow umbrella to drip-dry in the open position. Do not use bleach or solvents on fabric. Umbrella should be closed when not in use. Umbrella should be removed and stored in the event of wind, rain, hail, sleet, snow, or any other inclement weather. To prevent damage to your table, always use a umbrella base with your umbrella. Store indoors during winter months.

## Pre-Assembly

### PLANNING ASSEMBLY

Read through all the instructions before beginning assembly. Unpack and identify all the parts. Place them on a flat, non-abrasive surface. Assembly by one person is recommended.

## Assembly Instructions

### Package Contents

ITEM	DESCRIPTION	QUANTITY
A	Umbrella Top	1
B	Bottom Pole	1

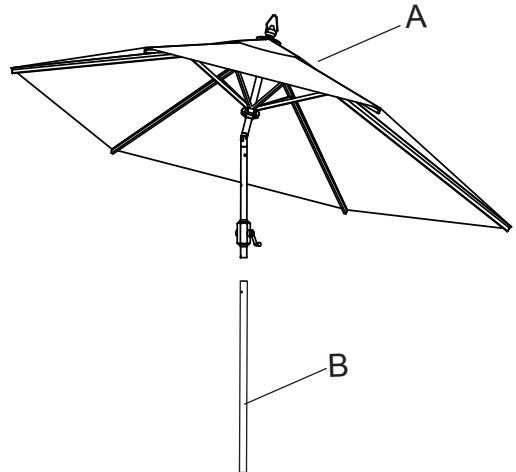

### 1 Inserting the umbrella top into the bottom pole

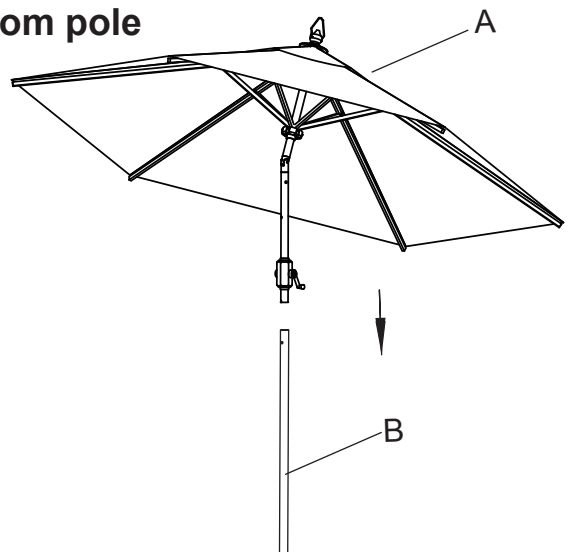

Please refer to part numbers when reordering

For questions or comments about product:

Call toll-free: 1-800-457-4652

between 9:00 am to 5:00 pm Eastern standard time Monday through Friday  
or contact us at [www.numarkcustomerservice.com](http://www.numarkcustomerservice.com)

Made in / Hecho en CHINA for Kmart Corporation, Hoffman Estates, IL 60179

See our extensive assortment of outdoor living products  
on-line at [www.sears.com](http://www.sears.com) and [www.kmart.com](http://www.kmart.com)