



SUSPENSION SETUP GUIDE

For your Pivot suspension equipped bike to pedal and descend at its best, it is important to tune the suspension properly. Use this guide to familiarize yourself with the Pivot suspension setup procedures and as a baseline for tuning to your individual riding needs. Our set up guide may differ slightly from Fox's stock guidelines because our settings are calibrated in the rocky southwest terrain. Consider these recommendations as a starting point. If you are riding on steeper terrain, or smoother trails, you may require slightly more rebound and compression damping.



Scan to follow along with Pivot Factory Racing star Bernard Kerr as he shows you how to set up sag.

TABLE OF CONTENTS

1. Fox Float DPS, Float DPX2, & Float X	2
Setting Sag on Fox Float DPS, Float DPX2, & Float X	2
Setting Damping Adjustments on Fox Float DPS	3
Setting Damping Adjustments on Fox Float DPX2	4
Setting Damping Adjustments on Fox Float X	5
2. Fox Float X2 Air	6
Setting Sag on Fox Float X2	6
Damping Adjustment on Fox Float X2	6
Rebound & Compression Damping Setting Table for Fox Float X2	7
Setting Damping Adjustment on Fox Float X2	7
3. Fox DHX2 Coil	8
Setting Sag on Fox DHX2 Coil	8
Damping Adjustment on Fox DHX2 Coil	9
Rebound & Compression Damping Setting Table for Fox DHX2 Coil	9
Setting Damping Adjustment on Fox DHX2 Coil	9
4. Fox Float Air Fork	10
Setting Sag on Fox Float Air Fork	10
Setting FIT4 Damping Adjustment on Fox Float Air Fork	11
Setting GRIP Damping Adjustment on Fox Float Air Fork	12
Setting GRIP2 Damping Adjustment on Fox Float Air Fork	13

1. Fox Float DPS, Float DPX2, & Float X

Setting Sag on FOX Air Shocks

1. Always set sag with the blue compression lever to the open position. (fig. 1)
2. If your shock has additional compression and rebound adjustments ensure they are adjusted to be fully open, compression to the softest setting, and rebound to its fastest setting.
3. If it is not installed already, attach the sag indicator to the bottom of the shock body using the provided zip-tie and carefully cut the excess.(fig. 2)
4. Find a level surface and something to steady yourself while mounted on the bike so you can be on the pedals in a seated position. It may be easier to have a partner hold your bike steady from the front, by holding the handlebars while you are in your riding position.
5. While standing on the pedals, sit down hard into the saddle to cycle the suspension well into the stroke. This will ensure the bike comes to rest at the natural sag setting with the rider in the saddle.
6. While in the saddle and not moving, slide the O-ring up into position against the air can. (fig. 3)
7. Once the O-ring is set in place, slowly step off the bike so as not to move the O-ring.
8. Make adjustments to the sag by removing or adding air so that steps 4-7 result in the O-ring lining up with the red line on the sag indicator (fig. 4). When adjusting air pressure in the shock, cycle the shock before re-checking sag, so the large Evol negative air chamber equalizes pressure with the main chamber each time air is added or removed. You can do this by pushing down on the saddle several times to compress the shock past the sag point.
9. Some of our models feature a sag indicator with both a blue line (RACE) and a red line (TRAIL). You can set the sag anywhere in this range to achieve a firmer or plusher overall feel depending on rider preference.

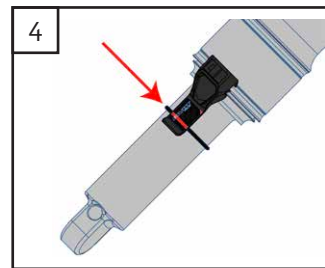
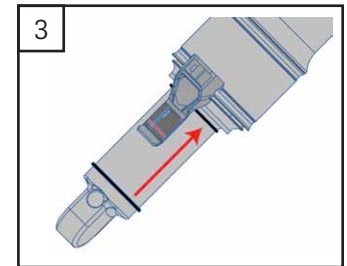
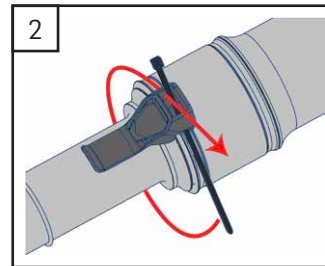
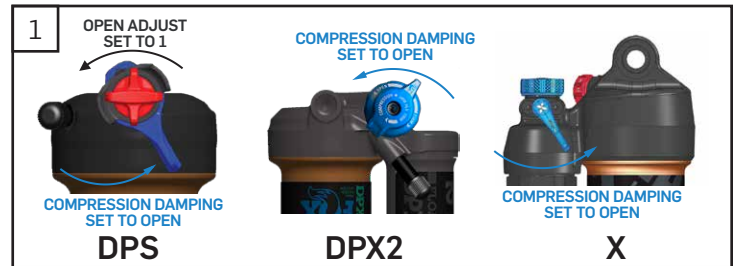

WARNING: Make sure the sag indicator does not contact the frame or linkage through the suspension cycle. Otherwise, the indicator may break while riding.

If there is no sag indicator on the shock, use the measurements listed below to determine sag. Different models and sizes of Pivot bikes use different length shocks and therefore require different sag settings.

Indicator A* Sag: 0.74" (18.8mm)*	Indicator B Sag: 0.65" (16.5mm)	Indicator C Sag: 0.49" (12.4mm)	Indicator D Sag: 0.55" (14.0mm)
Bikes: <ul style="list-style-type: none"> • Mach 5.7 • Mach 5: M-XL • Mach 6 Carbon* • Mach 6 Alloy* • Firebird* • Firebird 29* 	Bikes: <ul style="list-style-type: none"> • Switchblade (V1 & V2) • Shuttle • Mach 5.5 • Mach 5.7 Carbon • Mach 4: S-XL (2010 & Older) • Mach 5: XS-S • Mach 429 Alloy 	Bikes: <ul style="list-style-type: none"> • Mach 4: XXS-XS • Mach 4 Carbon SL 	Bikes: <ul style="list-style-type: none"> • Mach 4: S-XL (2011 & Newer) • Mach 429 Carbon • Mach 429 SL • Mach 429 Trail • Trail429

*Sag Measurement: 0.80" (20.3mm); set between the red line and the end of the indicator

Setting Rebound & Compression Adjustments on your Fork & Shock

Pivot counts the adjustment clicks for rebound and compression from fully open because this is where the settings are for sag setup. This saves time from closing the settings all the way and counting from closed. Another reason is it is easy to damage the shock or fork adjustments when turning the adjuster all the way in. It can feel like there is an "extra" 1/2 click that doesn't exist. This can break the adjustments and requiring service or repair. Fox suspension set up guides always count clicks from closed.

Setting Damping Adjustment on FOX Float DPS



Rebound Damping: Rebound setting is dependent on air pressure. For example, higher air pressures require slower rebound setting. The rebound setting is determined by the air pressure in the shock. We set rebound from the most open or fastest position, so start by turning the *red* rebound dial counterclockwise all the way out. Refer to the table on the right for the suggested rebound setting. The number in the chart refers to how many clicks clockwise from the open setting the rebound should be set. Fox suspension set up guides always show rebound setting counted from the closed position, so the table includes this as well in parentheses.

Refer to the table on the right for the suggested rebound setting. The number in the chart refers to how many clicks clockwise from the open setting the rebound should be set. Fox suspension set up guides always show rebound setting counted from the closed position, so the table includes this as well in parentheses.

Compression Damping: Because all dw-link® equipped Pivot bikes pedal so efficiently, we use the compression lever as a tuning tool for rider weight and compression support. All bikes can be run with the *blue* lever in full open and perform very well. On Float DPS shocks, this means the lever is turned towards the opposite side of the air valve. Lighter riders under 160lbs will generally run in the full open position most of the time. Riders in the 190lb+ range and more aggressive riders who like the feel of more mid-stroke support will generally prefer the middle setting. The firm setting is great for your ride to the trail, long fire road climbs, and smooth XC race courses where a more locked out feel is desired.

All Factory Series Float DPS shocks feature three additional options that affect the open setting via the *black* knob. This knob needs to be lifted slightly to turn to one of the three designated options. #1 is the most open, or least amount of compression damping, and #3 is the firmest (but still slightly less firm than the middle position of the *blue* lever). You can experiment with all of these options to find the setting that provides the best compression support and plush feel for your weight and riding style. Other than running in the full firm mode on rocky descents, all settings are designed to work well in a wide variety of terrain and rider weights.

Float DPS Shock	
Suggested Rebound Setting	
Air Pressure [psi]	Clicks from OPEN (Clicks from CLOSED)
<100	OPEN
100-120	3 (11)
120-140	4 (10)
140-160	5 (9)
160-180	6 (8)
180-200	7 (7)
200-220	8 (6)
220-240	9 (5)
240-260	10 (4)
260-280	11 (3)
280-300	CLOSED

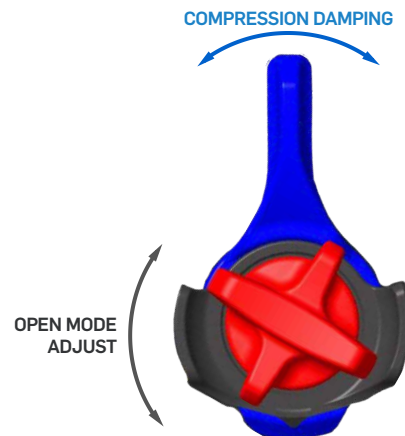

Setting Rebound & Compression Adjustments on your Fork & Shock

Pivot counts the adjustment clicks for rebound and compression from fully open because this is where the settings are for sag setup. This saves time from closing the settings all the way and counting from closed. Another reason is it is easy to damage the shock or fork adjustments when turning the adjuster all the way in. It can feel like there is an "extra" 1/2 click that doesn't exist. This can break the adjustments and requiring service or shock repair. Fox suspension set up guides always count clicks from closed.

Setting Damping Adjustment on FOX Float DPX2



Rebound Damping: Rebound setting is dependent on air pressure. For example, higher air pressures require slower rebound setting. The rebound setting is determined by the air pressure in the shock. We set rebound from the most open or fastest position, so

start by turning the *red* rebound dial counterclockwise all the way out. Refer to the table at the right for the suggested rebound setting. The number in the chart refers to how many clicks clockwise from the open setting the rebound should be set. Fox sets rebound from the closed position, so the table includes this in parentheses.

Compression Damping: On Float DPX2 shocks, the compression damping is in the fully open position when the lever is turned up, towards the top tube. Lighter riders under 180lbs will generally run in the full open position most of the time. Riders in the 180lb+ range and more aggressive riders who like the feel of more mid-stroke support will generally prefer the middle setting. As with the other shocks, the firm setting is best suited for long fire road climbs and smooth XC courses.

The Factory Series Float DPX2 features a 3mm screw inside the top of the *blue* compression damping lever, which can be used to fine tune the open mode of the compression damping using a 3mm hex wrench. This screw offers 10 additional fine tune adjustment settings to the open mode. Turning the screw clockwise will increase low speed compression damping. Turning the screw counter-clockwise will decrease low speed compression damping. You can experiment with all of these options to find the setting that provides the best compression support and plush feel for your weight and riding style. For a rider between 160-170lbs., we like to start at 8 clicks in from full open as a good baseline setting. For riders about 190 lbs., we recommend 1-2 clicks out from full closed. Heavier riders and more aggressive riders over 185 lbs. will want to run the lever in the middle setting. The 3mm adjuster only affects the compression adjustment in the open setting. The middle lever setting is about the equivalent of having 3 additional (firmer) compression clicks on the 3mm adjuster.

Float DPX2 Shock	
Suggested Rebound Setting	
Air Pressure [psi]	Clicks from OPEN (Clicks from CLOSED)
<120	3 (11)
120-140	4 (10)
140-160	5 (9)
160-180	6 (8)
180-200	7 (7)
200-220	9 (5)
220-240	10 (4)
240-260	12 (2)
260-280	13 (1)
280-300	CLOSED



Setting Rebound & Compression Adjustments on your Fork & Shock

Pivot counts the adjustment clicks for rebound and compression from fully open because this is where the settings are for sag setup. This saves time from closing the settings all the way and counting from closed. Another reason is it is easy to damage the shock or fork adjustments when turning the adjuster all the way in. It can feel like there is an "extra" 1/2 click that doesn't exist. This can break the adjustments and requiring service or shock repair. Fox suspension set up guides always count clicks from closed.

Setting Damping Adjustment on FOX Float X



Rebound Damping: Rebound setting is dependent on air pressure. For example, higher air pressures require slower rebound setting. The rebound setting is determined by the air pressure in the shock. We set rebound from the most open or fastest position, so start by turning the

red rebound dial counterclockwise all the way out. Refer to the table to the right for the suggested rebound setting. The number in the chart refers to how many clicks clockwise from the open setting the rebound should be set. Fox sets rebound from the closed position, so that has been provided in the table in parentheses.

Compression Damping: Float X shocks feature a two position lever allows for on-the-fly adjustment between fully open and firm for climbing. As with the other shocks, the firm setting is best suited for long fire road climbs and smooth XC courses.

The Factory Series Float X features a blue low speed compression adjustment knob, which can be used to fine tune the open mode of the compression damping. This knob offers 10 additional fine tune adjustment settings to the open mode. Turning the knob clockwise will increase low speed compression damping. Turning the screw counterclockwise will decrease low speed compression damping. You can experiment with all of these options to find the setting that provides the best compression support and plush feel for your weight and riding style. For a rider close to 100lbs. we recommend having the compression fully open, by having the knob turned fully counter-clockwise. For riders 200lbs we like to start at 3 clicks in from full closed as a good baseline setting. If the rider's weight is less than 200lbs., open up compression dampening 1 click counter-clockwise for every 10lbs. less. For every 10lbs over 200lbs we recommend increasing compression damping by 1 click clockwise.

Float X Shock	
Suggested Rebound Setting	
Air Pressure [psi]	Clicks from OPEN (Clicks from CLOSED)
<120	1 (9)
120-140	2 (8)
140-160	3 (7)
160-180	4 (6)
180-200	5 (5)
200-220	6 (4)
220-240	7 (3)
240-260	8 (2)
260-280	9 (1)
280-300	CLOSED



2. Fox Float X2 Air

Setting Sag on FOX Float X2

Start by setting sag using the same process as the shocks on page 2. The sag indicator on this shock is located on the oil reservoir rather than attached to the air sleeve. If there is no sag indicator on the oil reservoir use the measurements listed below to determine sag. Different models and sizes of Pivot bikes use different length shocks and therefore require different sag settings. The bike models for each sag setting are listed under the respective diagrams. The Phoenix 29 shock does not use the sag indicator sticker. Instead, sag should be set by lining up the the o-ring with bottom of the reservoir.

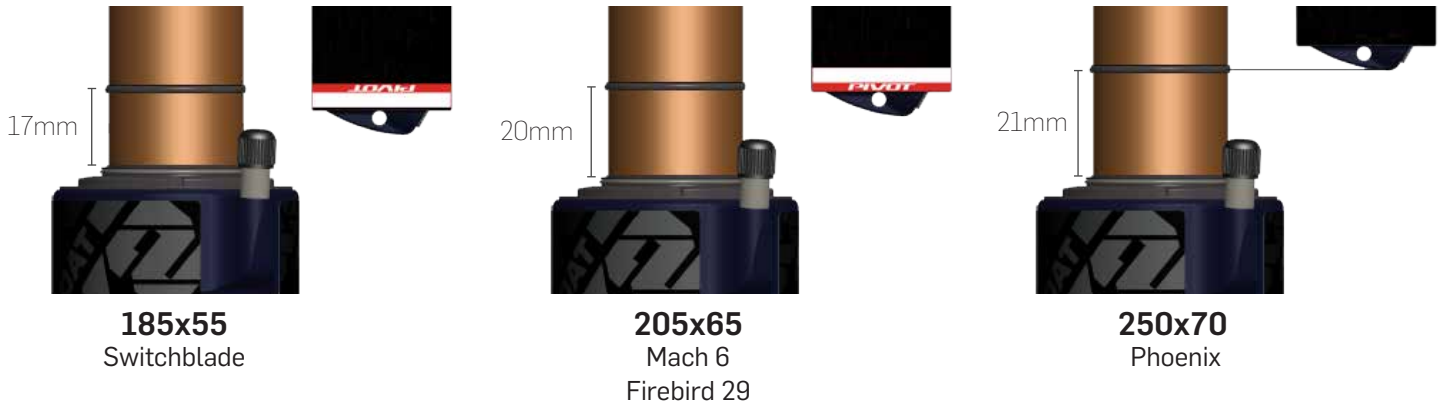

Damping Adjustment on FOX Float X2

The X2 air shock has tuning options well beyond the scope of what we can cover here. Not only can the shock be tuned through the use of the HSC, LSC, HSR, and LSR knobs, but it can also be tuned via the amount of air pressure in the shock and the addition or removal of air volume spacers to change the spring curve characteristics. We have settled on an air spring curve that has proven to be optimized for a wide range of riders from a sport level to our World Cup DH team, so changing the Pivot factory air spring curve characteristics is not really necessary.

We recommend 30% sag on the Float X2 Air. Based on this sag setting you can record your air pressure and use FOX's tuning chart copied on the next page to set your *High Speed Compression* damping (HSC), *Low Speed Compression* damping (LSC), *High Speed Rebound* damping (HSR), and *Low Speed Rebound* damping (LSR). These settings are also applicable to Performance series Float X2 air shocks that feature only the LSC and LSR adjustments. The numbers in the chart refers to how many clicks clockwise from the open setting the dials should be set. Fox sets up shocks from the closed position, so that has been provided in parentheses.

The diagram to the right shows the locations of each adjustment knob on the MY2021 X2 shock.

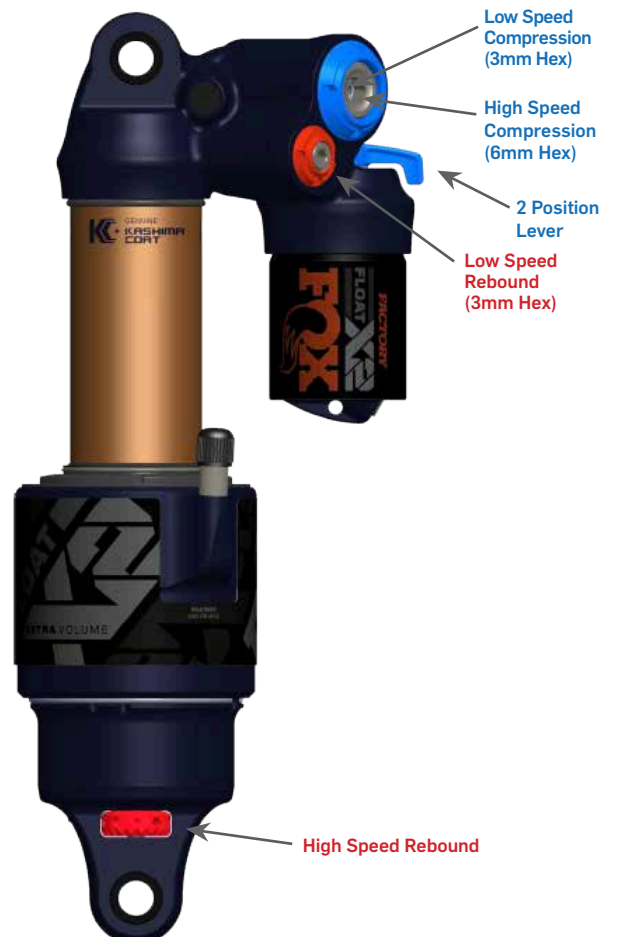

Rebound & Compression Damping Settings Table for FOX Float X2

Suggested Settings MY2021 FOX FLOAT X2				
Air Spring Pressure	Baseline LSR (3mm hex)	Baseline HSR (2mm hex)	Baseline LSC (3mm hex)	Baseline HSC (6mm hex)
	Clicks from OPEN (Clicks from CLOSED)			
90	2-4 (16-18)	Open-1 (7-8)	Open-2 (16-18)	Open-1 (7-8)
100	3-5 (15-17)	Open-1 (7-8)	Open-2 (16-18)	Open-1 (7-8)
110	4-6 (14-16)	1-2 (6-7)	1-3 (15-17)	Open-1 (7-8)
120	5-7 (13-15)	1-2 (6-7)	1-3 (15-17)	Open-1 (7-8)
130	6-8 (12-14)	2-3 (5-6)	2-4 (14-16)	1-2 (6-7)
140	7-9 (11-13)	2-3 (5-6)	2-4 (14-16)	1-2 (6-7)
150	8-10 (10-12)	2-3 (5-6)	3-5 (13-15)	1-2 (6-7)
160	9-11 (9-11)	3-4 (4-5)	3-5 (13-15)	1-2 (6-7)
170	10-12 (8-10)	3-4 (4-5)	4-6 (12-14)	2-3 (5-6)
180	11-13 (7-9)	3-4 (4-5)	5-7 (11-13)	2-3 (5-6)
190	11-13 (7-9)	4-5 (3-4)	6-8 (10-12)	2-3 (5-6)
200	12-14 (6-8)	4-5 (3-4)	7-9 (9-11)	3-4 (4-5)
210	12-14 (6-8)	4-5 (3-4)	8-10 (8-10)	3-4 (4-5)
220	13-15 (5-7)	5-6 (2-3)	9-11 (7-9)	3-4 (4-5)
230	14-16 (4-6)	5-6 (2-3)	10-12 (6-8)	3-4 (4-5)
240	15-17 (3-5)	5-6 (2-3)	11-13 (5-7)	4-5 (3-4)
250	16-18 (2-4)	5-6 (2-3)	12-14 (4-6)	4-5 (3-4)
260	16-18 (2-4)	6-7 (1-2)	14-16 (2-4)	4-5 (3-4)
270	17-19 (1-3)	6-7 (1-2)	14-16 (2-4)	4-5 (3-4)
280	17-19 (1-3)	6-7 (1-2)	14-16 (2-4)	5-6 (2-3)
290	17-19 (1-3)	7-8 (0-1)	15-17 (1-3)	5-6 (2-3)
300	18-19 (1-2)	7-8 (0-1)	15-17 (1-3)	5-6 (2-3)

Setting Damping Adjustment on FOX Float X2

In general, we are running the rebound settings at the slower end of the range provided at each pressure and the compression settings at the lighter end of the provided range. For example, if you are running 200psi in the shock, the range for LSR is listed as 12-14 clicks in from open; We recommend starting at 14. For HSR the range is 4-5 clicks in from open; We recommend starting at 5. On the compression side for LSC, at 200psi in the shock, the range is 7-9 clicks in from open; We recommend starting at 7 clicks in. For HSC the range is 3-4 clicks in from open; We recommend starting at 3. If you follow this same process for the pressure that you are running then you'll have an excellent starting set up that may not require any further adjustment. The two position lever allows for on-the-fly adjustment between fully open and firm for climbing.

For further detail, FOX provides a complete tuning guide for the Float X2 Air shock on their website at www.ridefox.com

3. FOX Coil Shocks

Setting Sag on FOX Coil Shock

1. To set sag on a coil shock you will want to have a friend and a tape measure that has millimeters on it. You will need to measure the eye-to-eye distance on your bike. This is the distance between the two shock mounting bolts. On the Mach 6 or Firebird 29 this distance is 205mm. The correct amount of sag for this is 18-19mm. When you are seated on the bike with all your weight after completing the steps for sag setup the distance from shock bolt to shock bolt should measure 187-188mm.
2. Always set sag with the blue compression lever to the open position.
3. If your shock has additional compression and rebound adjustments ensure they are adjusted to be fully open, compression in the softest setting, and rebound to its fastest setting.
4. After installing the coil spring, set the preload adjuster to where it just contacts the coil spring applying a small amount of tension. On Fox shocks this should be about 8 clicks of the preload adjuster.
5. Find a level surface and something to steady yourself while mounted on the bike so you can be on the pedals in a seated position. It may be easier to have a partner hold your bike steady from the front by the handlebars while you are in your riding position.
6. While standing on the pedals, sit down hard into the saddle to cycle the suspension well into the stroke. This will ensure the bike comes to a rest at the natural sag setting with the rider in the saddle.
7. While in the saddle and not moving or unweighting the shock, have your friend measure the eye-to-eye distance. Subtract this number from the beginning eye-to-eye to get your sag measurement.
8. If the sag measurement is less than the recommended sag of 18-19mm you will need to change out the spring for a lower spring rate.
9. If the sag measurement is more than the recommended 18-19mm then you can turn the spring preload adjuster up to 26 clicks from where it just contacted the spring. If you cannot achieve the recommended sag with 26 clicks you will need to change the spring out for a higher spring rate.
10. Once you have achieved proper sag follow the recommended compression and rebound settings to complete your suspension setup.



Spec rates should match the average rider for the frame size but some riders may need a lighter or heavier spring to achieve the recommended 30% sag. Listed below are the recommended spring rates based on rider weight as well as coil length and spring stroke specifications for the spring required to run on FOX and Marzocchi coil-over shocks used on the Mach 6.

SPRING RATE	TOTAL LENGTH	SPRING TRAVEL	I.D.	RIDER WEIGHT
350lb.	4.85"	2.65"	1.385"	< 130lb.(59kg)
400lb.	5.14"	2.65"	1.385"	130lb.(59kg) - 150lb.(68kg)
450lb.	5.11"	2.65"	1.385"	150lb.(68kg) - 170lb.(77kg)
500lb.	5.32"	2.65"	1.385"	170lb.(77kg) - 190lb.(86kg)
550lb.	5.38"	2.65"	1.385"	190lb.(86kg) - 210lb. (95kg)
600lb.	5.47"	2.65"	1.385"	210lb. (95kg)- 230lb. (104kg)
650lb	5.6"	2.65"	1.385"	> 230lb. (104kg)

Damping Adjustment on FOX DHX2

The DHX2 shock has tuning options well beyond the scope of what we can cover here. Not only can the shock be tuned through the use of the HSC, LSC, HSR, and LSR knobs, but it can also run different spring rates.

We recommend 30% sag on the DHX2. Based on your spring rate to achieve proper sag, refer to FOX's tuning chart copied below to set your High Speed Compression damping (HSC), Low Speed Compression damping (LSC), High Speed Rebound damping (HSR), and Low Speed Rebound damping (LSR). The numbers in the chart refers to how many clicks clockwise from the open setting the dials should be set. Fox sets up shocks from the closed position, so that has been provided in parentheses.

The diagram to the right shows the locations of each adjustment knob on the MY2021 DHX2 shock.

Suggested Settings / MY2021 FOX DHX2				
Spring Rate	Baseline LSR (3mm hex)	Baseline HSR (2mm hex)	Baseline LSC (3mm hex)	Baseline HSC (6mm hex)
	Clicks from OPEN (Clicks from CLOSED)			
200	2-4 (16-18)	Open-1 (7-8)	Open-2 (16-18)	Open-1 (7-8)
225	3-5 (15-17)	Open-1 (7-8)	Open-2 (16-18)	Open-1 (7-8)
250	4-6 (14-16)	1-2 (6-7)	1-3 (15-17)	Open-1 (7-8)
275	5-7 (13-15)	1-2 (6-7)	1-3 (15-17)	Open-1 (7-8)
300	6-8 (12-14)	2-3 (5-6)	2-4 (14-16)	1-2 (6-7)
325	7-9 (11-13)	2-3 (5-6)	2-4 (14-16)	1-2 (6-7)
350	8-10 (10-12)	2-3 (5-6)	3-5 (13-15)	1-2 (6-7)
375	9-11 (9-11)	3-4 (4-5)	3-5 (13-15)	1-2 (6-7)
400	10-12 (8-10)	3-4 (4-5)	4-6 (12-14)	2-3 (5-6)
425	11-13 (7-9)	3-4 (4-5)	5-7 (11-13)	2-3 (5-6)
450	11-13 (7-9)	4-5 (3-4)	6-8 (10-12)	2-3 (5-6)
475	12-14 (6-8)	4-5 (3-4)	7-9 (9-11)	3-4 (4-5)
500	12-14 (6-8)	4-5 (3-4)	8-10 (8-10)	3-4 (4-5)
525	13-15 (5-7)	5-6 (2-3)	9-11 (7-9)	3-4 (4-5)
550	14-16 (4-6)	5-6 (2-3)	10-12 (6-8)	3-4 (4-5)
575	15-17 (3-5)	5-6 (2-3)	11-13 (5-7)	4-5 (3-4)
600	16-18 (2-4)	5-6 (2-3)	12-14 (4-6)	4-5 (3-4)
625	16-18 (2-4)	6-7 (1-2)	14-16 (2-4)	4-5 (3-4)
650	17-19 (1-3)	6-7 (1-2)	14-16 (2-4)	4-5 (3-4)
675	17-19 (1-3)	6-7 (1-2)	14-16 (2-4)	5-6 (2-3)
700	17-19 (1-3)	7-8 (0-1)	15-17 (1-3)	5-6 (2-3)
725	18-19 (1-2)	7-8 (0-1)	15-17 (1-3)	5-6 (2-3)



3. FOX Float Air Fork:

Setting Sag on FOX Float Air Fork

Proper sag for the fork is 15 - 20% of the full fork travel. The table below provides FOX's recommended starting point for fork air pressure to achieve proper sag. However, through Pivot's testing, we have found that for some riders, the recommended is too high and limits the ability to achieve full fork travel. You may need to lower the pressure if full travel is not reached. In general, we find that riders are running 2-3 pressure settings below the air pressure recommended for their rider weight.

For example, based on the chart below a 200lbs. rider with a 2021 Fox Float 36 would want to run 94 psi in their fork. Our recommendation for most riders at this weight is to run between 82-86 psi., by moving two or three rows up the chart. Based on our research and feedback we have found that running two or three rows up the chart will give most riders in most conditions a more balanced feeling suspension. Once you have settled on your air pressure follow the corresponding damping setting for your model fork.

RIDER WEIGHT	32 FLOAT	34 FLOAT	36 FLOAT	38 FLOAT	40/49 FLOAT
120-130 [lbs]	65 [psi] 4.5 [bar]	58 [psi] 4 [bar]	66 [psi] 4.6 [bar]	72 [psi] 5.0 [bar]	52 [psi] 3.6 [bar]
130-140 [lbs]	70 [psi] 4.8 [bar]	63 [psi] 4.3 [bar]	70 [psi] 4.8 [bar]	76 [psi] 5.2 [bar]	58 [psi] 4.0 [bar]
140-150 [lbs]	74 [psi] 5.1 [bar]	68 [psi] 4.7 [bar]	74 [psi] 5.1 [bar]	80 [psi] 5.5 [bar]	64 [psi] 4.4 [bar]
150-160 [lbs]	80 [psi] 5.5 [bar]	72 [psi] 5.0 [bar]	78 [psi] 5.4 [bar]	84 [psi] 5.8 [bar]	68 [psi] 4.7 [bar]
160-170 [lbs]	85 [psi] 5.9 [bar]	77 [psi] 5.3 [bar]	82 [psi] 5.7 [bar]	89 [psi] 6.1 [bar]	72 [psi] 5.0 [bar]
170-180 [lbs]	90 [psi] 6.2 [bar]	82 [psi] 5.7 [bar]	86 [psi] 5.9 [bar]	93 [psi] 6.4 [bar]	76 [psi] 5.2 [bar]
180-190 [lbs]	96 [psi] 6.6 [bar]	86 [psi] 5.9 [bar]	89 [psi] 6.1 [bar]	97 [psi] 6.7 [bar]	80 [psi] 5.5 [bar]
190-200 [lbs]	101 [psi] 7.0 [bar]	91 [psi] 6.3 [bar]	94 [psi] 6.5 [bar]	102 [psi] 7.0 [bar]	84 [psi] 5.8 [bar]
200-210 [lbs]	106 [psi] 7.3 [bar]	96 [psi] 6.6 [bar]	99 [psi] 6.8 [bar]	106 [psi] 7.3 [bar]	87 [psi] 6.0 [bar]
210-220 [lbs]	111 [psi] 7.7 [bar]	100 [psi] 6.9 [bar]	105 [psi] 7.2 [bar]	110 [psi] 7.6 [bar]	90 [psi] 6.2 [bar]
220-230 [lbs]	117 [psi] 8.1 [bar]	105 [psi] 7.2 [bar]	109 [psi] 7.5 [bar]	114 [psi] 7.9 [bar]	94 [psi] / 6.5 [bar]
230-240 [lbs]	122 [psi] 8.4 [bar]	110 [psi] 7.6 [bar]	113 [psi] 7.8 [bar]	119 [psi] 8.2 [bar]	97 [psi] 6.7 [bar]
240-250 [lbs]	126 [psi] 8.7 [bar]	114 [psi] 7.9 [bar]	117 [psi] 8.1 [bar]	123 [psi] 8.5 [bar]	101 [psi] 7.0 [bar]

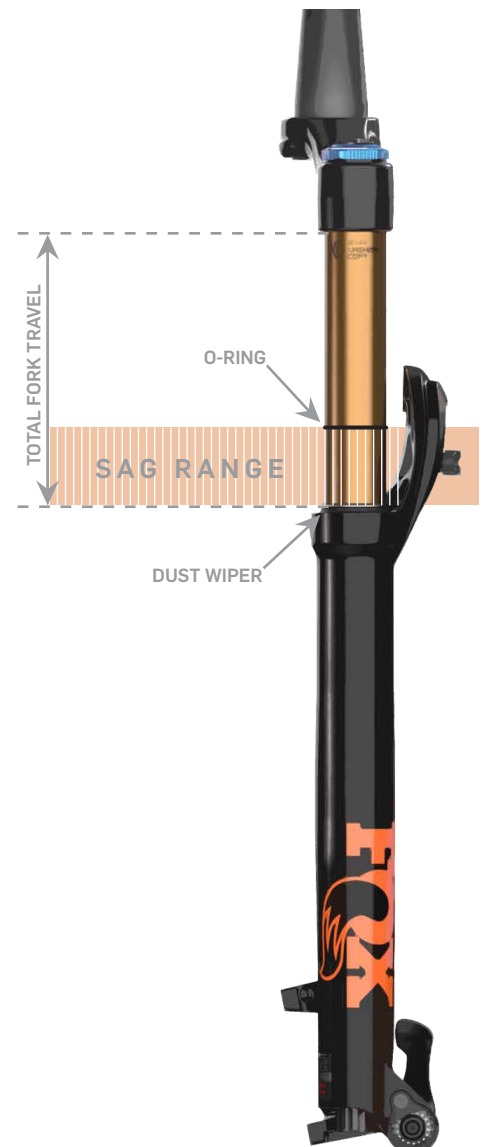

Setting FIT4 Damping Adjustment on FOX Float Air Fork

Rebound Damping: This adjustment is a *red* knob found on the bottom of the drive side fork leg. We set rebound from the most open or fastest position. Refer to the table for the suggested rebound setting. The number in the chart refers to how many clicks clockwise from the open setting the rebound should be set. Fox sets rebound from the closed position, so that has been provided in parentheses.

Compression Damping: The Fit 4 damper features a *blue* 3 position compression adjustment lever. These settings are open, medium, and firm. The black inner dial adjusts the low speed compression damping that affects the firmness of the suspension (compression damping) in the fully open position. We set compression from the most open or fastest position, so start by turning the black compression inner dial counterclockwise all the way out. Turn black dial clockwise in 2-8 clicks in (depending on rider weight). Most riders should feel comfortable with 5 clicks in as a starting point. A rider under 120lbs would start with 2 clicks in.

FIT4 DAMPER REBOUND SETTINGS		
RIDER WEIGHT	32-AX & 32-SC	32/34 36/38
	Clicks from OPEN (Clicks from CLOSED)	
120-130 [lbs]	2 (12)	Open (14)
130-140 [lbs]	3 (11)	1 (13)
140-150 [lbs]	4 (10)	2 (12)
150-160 [lbs]	4 (10)	3 (11)
160-170 [lbs]	5 (9)	5 (9)
170-180 [lbs]	6 (8)	6 (8)
180-190 [lbs]	6 (8)	7 (7)
190-200 [lbs]	7 (7)	8 (6)
200-210 [lbs]	8 (6)	9 (5)
210-220 [lbs]	10 (4)	10 (4)
220-230 [lbs]	11 (3)	11 (3)
230-240 [lbs]	12 (2)	12 (2)
240-250 [lbs]	13 (1)	13 (1)



FIT4 Compression Knob



Rebound Adjustment

Setting GRIP Damping Adjustment on FOX Float Air Fork

Rebound Damping: This adjustment is a *red* knob found on the bottom of the drive side fork leg. We set rebound from the most open or fastest position. Refer to the table for the suggested rebound setting. The number in the chart refers to how many clicks clockwise from the open setting the rebound should be set. Fox sets rebound from the closed position, so that has been provided in parentheses.

Compression Damping: We always start with the lever in the full open position. Most riders will not need to make any changes from this position. However, if you do need more compression support, the lever will provide a low speed compression adjustment until the lever is turned halfway. The second half of the lever adjustment affects the high speed compression circuit. Of course, fully closed provides a nearly locked out feel for climbing.

GRIP DAMPER REBOUND SETTINGS	
RIDER WEIGHT	SUGGESTED SETTING
	Clicks from OPEN (Clicks from CLOSED)
120-130 [lbs]	2 (21)
130-140 [lbs]	3 (20)
140-150 [lbs]	4 (19)
150-160 [lbs]	5 (18)
160-170 [lbs]	6 (17)
170-180 [lbs]	7 (16)
180-190 [lbs]	8 (15)
190-200 [lbs]	9 (14)
200-210 [lbs]	10 (13)
210-220 [lbs]	11 (12)
220-230 [lbs]	12 (11)
230-240 [lbs]	13 (10)
240-250 [lbs]	14 (9)



GRIP Compression Knob

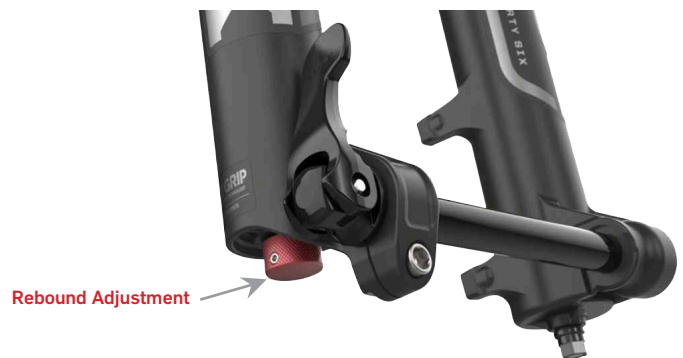

Setting GRIP2 Damping Adjustment on FOX Float Air Fork

Rebound Damping: The Grip2 dampers have both low speed and high speed rebound damping. Both knobs are located on the bottom of the driveside fork leg. We set rebound from the most open or fastest position. Refer to the table for the suggested rebound setting. The number in the chart refers to how many clicks clockwise from the open setting the rebound should be set. Fox sets rebound from the closed position, so that has been provided in parentheses.

Compression Damping: The Grip2 damper has dials for both low speed and high speed compression damping. The compression damping is controlled by two dials on the top of the right fork leg; the blue outer dial adjusts high speed compression damping and the black inner dial adjusts low speed compression damping. We set compression from the open or fastest position, so start by turning the both the blue and black compression dials counter-clockwise all the way out. Turn blue dial clockwise 2 clicks in and turn the black dial 5 clicks in.

GRIP2 DAMPER REBOUND SETTINGS		
RIDER WEIGHT	34/36/38	40/49
	LSR / HSR	LSR / HSR
	Clicks from OPEN (Clicks from CLOSED)	
120-130 [lbs]	3 / Open (12 / 10)	5 / Open (10 / 10)
130-140 [lbs]	4 / Open (11 / 10)	6 / 1 (9 / 9)
140-150 [lbs]	5 / 1 (10 / 9)	7 / 2 (8 / 8)
150-160 [lbs]	6 / 2 (9 / 8)	7 / 2 (8 / 8)
160-170 [lbs]	7 / 3 (8 / 7)	8 / 3 (7 / 7)
170-180 [lbs]	8 / 4 (7 / 6)	8 / 3 (7 / 7)
180-190 [lbs]	8 / 4 (7 / 6)	9 / 4 (6 / 6)
190-200 [lbs]	9 / 5 (6 / 5)	10 / 5 (5 / 5)
200-210 [lbs]	9 / 5 (6 / 5)	10 / 5 (5 / 5)
210-220 [lbs]	10 / 6 (5 / 4)	11 / 6 (4 / 4)
220-230 [lbs]	11 / 7 (4 / 3)	12 / 7 (3 / 3)
230-240 [lbs]	11 / 7 (4 / 3)	12 / 7 (3 / 3)
240-250 [lbs]	12 / 8 (3 / 2)	13 / 8 (2 / 2)



GRIP2
Compression
Knob

