

# CABINEO ENGAGEMENT INSTRUCTIONS

(DO NOT ENGAGE CABINEOS PRIOR TO ATTACHING PANELS)

**STEP 1: Insert provided 5mm allen-key into cabineo.**

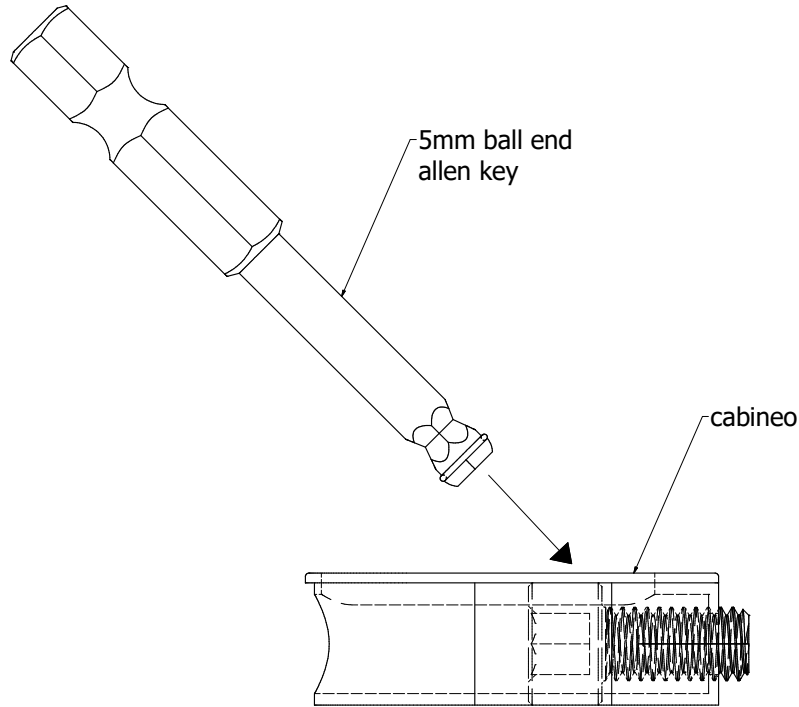

**STEP 2: Tighten cabineo by turning bolt clock-wise.  
USE CARE NOT TO OVER TIGHTEN**

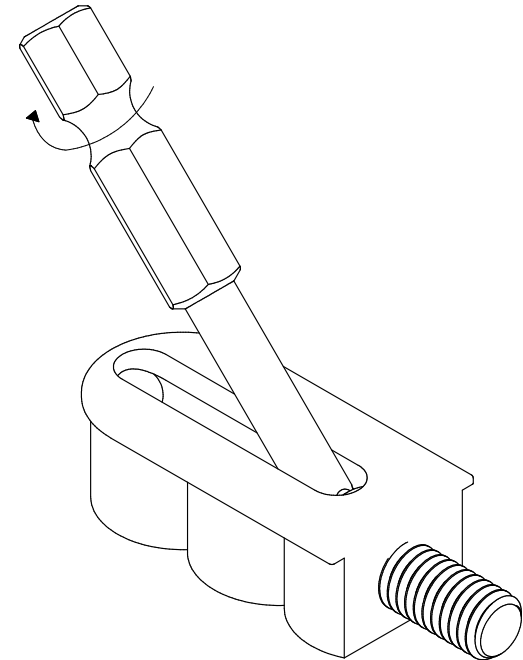

DRAWN Daniell	DATE 4/20/2023	This document and all contained information is the property of Modern Stone Equipment (MSE), neither type nor quantity shall be reproduced or transmitted in any form or by any means, electronic, mechanical, photocopying, recording, or by any information storage and retrieval system, without the prior written permission of Modern Stone Equipment. THIS DRAWING AND ANY INFORMATION CONTAINED HEREIN IS NOT TO BE USED IN ANY MANNER AGAINST THE INTERESTS OF Modern Stone Equipment AND WILL BE RETURNED ON DEMAND.	
CHECKED		MSE	
QA			
MFG			
APPROVED			
MODERN STORE		SIZE D	REV
EQUIPMENT		SCALE 5	CMFG4242_4waypegboard_v1Xplod
		SHEET 1 OF 3	

**STEP 1:** Attach casters (A) (x4) to caster plate (B) using the provided bolts (C) (x16) and T-Nuts (D) (x16). Tighten bolts until snug.

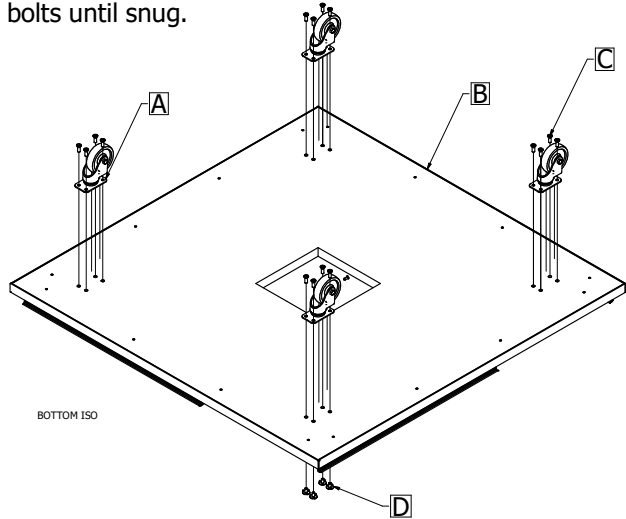

**STEP 2:** After casters are attached, apply the kick (E) to the caster plate (B) by engaging the pre-attached cabineos (F). Use care not to overtighten cabineos.

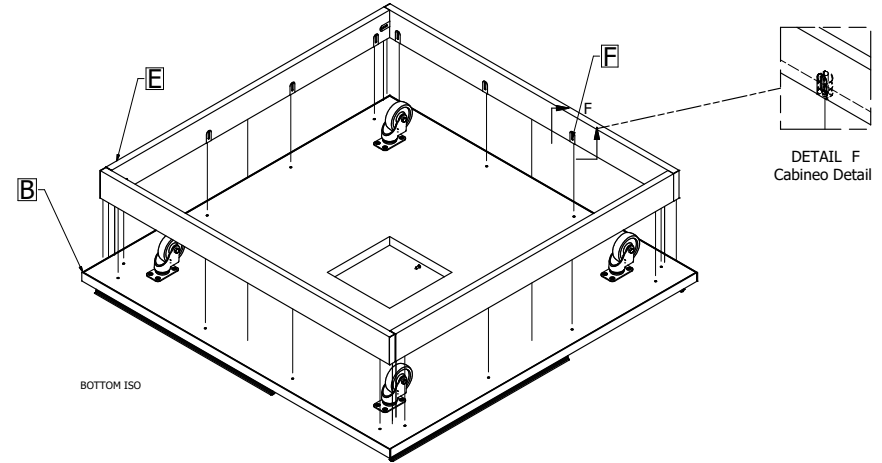

**STEP 3:** Once kick is secured, carefully flip the assembled plate (B) over with the casters down and insert the 24 provided dowels (G) into the 8mm holes.

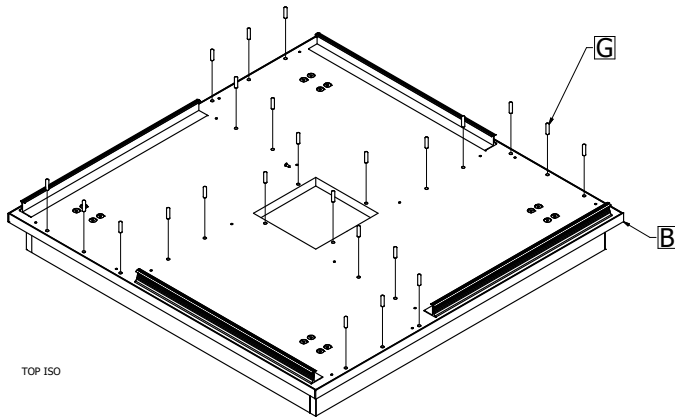

**STEP 4:** Assemble "L" sub-assemblies (H) (x4) using pre-installed cabineos (F). Use care not to over tighten cabineos. Note location of 5/8" chase hole for proper panel orientation. Cabineos should face adjoining panel as shown.

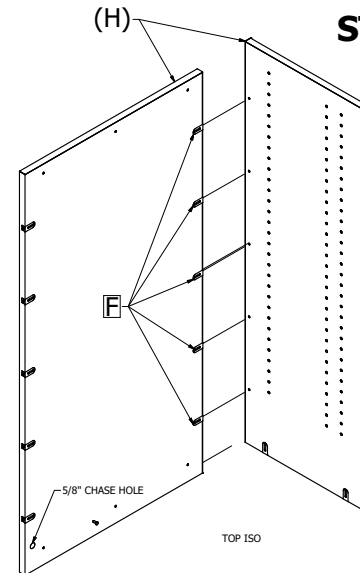

DRAWN Daniell	DATE 4/20/2023	<small>This document and all contained information is the property of Modern Stone Equipment (MSE), neither this drawing, nor any part hereof, nor any component illustrated herein may be reproduced in whole or in part, without the prior written authority of Modern Stone Equipment. THIS DRAWING AND ANY INFORMATION ON THIS DRAWING, INCLUDING THIS NOTICE, SHALL BE RETURNED TO THE INTERESTS OF Modern Stone Equipment AND WILL BE RETURNED ON DEMAND.</small>
CHECKED	DATE	
QA		
MFG		
APPROVED		
<b>MODERN STORE EQUIPMENT</b>		SIZE D CMFG4242 4waypegboard_v1x1p10d SCALE 1 / 6 SHEET 2 OF 3

**STEP 5:** Attach assembled "L" panels (H) to the previously installed dowels. Secure panel to bottom plate using the pre-installed cabineos (F) (4x).

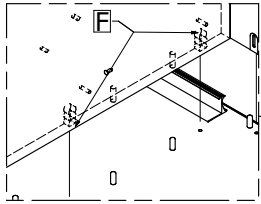

DETAIL C  
SCALE 0.27 : 1

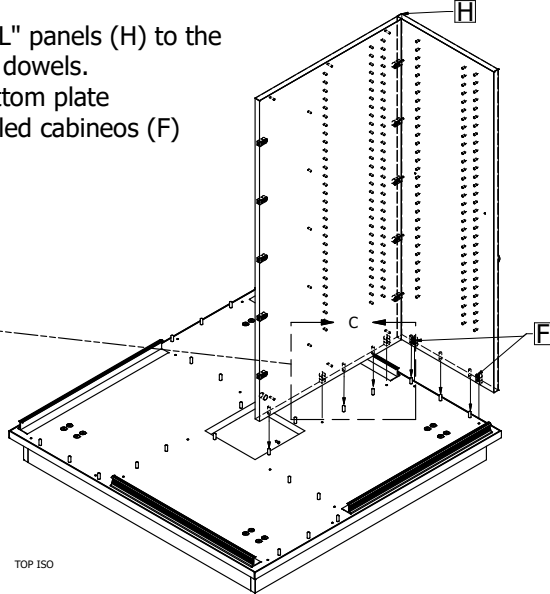

TOP ISO

**STEP 6:** Engage all cabineos (F) along edge of one "L" panel into the back of the adjoining "L" panel. Repeat for each "L" panel. Install pegboard panels (I) by sliding into place and attaching 1-1/4" wood screws (5x) through the back of the "L" panels (H), and (1x) through the front (see note). Repeat for remaining 3 panels. Use provided stickers to cover the front screw locations.

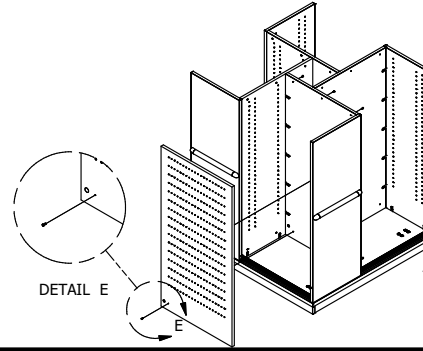

DETAIL E

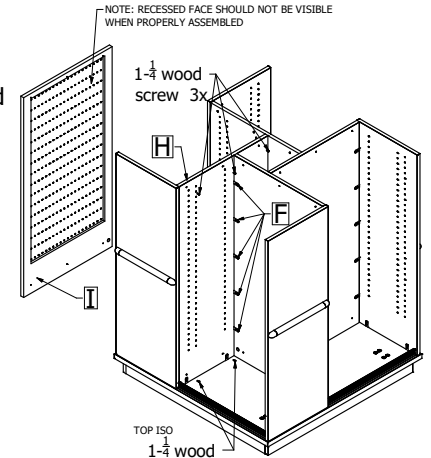

NOTE: RECESSED FACE SHOULD NOT BE VISIBLE WHEN PROPERLY ASSEMBLED

TOP ISO  
1-1/4" wood screw 3x

NOTE: 1 of the 3 screws is applied to the face of the panel on bottom left corner (see Detail "E")

**STEP 7:** After pegboard panels are installed, insert 4 alignment dowels into top cap (J) and install with pegs down.

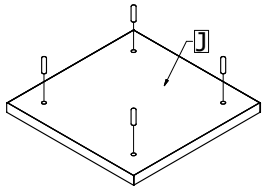

BOTTOM ISO OF TOP CAP

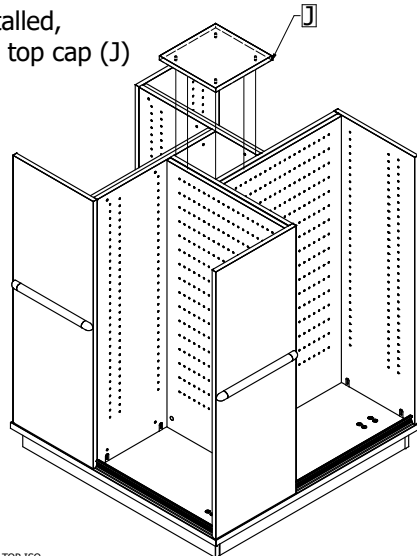

TOP ISO

**STEP 8:** Determine desired positions of shelf (L) and/or dump-bin (M) and install steel shelf pins (K). Install on pins. (Can be left open for hanging merchandise)

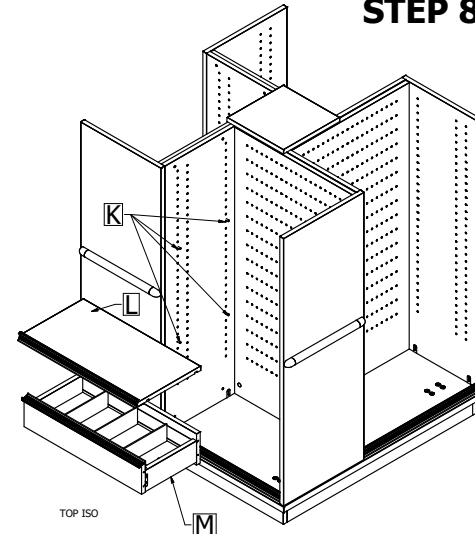

TOP ISO

**Step 9:** Show off your awesome assembly skills to colleagues!

DRAWN Daniell	4/20/2023	This document and all contained information is the property of Modern Store Equipment (MSE), neither this drawing, nor any other component illustrated herein may be reproduced or used in any way without the prior written authority of Modern Store Equipment. THIS DRAWING AND ANY INFORMATION CONTAINED HEREIN IS NOT TO BE USED IN ANY MANNER AGAINST THE INTERESTS OF Modern Store Equipment AND WILL BE RETURNED ON DEMAND.	
CHECKED			
QA			
MFG			
APPROVED			
<b>MODERN STORE EQUIPMENT</b>		SIZE D CMFG4242 4waypegboard_v1x1p0d SCALE 1 / 7.5 SHEET 3 OF 3	REV 1