



# Unisub Name Badges

Unisub Sublimation Tip Sheet

## MATERIALS NEEDED:

- Unisub Bare Name Badge
- Printed Transfer and Scissors
- Sublimation Printer (RIP Printing Software)
- Small Swing Away Heat Press set to 385° F (Heat Gloves and Heat Tape)
- Blowout Paper
- Cloth for Cleaning and All-Purpose Cleaner



## INSTRUCTIONS

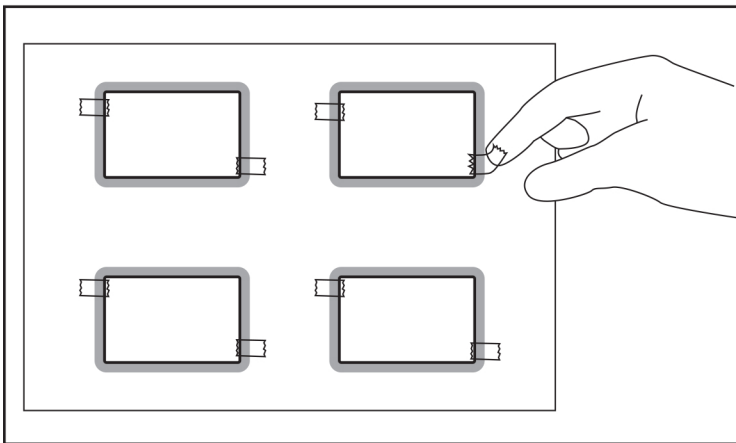

**Step 1:** First, clean the name badge. Next, line it up and center on transfer. Tape to the transfer.

Product	Time	With Jig
Aluminum	45-55 seconds	1:20
FRP (fiberglass reinforced plastic)	0:55-1:05	1:10-1:25
THB (tempered hard-board)	45-55 seconds	--

**Step 2:** With bare sides facing up, press name badges at 385° F following the times for each surface in the chart above. Time may vary based on equipment. Increase time if pressing more than one badge at a time.

**Step 3:** Remove the transfer, let cool, and attach magnetic backing or pin (not included, see your distributor for backing options).

**Extra Tip:** To learn about using jigs, see our jig tip sheet, and ask your distributor for a custom made jig.