

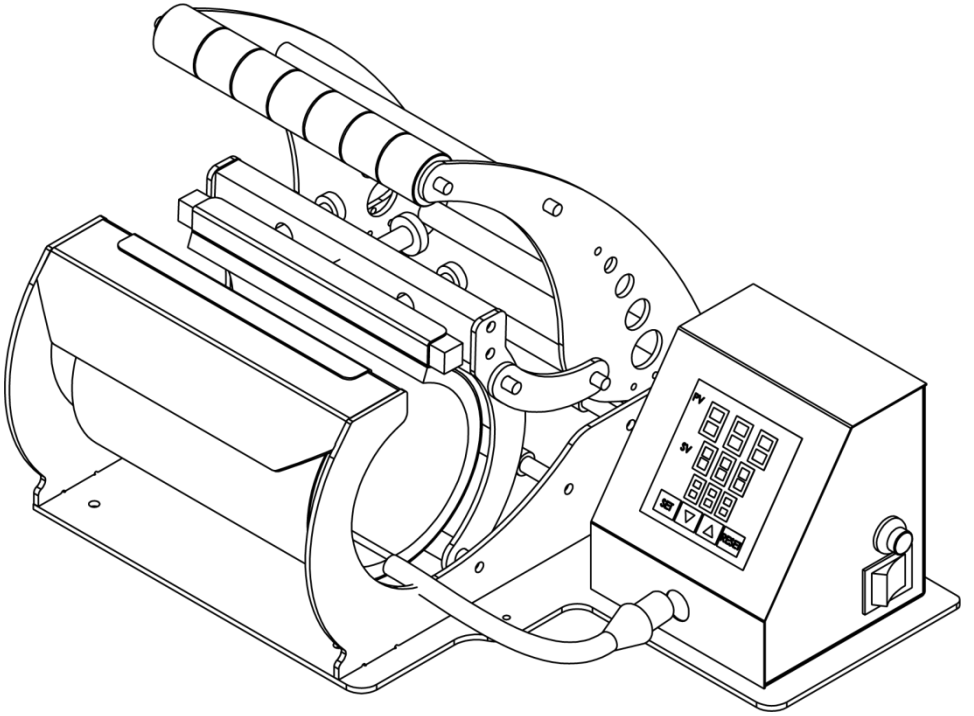

11oz Mug Heat Press Machine

USER MANUAL



Before Using

- 1. Please keep out of the reach of children and read the whole instruction manual carefully.**
2. Ensure that the quality of the power outlet used is up to code and the maximum power is greater than the power of the machine.
3. Every time the machine is turned on, the heating plate must be preheated for a period of time to reach the target temperature. The first warm-up may take 20 minutes to reach 360°F/ 180°C. It is recommended to test on a scrap piece of material prior to first use. After finishing any project, turn off and unplug the heat press.

Maintenance and care of the machine

- a. Do not touch the heat plate when the machine is on or after use. The plate can get very hot. Allow ample time for the plate to cool after use.
- b. Do not let the power cord touch the heating plate.
- c. Do not set the temperature above **400°F / 210°C** for an extended period of time, this will help extend the life of the machine.
- d. Keep the machine dry, do not store in an area with high humidity.
- e. Ensure the machine is fully cooled before moving, packaging, or storing
- f. Turn off for 15 minutes after 4 hours of continuous use.
- g. Don't operate other high-power equipment on the same circuit.
- h. Do not disassemble the heat press.
- i. Please do not operate heat press with a damaged cord or if the equipment has been broken.
- j. Please do not immerse the heat press in water or other liquid.
- k. In case of thunderstorms / adverse working conditions, please turn the machine off and unplug from the outlet.
- l. When not in use, store heat press open.

Suggested Temperature Time

Substrate	Temperature	Time(s)	Attention
Ceramic Mug	360°F / 180°C	120-170 Seconds	Sublimation Paper, Sublimation Ink, Print Mirror Mode, Moderate Pressure
Glass Beer Cup	360°F / 180°C	150-180 Seconds	Sublimation Paper, Sublimation Ink, Print Mirror Mode, Moderate Pressure
Aluminum Bottle	340°F / 170°C	25-30 Seconds	Sublimation Paper, Sublimation Ink, Print Mirror Mode, Low Pressure, Remove Cap
Stainless Steel Bottle	340°F / 170°C	30-35 Seconds	Sublimation Paper, Sublimation Ink, Print Mirror Mode, Moderate Pressure
Heat Resistant Plastic Cup	230°F / 110°C	25-30 Seconds	Sublimation Paper, Sublimation Ink, Print Mirror Mode, Low Pressure

Place the cup in the middle of the mug attachment for evenly distributed heat.

Operation Process

1. Adjust the pressure

① Before pressing, please use the pressure knob to adjust the pressure between the mug and the mug attachment.

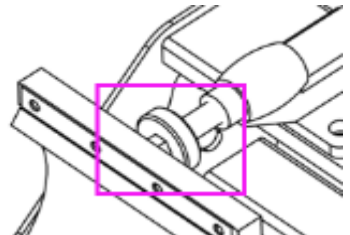

- ② Turn clockwise to increase pressure, turn counterclockwise to reduce pressure.
- ③ When adjusting the pressure, place the substrate on a silicone pad. Then push down the handle to find the suitable pressure.

2. Connect the power

- ① Check the power cord and ensure the press is on a flat stable surface.
- ② Connect the power cord to a grounded outlet with sufficient current and power.
- ③ Turn the power on and the panel should now light up. Please note the machine might give off a non-toxic odor for the first few uses. This is normal and will go away.

3. Setting the Time & Temperature



- 1) Setting the Target Temperature: Press "SET" button, when panel shows "SP", then press ▲ (up) or ▼ (down) to set the temperature. You may refer to "**Suggested Time and Temperature**" to determine the suitable temperature and time according to the materials you intend to use.
- 2) Setting the Target Time: Press "SET" button, when panel shows "S", then press ▲ (up) or ▼ (down) to set the time.
- 3) Press the "SET" button again for 3 seconds to save the temperature and time settings.
- 4) Working Temperature: After you save the target temperature and time, the panel

will show the working temperature, which is the current temperature of the heat press. The press will take some time to warm up. Please wait until the **working temperature** reaches the **target temperature** - only then the machine is ready to use.

RESET : The panel will count the number of presses automatically. Press “RESET” button for about 3 seconds, the usage counter will reset to zero.

Switch Between Celsius & Fahrenheit:

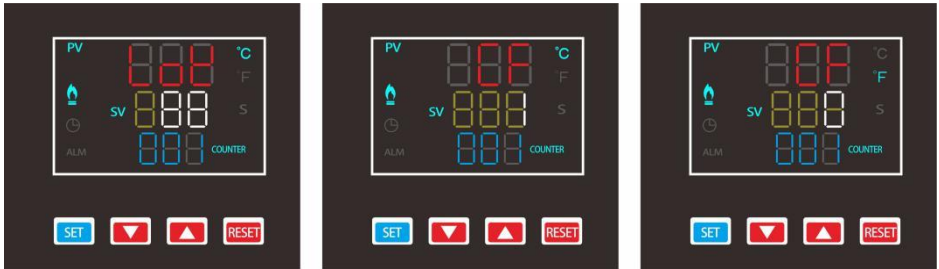

- 1) Press “**SET**” button for several seconds, the display shows "LOY"
- 2) Press button ▼ (down) or ▲ (up) for several times till the panel shows "88"
- 3) Press “**SET**” button for several times, when the display shows "CF", then press button ▼▲ to switch between Celsius and Fahrenheit.
- 4) Select "0" for Celsius and "1" for Fahrenheit.
- 5) Make your selection and press the “**SET**” button for 3 seconds to confirm the setting and exit.

4. Prepare consumables

- ① Place base of the mug into the press to pre-heat the substrate for 10-15 seconds.
- ② Please note the mug will be warm when applying the transfer.

5. Start transfer

- ① Attach the sublimation paper with the heat resistant tape, ensure the image side facing the mug.

② Please put the mug in the middle of heat pad to allow for even heat.

③ Put down the handle, press "ENTER" (red button on side of press) to start countdown. The temperature will drop a lot at this time, it's normal. Please Wait for the temperature to return to the set temperature before pressing the next mug or cup.

④ Press "ENTER" again when the machine beeps.

6. Retrieving the finished product

CAUTION: The mug will be extremely hot and can lead to burns. Do not handle the mug with bare hands.

Recommendation: Use a scrap mug to practice on to ensure correct heat, time, and pressure.

If you use Sublimation Paper, please read the [important instructions below](#).

Troubleshooting

- 1. Color is too light:** Time too short / Temp too low / Pressure too low. Please check each parameter one by one.
- 2. Image blur:** Time too long / Pressure too high / Temp too high, which causes the ink to spread / the vinyl film to melt/ the coating of substrate may be uneven, please check each parameter one by one.
- 3. Partial image blur:** Time too long / Pressure too high / Temp too high / **substrate coating is uneven / moved during transfer**, please check each parameter one by one.
- 4. Paper glued to substrate:** Temp too high / Pressure too heavy / Substrate coating is too thick / Ink is not dry after printing, please check each parameter one by one.

Machine Error Help

1. The machine does not turn on

Check plug / power switch / panel controller / fuse

2. At the beginning of the job the panel controller does not display the countdown/ after the countdown is completed, the buzzer does not sound

Check the countdown micro-switch.

3. Press cannot be opened

① Adjust the pressure knob counter clockwise to reduce the pressure, pull up on the handle.

② If it still cannot be opened, turn on the power switch and set the heating plate with higher temperature, then pull up on the handle.

4. After replacing the heating plate, the temp and time become abnormal/ the temp does not increase.

Reset the temp and time.

5.The machine keeps beeping

Press the "ENTER" button, please check if the temperature is too high

(Such as incorrect Celsius and Fahrenheit settings), voltage error.

6.After receiving the machine there is a strong odor

After passing the factory startup test, the silicone pad may produce a non-toxic odor, the smell will disappear after using the machine several times.

7.The square plate in the middle of the machine keeps shaking

Tighten the screws which attaches the plate to the press.

8. Fogging out

Like an iron, when the air humidity is high / the temp difference is high, heating may produce evaporation. This is normal.

9. Part of surface on the machine is rusted

This can happen due to storage of the press. A small area of rust on its surface will not have a negative effect on how the machine works.

10. When the fuse is burnt out

After powering off, use a key to open the fuse panel which is next to the power cord interface and install a new fuse.

For any questions, please [contact support@swingdesign.com](mailto:support@swingdesign.com) and get professional support.

Tips

1. Keep the machine clean. Dust can damage electronic accessories. Clean the machine and panel controller every six months.
2. Clean the mug mat with a damp soft cloth once a month. If it is difficult to clean, use mineral alcohol.
3. In order to maintain a good transfer effect of the heating plate, the heating plate needs to be carefully protected during use. It is always recommended to use a heat resistant protectant sheet between the plate and the project.
4. Lubricate all exposed rods once a year with WD-40 oil or any metal lubricant.
5. When the silicone pad / sponge elasticity is insufficient, it should be replaced.

About Sublimation Paper

1. Keep sublimation paper in a dry place. Put the unused paper back in the box. If it is kept outside the box for a long time, the paper may absorb the moisture in the air and curl which can result in poor transfers.
2. **Ink, Printer:** Use sublimation ink & paper for all sublimation blanks. Heat transfer and printable heat transfer vinyl can be used with the press on a variety of non-sublimation cups and mugs.
3. **Transfer process:** Select "Mirror Mode" when printing. If the color looks dark or dull after printing, this is normal. Sublimation paper will curl quickly when heated, it is recommended that heat resistant tape is used to hold the sublimation paper to the fabric or sublimation blank.

4.Other questions: Due to the large number of factors involved in sublimation, please check each of the following items:

① Whether the substrate is wet / expired / poor quality, the surface of the hard object must have a sublimation coating.

② Printer Settings: Set the paper to “High Quality Plain Paper/Photo Paper”, set the quality to “High Quality” and set the speed to “Slowest”. Click "More Options" to customize the color correction.

③ Whether the sublimation ink has expired/deteriorated. Ensure the print heads are clean and clear of dried ink.

④ Heat press heating plate is not hot enough/ large temperature fluctuations/ time is not enough / pressure too low. If **360°F/180°C** is set, please use a thermometer to test at **multiple positions on the heating plate**. It is normal for the heating plate to have slight heat fluctuations within a few degrees.

**Save 25% off All Siser Heat Transfer Vinyl (HTV) with Coupon Code:
SWINGHEATPRESS**

**Save 10% off all Sublimation Blanks with Coupon Code:
SWINGSUBBLANKS**

Contact Us

Swing Design

support@swingdesign.com

978-371-2211

www.swingdesign.com