

# VersaUV LEF-12i

## Master Guide

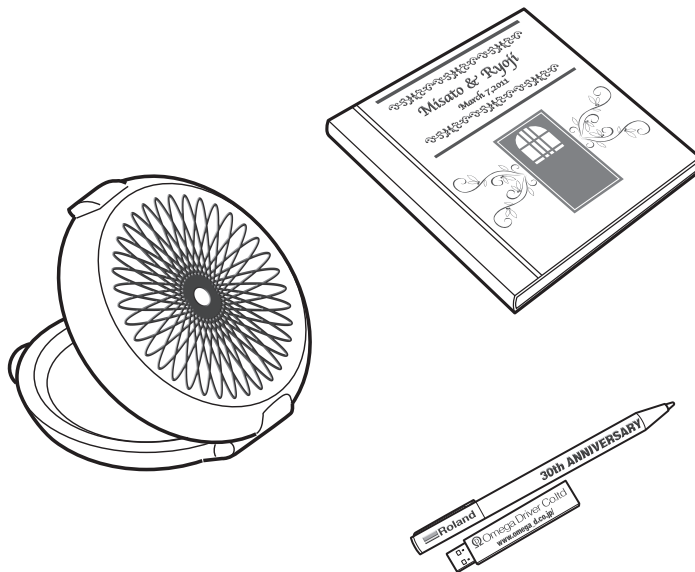

---

Thank you very much for purchasing this product.

- To ensure correct and safe usage with a full understanding of this product's performance, please be sure to read through this manual completely and store it in a safe location.
  - Unauthorized copying or transferal, in whole or in part, of this manual is prohibited.
  - The contents of this document and the specifications of this product are subject to change without notice.
  - This document and the product have been prepared and tested as much as possible. If you find any misprints or errors, please inform us.
  - Roland DG Corp. assumes no responsibility for any direct or indirect loss or damage that may occur through use of this product, regardless of any failure to perform on the part of this product.
  - Roland DG Corp. assumes no responsibility for any direct or indirect loss or damage that may occur with respect to any article made using this product.
-

This product uses GNU General Public License (GPL)/GNU Lesser General Public License (LGPL) software. You have the right to acquire, modify, and distribute the source code for this GPL/LGPL software. You can obtain the GPL/LGPL source code used in this product by downloading it from the Roland DG Corp. website. See the following URL for details on the basic method for acquiring the source code.

URL: <http://www.rolanddg.com/gpl/>

Roland DG Corporation has licensed the MMP technology from the TPL Group.

# Contents

Contents.....	1
<b>Chapter 1 Basic Operation.....</b>	<b>3</b>
Part Names and Functions.....	4
Printer Unit.....	4
Operation Panel.....	5
Menu List.....	6
Main Menu.....	6
Language and Unit Menu.....	8
Function Menu.....	8
Basic Operation.....	9
Basic Operation Flow.....	9
Switching the Power On and Off.....	10
How to Secure the Media.....	11
Set Height Position of Media (Automatic).....	13
Set Height Position of Media (Manual).....	15
Choosing How to Specify the Print Area.....	17
Specify the Print Area Directly.....	18
Specifying the Print Area from the Print Center Position.....	19
Printing Tests and Normal Cleaning.....	21
Starting the Print Operation.....	23
Printing Tests and Normal Cleaning After Daily Operations.....	28
<b>Chapter 2 Fully Utilizing the Machine.....</b>	<b>29</b>
Important Points to Check before Printing.....	30
Three Important Points (Measures for UV Reflected Light and Ink Mist).....	30
Fully Utilizing the Preset Function.....	32
Saving Current Media Setup with a Different Name.....	32
Load a Preset and Print/Fine-Tune and Print.....	33
Fully Utilizing the Media Loading Feature.....	35
Checking the Print Area (Preview Feature).....	35
Fine-Tuning the Set Print Area.....	36
Height Settings When the Print Surface is Uneven.....	37
Performing Automatic Adjustment to Continue Printing Even When the Media Comes into Contact with the Head Gap Sensor During Printing.....	38
Fully Utilizing the Print Quality Adjustment Feature.....	39
Preventing Soiling of the Media and Dot Drop-Out.....	39
Reducing Print Quality Degradation from Ink Mist (Ink Spatter).....	40
Re-curing Ink.....	41
Fully Utilizing Convenient Functions.....	42
Continuously Outputting Print Data.....	42
Reducing Output Time.....	43
Fully Utilizing the Administrative Features.....	44
Setting the Menu Language and the Units of Measurement.....	44
Setting the Activation Interval for Sleep Mode (Power-saving Feature).....	44
Deactivating the Sleep Mode (Power-saving Feature).....	45
Returning All Settings to Their Factory Default Values.....	45
Determining What Happens When Ink Runs Out.....	46
Viewing Information about the System of This Machine.....	47

<b>Chapter 3 Maintenance .....</b>	<b>49</b>
Introduction: About Maintenance.....	50
Automatic Maintenance Function and Notes.....	50
Keep Performing Maintenance .....	50
Alarm Function.....	50
Important Note on Draining Ink.....	50
Checking for Remaining Ink and Replacing Ink Cartridges.....	51
Checking for Remaining Ink .....	51
How to Replace Ink Cartridges.....	52
Maintenance That Should Be Performed Daily .....	54
Ink Cartridge Maintenance.....	54
Cleaning.....	54
About Care and Maintenance of the Print Heads.....	55
Disposing of Discharged Fluid.....	55
Periodic Cleaning Maintenance .....	58
About Each Cleaning Method.....	58
Medium and Powerful Cleaning .....	58
Manual Cleaning.....	60
When the White Ink Concentration Is Low .....	64
Restoring the White Ink Concentration.....	64
When Dot Drop-out Cannot be Cleared Up .....	65
When Dot Drop-Out Cannot Be Cleared Up for White or Gloss Ink .....	65
Cleaning All Print Heads .....	66
Replacing Consumable Parts.....	69
Replacing the Wipers .....	69
Replacing the Filter.....	72
When Moving the Unit.....	75
Procedure from Preparing to Move to Reinstallation.....	75
<b>Chapter 4 Appendix .....</b>	<b>77</b>
Read This Section Whenever You Face a Problem (FAQ) .....	78
Printer Does Not Run.....	78
Attractive Printing Is Impossible.....	80
The Print Heads Do Not Move.....	82
Handling Messages and Error Messages .....	83
A Message Appears .....	83
An Error Message Appears.....	85
Main Specifications .....	87
Dimensional Drawings .....	87
Locations of Power Rating and Serial Number Labels .....	88
Specification Table .....	89

# ***Chapter 1***

## ***Basic Operation***

---

Part Names and Functions .....	4
Printer Unit.....	4
Operation Panel.....	5
Menu List .....	6
Main Menu.....	6
Language and Unit Menu .....	8
Function Menu.....	8
Basic Operation .....	9
Basic Operation Flow .....	9
Switching the Power On and Off .....	10
How to Secure the Media .....	11
Set Height Position of Media (Automatic).....	13
Set Height Position of Media (Manual).....	15
Choosing How to Specify the Print Area.....	17
Specify the Print Area Directly.....	18
Specifying the Print Area from the Print Center Position.....	19
Printing Tests and Normal Cleaning .....	21
Starting the Print Operation .....	23
Printing Tests and Normal Cleaning After Daily Operations .....	28

# Part Names and Functions

## Printer Unit

### Front

#### Ink cartridge cover

Keep this cover closed except when necessary, such as when replacing the ink cartridges.

#### Front cover

Keep this closed except when necessary such as when loading media.

#### UV-LED device

#### Carriage fan

Spins while printing.

#### Cartridge slots

There are where ink cartridges are installed.

#### Head gap sensor

Used to detect height position of media.

#### Flat table

#### Print-head carriage

The print heads are inside this carriage.

#### Operation panel

P. 5, "Operation Panel"

#### Panel cover

#### Drain bottle

### Rear

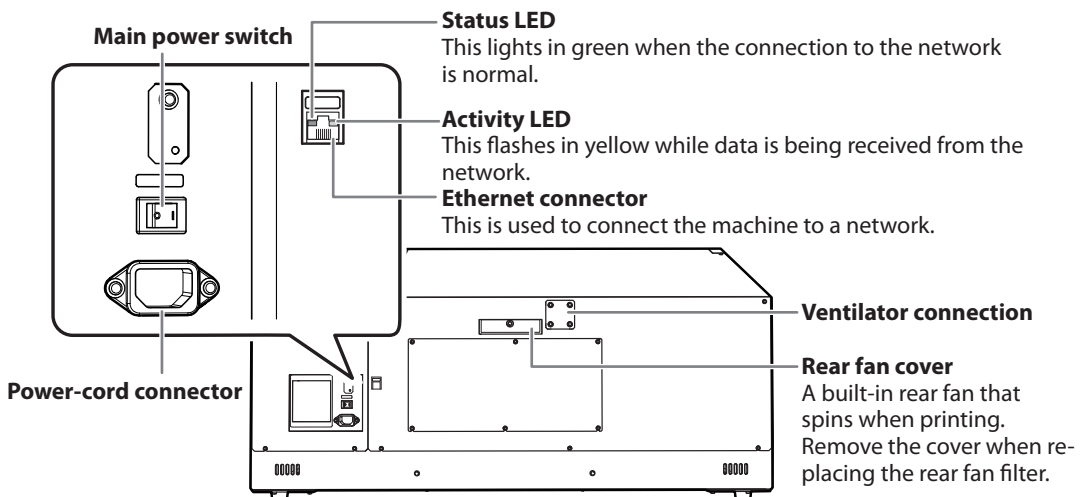

# Operation Panel

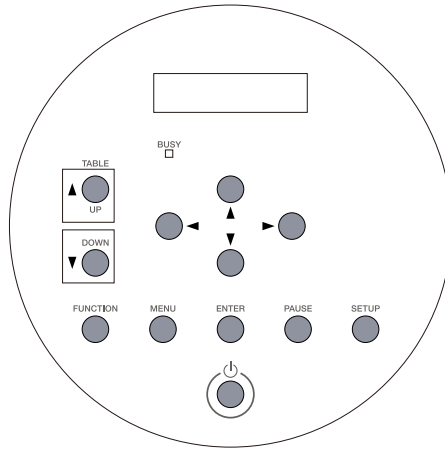

Part	Name	Description	Notation in this manual
	Display Screen	This displays various setting menus and other information.	
	Sub power switch	This switches the printer on and off. (To switch the printer off, hold down the switch for one second or longer). The light flashes slowly when the machine is in sleep mode.	
ENTER	ENTER key	Use this for such tasks as enabling setting values.	[ENTER]
MENU	MENU key	Press this to enter the menus for various settings.	[MENU]
FUNCTION	FUNCTION key	You press this when entering the setting menu for cleaning of the print heads, printing tests, and so on.	[FUNCTION]
PAUSE	PAUSE key	This pauses the printing operation. It lights when operation is paused.	[PAUSE]
	Cursor keys	Use these to select settings for menu items or to move the media. Moves 0.1 mm (3.94 mil) with one short press. Hold to move fast continuously. <ul style="list-style-type: none"> <li>• [▼] [▲]: Use these keys to move the flat table to the front and rear.</li> <li>• [◀] [▶]: Use these keys to move the print-head carriage.</li> </ul>	[◀] [▼] [▲] [▶]
	TABLE UP key	The flat table goes up.	[UP]
	TABLE DOWN key	The flat table goes down.	[DOWN]
BUSY	BUSY light	This indicator lights during printing and other such operations.	[BUSY]
SETUP	SETUP key	Press this when you load media.	[SETUP]

# Menu List

## Main Menu

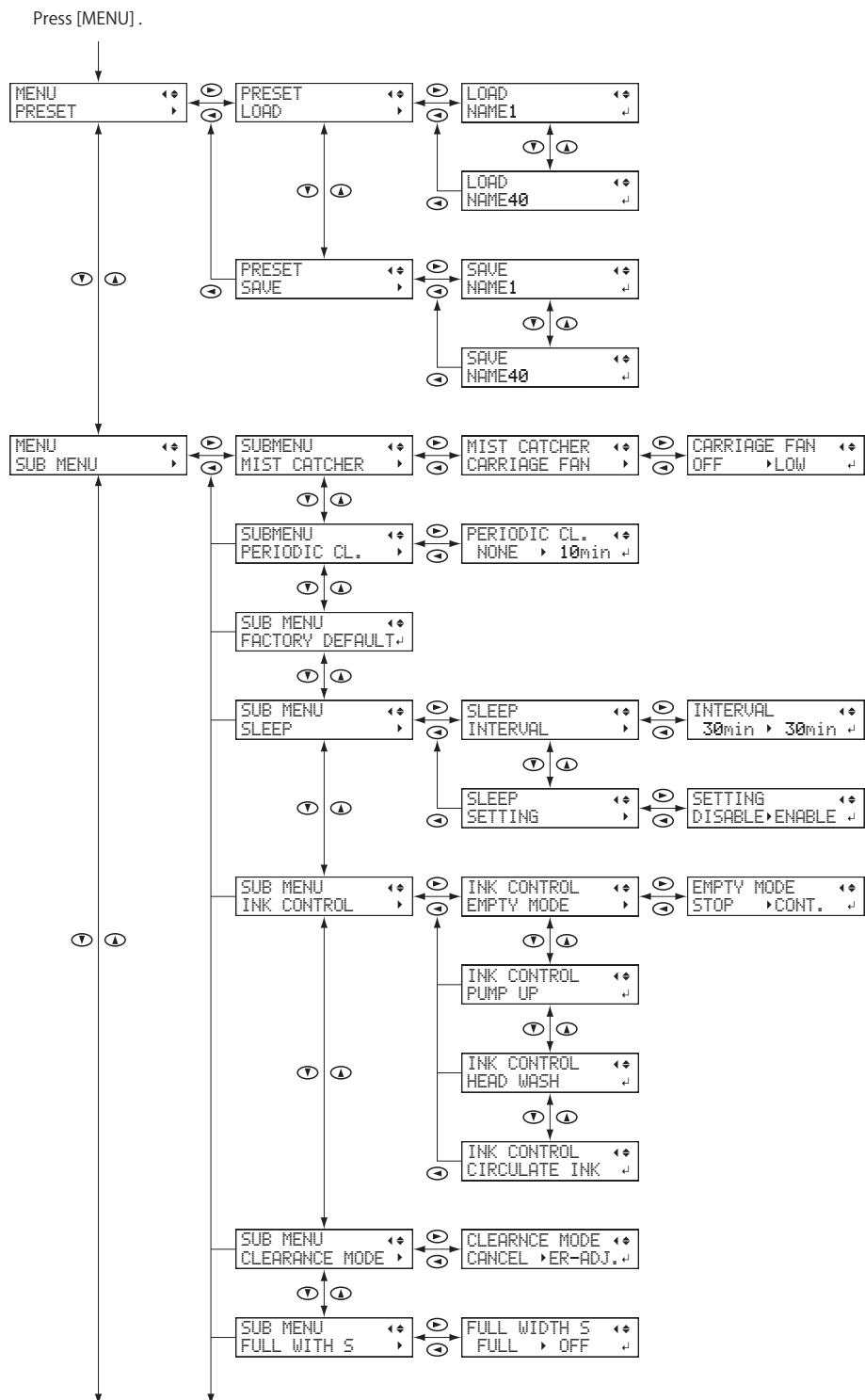



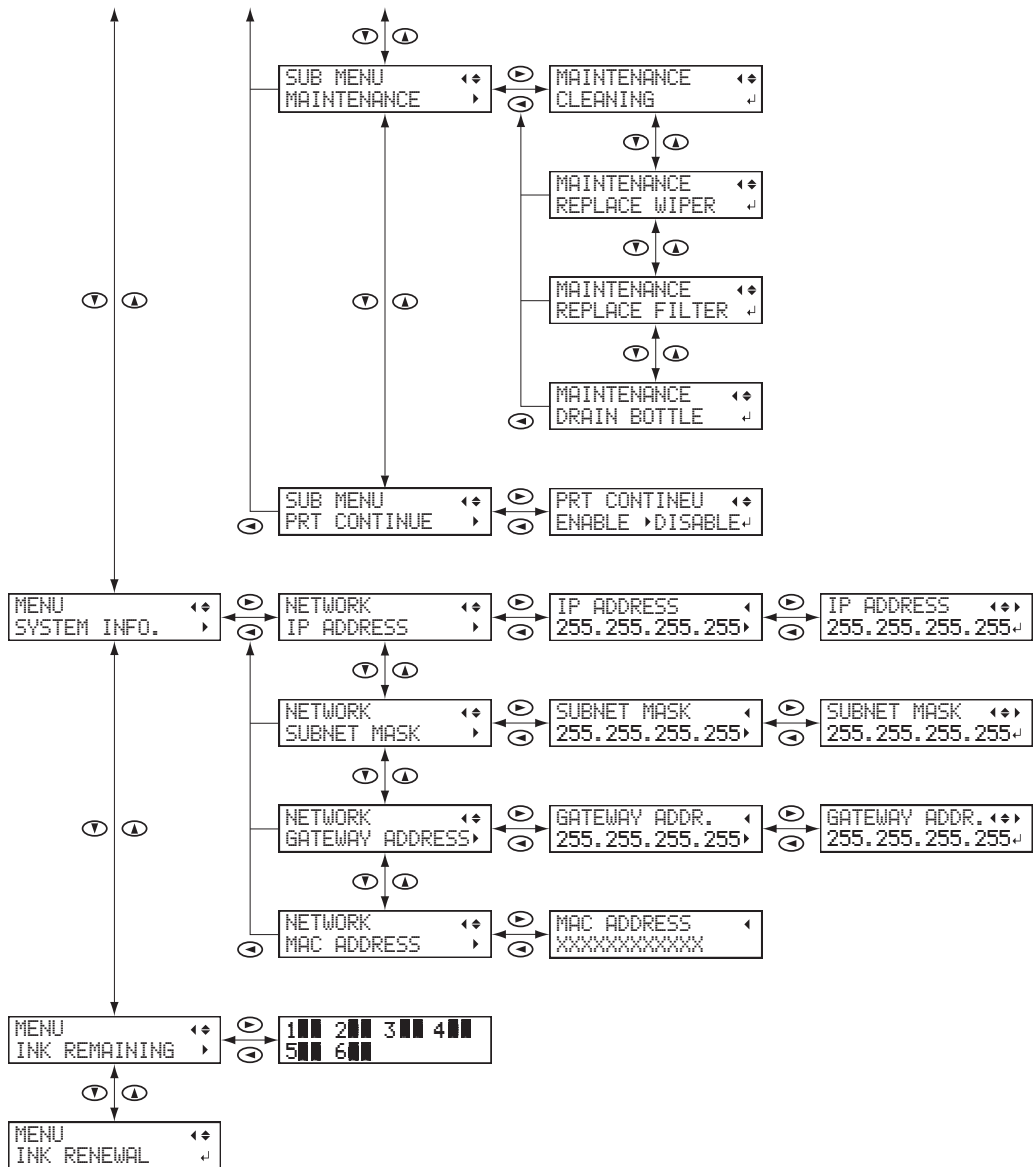

## Language and Unit Menu

While holding down [MENU], switch on the sub power.

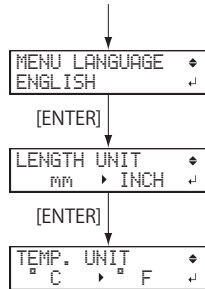

## Function Menu

Press [MENU].

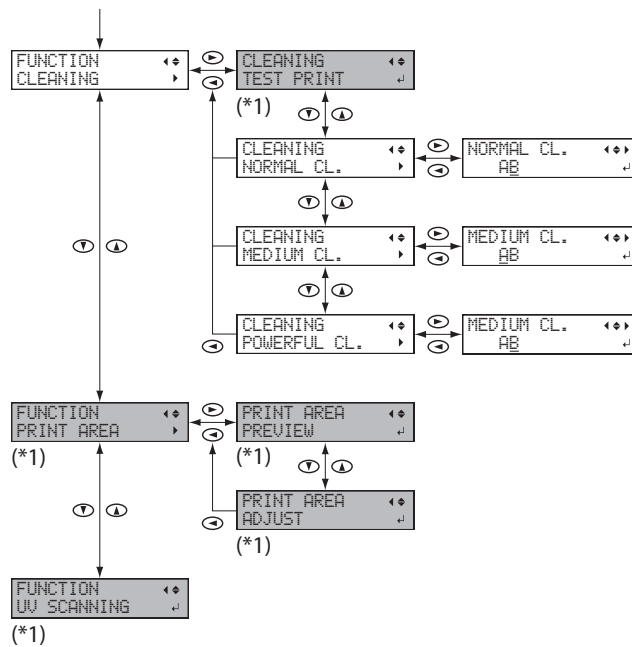

(\*1) Not displayed if the setup of media is not completed (when [SETUP] is off or flashing).

# Basic Operation

## Basic Operation Flow

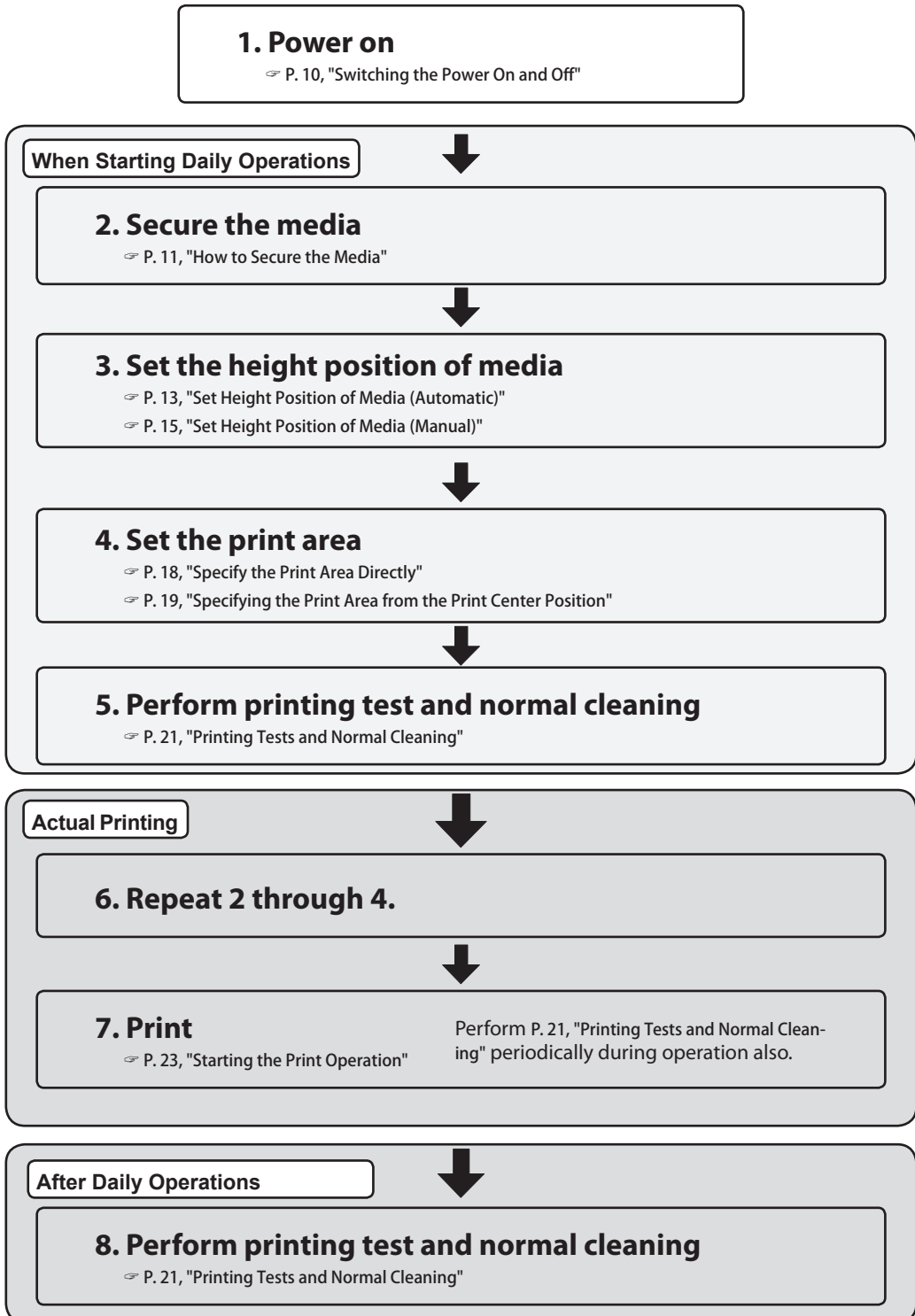

## Switching the Power On and Off

### Switch On

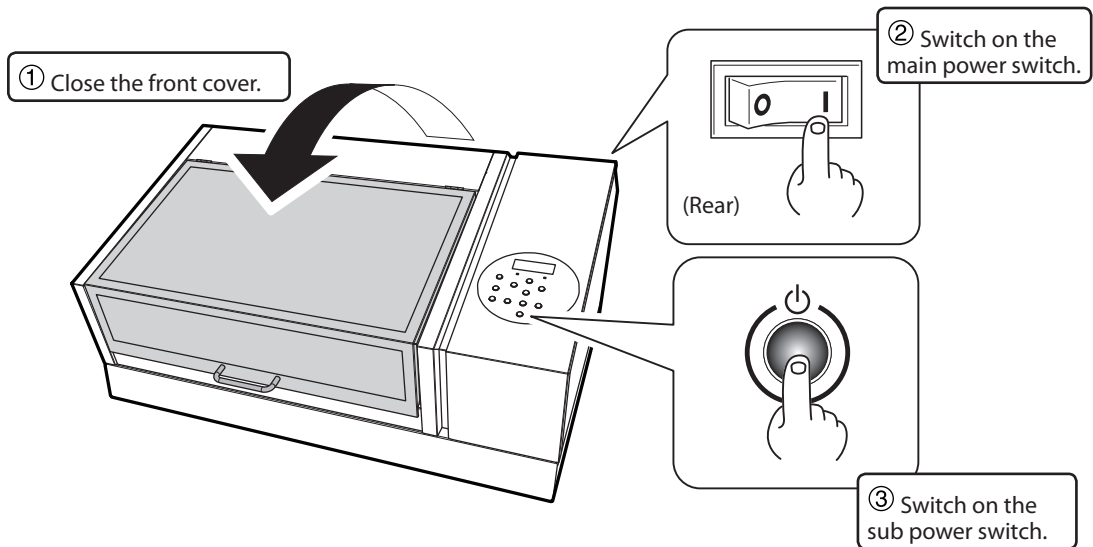

### Switch Off

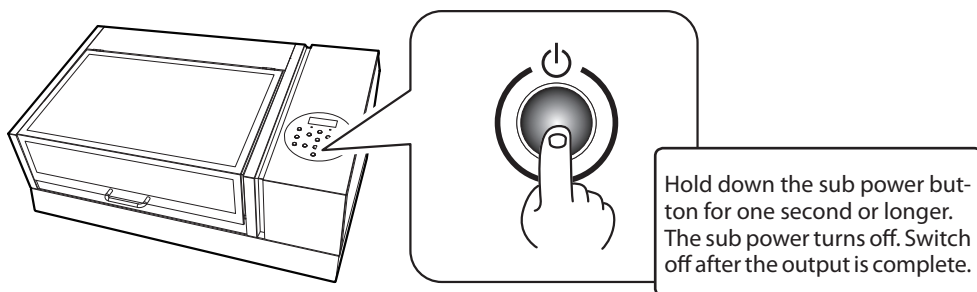

#### IMPORTANT!

**Leave the main power switched on at all times.**

Never switch off the main power. When the main power is on, the automatic maintenance function is carried out periodically. If the automatic maintenance is not carried out, the printer may malfunction. For example, the print heads may be damaged.

**Never switch off the main power or unplug the power cord suddenly while operation is in progress.**

Switching off the main power or unplugging the power cord suddenly while operation is in progress may damage the print heads. Be sure to first switch off the sub power. If the main power is accidentally switched off, immediately turn the main and sub power back on.

## How to Secure the Media

### Conditions for Usable Media

\*In this manual, the printing material used for output is called "media."

**Maximum size: Width 335 mm (13.19 in.) x depth 310 mm (12.2 in.) x height 100 mm (3.94 in.)**

**Maximum weight: 5 kg (11.02 lb.)**

#### IMPORTANT!

- Do not use media that is charged with static electricity.
- This printer cannot print on all materials. When selecting media, be sure to carry out testing in advance to make sure that satisfactory print quality can be obtained.
- There is a limit to the variation in the unevenness on the print surface.
  - ☞ P. 37, "Height Settings When the Print Surface is Uneven"
- Depending on the type of media and the installation method, the height may not be set correctly. The machine may malfunction if printing is performed under these conditions. Do not use the following types of media.

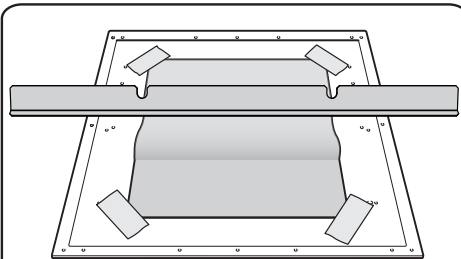

#### Media that easily becomes loose

If the media becomes loose, the head gap sensor cannot detect the height correctly. Be sure to secure the media without looseness. If the media does become loose, you can use an adhesive sheet to hold it in place.

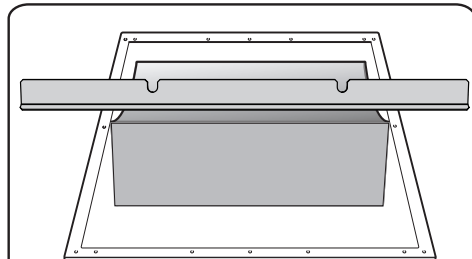

#### Media made from soft material

If the media is made from soft material, the pressure applied against the head gap sensor is too weak. This prevents it from detecting the height correctly.

---

## Printable Area

---

**Maximum Printable Area: Width 305 mm (12.01 in.) x depth 280 mm (11.03 in.) x height 100 mm (3.94 in.)**

\* The maximum printable area is inside the guide lines on the flat table.

\* The maximum size of the media and the printable area are different.

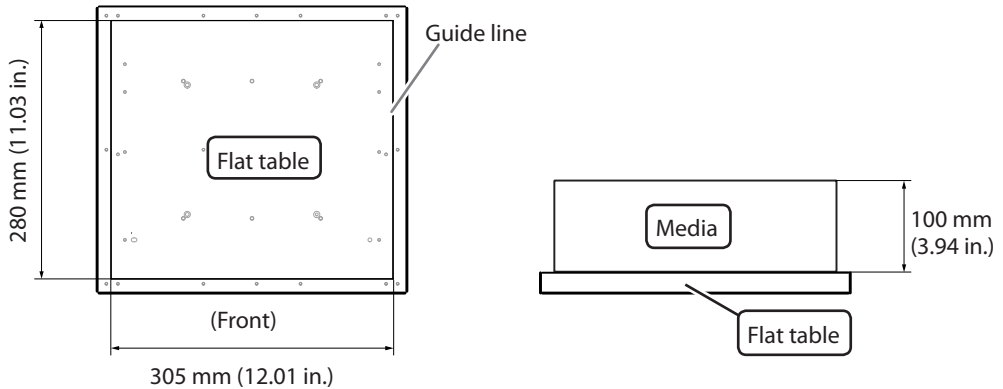

---

## How to Secure the Media

---

### Procedure

---

1



Make sure the screen in the figure is displayed.

**If it is not displayed, check that nothing has been placed on top of the flat table, and hold [SETUP] for a long time.**

The flat table will come forward into a position in which you can set up the media. If the screen in the figure is not displayed, you cannot set up the media.

2

### Secure the media in place.

For printing tests, use media for testing (width 80 mm (3.15 in.) x length 70 mm (2.76 in.) or more), and not the media you will actually use.

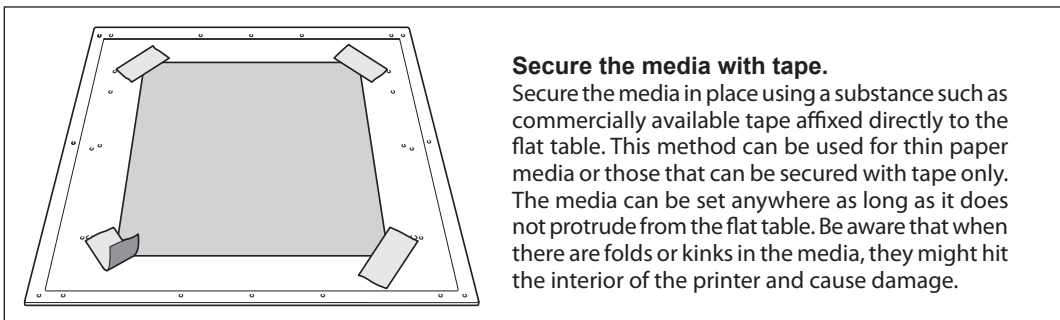

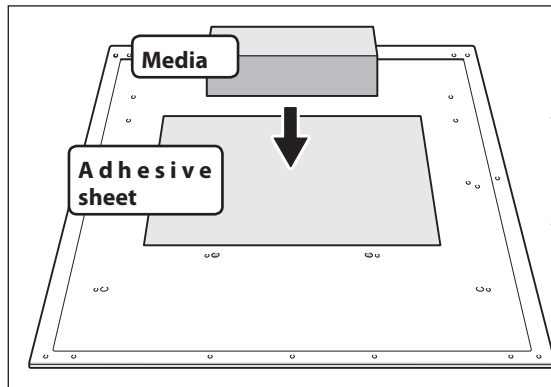

### Using an adhesive sheet

This method secures the media in place using an adhesive sheet, which is included. Load the adhesive sheet on the flat table, and press the media on top of the sheet to set.

The media can be set anywhere as long as it does not protrude from the flat table.

## Set Height Position of Media (Automatic)

This setup sets the media's height position automatically to a suitable position while printing. While setting up, the flat table moves automatically and detects the media height when the media touches the head gap sensor.

**\* If the print surface is uneven, there is a limit to the area of unevenness.**

☞ P. 37, "Height Settings When the Print Surface is Uneven"

When you do not want to let the head gap sensor to touch the media, automatic setup is not suitable in the following cases. Set the height manually.

☞ P. 15, "Set Height Position of Media (Manual)"

### Procedure

**1 Secure the media in place on the flat table.**

☞ P. 11, "How to Secure the Media"

**2 Close the front cover.**

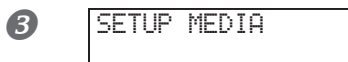

**Press [SETUP].**

[SETUP] starts to flash.

**4 Press [▲] [▼] [UP] [DOWN] to move the flat table.**

Move the print surface to a position 10 mm (0.39 in.) away from the head gap sensor.

This step can be performed with the front cover open.

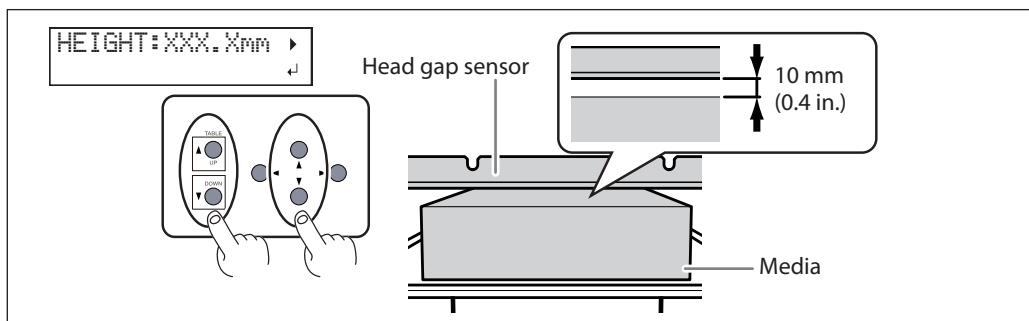

- 5 Press [▶].  
If the front cover is open, close it.

**NOTE: Check the height of the media again.**

The following step moves the flat table rearward. Check again that the height of the media has been adjusted so that the media does not come in contact with the head gap sensor. If the media hits the head gap sensor, the media may be damaged or the head gap sensor may fail. To re-adjust the height of the media, press [◀] and redo steps from Step 3.

- 6  Press [ENTER].

The flat table moves, and media height detection starts. The flat table rises while moving backward and forward until the media reaches a position where it comes in contact with the head gap sensor. The media's height will be set automatically to a position about 1 mm (0.04 in.) away from the ink emission surface of the print heads.

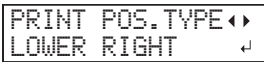

When the flat table stops moving, the screen shown on the left appears. Proceed to P. 17, "Choosing How to Specify the Print Area".



## Set Height Position of Media (Manual)

Set the media's height position manually to a position suitable for printing.

Manual setup takes a little longer than the automatic setup because alignment is done by sight, but use it when you do not want to let the head gap sensor to touch the media. (The head gap sensor touches the media in automatic setup.)

**\* If the print surface is uneven, there is a limit to the area of unevenness.**

☞ P. 37, "Height Settings When the Print Surface is Uneven"

### Procedure

**1 Secure the media in place on the flat table.**

☞ P. 11, "How to Secure the Media"

**2 Close the front cover.**

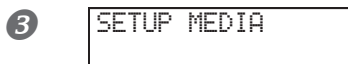

**Press [SETUP].**  
[SETUP] starts to flash.

**4 Press [▲] [▼] [UP] [DOWN] to move the flat table.**

Move the head gap sensor as close as possible to the print surface until they are in a position where they are just about to touch.

This step can be performed with the front cover open.

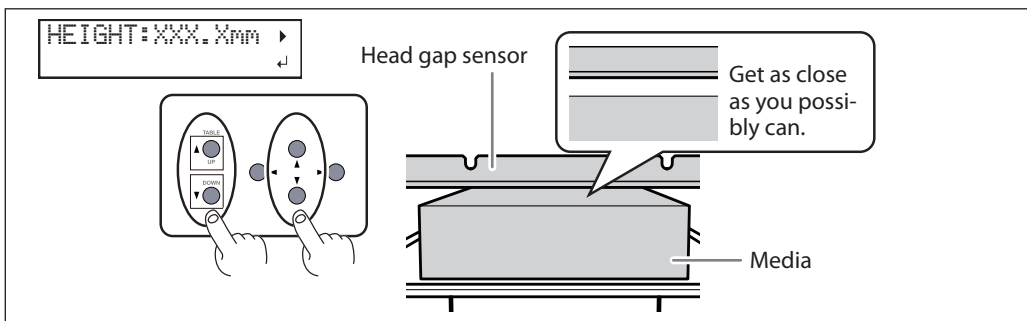

When you press [▶] here, the screen in the figure is displayed. Press [◀] to return to the original screen. Pressing [ENTER] starts automatic height detection. During automatic detection, the head gap sensor

comes into contact with the media.

**5 When the location is set, press [ENTER].**

6

```
CHECK TABLE
      HIGHT  ↵
```

**Press [▲] [▼] to select "YES" or "NO."**

If you want to check that the height of the media is correctly adjusted, select "YES."

Otherwise, select "NO."

**NOTE: If you select "YES," check the height of the media again.**

If you select "YES," the following step moves the flat table rearward. Check again that the height of the media has been adjusted so that the media does not come in contact with the head gap sensor.

If the media hits the head gap sensor, the media may be damaged or the head gap sensor may fail.

To re-adjust the height of the media, press and hold [SETUP] and redo steps from Step 3.

7

**Press [ENTER] to confirm your entry.**

**If you select "YES"**

```
NOW PROCESSING..
```

The flat table moves back and forth to check automatically that the media is not touching the head gap sensor.

```
PRINT POS. TYPE ◀▶
LOWER RIGHT  ↵
```

When the flat table stops moving, the screen shown on the left appears. Proceed to P. 17, "Choosing How to Specify the Print Area".

```
CHECK TABLE
      HIGHT  ↵
```

When the media comes into contact with the head gap sensor, the screen shown in the figure appears and the setup is canceled. If the media position becomes misaligned after the setup or, if some parts

are more higher than the print surface position set, the media may come in contact with the head gap sensor. Check and redo from Step 2.

**If you select "NO"**

```
PRINT POS. TYPE ◀▶
LOWER RIGHT  ↵
```

The screen on the left is displayed. Proceed to P. 17, "Choosing How to Specify the Print Area".

## Choosing How to Specify the Print Area

There are two ways you can set the print area on this machine. It is best to decide on a method depending on the shape of the object you are printing on.

<p><b>Specify the Print Area Directly</b></p>	<p>Enter the "Print-Start Position (lower right of print area)," and the "Width" and "Length" of the print area to specify the print area directly. This method is appropriate when the print site is level and you can clearly specify the print area.</p>
<p><b>Specifying the Print Area from the Print Center Position</b></p>	<p>When an approximate print area has been determined, specify the print area's width and length after specifying the center position of the print area. This method is appropriate when clear specification of the print area is difficult or when the print site is curved or uneven.</p>

### *For transparent media and high-gloss media with dark color used on the print surface*

A laser beam is used to specify the print area. Depending on the material used on the media, such as transparent media and high-gloss media with dark color used on the print surface, the laser beam is difficult to see. In such cases, the laser beam may become more visible by placing masking tape on the print surface and on the back.

***Print heads may return to the standby position automatically while specifying the print area.***

When you are specifying the print area and the print heads are above the flat table, the print heads return to the standby position automatically if you leave them in the same position for approximately 40 seconds. This behavior prevents print heads from drying out and breaking down. If the print heads return to the standby position, the menu goes back to the previous menu so you must repeat setup.

### ***Specifying the minimum print area enables print time reductions***

Specify the print area to the minimum necessary. Changing the width by which the print heads move shortens the print time (P. 43, "Reducing Output Time"). This function is effective when the print area or output data has a small width.

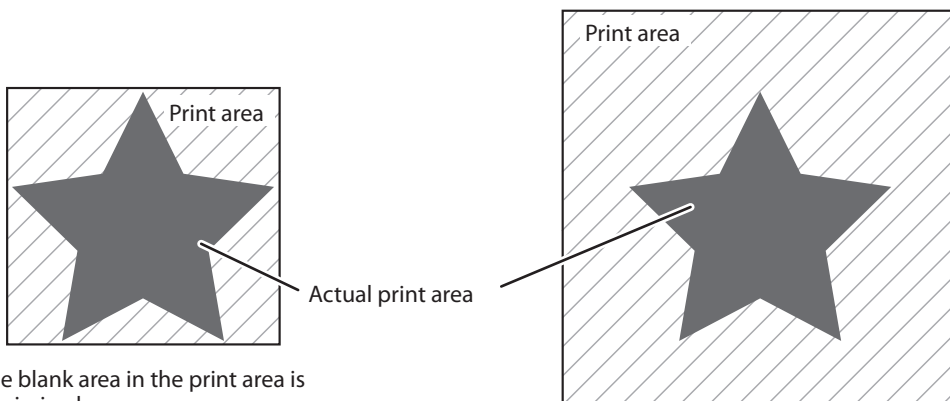

The blank area in the print area is minimized.

The print area has a lot of unnecessary blank areas.

## Specify the Print Area Directly

Enter the "Print-Start Position (lower right of print area)," and the "Width" and "Length" of the print area to specify the print area directly. This method is appropriate when the print site is level and you can clearly specify the print area.

### Procedure

**1 Set height position of media.**

☞ P. 13, "Set Height Position of Media (Automatic)"

☞ P. 15, "Set Height Position of Media (Manual)"

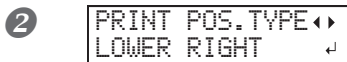

Press [◀] [▶] to select "Lower right."  
Press [ENTER] to confirm your entry.

**3 Press [▲], [▼], [◀], or [▶].**

The flat table moves to the rear, the print heads move to above the flat table, and the laser pointer illuminates.

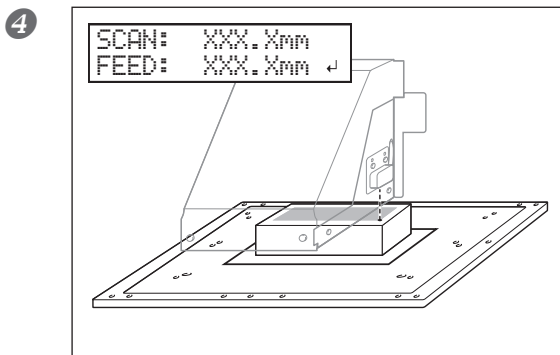

Press [▲] [▼] [◀] [▶] to move the laser pointer until it points to a position to the right foreground of the print area.

Press [ENTER] to confirm your entry.

The print heads return to the home position.

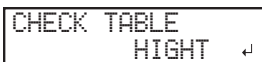

When the media touches the head gap sensor, the screen shown in the figure appears and there will be no setup information in the machine. Redo from P. 13, "Set Height Position of Media (Automatic)", or P. 15, "Set Height Position of Media (Manual)".

**5 Press [▲], [▼], [◀], or [▶].**

The flat table moves to the front and the print heads move to the left side of the flat table.

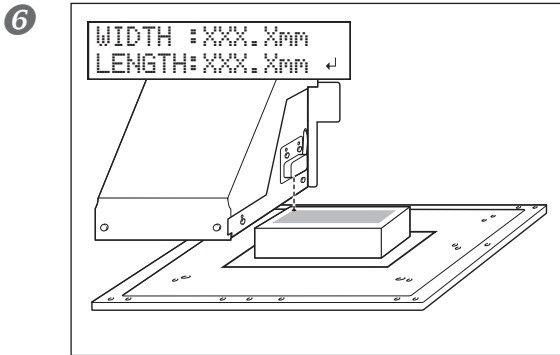

Press **[▲]** **[▼]** **[←]** **[→]** to move the laser pointer until it points to a position to the inner left of the print area.

For a test print, set width to 80 mm or more, and length to 70 mm or more. An error will occur and test prints cannot be performed if the area is smaller than this.

Press **[ENTER]** to confirm your entry.

The print area is specified. The print heads return to the home position.

W: XXXmm L: XXXmm  
H: XXXmm

Make sure the "W" (width), "L" (length), and "H" (height) values on the menu screen are as intended.

### 7 Close the front cover.

You can also fine-tune the print area after setup.

☞ P. 36, "Fine-Tuning the Set Print Area"

## Specifying the Print Area from the Print Center Position

When an approximate print area has been determined, specify the print area's width and length after specifying the center position of the print area. This method is appropriate when clear specification of the print area is difficult or when the print site is curved or uneven.

### Procedure

#### 1 Set height position of media.

☞ P. 15, "Set Height Position of Media (Manual)"

☞ P. 13, "Set Height Position of Media (Automatic)"

2

Press **[←]** **[→]** to select "CENTER."

Press **[ENTER]** to confirm your entry.

#### 3 Press **[▲]**, **[▼]**, **[←]**, or **[→]**.

The flat table moves to the rear, the print heads move to above the flat table, and the laser pointer illuminates.

4

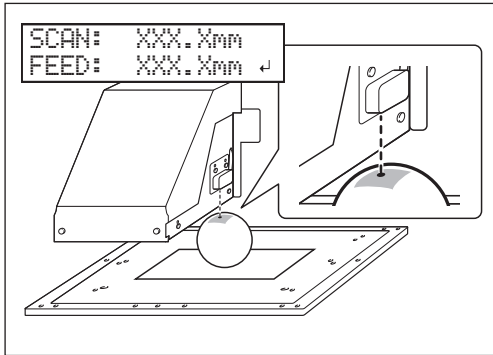

Press [▲] [▼] [←] [→] to move the laser pointer until it points to the center position of the area you want to print.

Press [ENTER] to confirm your entry.

The print heads return to the home position.

CHECK TABLE  
HEIGHT ←

When the media touches the head gap sensor, the screen shown in the figure appears and there will be no setup information in the machine. Redo from P. 13, "Set Height Position of Media (Automatic)", or P. 15, "Set Height Position of Media (Manual)".

5

WIDTH :XXX.Xmm  
LENGTH:XXX.Xmm ←

Press [▲] or [▼] to enter the length of the area you want to print.

Press [←] or [→] to enter the width of the area you want to print.

For a test print, set width to 80 mm or more, and length to 70 mm or more. An error will occur and test prints cannot be performed if the area is smaller than this.

Press [ENTER] to confirm your entry.

The print area is specified. The print heads return to the home position.

W:XXXmm L:XXXmm  
H:XXXmm

Make sure the "W" (width), "L" (length), and "H" (height) values on the menu screen are as intended.

6 Close the front cover.

You can also fine-tune the print area after setup.

☞ P. 36, "Fine-Tuning the Set Print Area"

## Printing Tests and Normal Cleaning

Make sure to perform a printing test in the following cases. Perform normal cleaning when there is a dot drop-out.

- **When starting operation for the day**
- **When ending operation for the day**

**Carry out printing tests periodically during daily operations also to make sure no dot drop-out occurs.**

If dot drop-out occurs in a printing test, perform cleaning of the print heads (Normal Cleaning). Leaving the dot drop-out untreated may damage the print heads. Please make sure to check each day after operation.

### How to Perform a Printing Test

#### Procedure

**1 Complete steps up to specifying the print area using test print media.**

⇒ P. 18, "Specify the Print Area Directly"

⇒ P. 19, "Specifying the Print Area from the Print Center Position"

Printing tests are used to check that no dot drop-out occurs. Use media for testing, and not the media that you will actually use.

**2 Press [FUNCTION].**

**3** 

Press [▶].

**4** 

Press [ENTER].

A test pattern is printed.

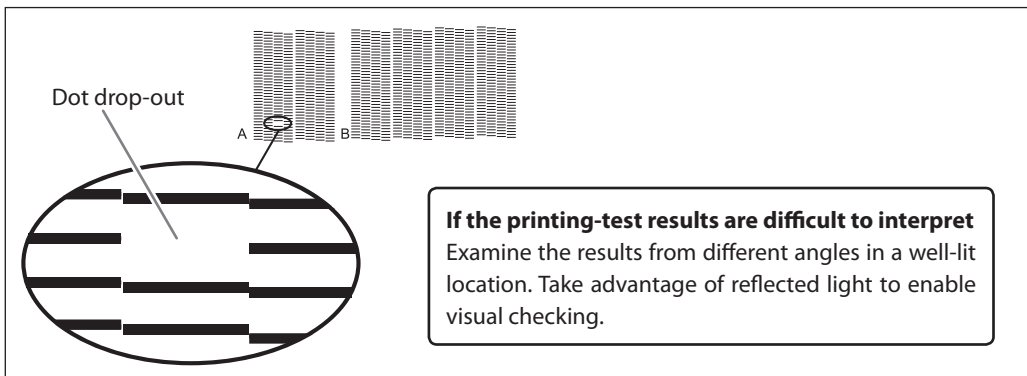

## How to Perform Normal Cleaning

### Procedure

1 Press [FUNCTION].

2 

Press [▼] to display the figure on the left.  
Press [▶], then [▼].

3 

Press [▶].

4 

Press [◀] or [▶] to select the group of print heads that is not to be cleaned.

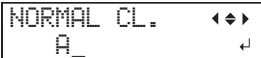
5 

Press [▲] or [▼] to get rid of the group display.  
Repeat this until only the groups that require cleaning are displayed, and then press [ENTER].

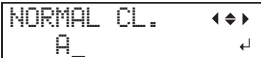
6 

**Normal cleaning starts.**

When finished, the screen shown in the figure appears again.



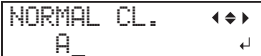

7 Press [MENU], then [◀] to go back to the original screen.

8 **Perform a printing test again to make sure the dot drop-out has been corrected.**

If the problem persists, try performing cleaning a second time.

If the printer has been used for a long period, the problem may not be fixed even after performing cleaning two or three times. If the problem does not go away, try cleaning using a different method.

☞ P. 58, "Medium and Powerful Cleaning"





## Starting the Print Operation

This section explains how to print from this machine, using the included RIP & PRINT management software Roland VersaWorks Dual (hereafter referred to as "VersaWorks Dual"). It assumes that you have already completed the following tasks.

- Installation of VersaWorks Dual
- Connecting VersaWorks Dual and this machine
- Learning the basic operation of VersaWorks Dual
  - ☞ "Roland VersaWorks Dual Installation Guide"
- Setup of media on this machine
  - ☞ P. 13, "Set Height Position of Media (Automatic)"
  - ☞ P. 15, "Set Height Position of Media (Manual)"
  - ☞ P. 18, "Specify the Print Area Directly"
  - ☞ P. 19, "Specifying the Print Area from the Print Center Position"
- Preparing print data
  - In this section, a file saved as a PDF file is used.

### 1. Load the print area set on this machine into VersaWorks Dual.

- 1 Start VersaWorks Dual.  
Check that:
  - **VersaWorks connects to this machine**
  - **Its status is "Ready to Print"**
- 2 **Double-click**  (or  ).  
The "Queue A Properties" dialog box appears. (Open the property for the input setting to use.)

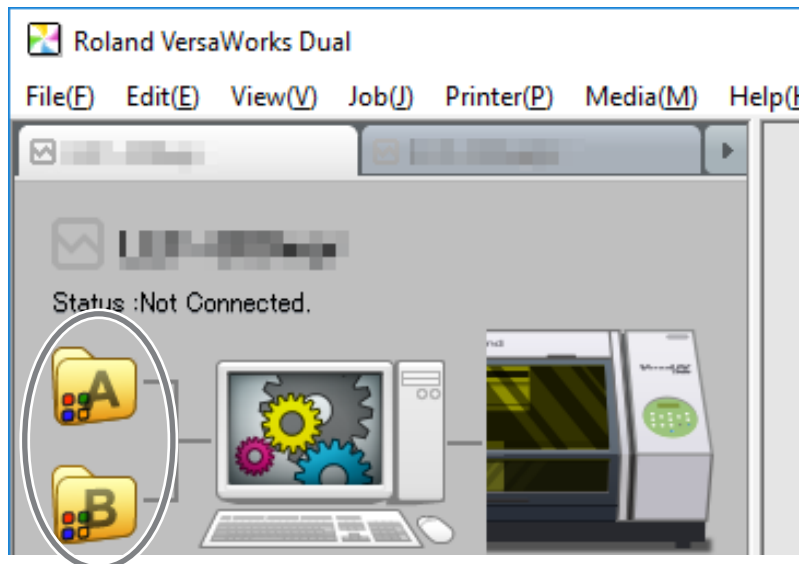

3

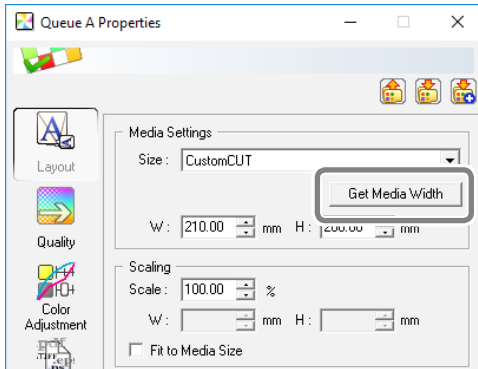

Click [Get Media Width].

Load the print area set on this machine into VersaWorks Dual.

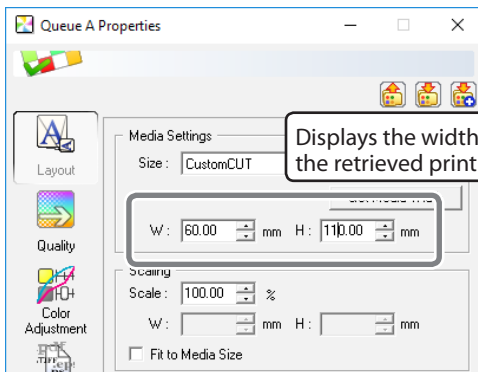

\* To configure other settings, see the VersaWorks Dual Installation Guide or the Help, or the included "Special Color Ink Guide."

4



Click [OK].

## 2. Output print data using VersaWorks Dual.

- 1 Go to “Job List,” click the “Queue A” tab, and drag the printing data to the queue A job list. (If the print job setting has been made in [Queue B], drag and drop the printing data on the job list of [Queue B].)

The contents of the data are displayed in the preview window, and the layout on the media is displayed in the layout window.

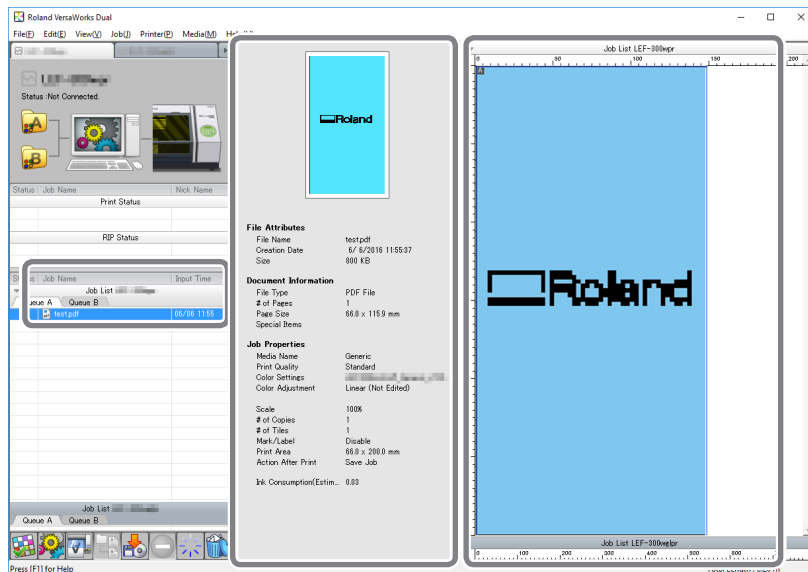

Preview window

Layout window

- 2 Double-click a print job in the job list.  
The "Job Settings" window appears.

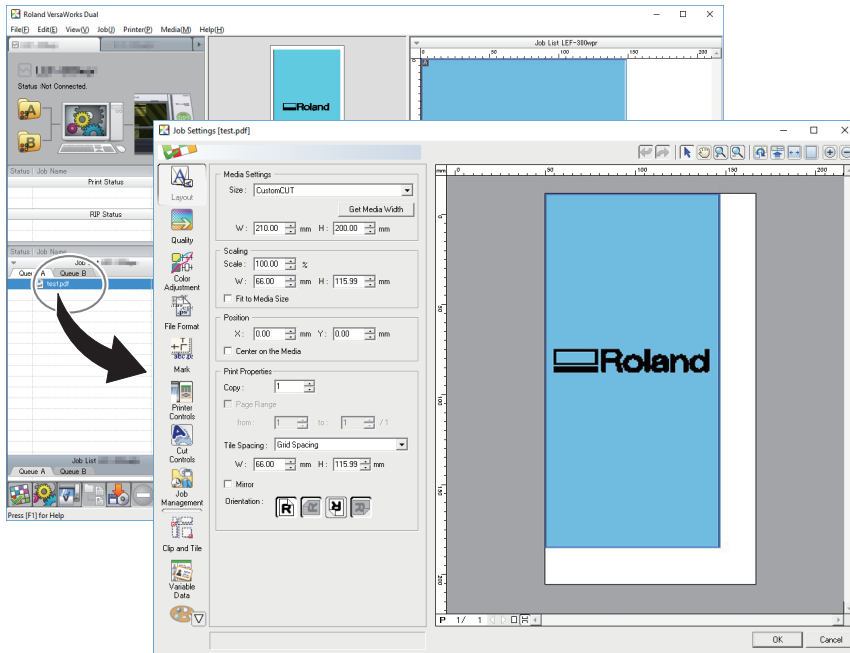

The white part in the layout area is the print area that was loaded in STEP 1. Print data that is not in the print area will not be printed.

Use this screen to fit the print data in the print area and adjust the position of the print data.

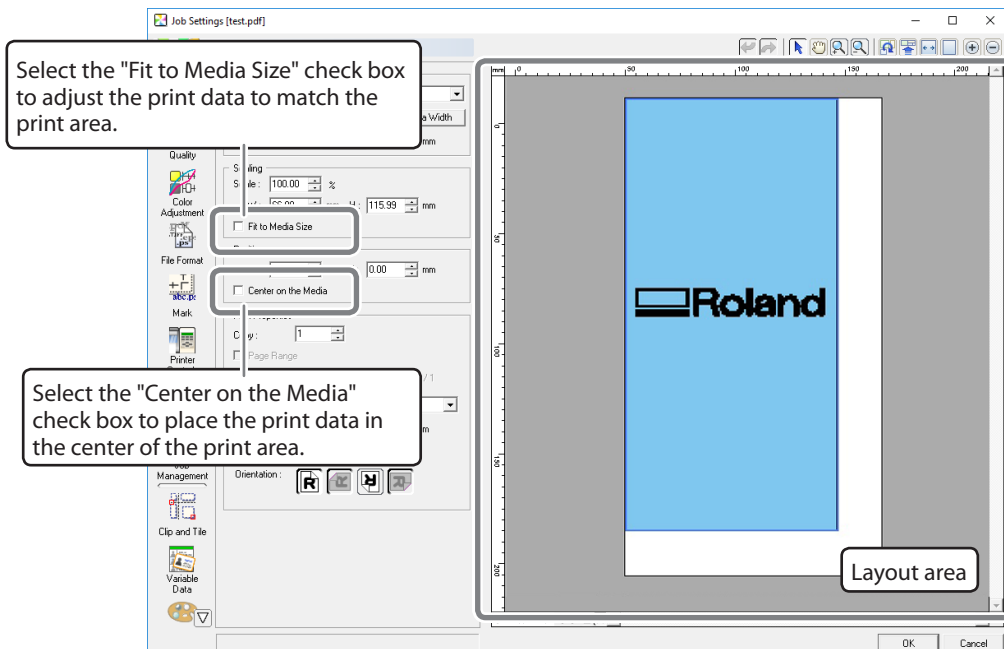

\* This is an example when "Center on the Media" is selected.

### ***The screen display appears in the opposite orientation.***

The orientation in the VersaWorks Dual screen display is the opposite of the actual print orientation. Make sure the media orientation is correct.

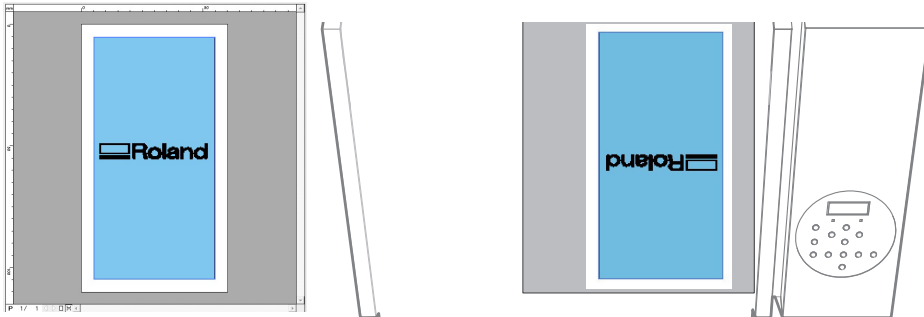

Orientation on the VersaWorks Dual screen

Actual print orientation

### **3 After you have adjusted the printing position, click [OK].**

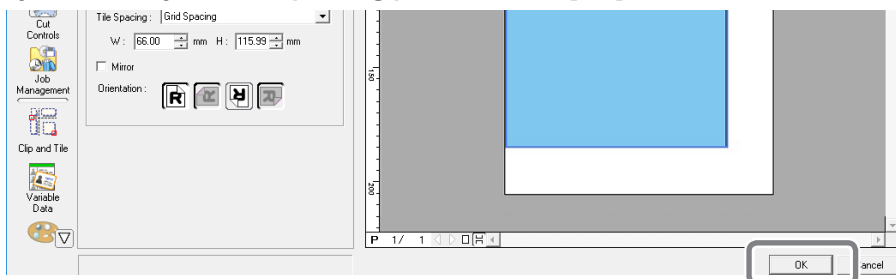

### **4**

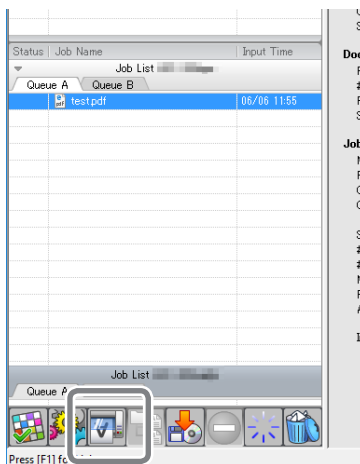

Click .

Printing will be started.

Operation at the time of completion of printing differs depending on the setting in "PRT CONINUE."

☞ P. 42, "Continuously Outputting Print Data"

**\* Make sure to check for dot drop-out by performing printing tests after daily operations. If dot drop-out is present, perform normal cleaning.**

☞ P. 28, "Printing Tests and Normal Cleaning After Daily Operations"

---

### Pausing or Canceling Printing

---

You can pause and cancel printing before it finishes. However, we do not recommend resuming printing because colors may be uneven in the place where output stopped.

#### Procedure

---

- 1 Press [PAUSE] before printing finishes.**  
The printing operation is paused.  
**Press [PAUSE] again to resume printing.**  
To cancel printing, go the next step without pressing [PAUSE].
- 2**  **When the screen shown in the figure appears, hold down [SETUP] for one second or longer.**  
The printing operation is canceled.
- 3 Stop sending the data from the computer.**

## Printing Tests and Normal Cleaning After Daily Operations

Make sure to check for dot drop-out by performing printing tests after daily operations. If dot drop-out is present, perform normal cleaning.

☞ P. 21, "Printing Tests and Normal Cleaning"

If problems such as dot drop-out persist even after you have performed normal cleaning several times, then perform medium or powerful cleaning.

☞ P. 58, "Periodic Cleaning Maintenance"

# **Chapter 2**

## **Fully Utilizing the Machine**

---

Important Points to Check before Printing .....	30
Three Important Points (Measures for UV Reflected Light and Ink Mist) .....	30
Fully Utilizing the Preset Function.....	32
Saving Current Media Setup with a Different Name.....	32
Load a Preset and Print/Fine-Tune and Print .....	33
Fully Utilizing the Media Loading Feature.....	35
Checking the Print Area (Preview Feature).....	35
Fine-Tuning the Set Print Area .....	36
Height Settings When the Print Surface is Uneven.....	37
Performing Automatic Adjustment to Continue Printing Even When the Media Comes into Contact with the Head Gap Sensor During Printing .....	38
Fully Utilizing the Print Quality Adjustment Feature .....	39
Preventing Soiling of the Media and Dot Drop-Out .....	39
Reducing Print Quality Degradation from Ink Mist (Ink Spatter).....	40
Re-curing Ink .....	41
Fully Utilizing Convenient Functions .....	42
Continuously Outputting Print Data .....	42
Reducing Output Time.....	43
Fully Utilizing the Administrative Features .....	44
Setting the Menu Language and the Units of Measurement .....	44
Setting the Activation Interval for Sleep Mode (Power-saving Feature) .....	44
Deactivating the Sleep Mode (Power-saving Feature).....	45
Returning All Settings to Their Factory Default Values.....	45
Determining What Happens When Ink Runs Out.....	46
Viewing Information about the System of This Machine.....	47

# Important Points to Check before Printing

## Three Important Points (Measures for UV Reflected Light and Ink Mist)

On this machine, ink affixed on the surface of the print heads might be cured by reflection of the UV lamp light and ink mist (ink splash upon printing). If ink affixed on the surface of the print heads is cured, it might cause dot drop-outs, and if you use the product without taking any measures, it might cause a failure which requires replacement of the print heads.

While daily cleaning is important to prevent dot drop-outs, there are also three important points to check before printing. Be sure to check the three points given below. Be sure to check the three points given below:

---

### 1. You cannot use a object which reflects light as a print object (media).

---

Mirrors and stainless materials, etc. which are likely to reflect the UV lamp light promote curing of the surface of the print heads, and therefore they cannot be used as a print object (media).

---

### 2. Make the distance between the surface of the print object (media) and the print heads as short as possible.

---

As the distance between the surface of the object to be printed on (the media) and the print heads increases, the likelihood of ink mist increases. When setting the height of media manually, make the distance as short as possible. When the height is automatically set, the distance is about 1 mm (39.4 mil).

☞ P. 13, "Set Height Position of Media (Automatic)"

☞ P. 15, "Set Height Position of Media (Manual)"

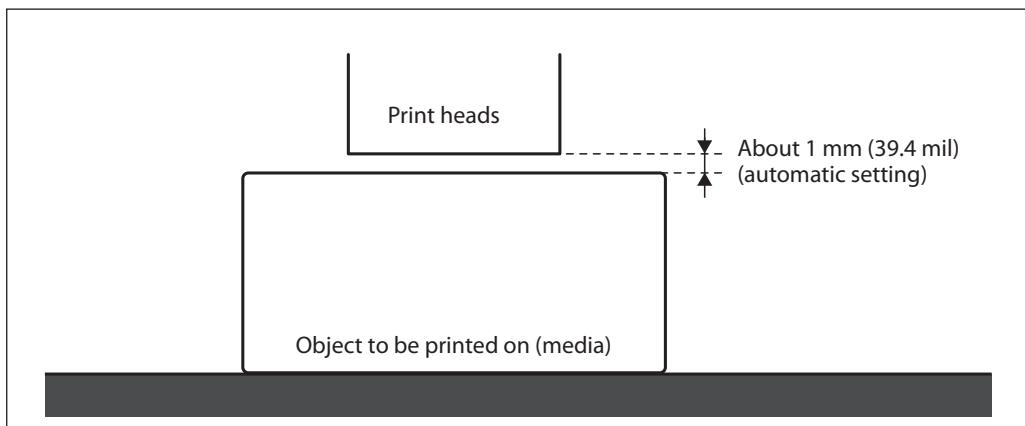



### 3. A jig might be required according to the size and shape of the print object (media).

Depending on the size and shape of the object to be printed on (the media), the distance between the object to be printed on (the media) and the print heads may increase, which will increase the likelihood of ink mist occurring. In the direction to which the print heads move, there must be a print object (media) and/or a jig in the areas of 40 mm (1.57 in.) on both right and left sides of the portion (width) of the data to be printed. In this situation, the difference in height between the surfaces of the object to be printed on (the media) and the jig must be less than 2 mm (78.7 mil).

- ☞ P. 13, "Set Height Position of Media (Automatic)"
- ☞ P. 15, "Set Height Position of Media (Manual)"
- ☞ P. 37, "Height Settings When the Print Surface is Uneven"

#### When a jig is required:

- The print object (media) is not large enough to spread over the areas of 40 mm (1.57 in.) on both right and left sides of the portion (width) of the data to be printed.
- The variation in height of the print object (media) surface is 2 mm (78.7 mil) or more.

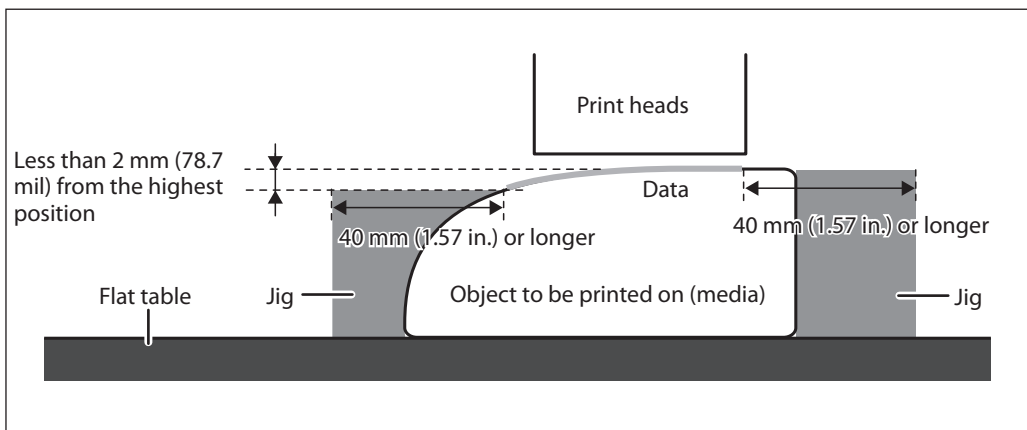
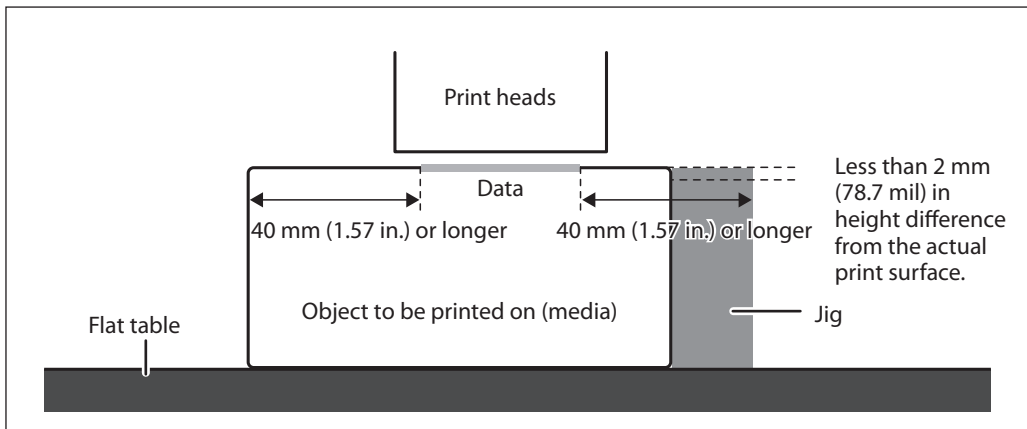



\* There are conditions in the height settings when the print object (media) surface has a height difference. For more information, refer to P. 37, "Height Settings When the Print Surface is Uneven".

# Fully Utilizing the Preset Function

## Saving Current Media Setup with a Different Name

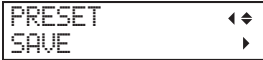
### Procedure

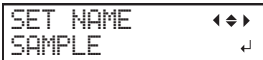
- 1 Set up the media (height position, print area) and make sure [SETUP] is lit.
- 2 Press [MENU].
- 3  Press [▶] [▼] in this order until the screen shown to the left appears.  
Press [▶].
- 4  Press [▲] [▼] to select one from NAME1 to NAME40.  
Press [ENTER] to confirm your entry.  
The current "height position of media" and "print area setting" are saved.
- 5  Press [▲] or [▼] to enter a character.  
When you have selected the character you want to enter, press [▶].  
The characters you can enter are "A" through "Z," "0" through "9," and the "-" character. You can enter up to 15 characters, including spaces.
- 6  Press [◀] or [▶] to enter the next character.  
Enter the following characters in the same way.  
When you have finished, press [ENTER] to confirm your entry.
- 7 Press [MENU], then [◀] to go back to the original screen.

### Description

The following settings configured in media setup can be saved as up to a maximum of 40 different types of presets.

- Height position of media
  - ☞ P. 13, "Set Height Position of Media (Automatic)"
  - ☞ P. 15, "Set Height Position of Media (Manual)"
- Print area (including print-start position)
  - ☞ P. 18, "Specify the Print Area Directly"
  - ☞ P. 19, "Specifying the Print Area from the Print Center Position"

You can assign a name to each preset. Using media names for these presets may aid recognition. These presets eliminate the need to perform the setting when you are using media with the same shape. You can also use presets and change just the print area, leaving the height setting unchanged.

- ☞ P. 33, "Load a Preset and Print/Fine-Tune and Print"

## Load a Preset and Print/Fine-Tune and Print

### Procedure

1 Press [MENU].

2  Press [▶] twice.

3  Press [▲] or [▼] to select the name of the preset you want to load.  
Press [ENTER] to confirm your entry.

 The screen shown in the figure appears. [SETUP] turns off.

4 Open the front cover, and then secure the media in place.

☞ P. 11, "How to Secure the Media"

5 Press [SETUP].

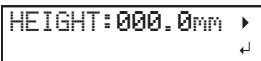
6  The loaded preset settings are displayed.  
**To change the height setting of the media  
Set height position of media.**

☞ P. 13, "Set Height Position of Media (Automatic)"

☞ P. 15, "Set Height Position of Media (Manual)"

**When choosing not to change the height setting of the media**

Press [ENTER].

7  The loaded preset settings are displayed.  
**To change the setting of the print area  
Set the print area.**

☞ P. 17, "Choosing How to Specify the Print Area"

☞ P. 18, "Specify the Print Area Directly"

☞ P. 19, "Specifying the Print Area from the Print Center Position"

**When the setup is completed, proceed to 10.**

**When choosing not to change the setting of the print area**

Press [ENTER].

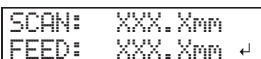
8  Press [ENTER].

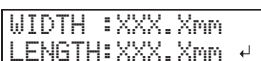
9  Press [ENTER].

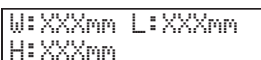
10  When the screen shown on the left appears, you can start printing.  
**Start printing.**

☞ P. 23, "Starting the Print Operation"

---

### Description

---

You can load a saved media preset setting and use it to print on media having the same size or print after making small changes in the setting. Select any one of 40 types of presets (when no names have been assigned, select from among NAME1 through NAME40) or DEFAULT (DEFAULT is the factory defaults for each setting).

# Fully Utilizing the Media Loading Feature

## Checking the Print Area (Preview Feature)

### Procedure

**1 Specify the print area.**

- ☞ P. 18, "Specify the Print Area Directly"
- ☞ P. 19, "Specifying the Print Area from the Print Center Position"

**2 Press [FUNCTION].**

**3**

FUNCTION	↔
PRINT AREA	▶

**Press [▼] to display the figure on the left.  
Press [▶].**

**4**

PRINT AREA	↔
PREVIEW	↵

**Press [ENTER].**  
The laser pointer displays the print area that has been set.

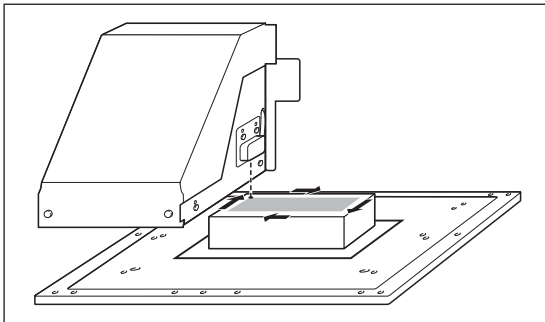

**5**

W: XXXmm	L: XXXmm
H: XXXmm	

**Press [FUNCTION] to go back to the original screen.**

### Description

This feature lets you check the set print area. You can check whether or not the print area that you intend is set before you start printing.

## Fine-Tuning the Set Print Area

### Procedure

**1 Specify the print area.**

- ☞ P. 18, "Specify the Print Area Directly"
- ☞ P. 19, "Specifying the Print Area from the Print Center Position"

**2 Press [FUNCTION].**

**3**

FUNCTION	◀▶
PRINT AREA	▶

**Press [▼] to display the figure on the left.  
Press [▶], then [▼].**

**4**

PRINT AREA	◀▶
ADJUST	↵

**Press [ENTER].**  
Move the laser pointer to the print-start position.

**5**

SCAN:	XXX.Xmm
FEED:	XXX.Xmm ↵

**Press [▲] [▼] [←] [▶], and refine the adjustment of the print-start position (lower right of print area).  
Press [ENTER] to confirm your entry.**  
Move the laser pointer to the print-end position.

**6**

WIDTH :XXX.Xmm
LENGTH:XXX.Xmm ↵

**Press [▲] [▼] [←] [▶], and refine the adjustment of the print-end position (print area's upper left).  
Press [ENTER] to confirm your entry.**

**7**

W:XXXmm	L:XXXmm
H:XXXmm	

**Press [FUNCTION] to go back to the original screen.**

### Description

This feature lets you make fine adjustments of the specified print area. If the specified print area is slightly displaced from the actual print area on the media, you can adjust the print start position and end position respectively.

## Height Settings When the Print Surface is Uneven

This machine can also print on uneven surfaces. However, note the following points regarding the height setting.

- **Automatically set the height for the highest position of the media.**

☞ P. 13, "Set Height Position of Media (Automatic)"

- **Gap between "highest position of the media" and "lowest position of the print surface" should be 2 mm (78.7 mil) or less (as a general guide).**

The print quality at the lower position degrades as the height gap widens.

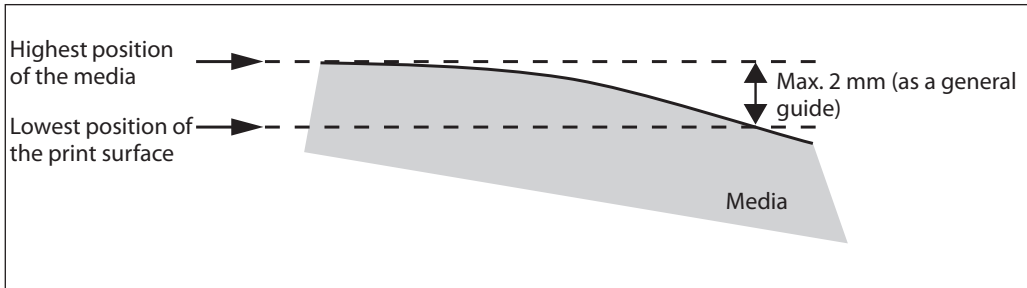

- **Printing on a surface that is perpendicular to print heads is not possible.**

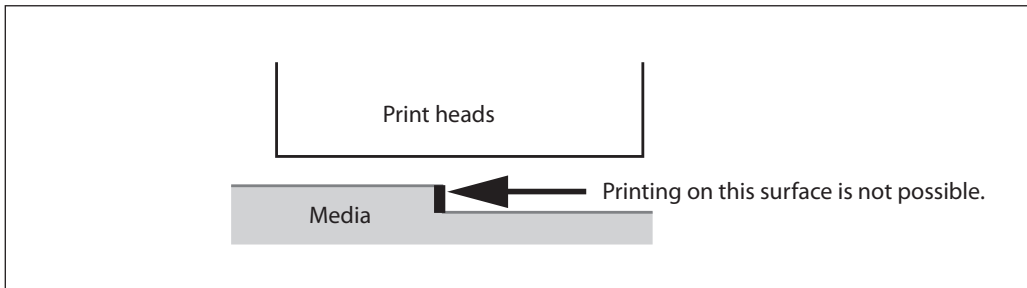

## Performing Automatic Adjustment to Continue Printing Even When the Media Comes into Contact with the Head Gap Sensor During Printing

### Procedure

1 Press [MENU].

2 

MENU	◀▶
SUB MENU	▶

Press [▼] several times until the screen shown on the left appears.

Press [▶].

3 

SUB MENU	◀▶
CLEARANCE MODE	▶

Press [▼] several times until the screen shown on the left appears.

Press [▶].

4 

CLEARANCE MODE	◀▶
CANCEL ▶ER-ADJ.	↵

Press [▲] or [▼] to select "RE-ADJ."

Press [ENTER] to confirm your entry.

5 Press [MENU], then [◀] to go back to the original screen.

### Description

This function is effective when using media that cannot be reprinted on. This setting allows the height to be readjusted automatically to continue printing even when the media moves out of position or lifts up and comes into contact with the head gap sensor during printing.\*

However, the change of the height settings may cause lower printing image quality. (During automatic readjustment, the head gap sensor will come into contact with the media as well.) Hence, proper printing requires that the media be secured properly before printing to keep it from moving out of position or lifting up.

☞ P. 11, "How to Secure the Media"

☞ P. 13, "Set Height Position of Media (Automatic)"

☞ P. 15, "Set Height Position of Media (Manual)"

Even if "RE-ADJ" is selected, printing and setup will be canceled in the following cases.\*\*

- When the flat table descends 10 mm (0.4 in.) or more during automatic readjustment
- When the media comes into contact with the head gap sensor during automatic readjustment, even if the flat table has moved to the bottom

If "CANCEL" is selected, printing and setup will be canceled without performing automatic readjustment.\*\*

\* For information on operation after printing is finished, refer to P. 84, "[READJUST TABLE HEIGHT]".

\*\* For information on operation after printing is canceled, refer to P. 85, "[CANCELED FOR TABLE HEIGHT]".

### Default Settings

[CLEARANCE MODE]: CANCEL



# Fully Utilizing the Print Quality Adjustment Feature

## Preventing Soiling of the Media and Dot Drop-Out

### Procedure

1 Press [MENU].

2 

MENU	◀◆
SUB MENU	▶

Press [▼] several times until the screen shown on the left appears.

Press [▶].

3 

SUBMENU	◀◆
PERIODIC CL.	▶

Press [▼] several times until the screen shown on the left appears.

Press [▶].

4 

PERIODIC CL.	◀◆
NONE ▶ 10min	↵

Press [▲] or [▼] to select an item.

**Page**

Automatic cleaning is performed every time before printing starts.

**5 to 990 minutes**

Automatic cleaning is performed when the cumulative printing time reaches the value you set here. The color may become uneven because the printing is paused.

**NONE**

Automatic cleaning is not performed.

Press [ENTER] to confirm your entry.

5 Press [MENU], then [←] to go back to the original screen.

### Description

In the following cases, ink tends to collect on the surface of the print heads. Under some conditions, this ink may be transferred to the media or cause dot drop-out.

➤ When you use media prone to a buildup of static charge

➤ When the ambient temperature is low

➤ When the variation in unevenness on the print surface is high (There is a limit to the unevenness of the print surface.)

☞ P. 37, "Height Settings When the Print Surface is Uneven"

Selecting "PAGE" or a value from "5 to 990 minutes," the ink buildup is removed before or during printing while printing is performed. Using "PAGE" or a value from "5 to 990 minutes" results in longer printing times.

### Default Settings

[PERIODIC CL.]: NONE

## Reducing Print Quality Degradation from Ink Mist (Ink Spatter)

### Procedure

1 Press [MENU].

2 

MENU	◀	▶
SUB MENU		

Press [▼] several times until the screen shown on the left appears.

Press [▶] three times.

3 

CARRIAGE FAN	◀	▶
HIGH	▶	MIDDLE

Press [▲] or [▼] to select an item.

Press [ENTER] to confirm your entry.

4 Press [MENU], then [◀] to go back to the original screen.

### Description

Under some conditions (such as low temperature or when a static charge is likely), a greater amount of ink mist (ink spatter during printing) may be produced and adversely affect the print quality. In these cases, you may be able to alleviate the symptom by lowering the rotation of the carriage fan. Whether the symptom can be alleviated depends on the temperature and media type. Be sure to check the print status as you adjust the setting.

However, the purpose of the carriage fan is to prevent ink buildup on the print heads. Lowering its rotation will lead to more dot drop-outs. This means, if you specify "MIDDLE," "LOW," or "OFF," you should perform normal cleaning more frequently. The "PERIODIC CL." setting is also effective against dot drop-outs .

☞ P. 21, "Printing Tests and Normal Cleaning"

☞ P. 39, "Preventing Soiling of the Media and Dot Drop-Out"

\* Only the carriage fan's setting can be changed. The rear fan setting cannot be changed.

### Default Settings

[CARRIAGE FAN]: HIGH

## Re-curing Ink

### POINT!

This feature cannot be used if media setup has been canceled. (When the media is being set up, [SETUP] lights up. Hold down [SETUP] for one second or longer to cancel setup. When canceled, [SETUP] turns off.)

### Procedure

1 Press [FUNCTION].

2  The screenshot shows a rectangular LCD screen with two lines of text. The top line reads 'FUNCTION' and the bottom line reads 'UV SCANNING'. To the right of the text are navigation icons: a left-pointing arrow and a right-pointing arrow on the top line, and a downward-pointing arrow on the bottom line.

Press [▼] several times until the screen shown on the left appears.

Press [ENTER].

The print heads move, and the print area is illuminated by the UV-LED lamp.

### Description

When the ink is not completely cured after printing is complete, cure the ink by illuminating it once again with the UV-LED lamp. A characteristic of UV ink is that it cures quickly when exposed to the UV lamp, but curing may be difficult for materials like cloth that absorb ink. The effect depends on the media material, but this function may alleviate the symptom.

# Fully Utilizing Convenient Functions

## Continuously Outputting Print Data

### Procedure

1 Press [MENU].

2 

MENU	◀◆
SUB MENU	▶

Press [▼] several times until the screen shown on the left appears.  
Press [▶], then [▲].

3 

SUB MENU	◀◆
PRT CONTINUE	▶

Press [▶].

4 

PRT CONTINUE	◀◆
ENABLE ▶DISABLE	↵

Press [▲] or [▼] to select "ENABLE."  
Press [ENTER] to confirm your entry.

5 Press [MENU], then [◀] to go back to the original screen.

### Description

#### If "ENABLE" is selected

When multiple print data entries are sent at a time from the computer, the print data entries can be output in a row. This feature is useful when you want to output multiple data in a row without replacing the media.

#### If "DISABLE" is selected

Even when multiple data are sent at a time from the computer, they are not output in a row and the screen shown below appears when one data is output. If you want to replace the media for each print data entry, select "DISABLE."

FINISHED PRINT	↵
----------------	---

Data from the computer is not accepted while this screen is displayed.

W: XXXmm L: XXXmm
H: XXXmm

Press [ENTER] to return to the screen as shown in the figure, at which point it will be possible to once more accept data from the computer.

### Default Settings

[PRT CONTINUE]: DISABLE

## Reducing Output Time

### Procedure

1 Press [MENU].

2 

MENU	◀◆
SUB MENU	▶

Press [▼] several times until the screen shown on the left appears.  
Press [▶].

3 

SUB MENU	◀◆
FULL WITH S	▶

Press [▼] several times until the screen shown on the left appears.  
Press [▶].

4 

FULL WIDTH S	◀◆
FULL ▶ OFF	↵

Press [▲] or [▼] to select "PRTAREA" or "OFF."  
**PRTAREA**

"PRTAREA" adjusts the operating range of the print heads to the preset print area.

#### **OFF**

"OFF" matches the range of print head movement to the output data. Movement is limited to the minimum amount necessary, and this can be expected to yield the fastest output. When this function is used, the time needed for the ink to cure is not constant, and an uneven color may result.

#### **FULL**

"FULL" makes the speed of media movement constant at all times and produces the most stable output result.

Press [ENTER] to confirm your entry.

5 Press [MENU], then [←] to go back to the original screen.

### Description

The output time is reduced by restricting the operating range of the print heads. This function is effective when the print area or output data has a small width.

### Default Settings



[FULL WIDTH S]: FULL

# Fully Utilizing the Administrative Features

## Setting the Menu Language and the Units of Measurement

This sets the language and units of measurement displayed on the operation panel screen.

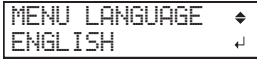
### Procedure

- 1 Hold down [MENU] and switch on the sub power.
- 2  Press [▲] or [▼] to select the display (menu) language.  
Press [ENTER] to confirm your entry.
- 3  Press [▲] or [▼] to select the measurement unit for length.  
Press [ENTER] to confirm your entry.
- 4  Press [▲] or [▼] to select the measurement unit for temperature.  
Press [ENTER] to confirm your entry.

### Default Settings



[MENU LANGUAGE]: ENGLISH

[LENGTH UNIT]: mm

[TEMP. UNIT]: °C

## Setting the Activation Interval for Sleep Mode (Power-saving Feature)

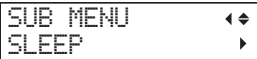
### Procedure

- 1 Press [MENU].
- 2  Press [▼] several times until the screen shown on the left appears.  
Press [▶].
- 3  Press [▲] several times until the screen shown on the left appears.  
Press [▶] twice.
- 4  Press [▲] or [▼] to select.  
Press [ENTER] to confirm your entry.
- 5 Press [MENU], then [←] to go back to the original screen.

### Default Settings

[INTERVAL]: 30 min.

## Deactivating the Sleep Mode (Power-saving Feature)

### Procedure

1 Press [MENU].

2 

Press [▼] several times until the screen shown on the left appears.  
Press [▶].

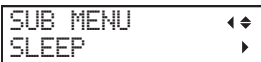
3 

Press [▲] several times until the screen shown on the left appears.  
Press [▶], then [▼].

4 

Press [▶].

5 

Press [▲] or [▼] to select "DISABLE."  
Press [ENTER] to confirm your entry.

6 Press [MENU], then [←] to go back to the original screen.

### Default Settings

[SETTING]: ENABLE

## Returning All Settings to Their Factory Default Values

This menu returns all settings to their factory default values. However, the settings for [MENU LANGUAGE], [LENGTH UNIT], and [TEMP. UNIT] are not returned to the factory defaults.

### Procedure

1 Press [MENU].

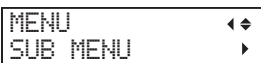
2 

Press [▼] several times until the screen shown on the left appears.  
Press [▶].

3 

Press [▼] several times until the screen shown on the left appears.  
Press [ENTER].

## Determining What Happens When Ink Runs Out

This lets you change, according to your purpose, the operation that takes place when an ink cartridge is empty.

### Procedure

1 Press [MENU].

2 

Press [▼] several times until the screen shown on the left appears.

Press [▶].

Press [▲] twice.

3 

Press [▶] twice.

4 

Press [▲] or [▼] to select.

[STOP]: Printing pauses immediately when a cartridge becomes empty.

[CONT.]: Printing does not stop automatically when a cartridge becomes empty. When a cartridge becomes empty, a warning beep sounds.

Press [ENTER] to confirm your entry.

5 Press [MENU], then [◀] to go back to the original screen.

### Description

When "STOP" is selected, printing pauses, so colors may be uneven. To prevent uneven colors, ensure that a sufficient amount of ink remains before you begin printing.

When "CONT." is selected, printing does not stop even if ink runs out completely. To replace the cartridge, wait until printing ends or press [PAUSE] to pause printing.

### Default Settings

[EMPTY MODE]: STOP



## Viewing Information about the System of This Machine

Note: For information on how to set up a network, refer to "First Step Guide."

### Procedure

1 Press [MENU].

2 

Press [▲] several times until the screen shown on the left appears.

You can check the following information:

[MODEL]: Model name

[SERIAL NO.]: Serial number

[INK]: Ink type

[FIRMWARE]: Firmware version

[NETWORK]: Network settings such as the IP address

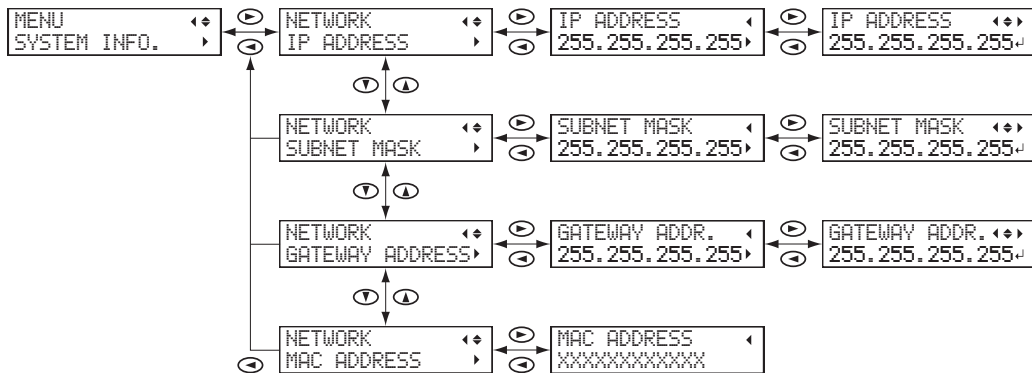



# Chapter 3

## Maintenance

---

Introduction: About Maintenance .....	50
Automatic Maintenance Function and Notes.....	50
Keep Performing Maintenance .....	50
Alarm Function .....	50
Important Note on Draining Ink.....	50
Checking for Remaining Ink and Replacing Ink Cartridges .....	51
Checking for Remaining Ink .....	51
How to Replace Ink Cartridges.....	52
Maintenance That Should Be Performed Daily.....	54
Ink Cartridge Maintenance .....	54
Cleaning .....	54
About Care and Maintenance of the Print Heads.....	55
Disposing of Discharged Fluid.....	55
Periodic Cleaning Maintenance .....	58
About Each Cleaning Method.....	58
Medium and Powerful Cleaning.....	58
Manual Cleaning.....	60
When the White Ink Concentration Is Low.....	64
Restoring the White Ink Concentration.....	64
When Dot Drop-out Cannot be Cleared Up .....	65
When Dot Drop-Out Cannot Be Cleared Up for White or Gloss Ink.....	65
Cleaning All Print Heads.....	66
Replacing Consumable Parts .....	69
Replacing the Wipers .....	69
Replacing the Filter.....	72
When Moving the Unit.....	75
Procedure from Preparing to Move to Reinstallation.....	75

# Introduction: About Maintenance

## Automatic Maintenance Function and Notes

This machine has a function that automatically performs maintenance periodically. Please observe the following because operations, such as preventing the print heads from drying out are performed.

- **Always leave the main power on.**
- **Do not leave the front cover open for a long time.**
- **Return to the top menu after specifying settings in the menus.**

## Keep Performing Maintenance

### Daily maintenance

Please perform regular maintenance to keep the machine in a condition to produce the best quality printing.

☞ P. 54, "Maintenance That Should Be Performed Daily"

### Periodic maintenance

There is maintenance you should perform periodically to ensure consistent output.

☞ P. 58, "Periodic Cleaning Maintenance"

### Switch the power on once every two weeks

Switch the sub power on once every two weeks. When you turn on the power, the machine automatically performs operations such as those to keep the print heads from drying out. Leaving the machine unused for a prolonged period may damage the print heads, so be sure to switch on the power to perform these automatic operations.

### Keep the machine at a constant temperature and relative humidity

Even when the machine is not in use, keep it at a temperature of 5 to 40°C (41 to 104°F) and a relative humidity of 20 to 80% RH (with no condensation). Not doing so may cause the machine to break down.

## Alarm Function

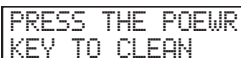

```
PRESS THE POWER  
KEY TO CLEAN
```

The alarm feature reminds you to switch on the sub power once a month. When the machine remains unused for about one month, this screen appears and a warning beep sounds. If this screen appears, switch on the sub power. When maintenance operations finish, switch off the sub power. This function operates when the printer's main power is turned on. Leave the main power switched on at all times even when the printer is to remain out of use for a prolonged period.

## Important Note on Draining Ink



```
INK CONTROL  ⬅➡  
PUMP UP      ↵
```

Although this machine has features for draining internal ink, it should never be used except in special cases. Allowing the machine to stand without ink for a prolonged period may damage the heads. Once ink has been filled, then as a rule the ink should never be drained.

# Checking for Remaining Ink and Replacing Ink Cartridges

## Checking for Remaining Ink

### Procedure

1 Press [MENU].



Press [▲] several times until the screen shown on the left appears.

Press [▶].



■ indicates the amount of ink remaining. When there are more ■, the amount of ink remaining is larger.

\* The displays shows approximately how much ink remains. It may differ somewhat from the actual amount remaining.

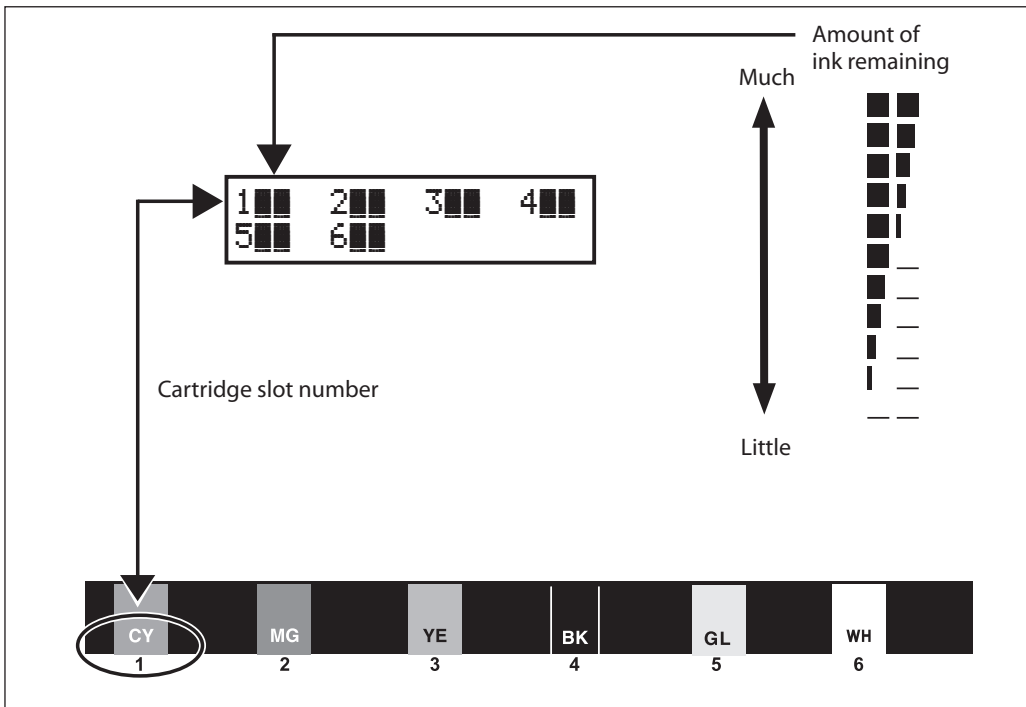

3 Press [MENU], then [◀] to go back to the original screen.

## How to Replace Ink Cartridges

When ink runs out, a warning beep sounds and printing pauses (unless the factory default settings have been changed). Pull out the empty cartridge and insert a new one. After replacing the cartridge, close the ink cartridge cover and front cover. Printing resumes.

### Procedure

1

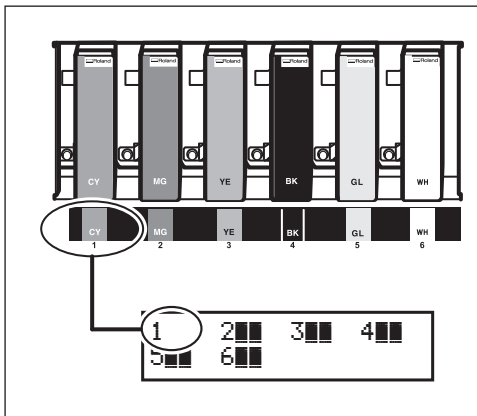

**Check the number flashing on the screen.**  
The ink at the flashing cartridge slot number is running out.

2

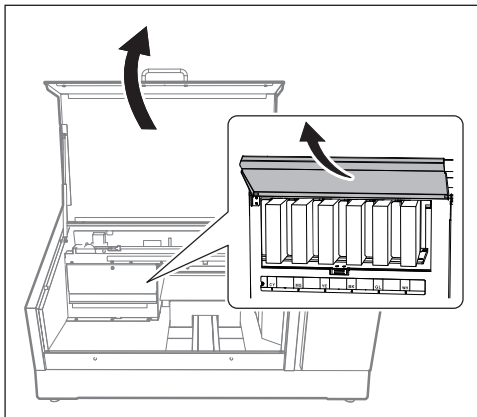

**Open the front cover.**  
**Open the ink cartridge cover.**

3

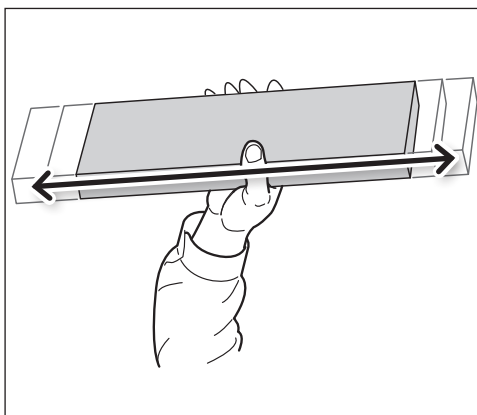

**Shake a new ink cartridge of the same type and color 50 times (about 15 seconds).**  
If ink components precipitate, it will not be possible to print with correct colors. So that the ink mixes well, hold both ends of the ink pouch and shake horizontally with a stroke length of around 5 cm.

4

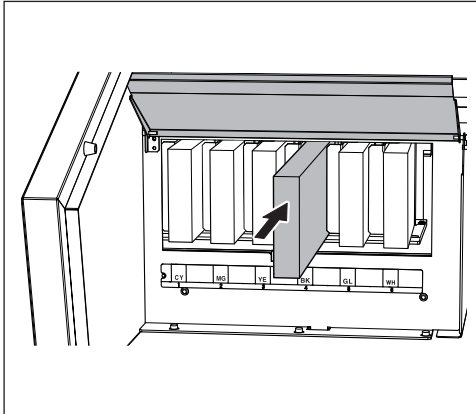

Pull out the empty ink cartridge and immediately insert the new one.

**POINT!**

- Keep the side with the arrow face up
- Insert and remove slowly, one at a time

5

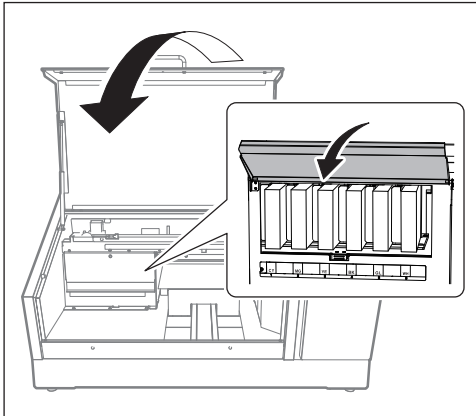

Close the ink cartridge cover.  
Close the front cover.

**IMPORTANT!**

**Important Notes on Replacing Cartridges**

- Make sure that the ink cartridge cover is always closed except when absolutely necessary, such as when you are replacing ink cartridges. The ink inside the cartridges will become hardened, and it may cause the printer to malfunction.
- Be sure to replace with an item of identical type.
- Never mix different types.
- Never leave the machine with an ink cartridge removed. The print heads may become clogged.
- Never insert or remove a partially used ink cartridge with undue force.
- Never remove an ink cartridge suddenly while the printer is in operation.

**⚠ WARNING**

**Never store ink, cleaning liquid, or discharged fluid in any of the following locations.**

- Any location exposed to open flame
- Any location where high temperature may occur
- Near bleach or any other such oxidizing agent or explosive material
- Any location within the reach of children

Doing so may lead to a fire. Accidental ingestion by children may pose a health hazard.

# Maintenance That Should Be Performed Daily

## Ink Cartridge Maintenance

Be sure to perform the following types of maintenance. The components in the ink have a tendency to precipitate. The deposits may harden and cause problems including printer malfunctions if left alone for an extended period of time, and this is especially true for the white ink.

- **Shake new ink cartridges 50 times (about 15 seconds) before installing them.**
- **Every day before starting work, remove the white ink cartridges, shake them 50 times (about 15 seconds), and then reinsert them.**

## Cleaning

**⚠ WARNING** Never use gasoline, alcohol, thinner, or any other flammable material. Doing so may cause a fire.

Wipe away any buildup of ink or grime that has adhered to the machine as part of daily cleaning. In particular, the flat table is likely to have a buildup of grime. Clean by wiping with a cloth moistened with neutral detergent diluted with water then wrung dry.

### POINT!

- This machine is a precision device, and is sensitive to dust and dirt. Perform cleaning on a daily basis.
- Never attempt to oil or lubricate the machine.

## Cleaning the Inside of the Machine

Frequently clean the inside of the machine using a vacuum cleaner or by wiping with a cloth moistened with water then wrung dry. If dust and dirt accumulate in the machine, they are likely to affix to printed materials.

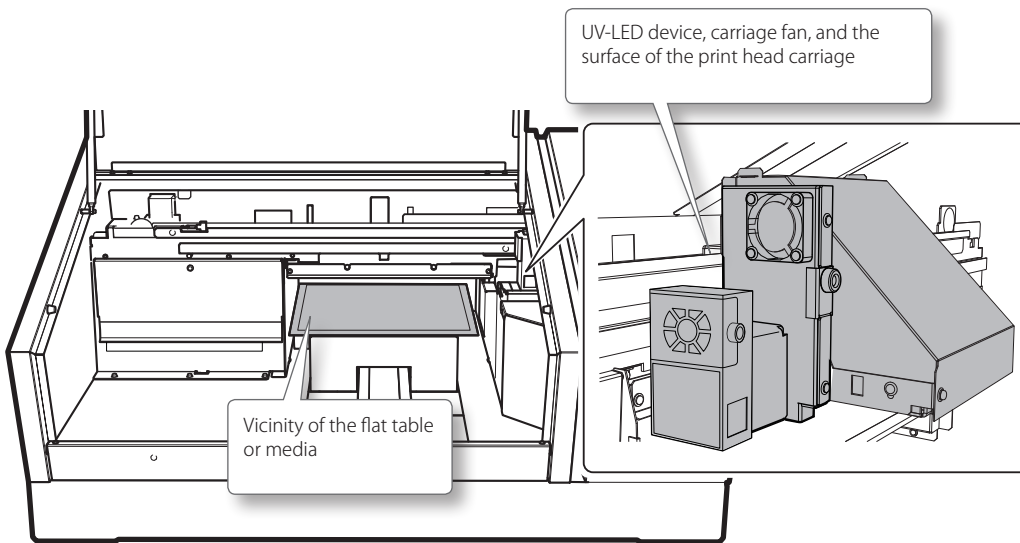



## About Care and Maintenance of the Print Heads

Care of the print heads is essential to ensuring optimal printing at all times. There are maintenance tasks that should be performed daily and those that should be performed periodically.

### Daily care and maintenance

#### Printing Tests and Normal Cleaning

Be sure to perform a printing test before and after daily operations. Also, perform this maintenance during daily operations as needed.

☞ P. 21, "Printing Tests and Normal Cleaning"

### Periodic care and maintenance

☞ P. 58, "Periodic Cleaning Maintenance"

**Note: The print heads are components that wear out. Periodic replacement is required, with the frequency of replacement depending on use. For information about purchasing replacements, contact your authorized Roland DG Corp. dealer or visit our website (<http://www.rolanddg.com/>).**

## Disposing of Discharged Fluid

```
CHECK
DRAIN BOTTLE
```

The drain bottle collects discharged fluid. Dispose of collected material before the bottle becomes full. The message shown in the figure appears when a certain amount of discharged fluid has collected in the bottle. Follow the procedure below to discard the discharged fluid.

### 1. Empty the bottle by discarding the discharged fluid.

① 

```
CHECK
DRAIN BOTTLE
```

When the message shown in the figure appears, press [ENTER].

② Press [MENU].

③ 

```
MENU
SUB MENU
```

Press [▼] several times until the screen shown on the left appears.

Press [▶].

Press [▲] twice.

④ 

```
SUB MENU
MAINTENANCE
```

Press [▶], then [▲].

⑤ 

```
MAINTENANCE
DRAIN BOTTLE
```

Press [ENTER].

6 OPEN PANEL  
COVER

When the figure shown on the left appears, open the panel cover.

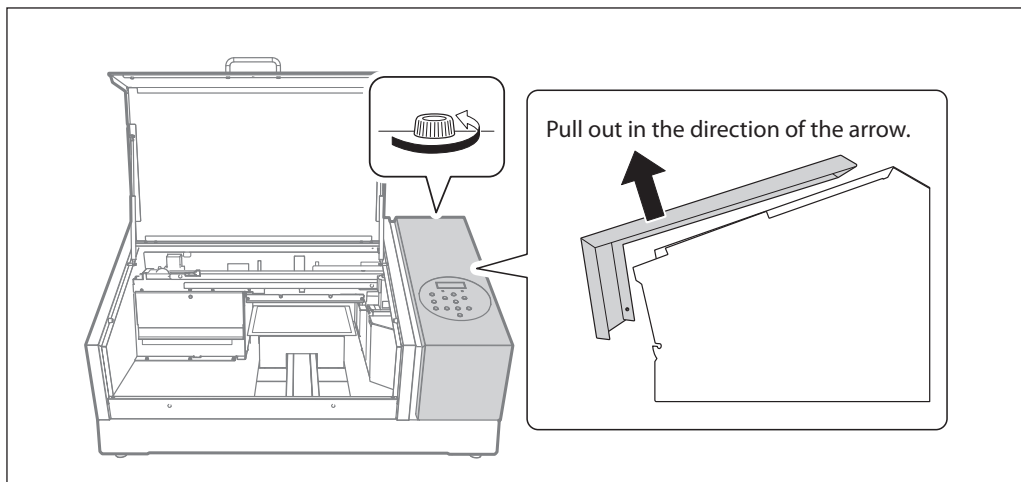

7 EMPTY  
DRAIN BOTTLE

When the screen shown on the left is displayed, remove the drain bottle and discard the discharged fluid.

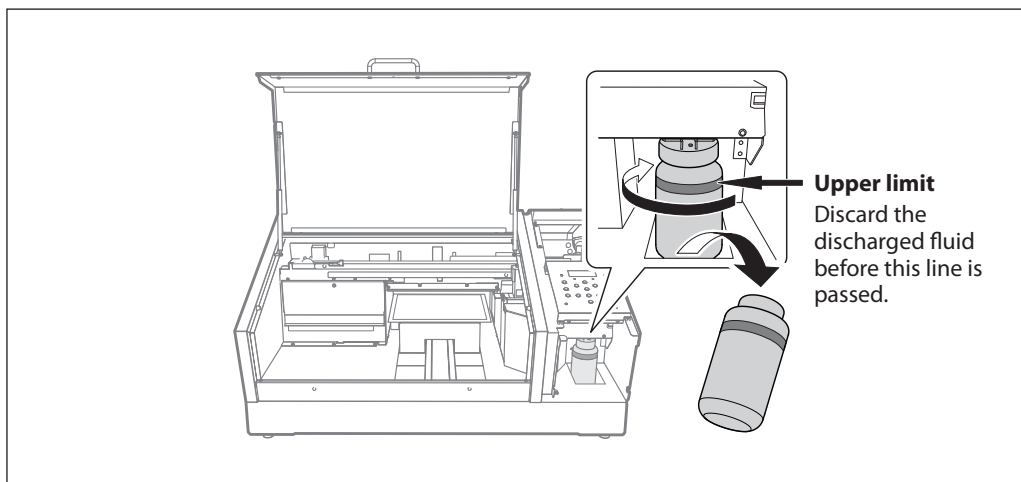

**⚠ CAUTION**

Before you detach the drain bottle, be sure to wait for the screen to display "EMPTY DRAIN BOTTLE."

Failing to follow this procedure may cause discharged fluid to flow out of the tube and spill onto your hands or the floor and cause a stain.

**⚠ WARNING**

Never place discharged fluid and ink near open flame.

Doing so may cause a fire.

**⚠ CAUTION**

To store discharged fluid temporarily, place it in the included drain bottle or in a durable sealed container such as a metal can or polyethylene tank, and cap the container tightly.

Any spillage or vapor leakage may cause a fire, odor, or physical distress.

**Do not store discharged fluid in a location where it is exposed to direct sunlight.**

When temporarily storing discharged fluid in the included drain bottle, do not store it in a location that is exposed to direct sunlight. The discharged fluid may harden, making the drain bottle unusable.

**Dispose of discharged fluid properly, in accordance with the laws in effect in your locale.**

Discharged fluid is flammable and contains toxic ingredients. Never attempt to incinerate discharged fluid or discard it with ordinary trash. Also, do not dispose of fluid in sewer systems, rivers, or streams. Doing so may have an adverse impact on the environment.

## 2. Attach the emptied drain bottle and reset the discharged-fluid count.

1

EMPTY  
DRAIN BOTTLE ↵

Attach the emptied drain bottle to the machine once more.  
Press [ENTER].

2

RESET DRAIN  
COUNTER ↵

Press [ENTER].

3

CLOSE PANEL  
COVER

When the figure shown on the left appears, close the panel cover.

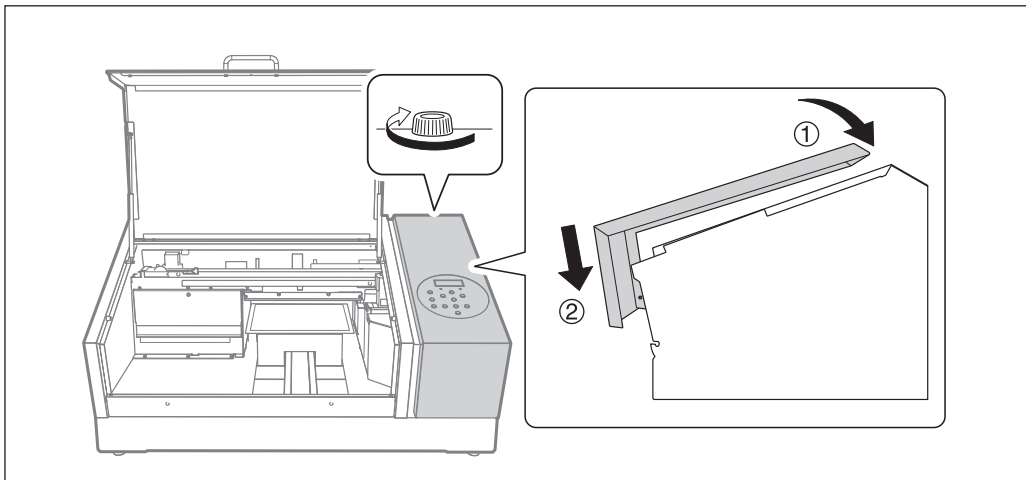

4

Press [MENU], then [←] to go back to the original screen.

# Periodic Cleaning Maintenance

## About Each Cleaning Method

There are several cleaning menus on this machine. Perform the appropriate type of cleaning in accordance with the cleaning period and machine condition.

<b>NORMAL CL.</b>	Perform normal cleaning when there is a dot drop-out in test prints. Be sure to do this in the following cases. ➤ <b>Before daily operations</b> ➤ <b>After daily operations</b>  Also, perform normal cleaning during daily operations as needed. ☞ P. 21, "Printing Tests and Normal Cleaning"
<b>MEDIUM CL.</b> <b>POWERFUL CL.</b>	If you cannot fix dot drop-out with normal cleaning, try medium cleaning. If medium cleaning does not fix the problem, perform powerful cleaning. ☞ P. 58, "Medium and Powerful Cleaning"
<b>Manual Cleaning</b>	Perform this cleaning every day when the machine's interior tends to be grimy due to the scattering of ink mist (this problem tends to occur when printing with some distance between the print heads and print surface). Even if it does not become very grimy, clean periodically as needed based on your usage (at least, once a month). ☞ P. 60, "Manual Cleaning"

## Medium and Powerful Cleaning

When normal cleaning (P. 21, "Printing Tests and Normal Cleaning") does not correct dot drop-out, perform the more powerful cleaning, a "medium cleaning," two or three times. If this still does not resolve the problem, try the even more forceful "powerful cleaning."

### POINT!

Medium cleaning consumes more ink than normal cleaning. Powerful cleaning consumes more ink than medium cleaning. Because the print heads are prone to damage if cleaned too frequently, do not perform cleaning more than necessary.

## Procedure

1 Press [FUNCTION].

2 

FUNCTION	◀◆
CLEANING	▶

Press [▶], then [▼].

3 

CLEANING	◀◆
MEDIUM CL.	▶

"MEDIUM CL."

Press [▶].

"POWERFUL CL."

Press [▼], then [▶].

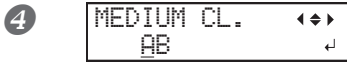

Press [←] or [→] to select the group of print heads that is not to be cleaned.

Press [▲] or [▼] to get rid of the group display.

Repeat this process to display only the group of print heads that requires cleaning.

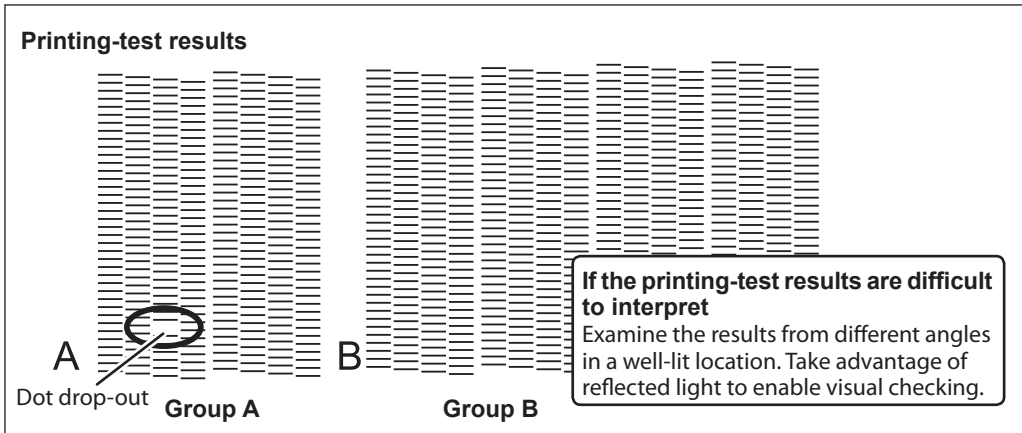

**"MEDIUM CL."**

The screen shown in the figure appears, and then cleaning starts.

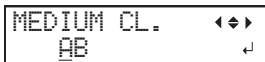

When finished, the screen shown in the figure appears again.

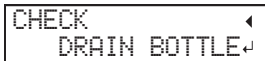

**"POWERFUL CL."**

**Check the drain bottle.**

If the amount of discharged fluid is near the upper-limit line, then remove the bottle, discard the collected fluid, and reattach the bottle. Press [ENTER].

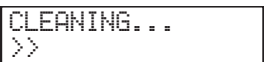

The screen shown in the figure appears, and then cleaning starts.

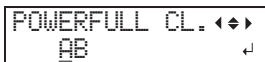

When finished, the screen shown in the figure appears again.

**6** Press [FUNCTION] to go back to the original screen.

***When powerful cleaning is not effective***

When dot drop-out does not improve after cleaning several times, perform "Manual Cleaning of Print Heads." Such cleaning can be effective when carried out periodically, according to the frequency of use.

☞ P. 60, "Manual Cleaning"

## Manual Cleaning

### When manual cleaning becomes necessary

#### When there is a lot of scattered ink mist and the inside of the machine is soiled

Perform this cleaning every day when frequently printing with the print heads at a distance from the print surface or when ink is emitted to locations that protrude from the print surface. If the scattered ink mist is allowed to harden, it may cause malfunctions.

#### Perform Manual Cleaning Once a Month or More

To maintain stable output conditions at all times, perform manual cleaning more than once a month.

#### We recommend manual cleaning when any of the following symptoms occurs

When any of the following symptoms occur and cannot be solved by automatic cleaning functions such as normal cleaning, perform manual cleaning.

Replacing the wipers is also an effective means of improving the symptoms.

☞ P. 69, "Replacing the Wipers"

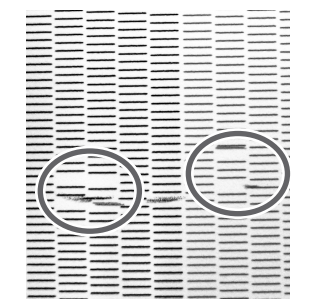
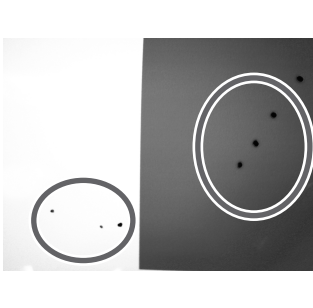
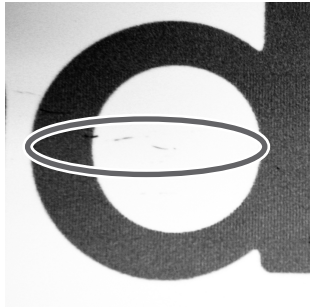
Dot drop-out	Ink drips	Dragging dirt
		
<p>Dust or other foreign matter adheres to the print heads and impedes correct ink discharge.</p>	<p>Ink accumulates on dirty areas around the print heads and drips onto the media.</p>	<p>Dirt accumulates on the area around the print heads and touches the media.</p>

- The frequency with which manual cleaning should be performed depends on the machine's use. For information about frequency of cleaning needed for your conditions of use, contact your authorized Roland DG Corp. dealer.
- In case you have run out of cleaning sticks and cleaning liquid for manual cleaning, you can find information about purchasing consumables through your authorized Roland DG Corp. dealer or by visiting our website (<http://www.rolanddg.com/>).
- The print heads are components that wear out. Periodic replacement is required, with the frequency of replacement depending on use. For information about purchasing replacements, contact your authorized Roland DG Corp. dealer or visit our website (<http://www.rolanddg.com/>).

**IMPORTANT!**

**Important notes on this procedure**

- Cleaning requires the cleaning liquid and cleaning sticks included with the printer, so have these items ready.
- Before performing this operation, remove any media.
- To prevent the heads from drying out, finish this procedure in 10 minutes or less. A warning beep sounds after 10 minutes.
- Never use any implements other than the included cleaning sticks. Cotton swabs or other lint-producing items may damage the heads. If you use up the cleaning sticks, contact your authorized Roland DG Corp. dealer.
- Use one cleaning stick per cleaning session. Reusing cleaning sticks will reduce the printing quality.
- Do not put a cleaning stick that has been used for cleaning into the cleaning liquid. Doing so will deteriorate the cleaning liquid.
- Never rub the nozzle surface of the heads.
- Stroke the sponges very gently, applying as little pressure as possible. Never rub, scrape, or crush them.

**If a warning beep sounds during cleaning**

A warning beep sounds 10 minutes after operation begins. Stop work, close the front cover, and then press [ENTER] to end the manual cleaning mode. After that, restart operation from the first procedure.

**⚠ CAUTION**

**Be sure to perform operations as specified by the instructions above, and never touch any area not specified in the instructions.**

Failure to observe this instruction may cause the machine to move suddenly, resulting in injury.

## 1. Change to the print-head manual-cleaning mode.

1 Remove any media. Close the front cover.

2 Press [MENU].

3 

Press [▼] several times until the screen shown on the left appears.

Press [▶].

Press [▲] twice.

4 

Press [▶].

5 MAINTENANCE ◀▶  
CLEANING ↵

Press [ENTER].

NOW PROCESSING..



OPEN FRONT  
COVER

The print-head carriage moves, and then the screen shown in the figure appears.

6 Open the front cover.

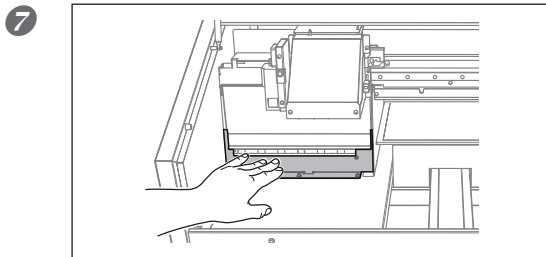

Touch the location shown in the figure (under the ink cartridge cover) to discharge any static electricity.

FINISHED? ↵

Preparations are complete when this screen appears.

## 2. Clean using a cleaning stick.

1 Moisten the cleaning stick with the cleaning liquid.

2 Clean in the sequence shown in the figure below.

Be especially careful to clean away any fibrous dust (lint).

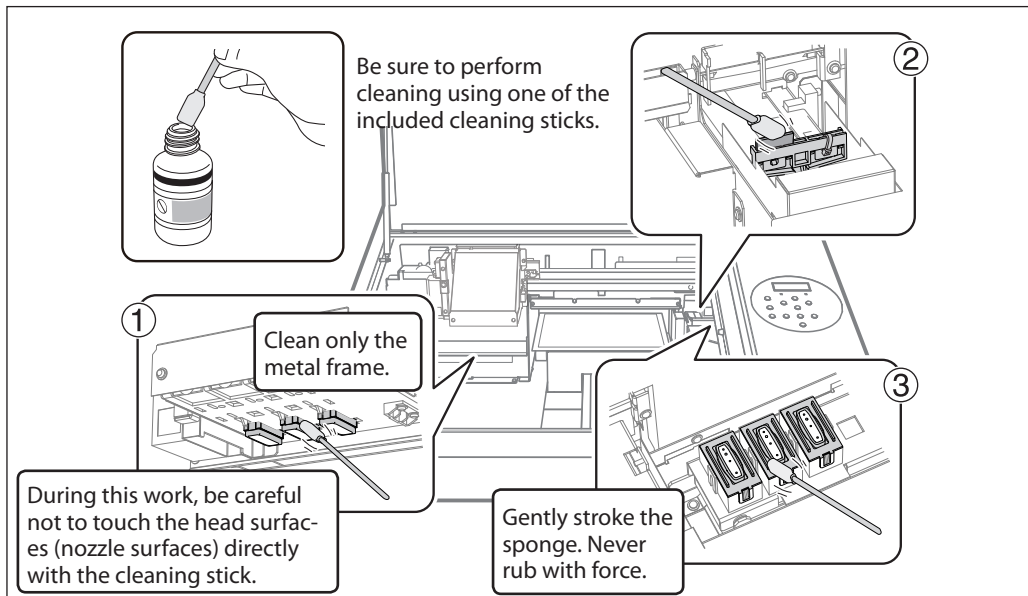



**IMPORTANT**

**Do not clean the irradiation surface (glass surface) of the UV irradiation device. Doing so may damage the UV irradiation device. For details on cleaning the irradiation surface of the UV irradiation device, contact your authorized Roland DG Corp. dealer.**

### 3. Exit manual cleaning mode.

① Close the front cover.

② Press [ENTER].

CLEANING...  
>>

The print-head carriage moves to the right side of the machine.



SETUP MEDIA

After quitting the manual cleaning mode, the screen returns to the figure as shown..

### 4. Perform a printing test to verify the results of the procedure.

**Perform a printing test to check the results.**

Perform cleaning using the machine's cleaning functions several times when necessary.

☞ P. 21, "Printing Tests and Normal Cleaning"

# When the White Ink Concentration Is Low

## Restoring the White Ink Concentration

Prolonged use of this machine may cause the concentration of the white ink to decrease. This is because the components in the white ink easily precipitate. The "CIRCULATE INK" function circulates the ink to eliminate white ink precipitation, which restores the white ink concentration. However, this procedure requires some ink to be discharged, so you should not perform this procedure frequently.

### Procedure

---

1 Press [MENU].

2 

MENU	◀◆
SUB MENU	▶

Press [▼] several times until the screen shown on the left appears.  
Press [▶].

3 

SUB MENU	◀◆
INK CONTROL	▶

Press [▲] several times until the screen shown on the left appears.  
Press [▶], then [▲].

4 

INK CONTROL	◀◆
CIRCULATE INK	▶

Press [▶].

5 

CIRCULATE INK	◀
CIR-DISCHARGE	▶

Press [ENTER].  
Ink circulation starts.

# When Dot Drop-out Cannot be Cleared Up

## When Dot Drop-Out Cannot Be Cleared Up for White or Gloss Ink

In this operation, all white and gloss ink within the printer is discharged and the interior is cleaned. Ink (white and gloss) is refilled after cleaning. This operation requires two SOL INK cleaning cartridges.

White ink tends to settle and may harden if left alone for a lengthy time. Therefore, abnormal ink emission including dot drop-out tends to occur more frequently than with other inks, even when using the cleaning function (Normal, Medium, or Powerful) or manual cleaning.

\* If you want to perform maintenance on inks other than white or gloss ink, see P. 66, "Cleaning All Print Heads".

### Important notes on this procedure

➤ **A large amount of ink will be discharged during this operation. Perform this operation when all procedures such as "Normal," "Medium," "Powerful," and "Manual" cleaning, and measures to improve ink emission flaws (such as dot drop-out) do not improve the symptoms.**

☞ P. 54, "Maintenance That Should Be Performed Daily"

☞ P. 58, "Medium and Powerful Cleaning"

☞ P. 60, "Manual Cleaning"

➤ **Be sure to use SOL INK cleaning cartridges. Use of any other type may result in breakdown.**

➤ **According to the procedure, fill with ink as soon as possible. Allowing the machine to stand without ink may damage the print heads.**

### Procedure

① Press [MENU].

② 

Press [▲] to display the figure on the left.  
Press [ENTER].

③ 

Discard the discharged fluid, and then reattach the drain bottle.  
Press [ENTER].

④ 

① Discard the discharged fluid and attach the emptied bottle.

5, 6 flashes



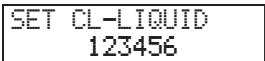

② Remove the ink cartridges from slots 5 and 6.

5, 6 flashes



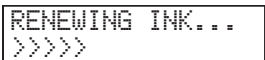

③ Insert SOL INK cleaning cartridges into slots 5 and 6.

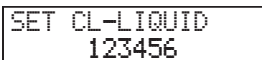
⑤ 

When the screen shown on the left appears, remove the SOL INK cartridges from slots 5 and 6.

5, 6 flashes



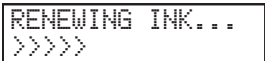

Tasks marked with ④ and ⑤ are performed as many times as indicated on the display.

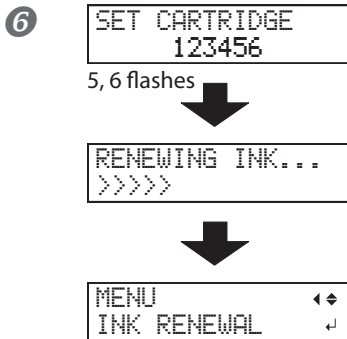

When the screen shown on the left appears, insert an ink cartridge in slots 5 and 6.

- ⑦ Close the ink cartridge cover and the front cover.
- ⑧ Press [MENU], then [←] to go back to the original screen.

## Cleaning All Print Heads

**In this operation, all ink within the printer is discharged and the interior is cleaned. Ink is refilled after cleaning.**

This operation requires six unused SOL INK cleaning cartridges (four for cleaning and two for refilling ink). Have these on hand before you start.

\* The effect on white ink and gloss ink is the same as P. 65, "When Dot Drop-Out Cannot Be Cleared Up for White or Gloss Ink". If you want to perform maintenance only on white ink and gloss ink, see page 66.

### Important notes on this procedure

- **All ink is discharged in this operation. Perform this operation when all procedures such as "Normal," "Medium," "Powerful," and "Manual" cleaning, and measures to improve ink emission flaws (such as dot drop-out) do not improve the symptoms.**
  - ☞ P. 54, "Maintenance That Should Be Performed Daily"
  - ☞ P. 58, "Medium and Powerful Cleaning"
  - ☞ P. 60, "Manual Cleaning"
- **Be sure to use SOL INK cleaning cartridges. Use of any other type may result in breakdown.**
- **Fill the machine with ink as soon as possible after cleaning is finished. Allowing the machine to stand without ink may damage the print heads.**

### Procedure

- ① **Discard the discharged fluid.**  
Perform operations starting from P. 55, "Disposing of Discharged Fluid" 1. - ② to dispose of the discharged fluid. The following operations will discharge large amounts of fluid. If you do not empty the drain bottle, the discharged fluid may overflow.

- ② **Press [MENU].**

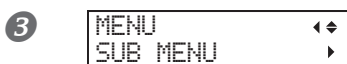

Press [▼] several times until the screen shown on the left appears.  
Press [▶].

4 

Press [▲] several times until the screen shown on the left appears.

Press [▶].

Press [▼] twice.

5 

Press [ENTER].

6 

Make sure the cleaning liquid is ready.

Press [ENTER].

7 

Make sure the drain bottle is empty, and then press [ENTER].

If it is not empty, redo from Step 1.

Be sure to discard the discharged ink.

8 **Next, follow the on-screen instructions to carry out the operations.**

After cleaning has finished, the sub power switches off.

9 **Start filling ink.**

See "First Step Guide" and promptly fill with ink. When filling with ink, you use (two) SOL INK cleaning cartridges again.

### Cleaning of the head surface as an emergency measure

When dot drop-out and/or dot deflection is not improved even if cleaning is performed several times, you can clean the head surface as an emergency measure. Since the head surface (nozzle surface) is an extremely delicate mechanism, make sure to perform the operation carefully and deliberately. This procedure is an emergency measure. Depending on symptoms, it may damage normal areas and cause symptoms to worsen. If you have any questions, contact your authorized Roland DG Corp. dealer.

#### Procedure

- ❶ Perform Step 1. on page 62, "Manual Cleaning."
- ❷ Apply a large amount of cleaning liquid to the cleaning stick.
- ❸ Very gently touch the cleaning stick against the head surface (nozzle surface).

Very softly press the cleaning stick against the print head so that cleaning liquid soaks into the head nozzle. Never rub the stick or press it forcefully against the head surface.

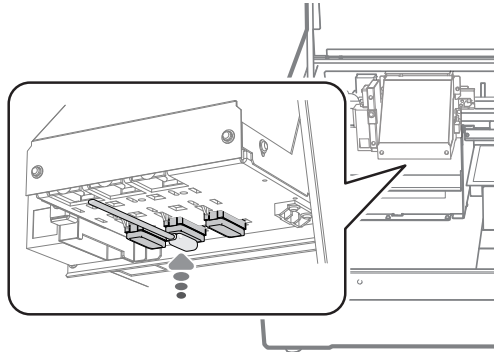

- ❹ Perform Steps 3. and 4. on page 64, "Manual Cleaning."

# Replacing Consumable Parts

## Replacing the Wipers

```
TIME FOR  
WIPER REPLACE↵
```

The wiper is a component that is used for cleaning the print heads. When the screen displays a message like the one shown below, it is time to replace the item. Replace them with new items.

For information about purchasing wipers, contact your authorized Roland DG Corp. dealer.

### *When a warning beep sounds during wiper replacement*

A warning beep sounds 10 minutes after operation begins. Stop work and close the front cover. Press [ENTER] to exit the wiper replacement menu. After that, restart operation from the first procedure.

### **⚠ CAUTION**

**Be sure to perform operations as specified by the instructions, and never touch any area not specified in the instructions.**

Failure to observe this instruction may cause the machine to move suddenly, resulting in injury.

## 1. Enter the wiper replacement menu.

1

```
TIME FOR  
WIPER REPLACE↵
```

When the message shown in the figure appears, press [ENTER].

2

Remove any media.

3

Press [MENU].

4

```
MENU      ◀▶  
SUB MENU  ▶
```

Press [▼] several times until the screen shown on the left appears.

Press [▶].

Press [▲] twice.

5

```
SUB MENU  ◀▶  
MAINTENANCE ▶
```

Press [▶], then [▼].

6

```
MAINTENANCE ◀▶  
REPLACE WIPER ↵
```

Press [ENTER].

```
NOW PROCESSING..
```



```
OPEN FRONT  
COVER
```

The print-head carriage moves, and then the screen shown in the figure appears.

7

Open the front cover.

8

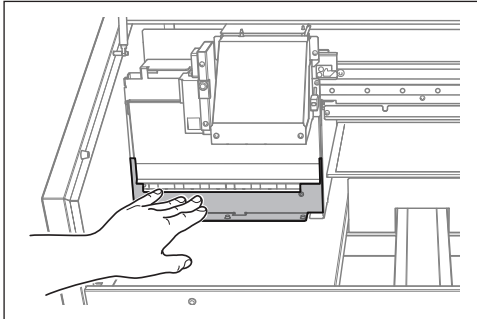

Touch the location shown in the figure (under the ink cartridge cover) to discharge any static electricity.

9

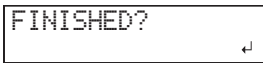

Preparations are complete when this screen appears.

## 2. Replace the wipers.

1

**Detach the old wipers.**

Disconnect the hooks, and then pull the wipers up and out.

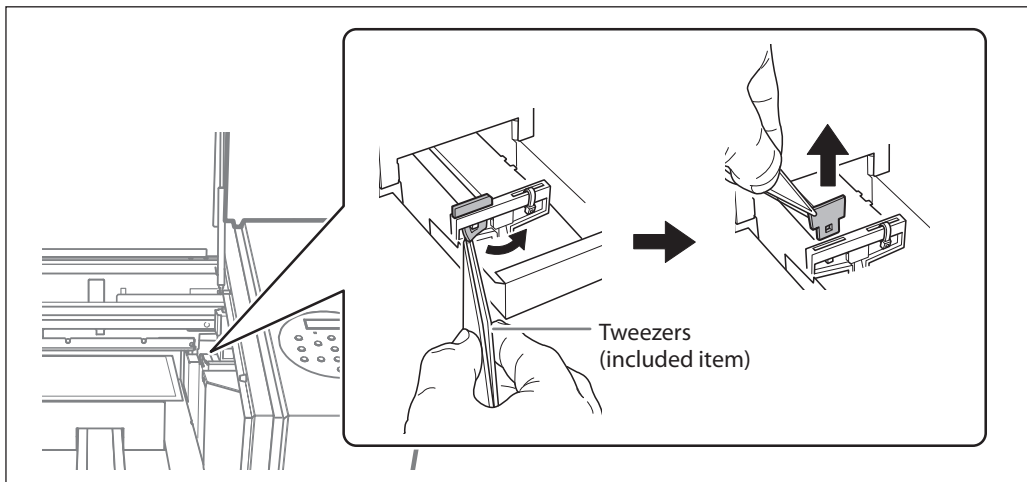

2

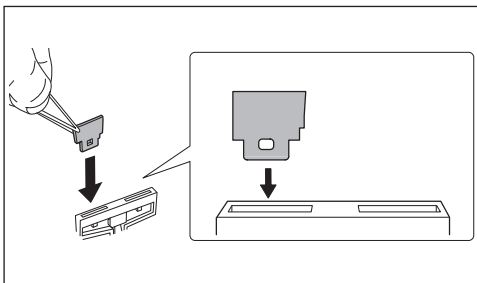

**Insert the new wipers.**

Insert the wipers with the orientation shown in the figure.



3

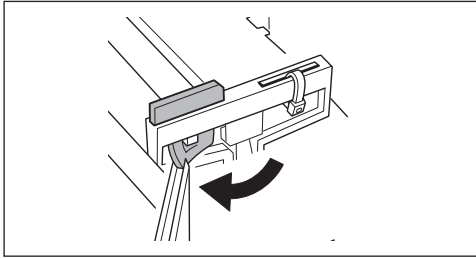

Attach the wiper to the hook.

### 3. Exit the wiper replacement menu.

1 Close the front cover.

2

FINISHED? ↵

Press [ENTER].

CLEANING...  
>>



SETUP MEDIA

After the process to quit the wiper replacement mode, the screen shown in the figure appears.

## Replacing the Filter

TIME FOR  
FILTER REPLACE ↵

This section explains how to replace the filter used for the mist fan that adjusts the scattering of ink mist. When the screen displays a message like the one shown below, it is time to replace the item. Replace them with new items. For information about purchasing filters, contact your authorized Roland DG Corp. dealer.

### *When a warning beep sounds during filter replacement*

A warning beep sounds 10 minutes after operation begins. Stop work and close the front cover. Press [ENTER] to exit the filter replacement menu. After that, restart operation from the first procedure.

### **⚠ CAUTION**

**Be sure to perform operations as specified by the instructions, and never touch any area not specified in the instructions.**

Failure to observe this instruction may cause the machine to move suddenly, resulting in injury.

## 1. Enter the filter replacement menu.

1

TIME FOR  
FILTER REPLACE ↵

When the message shown in the figure appears, press [ENTER].

2

Remove any media.

3

Press [MENU].

4

MENU            ◀▶  
SUB MENU       ▶

Press [▼] several times until the screen shown on the left appears.

Press [▶].

Press [▲] twice.

5

SUB MENU       ◀▶  
MAINTENANCE ▶

Press [▶].

Press [▼] twice.

6

MAINTENANCE ◀▶  
REPLACE FILTER ↵

Press [ENTER].

REPLACE REAR  
FAN FILTER ↵

Preparations are complete when this screen appears.

## 2. Replace the filter.

1

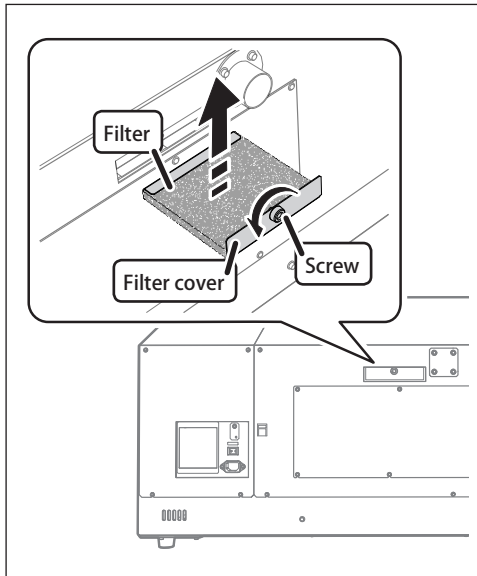

### Replace rear mist fan's filter.

When replacing, wipe away any buildup of ink around the fan module with a cloth.

2

Press [ENTER].

NOW PROCESSING..



OPEN FRONT  
COVER

The print-head carriage moves, and then the screen shown in the figure appears.

**Open the front cover.**

REPLACE CARRIAGE  
FAN FILTER ↵

Preparations are complete when this screen appears.

3

Replace carriage mist fan's filter.

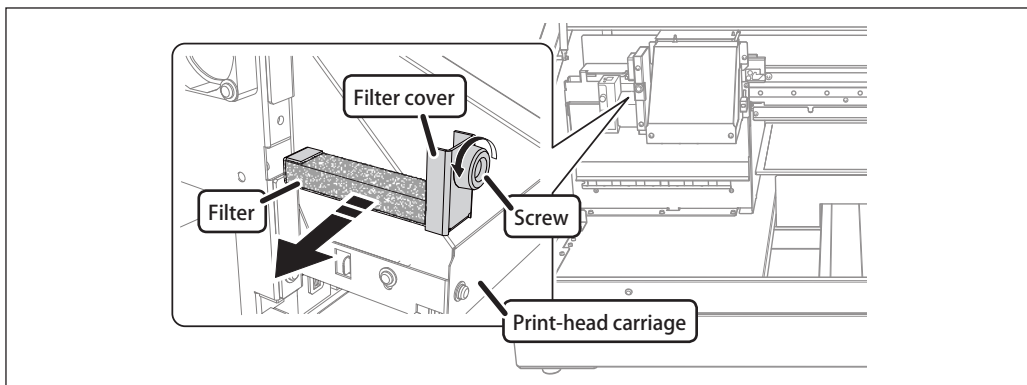

When replacing, wipe away any buildup of ink around the fan module with a cloth.

### 3. Quit the filter replacement menu.

---

- 1 Close the front cover.
- 2 Press [ENTER].

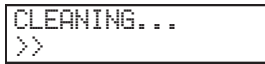

A rectangular box representing a screen display with the text "CLEANING..." on the first line and ">>" on the second line.



A rectangular box representing a screen display with the text "SETUP MEDIA" on a single line.

After quitting the filter replacement menu, the screen returns to the figure as shown.

# When Moving the Unit

## Procedure from Preparing to Move to Reinstallation

To move the machine, you must completely drain all ink inside the machine and secure the print heads in place with packing materials to protect them. Attempting to move the machine without first doing this may result in damage to internal components due to leaking ink or damage to the heads.

This operation requires six unused SOL INK cleaning cartridges (four for cleaning and two for refilling ink). Have these on hand before you start.

### ***Important notes on moving***

- Be sure to use SOL INK cleaning cartridges. Use of any other type may result in breakdown.
- Once the preparations for moving are complete, move the machine and fill it with ink with as little delay as possible. Allowing the machine to stand without ink may damage the print heads.
- When moving the machine, keep it at a temperature between 5 to 40°C (41 to 104°F) and at relative humidity between 20 to 80% (with no condensation). Failure to do so may result in breakdown.
- Handle the machine with care when moving it, keeping it level (not tilted at an angle) and preventing it from striking other objects.

### **Procedure**

- 1 Clean the print heads.**  
Perform steps on .
- 2 If the drain bottle and the panel cover have been removed, attach them.**
- 3 Remove the stored retainers.**

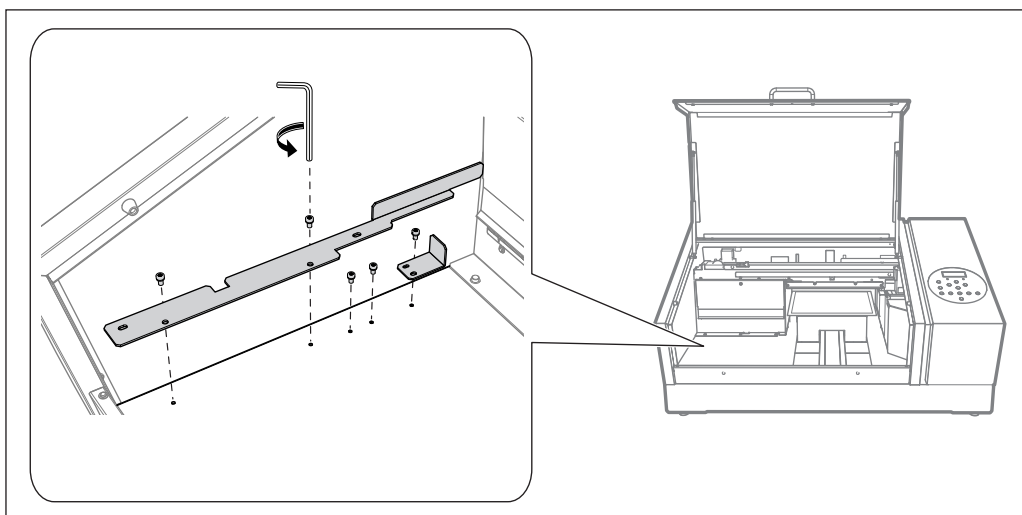

- 4 **Secure the print heads and the flat table in place.**

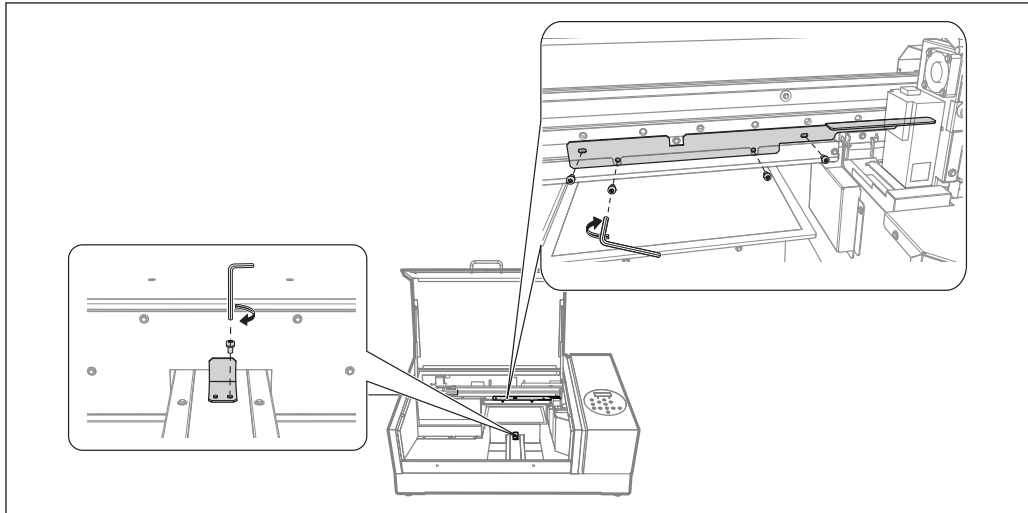

The machine is now ready to be moved.

- 5 **Move the machine as soon as possible.**
- 6 **After moving the machine, immediately reinstall it and fill it with ink.**  
See "First Step Guide" and promptly fill with ink. When filling the machine with ink, use (two) SOL INK cleaning cartridges again.

# ***Chapter 4***

## ***Appendix***

---

Read This Section Whenever You Face a Problem (FAQ) .....	78
Printer Does Not Run .....	78
Attractive Printing Is Impossible .....	80
The Print Heads Do Not Move.....	82
Handling Messages and Error Messages .....	83
A Message Appears.....	83
An Error Message Appears .....	85
Main Specifications .....	87
Dimensional Drawings.....	87
Locations of Power Rating and Serial Number Labels .....	88
Specification Table.....	89

# Read This Section Whenever You Face a Problem (FAQ)

## Printer Does Not Run

### The printer unit does not run

#### Is the power switched on?

Switch on the printer's main power, and then press the sub power switch and make sure the sub power switch lights.

☞ P. 6, "Main Menu"

#### Is [SETUP] lit?

If [SETUP] is not lit, the printer cannot print. Configure the settings all the way to the setting of the print area, close the front cover, and then press [SETUP].

☞ P. 18, "Specify the Print Area Directly"

☞ P. 19, "Specifying the Print Area from the Print Center Position"

#### Are any covers open?

Close the front cover and the panel cover.

#### Is the top menu displayed?

Top menu

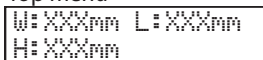

```
W:XXXXn L:XXXXn
H:XXXXn
```

If the top menu is not displayed, printing will not start even when data is sent from the computer. To go to the top menu, press [MENU], and then press [←].

#### Is [PAUSE] lit?

When [PAUSE] is lit, operation is paused. To resume, press [PAUSE]. [PAUSE] turns off and printing resumes.

☞ P. 28, "Pausing or Canceling Printing"

#### Has the ink run out?



```
1 2■■ 3■■ 4■■
5■■ 6■■
```

When data is sent while the screen shown in the figure is displayed, a message appears and a warning beep sounds. At the same time, operation pauses. When the ink cartridge is replaced with a new one, printing starts.

☞ P. 52, "How to Replace Ink Cartridges"

#### Is a message displayed on the screen?

☞ P. 83, "A Message Appears"

#### Are the cables connected?

Connect the cables securely.

☞ "First Step Guide"



### Is the Activity LED lit?

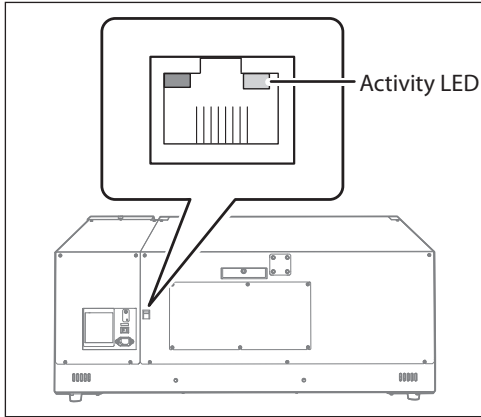

If the Activity LED for the Ethernet connector is not lit, the network connection has not been made correctly. Check whether the network routing is appropriate. Try connecting the computer and the machine to the same hub, or connecting them directly using a crossover cable. If this makes it possible to perform printing, it means the problem is in the network itself.

### Are the network settings correct?

If output is not possible even though the Activity LED is on, make sure the IP address and other settings are correct. The settings on both the machine and the computer must be appropriate. Redo the settings by checking that the IP address does not conflict with the IP address for another device on the network, that the port setting for the RIP & PRINT MANAGEMENT SOFTWARE specifies the IP address set on the machine, that the settings have no typing errors, and for other such problems.

- ☞ P. 47, "Viewing Information about the System of This Machine"
- ☞ "First Step Guide"

### Did the RIP & PRINT MANAGEMENT SOFTWARE exit abnormally?

Make sure the RIP & PRINT MANAGEMENT SOFTWARE is running correctly, and then switch the sub power switch off and back on.

- ☞ "Roland VersaWorks Dual Installation Guide"

### Is the temperature of the room too low?

Use the machine in an environment where the temperature is 20 to 32°C (68 to 90°F).

---

## The flat table does not move

---

### Is something stuck in one of the movable axes (X, Y, or Z)?

Check whether something has become caught and is interfering with operation.

### Are any covers open?

Close the front cover and panel cover during startup and printing. In the interest of safety, the flat table does not move if any cover is open during startup or printing.

---

## The head gap sensor does not detect the media

---

### Is something covering the head gap sensor or has it attracted dust?

Check whether something is interfering with the head gap sensor's detection.

## Attractive Printing Is Impossible

---

### Printed results are coarse or contain horizontal stripes

---

#### Do the print heads show dot drop-out?

Carry out a printing test and make sure no dot drop-out occurs. If dot drop-out is present, perform cleaning of the print heads.

- ☞ P. 21, "Printing Tests and Normal Cleaning"
- ☞ P. 58, "Medium and Powerful Cleaning"
- ☞ P. 65, "When Dot Drop-Out Cannot Be Cleared Up for White or Gloss Ink"
- ☞ P. 66, "Cleaning All Print Heads"

#### Is the print mode suitable?

Try an appropriate print mode. Specific combinations of media and print mode may cause the colors to be uneven, and results may also vary greatly depending on the settings of your RIP & PRINT MANAGEMENT SOFTWARE (such as the color-profile selection). Select settings appropriate for the media you are using.

#### Is the printer installed in a level and stable location?

Never install the machine in a location where it is tilted or where it may wobble or experience vibration. These factors may lead to dot drop-out or reduced printing quality.

#### Is the printer installed in a location that is not exposed to direct sunlight?

Never install the machine in a location that is exposed to direct sunlight. Doing so may result in dot drop-out or reduced printing quality and may even result in malfunctions.

#### Is the media loaded and set up correctly?

If the media is not loaded correctly, printing may be adversely affected. Make sure the media is loaded and set up correctly.

- ☞ P. 11, "How to Secure the Media"
- ☞ P. 13, "Set Height Position of Media (Automatic)"
- ☞ P. 15, "Set Height Position of Media (Manual)"
- ☞ P. 18, "Specify the Print Area Directly"
- ☞ P. 19, "Specifying the Print Area from the Print Center Position"

---

### Colors are unstable or uneven

---

#### Did you shake the ink cartridges before installing them?

Shake new ink cartridges 50 times (about 15 seconds) before you install them.

#### Has the printer been used for a long time?

If, during use, the white ink concentration becomes low, use the [CIRCULATE INK] function.

- ☞ P. 64, "Restoring the White Ink Concentration"

#### Was printing paused partway through?

When printing is paused, the coloring at the seam may be altered when printing resumes. Avoid pausing printing. With the factory default settings, printing pauses when an ink cartridge becomes empty. Printing may also pause when data is not sent from the computer quickly enough. We recommend not performing any other tasks with the computer while printing is in progress.

**Is the printer installed in a level and stable location?**

Never install the machine in a location where it is tilted or where it may wobble or experience vibration. These factors may lead to dot drop-out or reduced printing quality.

**Are the operating parameters set to appropriate values?**

Depending on the settings for the [PERIODIC CL.] menu, uneven colors may occur. If the setting has been changed, try restoring it to its default value.

☞ P. 39, "Preventing Soiling of the Media and Dot Drop-Out"

**Is the printer being used in a location subject to severe changes in the operating environment?**

Large fluctuations in temperature or humidity while printing is in progress may cause the colors to change partway through printing. When printing, use the machine in a location where the temperature and humidity are stable.

**Are the settings for the [PRESET] menu item appropriate?**

If the settings selected with the [PRESET] menu item are not suitable for the type of media, printing may be adversely affected. Choose settings optimized to the media you are using.

☞ P. 32, "Fully Utilizing the Preset Function"

---

**The media becomes soiled when printed**

---

**Are the print heads dirty?**

The following may cause ink to drip on the media during printing:

- Buildup of fibrous dust (lint) around the heads
- Ink transferred to the heads due to rubbing against the media

If this happens, perform manual cleaning. We recommend carrying out periodic cleaning of the heads.

☞ P. 60, "Manual Cleaning"

- Humidity is too low.

Use this machine in a 35-80% RH (non-condensation) environment.

## The Print Heads Do Not Move

If the print-head carriage stops anywhere other than the home position (the right side of the main unit), take action immediately to prevent the heads from drying out.

### What to Do First

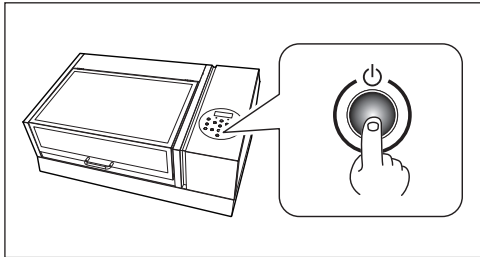

Switch the sub power off, then back on again.

If the print-head carriage moves to the home position (the right side of the main unit), the operation has ended successfully.

### If the Print Heads Still Do Not Move

Try switching off the main power, then switching on the main power again, followed by the sub power.

### If the Print Heads Still Do Not Move

If the heads still do not move, carry out the following emergency response measure, and then contact your authorized Roland DG Corp. dealer.

### Procedure

1 Turn off the main power switch.

2 Open the front cover.

3

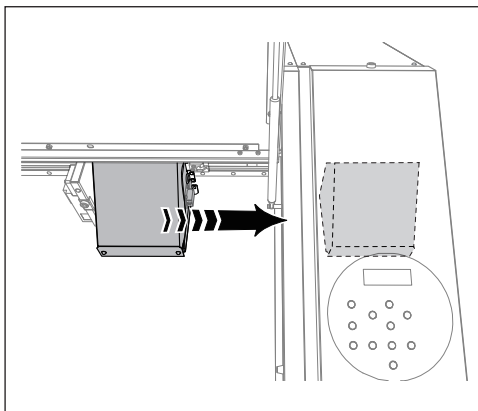

**Gently move the print-head carriage to the home position by hand.**

Stop when you hear the print-head carriage click into place.

4 Close the front cover.

# Handling Messages and Error Messages

## A Message Appears

These are the main messages that appear on the machine's display to prompt correct operation. They do not indicate any errors. Follow the prompts and take action accordingly.

---

### [ 1 2 ■ 3 ■ 4 ■ 5 ■ 6 ■ ]

---

Only a small amount of ink remains. Replace the ink cartridge indicated by the flashing number with a new cartridge.

---

### [PRESS THE POWER KEY TO CLEAN]

---

This message appears when the machine has been unused for about one month. Turn on the sub power once a month.

☞ P. 50, "Introduction: About Maintenance"

---

### [CIRCULATING INK]

---

White ink is being circulated inside the machine. This action is automatically performed to clear the white ink precipitation. Wait until the displayed message changes.

---

### [SET CARTRIDGE]

---

Insert the ink cartridge indicated by the flashing number. These messages appear during ink cartridge replacement and in similar situations.

---

### [REMOVE CARTRIDGE]

---

Remove the ink cartridge indicated by the flashing number. These messages appear during ink cartridge replacement and in similar situations.

---

### [SET CL-LIQUID]

---

Insert the SOL INK cleaning cartridge into the slot(s) indicated by the flashing number. This message appears at times such as during head cleaning.

---

### [REMOVE CL-LIQUID]

---

Remove the SOL INK cleaning cartridge indicated by the flashing number. This message appears at times such as during head cleaning.

---

### [CLOSE THE COVER (FRONT COVER or PANEL COVER) DRY-UP MAY DAMAGE THE HEAD]

---

Close either the front cover and panel cover, or both. If the message is left displayed, the print heads may dry out, resulting in malfunction.

---

### [SETUP MEDIA]

---

Reload the media and press [SETUP]. This message appears when an attempt to perform a printing test was made while no media was loaded.

---

### [INSTALL DRAIN BOTTLE]

---

Check whether the drain bottle is installed. Install the drain bottle, and then press [ENTER].

---

### [CHECK DRAIN BOTTLE]

---

This appears when a certain amount of discharged fluid collects in the drain bottle. To clear the message, press [ENTER]. If this screen appears, go to the [DRAIN BOTTLE] menu and discard the discharged fluid in the bottle.

☞ P. 55, "Disposing of Discharged Fluid"

---

### [TIME FOR MAINTENANCE]

---

It is time to perform manual cleaning. After verifying the message, press [ENTER].

☞ P. 60, "Manual Cleaning"

---

### [TIME FOR WIPER REPLACE]

---

It is time to replace the wipers. After verifying the message, press [ENTER].

☞ P. 69, "Replacing the Wipers"

---

### [TIME FOR FILTER REPLACE]

---

It is time to replace the filter. After verifying the message, press [ENTER].

☞ P. 72, "Replacing the Filter"

---

### [READJUST TABLE HEIGHT]

---

#### **The Height of the Media was Automatically Re-set, and Printing was Finished.**

During printing, the media came into contact with the head gap sensor, but [CLEARANCE MODE] is set to [RE-ADJ], so the media height was reset automatically and printing was performed to completion. Press any key (except the sub power switch) on the operation panel to make the message disappear.

☞ P. 13, "Set Height Position of Media (Automatic)"

☞ P. 18, "Specify the Print Area Directly"

☞ P. 19, "Specifying the Print Area from the Print Center Position"

☞ P. 38, "Performing Automatic Adjustment to Continue Printing Even When the Media Comes into Contact with the Head Gap Sensor During Printing"

## An Error Message Appears

This section describes the error messages that may appear on the machine's display and how to take action to remedy the problem. If the action described here does not correct the problem or if an error message not described here appears, contact your authorized Roland DG Corp. dealer.

---

### [AREA TOO SMALL CONTINUE?]

---

#### The size of the data is larger than the print area of the loaded media

To continue printing without correcting this, press [ENTER]. The portion extending beyond the print area will not be printed. To stop printing, stop sending data from the computer and hold down [SETUP] for one second or longer. Make the print area wider by replacing the media with a larger piece of media or by changing the position of the media, and then send the data again.

---

### [PRINT AREA TOO SMALL]

---

#### The size of the test print is larger than the print area of the loaded media.

Press any key on the operation panel to go back to the main menu. Make the print area wider by replacing the media with a larger piece of media or by changing the position of the media, and then send the data again.

---

### [CANCELED FOR TABLE HEIGHT]

---

#### The media was detected in a position (at a height) at which it hits the print heads.

Remove the media or change its position. Press any key (except the sub power switch) on the operation panel to make the message disappear. If the setup of the media has been completed, the setup is canceled. Redo the setup.

- ☞ P. 11, "How to Secure the Media"
- ☞ P. 13, "Set Height Position of Media (Automatic)"
- ☞ P. 15, "Set Height Position of Media (Manual)"
- ☞ P. 18, "Specify the Print Area Directly"
- ☞ P. 19, "Specifying the Print Area from the Print Center Position"
- ☞ P. 38, "Performing Automatic Adjustment to Continue Printing Even When the Media Comes into Contact with the Head Gap Sensor During Printing"

---

### [TEMPERATURE IS TOO HIGH \*\*°C]

---

#### The temperature of the location where the machine is installed has risen above the ambient temperature at which the machine can operate.

Operation cannot be continued. Turn off the sub power. The displayed temperature is the current ambient temperature of the installation location. Bring the installed location to a temperature at which operation is possible (20 to 32°C or 68 to 90°F) and allow the machine to come to room temperature, and then turn on the power.

---

### [SERVICE CALL xxxx]

---

#### An unrecoverable error occurred or part replacement that must be performed by a service technician is required.

Note the number displayed on the display screen, and then switch off the sub power. After you switch off the power, inform your authorized Roland DG Corporation dealer or call center of the number that appeared on the display.

---

### [TEMPERATURE IS TOO LOW \*\*°C]

---

**The temperature of the location where the machine is installed has fallen below the ambient temperature at which the machine can operate.**

Operation cannot be continued. Turn off the sub power. The displayed temperature is the current ambient temperature of the installation location. Bring the installed location to a temperature at which operation is possible (20 to 32°C or 68 to 90°F) and allow the machine to come to room temperature, and then turn on the power.

---

### [DATA ERROR CANCELING...]

---

**Printing was stopped because a problem was found in the received data.**

Operation cannot be continued. Check whether there is an error in the data. Check for a problem with the connector cable or the computer, and then redo the operations starting from the setup of the media.

---

### [WRONG CARTRIDGE]

---

**A cartridge that cannot be used was installed**

Remove the ink cartridge to clear the error. Use an ink cartridge of the specified type.

---

### [WRONG HEAD IS INSTALLED]

---

**An unusable print head has been installed.**

Turn off the sub power. After you switch off the power, contact your authorized Roland DG Corp. dealer.

---

### [AVOIDING DRY-UP TURN POWER OFF]

---

**The print heads were forced to the home position to prevent them from drying out.**

Operation cannot be continued. Switch the sub power off, then back on. Opening the front cover while printing is in progress causes an emergency stop. Never allow the print heads to remain in this state.

---

### [MOTOR ERROR TURN POWER OFF]

---

**A motor error occurred.**

Operation cannot be continued. Turn off the sub power. Next, eliminate the cause of the error, and then immediately switch on the sub power. If the machine is left with the error uncorrected, the print heads may dry out and become damaged. This error may be caused by the media being set incorrectly.

---



# Main Specifications

## Dimensional Drawings

### Outer dimensions

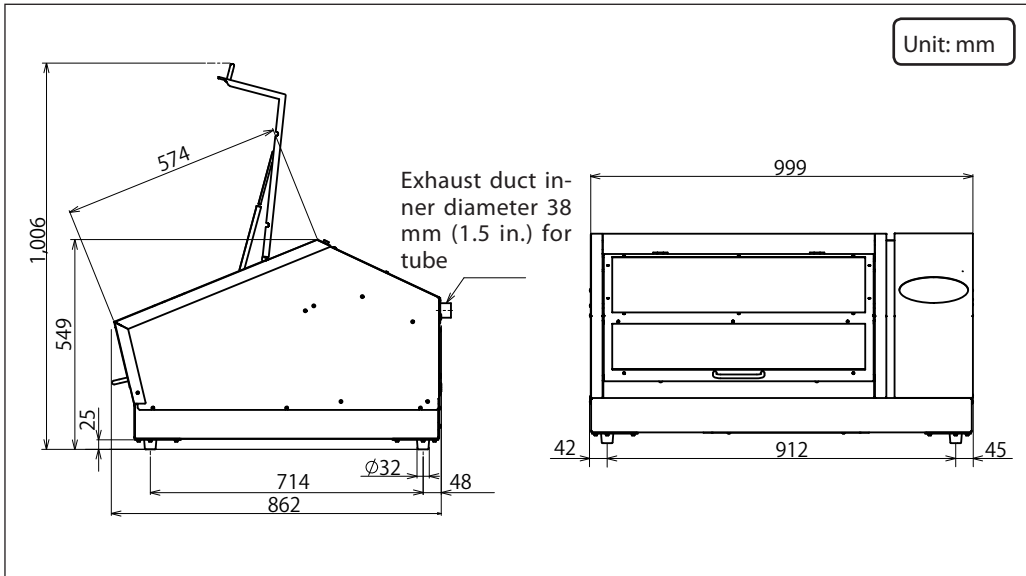

### Flat Table Dimensions

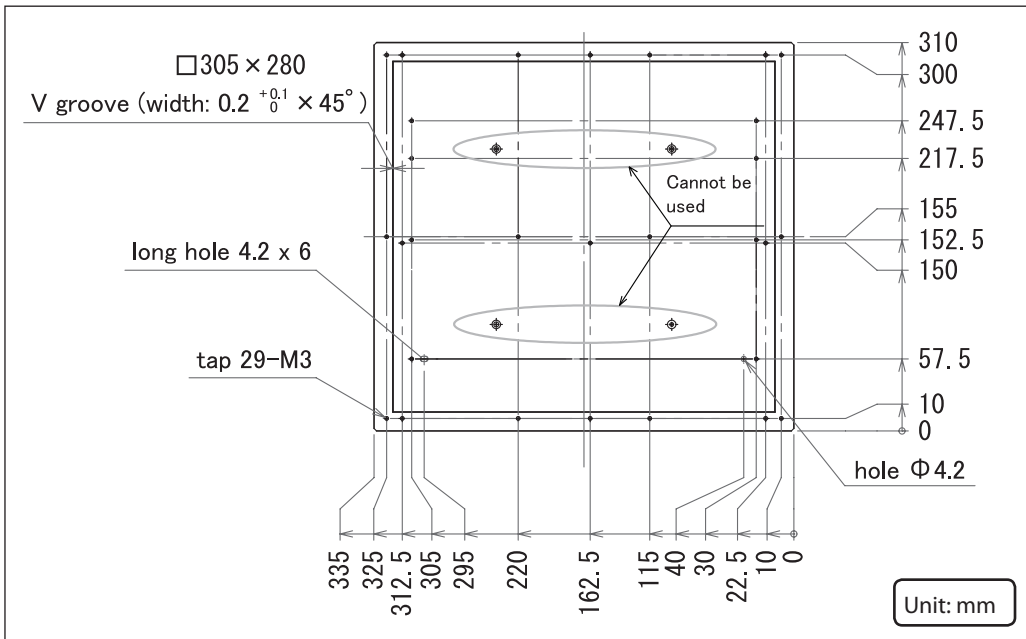

## Locations of Power Rating and Serial Number Labels

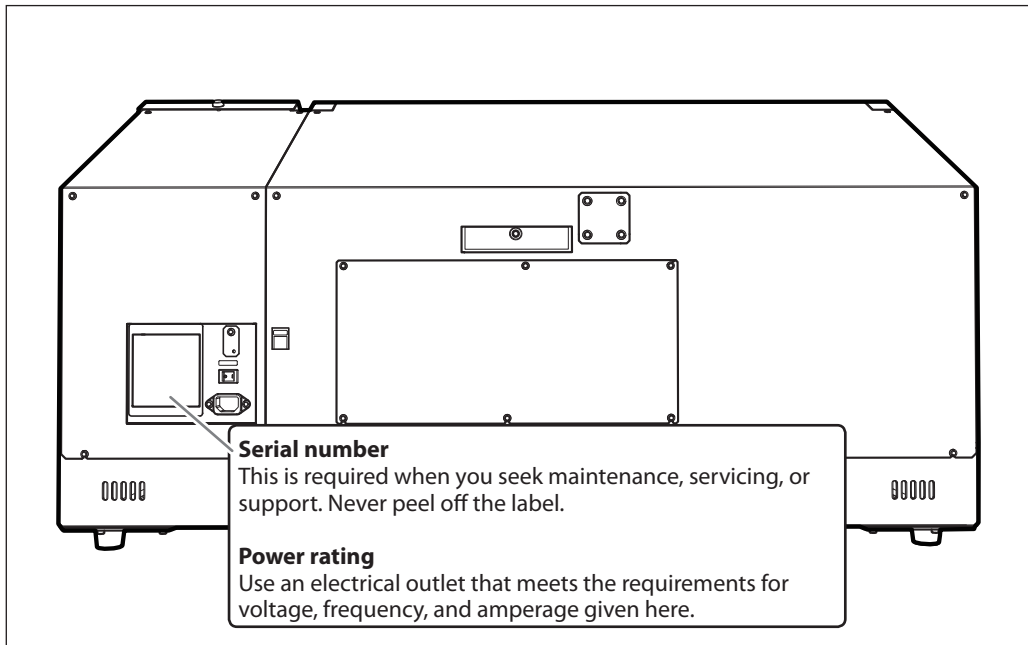

## Specification Table

		LEF-12i
<b>Printing technology</b>		Piezoelectric inkjet
<b>Acceptable media</b>	<b>Width</b>	Maximum 335 mm (13.2 in.)
	<b>Length</b>	Maximum 310 mm (12.2 in.)
	<b>Thickness</b>	Maximum 100 mm (3.94 in.)
	<b>Weight</b>	Maximum 5 kg (11 lb.)
<b>Maximum printing width/printing length</b>		Maximum 305 (width) x 280 (length) mm (12 x 11 in)
<b>Ink cartridges</b>	<b>Types</b>	ECO-UV (EUV, EUV4) 220 cc cartridge
	<b>Colors</b>	Six colors (cyan, magenta, yellow, black, white, and gloss)
<b>Ink-curing unit</b>		Built-in UV-LED Lamp
<b>Print resolution (dpi)</b>		Maximum 1440 dpi
<b>Distance accuracy (when printing) (*1)</b>		Error of less than $\pm 0.3\%$ of distance traveled or $\pm 0.3$ mm ( $\pm 11.8$ mil), whichever is greater
<b>Connectivity</b>		Ethernet (10BASE-T/100BASE-TX, automatic switching)
<b>Power-saving function</b>		Automatic sleep feature
<b>Power requirements</b>		AC 100 to 240 V $\pm 10\%$ , 1.8 A, 50/60 Hz
<b>Power consumption</b>	<b>Power on</b>	156 W
	<b>Sleep mode</b>	16.7 W
<b>Acoustic noise level</b>	<b>Power on</b>	60 dB (A) or less
	<b>During standby</b>	49 dB (A) or less
<b>Outer dimensions</b>		999 (width) x 862 (depth) x 549 (height) mm (39.3 x 33.9 x 21.7 in)
<b>Weight</b>		85 kg (187.4 lb.)
<b>Environment</b>	<b>During operation (*2)</b>	Temperature: 20 to 32°C (68 to 90°F) (22°C/72°F or higher is recommended) Humidity: 35 to 80% RH (no condensation)
	<b>Not operating</b>	Temperature: 5 to 40°C (41 to 104°F), Humidity: 20 to 80% RH (no condensation)
<b>Included item</b>		Power cord, adhesive sheet, RIP & PRINT MANAGEMENT SOFTWARE (Roland VersaWorks Dual), user documentation, etc.

(\*1)

Temperature: 25°C (77°F), Humidity: 50% RH

(\*2)

Operating environment

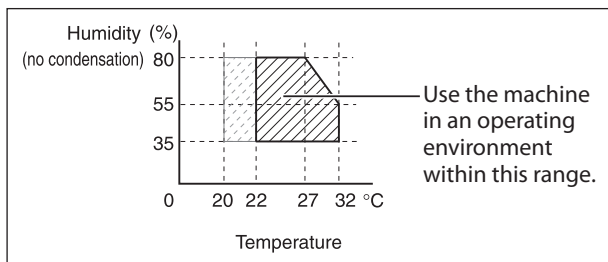

 Roland

 Roland

 Roland

 Roland

 Roland



 Roland

 Roland





1000016909

R2-161025