

CAMM-1

GR2-640

GR2-540

User's Manual

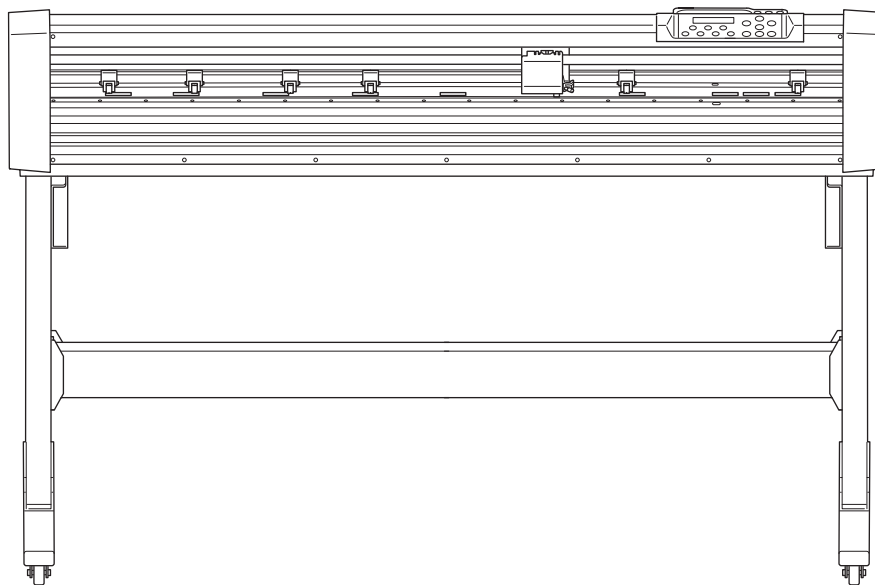

Thank you very much for purchasing this product.

- To ensure correct and safe usage with a full understanding of this product's performance, please be sure to read through this manual completely and store it in a safe location.
- Unauthorized copying or transferal, in whole or in part, of this manual is prohibited.
- The specifications of this product and the contents of this operation manual are subject to change without notice.
- The operation manual and the product have been prepared and tested as much as possible. If you find any misprints or errors, please inform us.
- Roland DG Corporation assumes no responsibility for any direct or indirect loss or damage that may occur through use of this product, regardless of any failure to perform on the part of this product.
- Roland DG Corporation assumes no responsibility for any direct or indirect loss or damage that may occur with respect to any article made using this product.

FA02570
R1-210707

<http://www.rolanddg.com/>
Copyright © 2021 Roland DG Corporation

Contents

Basic Handling Methods	5
Basic Information	6
Part Names and Functions	7
Cutting Machine Main Unit	7
Operation Panel	9
Material Used and Cuttable Area	10
Types of Materials	10
Conditions for Usable Materials	10
Cutting area	11
Menu List	12
Offline Mode Menu	12
Online Mode Menu	14
Basic Settings and Operations	15
Configuring and Viewing Environment Settings	16
Setting the Display Language and the Unit	16
Viewing System Information	17
Prioritizing the Cutting Settings of This Machine	18
Restoring Default Settings	19
Turning Off Rear Paper Sensor Detection	20
Loading the Material	21
Important Notes on Using Pinch Rollers	21
Precautions for Loading Materials	22
Loading Roll Material	23
Adjusting the Roll Material Feed	28
Loading Flat Material	29
Measuring the Material Size	31
Remove the Material	32
Pausing and Canceling Output	33
Pausing and Resuming Output	33
Canceling Output	33
Cutting Output	34
Preparations before Cutting Output	35
Recommended Cutting Conditions	36
Performing a Cutting Test	37
Adjusting the Cutting Conditions	39
Setting the Blade Force	39
Setting the Cutting Speed	40
Setting the Blade Offset	41
Creating Cutting Data	42
Creating Cutting Lines Using a Generated Data Path	42
Creating Cutting Lines with the GreatCut-R Plug-in (Adobe Illustrator/CorelDRAW)	43
Creating Cutting Lines with GreatCut-R	44
Saving Cutting Data	46
Basic Cutting	47
Setting the Output-start Location	48
Performing Cutting	49
Sending Adobe Illustrator Cutting Jobs from the Printer Driver	49
Sending CorelDRAW Cutting Jobs from the Printer Driver	52
Sending Cutting Jobs from GreatCut-R	54
Basic Printing and Cutting	57

Automatic Aligning System (AAS).....	58
Crop Mark Types	58
Setting the Margins and the Distance between Crop Marks	61
Automatic Detection of Material Feed Direction	62
Setting the AAS Detection Mode	63
Setting Crop Marks in Cutting Data	64
Setting Crop Marks with the AAS Plug-in (Adobe Illustrator)	64
Setting Crop Marks with the AAS Plug-in (CorelDRAW)	66
Setting Crop Marks with the GreatCut-R Plug-in (Adobe Illustrator/CorelDRAW)	68
Setting Crop Marks with GreatCut-R.....	69
Printing Cutting Data on Material	71
Printing Cutting Data from GreatCut-R	71
Setting the Output-start Location (Printing and Cutting)	73
Performing Cutting	74
Sending Adobe Illustrator Cutting Jobs from the Printer Driver.....	74
Sending CorelDRAW Cutting Jobs from the Printer Driver.....	77
Sending Cutting Jobs from GreatCut-R.....	79
Other Cutting	82
Section Cutting.....	83
Setting Up Section Cutting.....	83
Cutting Perforated Lines.....	84
Setting Up Perforated Cutting Using the Printer Driver	84
Setting Up Perforated Cutting with GreatCut-R	86
Setting Up Perforated Cutting from the Operation Panel	89
Cutting Multiple Sets of the Same Cutting Data	90
Duplicating Cutting Data with the AAS Plug-in	90
Duplicating Cutting Data with the GreatCut-R Plug-in	90
Duplicating Cutting Data with GreatCut-R	92
Cutting the Cutting Data Repetitively on Operation Panel.....	94
Optimizing Quality and Efficiency	97
Using GreatCut-R.....	98
Setting Up Cutting by Layer	99
Configuring the Cutting Conditions Based on the Color of Cutting Lines	99
Manually Setting the Cutting Order.....	101
Simulating the Cutting Order	102
Setting the Weed Border.....	104
Using the Material with Minimal Waste.....	106
Aligning Cutting Data by Conditions (Nesting)	106
Optimizing the Output Quality	108
Dealing with Material Thickness/Hardness (Softness).....	109
Overlap Cutting.....	109
Adjusting the Cutting-in Amount.....	112
Cutting the Corners Longer to Make It Easy to Detach Cutting Data (Over Cut)	113
Cutting Small Text and Complex Graphics Cleanly (Tangential)	114
Smoothly Cutting Arcs and Other Curves (Smoothing)	115
Preventing and Correcting Misaligned Cutting	116
Keeping Material in Place and Stabilizing Cutting Accuracy	116
Correcting Distance during Cutting Based on the Thickness of Material.....	117
Cutting Efficiently	119
Using Presets	120
Saving Cutting Conditions in Presets on the Operation Panel	120
Saving Presets Using the Printer Driver	121

Saving Presets with GreatCut-R	124
Reducing Cutting Output Time	126
Setting the Up Speed for Cutting	126
Setting the Acceleration Level for Up Speed.....	127
Setting the Crop Mark Detection Speed for the AAS Sensor	128
Other Operations and Settings	129
Settings for Preventing Problems.....	130
Preventing Positioning Errors by Setting Material Feeding	130
Using the Material with Minimal Waste.....	132
Extending the Cutting Area in Specified Directions	132
Maintenance	133
Cleaning and Replacing Consumable Parts	134
Cleaning the Machine	135
Cleaning the Parts that Come into Contact with the Material	135
Cleaning the Blade Holder Cap.....	136
Replacing Consumable Parts	137
Replacing the Blade	138
Replacing the Blade Protector.....	140
AAS Offset Test	141
Running an AAS Offset Test.....	142
Adjusting the AAS Offset	143
What to Do If.....	144
Machine Problems	145
The Machine Doesn't Run	146
Are cables connected?	146
Is the power switched on?.....	146
Is the POWER LED light on?	146
Are the communication settings correct?.....	146
Is the machine in online mode?	146
Are the software application settings correct?	146
Cutting Data Cannot Be Sent from the Operation Application.....	147
Has a communication error occurred?	147
Cutting Output Problems.....	148
Crop Marks Are Not Detected	149
Is the material loaded correctly?	149
Are you using material that is not white or is glossy?	149
Are you using a transparent material?	149
Does the material have creases or wrinkles?.....	149
Are the crop marks blurred or are they in a color other than black?	149
Are the crop marks at the correct positions?	149
Is direct sunlight or high intensity indoor light hitting the machine?	149
Is the material loaded and set up straight and securely? Are the printing results crooked?.....	150
Are the size and shape of crop marks correct?	150
Is the printing expanded or reduced?	150
Is the crop mark line width appropriate?	150
Material Feeding Is Not Smooth	151
Is the material too thick?	151
Are the grit rollers dirty?.....	151
Is the material loaded and set up straight and securely?	151
The Material Slips Away from the Pinch Rollers during Cutting.....	152

Is the material loaded in parallel with the gradations of the ruler?	152
Is the material making contact somewhere during cutting?	152
Was the material feed checked before cutting (for roll material)?	152
Are the pinch rollers used to secure both edges of the material?	152
Material Lifts Up during Cutting and Gets Damaged by Blade	153
Is wide material being used?.....	153
Is the horizontal movement speed of the cutting carriage too fast?	153
Output Quality Problems	154
Printing and Cutting Are Misaligned.....	155
Is a thick material being used?	155
Is the sensor reading inaccurate?	155
Was the machine set to feed forward some amount of material before cutting?	155
Uncut Areas Remain or Cut Edges Are Not Clean	156
Are the blade and blade holder securely mounted?	156
Is the tip of the blade broken?	156
Is there any buildup of dust or material adhesive on the tip of the blade?	156
Is there any buildup of pieces of material or dust inside the blade holder?	156
Is a thick material being used?	156
Are the blade force and cutting speed appropriate for the material being cut?	156
Is the amount of blade offset correct?	156
Is the smoothing function set to [Disabled] ?.....	157
Is the blade protector damaged or deformed?.....	157
The Machine Cuts the Carrier Paper	158
Are the blade tip adjustment and blade force appropriate for the material being cut?.....	158
The Machine Cuts the Same Area Twice.....	159
Are there overlapping lines?	159
Is the step count set to 1 in GreatCut-R?	159
Misaligned Cutting Start and End Points.....	160
Was material feeding set?	160
Messages on the Operation Panel	161
Messages	162
"File Too Large Press OFFLINE"	162
"Buffer Empty Press OFFLINE"	162
"Reboot Please"	162
"File size exceed 16M Please adjust"	162
"Please Stop Transmit File: Press OFFLINE"	162
"AAS Detect Fail".....	162
Error Messages.....	163
"Error; Rollers Are /Up Sensor"	163
"Error; Check Media Or Drum Or X Motor"	163
"Error; Check Media Or Y Motor"	163
"Error; Check Carriag Sensor Or VC Motor"	163
"Out Of Space; # of Copies finished".....	163
"HPGL/2 Cmd. Error"	163
"Communication Error Setup Press MISC"	163
"AAS File Command Error"	164
Appendix.....	165
Operations When Moving the Unit	166
Removing the Material and Blade Holder	167
Securing the Cutting Carriage and Pinch Rollers with Retainers	168
Removing the USB Cable Tie	169
Memo.....	170

Basic Handling Methods

Basic Information

Part Names and Functions.....	7
Cutting Machine Main Unit.....	7
Operation Panel	9
Material Used and Cuttable Area	10
Types of Materials	10
Conditions for Usable Materials.....	10
Cutting area.....	11
Menu List.....	12
Offline Mode Menu	12
Online Mode Menu.....	14

Part Names and Functions

Cutting Machine Main Unit

Front

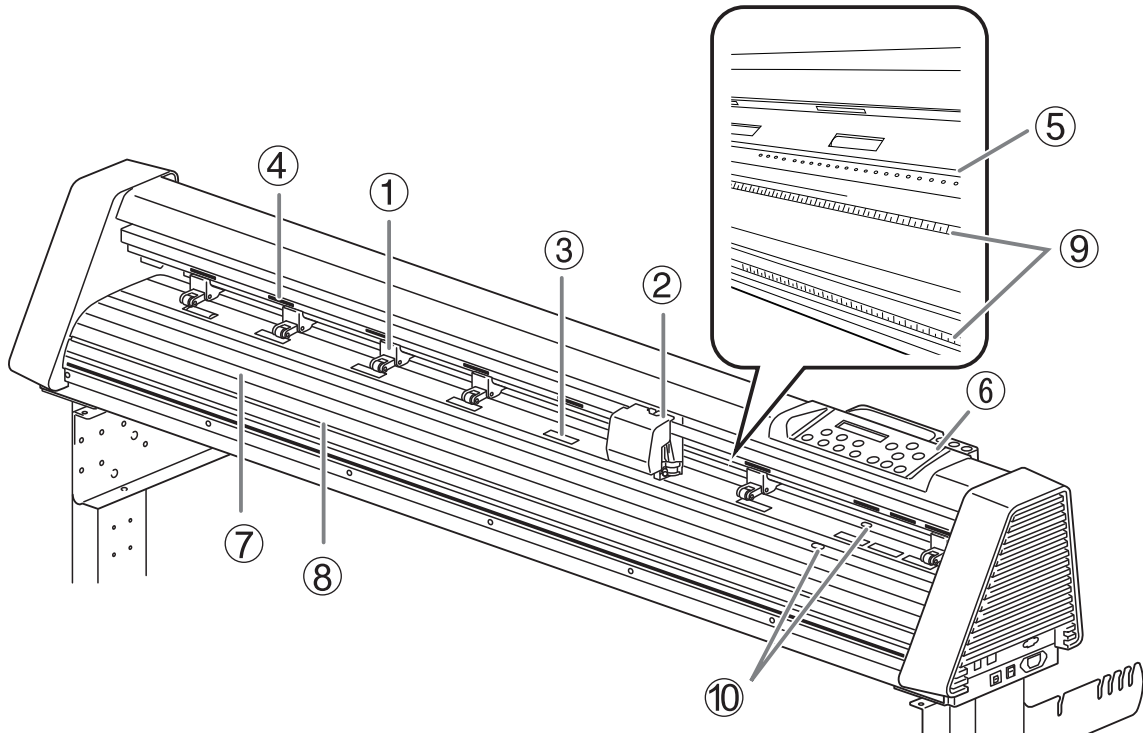

No.	Name	Function overview
①	Pinch rollers	When you lower the lever, this part pinches the material. Lift the lever to release the material.
②	Cutting carriage	Install the blade holder. This part moves to the left and right to cut the material.
③	Grit rollers	These rollers feed the material to the front and rear.
④	Grit patterns	These indicate the locations of the grit rollers. When loading the material, be sure to place the pinch rollers within the area indicated by each of these patterns.
⑤	Blade protector	This is the path that the blade takes during cutting. It protects the tip of the blade.
⑥	Operation panel	The panel containing the buttons used to operate the machine.
⑦	Platen	This is the path over which the material passes.
⑧	Cutting groove	The safe blade slides along the groove and separates the material.
⑨	Rulers	Load the material using the rulers as a guide.
⑩	Paper sensors	These sensors detect the presence/absence of material.

Rear

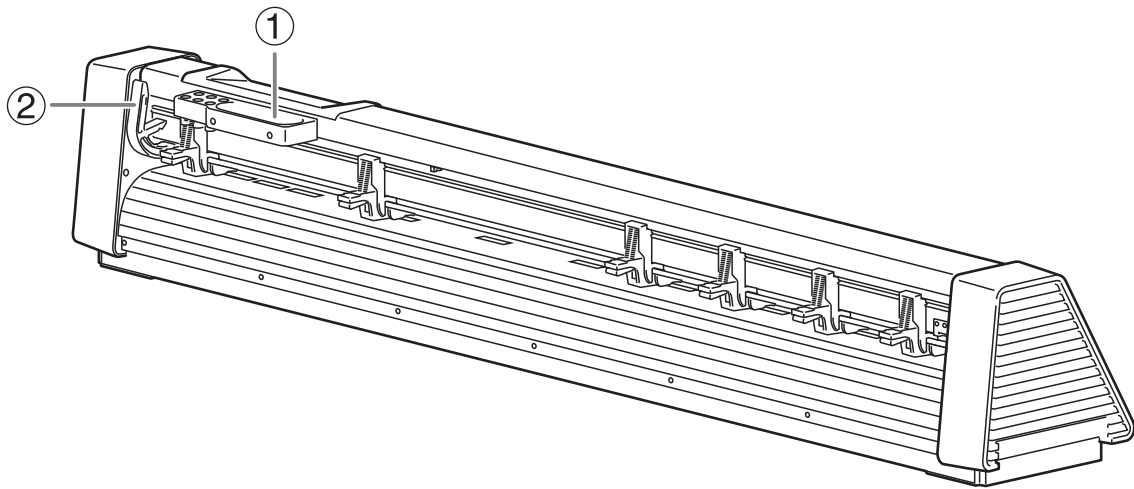

No.	Name	Function overview
①	Small article storage	This space is for placing small tools such as clips and blades.
②	Lever	Use this to raise and lower the pinch rollers. You operate this to move the pinch rollers or to load materials.

Side

GR2-640

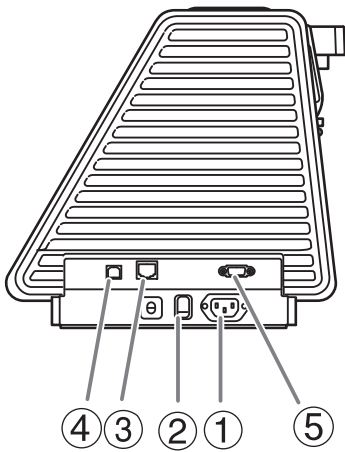



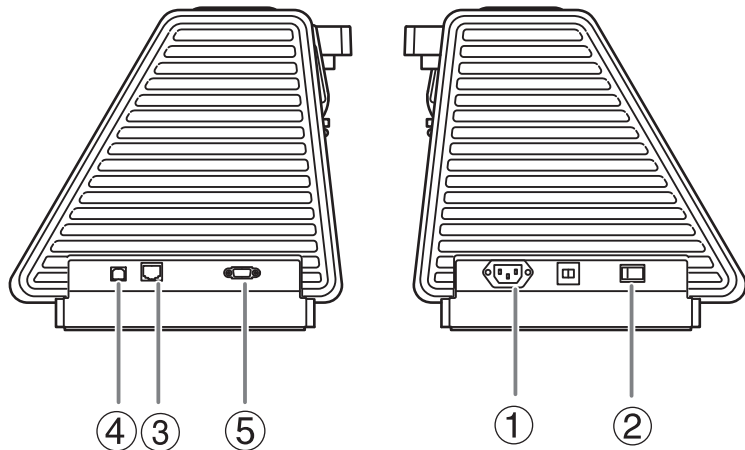





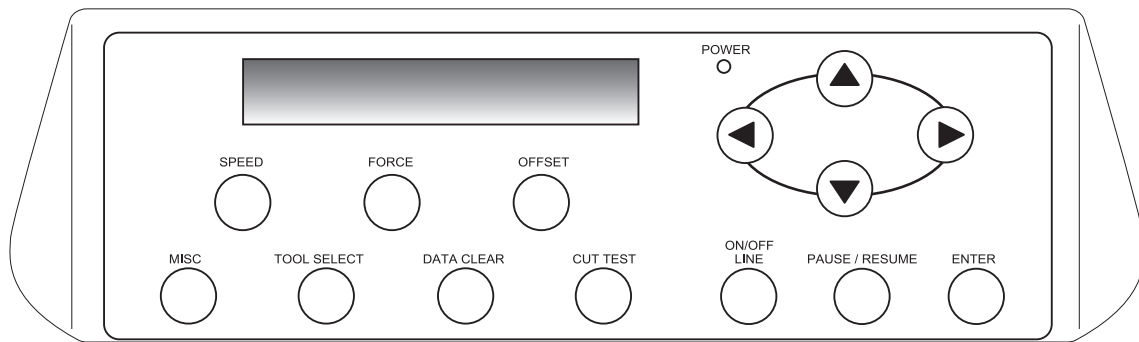

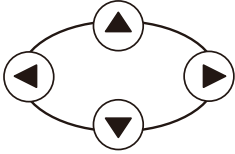

GR2-540



No.	Name	Function overview
①	Power-cord connector	This is for connecting a power cord.
②	Power switch	Switch the power on/off.
③	Ethernet connector	Use this to connect an Ethernet cable.
④	USB connector	This is for connecting a USB cable.
⑤	Serial connector (RS-232C)	Use this to connect the RS-232C cable. This is disabled when a USB cable is connected.

Operation Panel



Part	Name	Details	Notation in this manual
	Display screen	This displays various setting menus and other information.	
	POWER LED light	Lights up when the machine is turned on.	[POWER]
	Cursor keys	Use these keys to select settings for menu items, to move the material or cutting carriage, and for other such operations.	[◀][▼][▲][▶]
	ENTER key	Use this key for such tasks as enabling setting values.	[ENTER]
	PAUSE/RESUME key	This key pauses the printing operation. Press this key again to resume operation.	[PAUSE/RESUME]
	ON/OFF LINE key	If material is set up, press this key to switch the mode.	[ON/OFF LINE]
	SPEED key	Set the cutting speed and quality values.	[SPEED]
	FORCE key	Set the force (pressure) of the blade.	[FORCE]
	OFFSET key	Set the blade offset.	[OFFSET]
	MISC key	Set basic operations or view system information.	[MISC]
	TOOL SELECT key	Use this key when you want to set the cutter control or restore default settings.	[TOOL SELECT]
	DATA CLEAR key	Use this key to delete the cache.	[DATA CLEAR]
	CUT TEST key	Set up a cutting test or set the conditions for a cutting test.	[CUT TEST]

Material Used and Cuttable Area

Types of Materials

The two main types of materials used with this machine are shown below.

- Roll material
Media wound onto a paper tube
- Flat material
Media not wound onto a paper tube such as standard-size material

Various materials are selectable according to your purpose. For detailed information about each material, contact your material supplier.

MEMO

This manual may collectively refer to roll materials and flat materials as "media."

Conditions for Usable Materials

The conditions for materials that can be loaded in the machine are shown below.

		GR2-640 (64 in.)	GR2-540 (54 in.)
Size	Width	50 to 1,782 mm (1.97 to 70.1 in.)	50 to 1,594 mm (1.97 to 62.7 in.)
	Length* ¹	120 mm (4.73 in.) or more (flat material)	
	Cuttable material thickness* ²	0.8 mm (31.4 mil.) or less (Depending on material type)	
	Max. outer diameter of roll material	160 mm (6.3 in.)* ³ (210 mm [8.2 in.] when roll holder flanges are not used)	
	Inner diameter of roll material core* ³	76.2 mm (3 in.)	
Weight	Max. weight of roll material	24 kg (52.9 lb.)	20 kg (44.1 lb.)

*1 There is no limit for roll materials

*2 Includes the thickness of carrier paper

*3 When roll holder flanges are used

Other Conditions

Materials with any of the following characteristics cannot be used:

- Strongly warped or bent
- Edges are not parallel
- Transparent
- Colored (when printing and cutting)

MEMO

For printing and cutting, use white material with carrier paper that can be printed on using a laser or inkjet printer.

Cutting area

The cutting area along the material's horizontal plane (the direction in which the cutting carriage moves) is determined by the position of the pinch rollers set up on both edges of the material. When printing and cutting use crop marks, the maximum area in the vertical and horizontal directions is reduced by an amount equal to the crop mark size and margin.

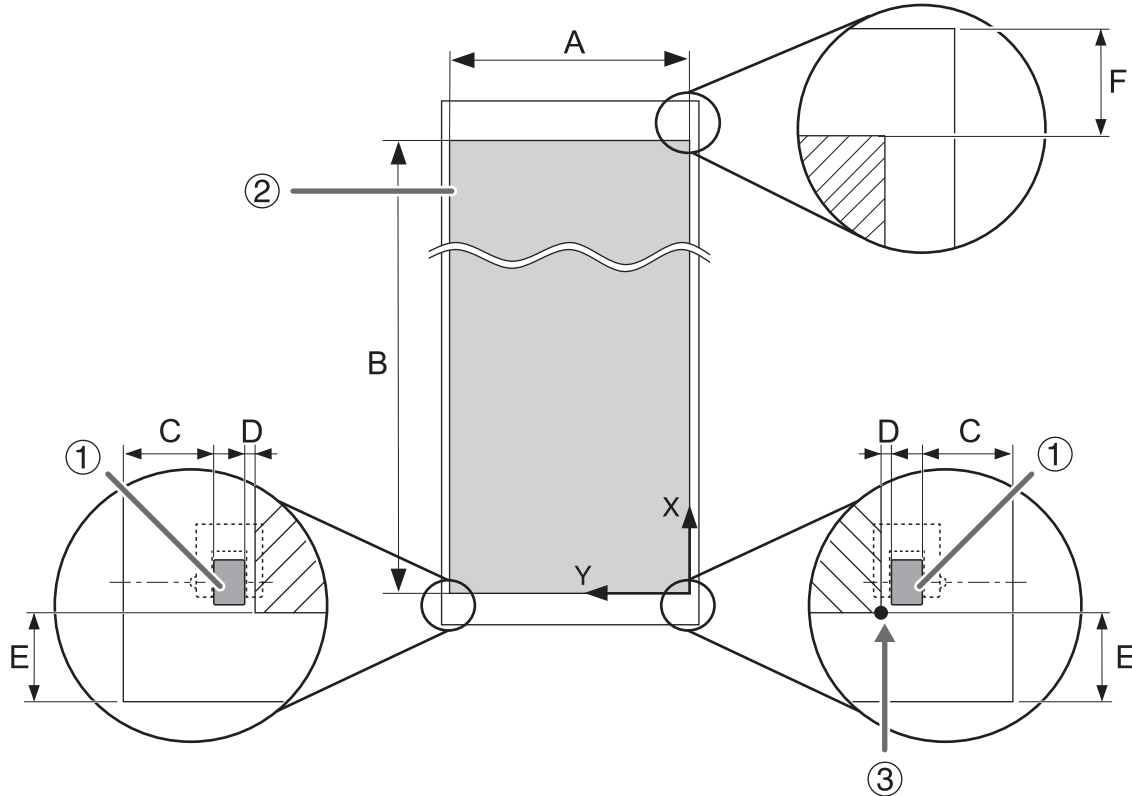

①	Pinch roller
②	Cutting area
③	Cutting coordinates origin
A	64-inch model: Max. 1,627 mm (64 in.), 54-inch model: Max. 1,372 mm (54 in.)
B	Max. 50,000 mm (1,968 in.)* ¹
C	Material length (B) is no more than 4,000 mm (157.48 in.): 0.5 to 25 mm (0.02 to 0.98 in.) Material length (B) is more than 4,000 mm (157.48 in.): 25 mm (0.99 in.) or more
D	Approx. 1 mm (0.04 in.)
E	Min. 20 mm (0.79 in.)
F	Min. 80 mm (3.15 in.)/50 mm (1.97 in.)* ²

*1 Refer to "Specifications" in the Setup Guide for information on the range of assured accuracy.

*2 When extended in the feed direction (length)

Menu List

Offline Mode Menu

Offline mode is a preparation state in which a connection to the computer is not possible. It is a mode for configuring all machine settings regardless of whether there is material that has been set up.

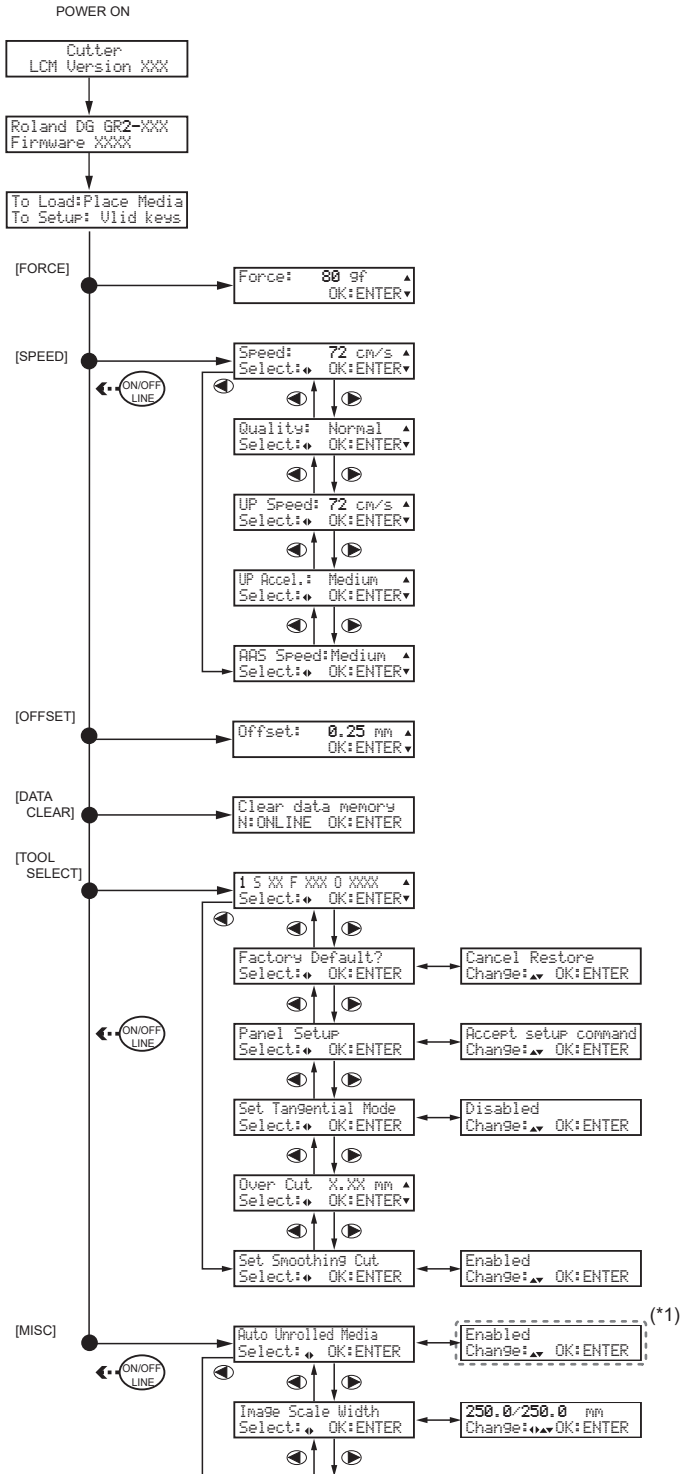

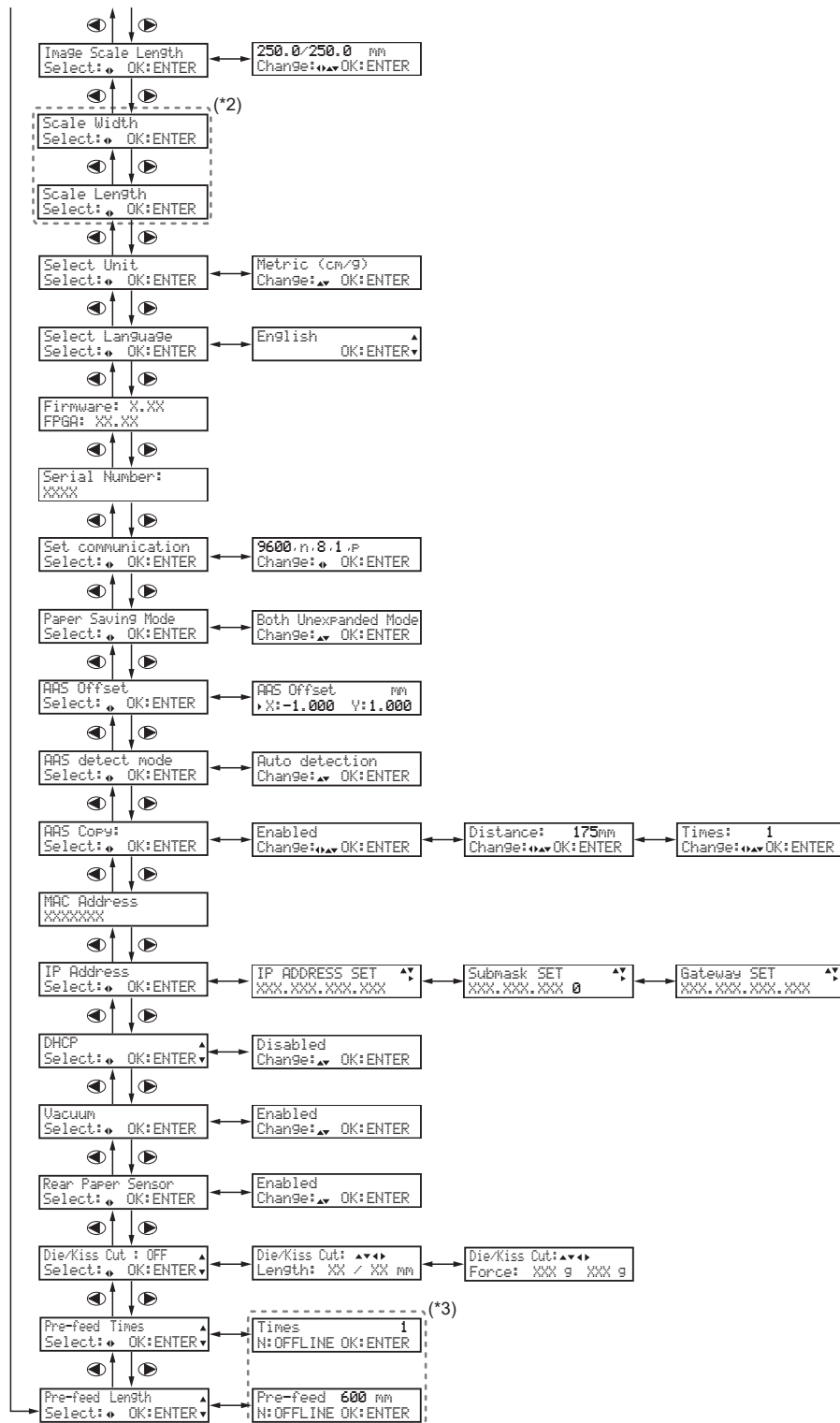

(*1) When this is set to "Enabled", the "Pre-feed Length" menu is displayed automatically.

(*2) This is normally not used.

(*3) This can be set when the "Auto Unrolled Media" menu is set to "Enabled".

Online Mode Menu

Online mode is the cutting start mode displayed when material is loaded in the machine. When outputting cutting data, set the machine to online mode to receive cutting jobs from the computer. You can press [ON/OFF LINE] to switch between online and offline modes.

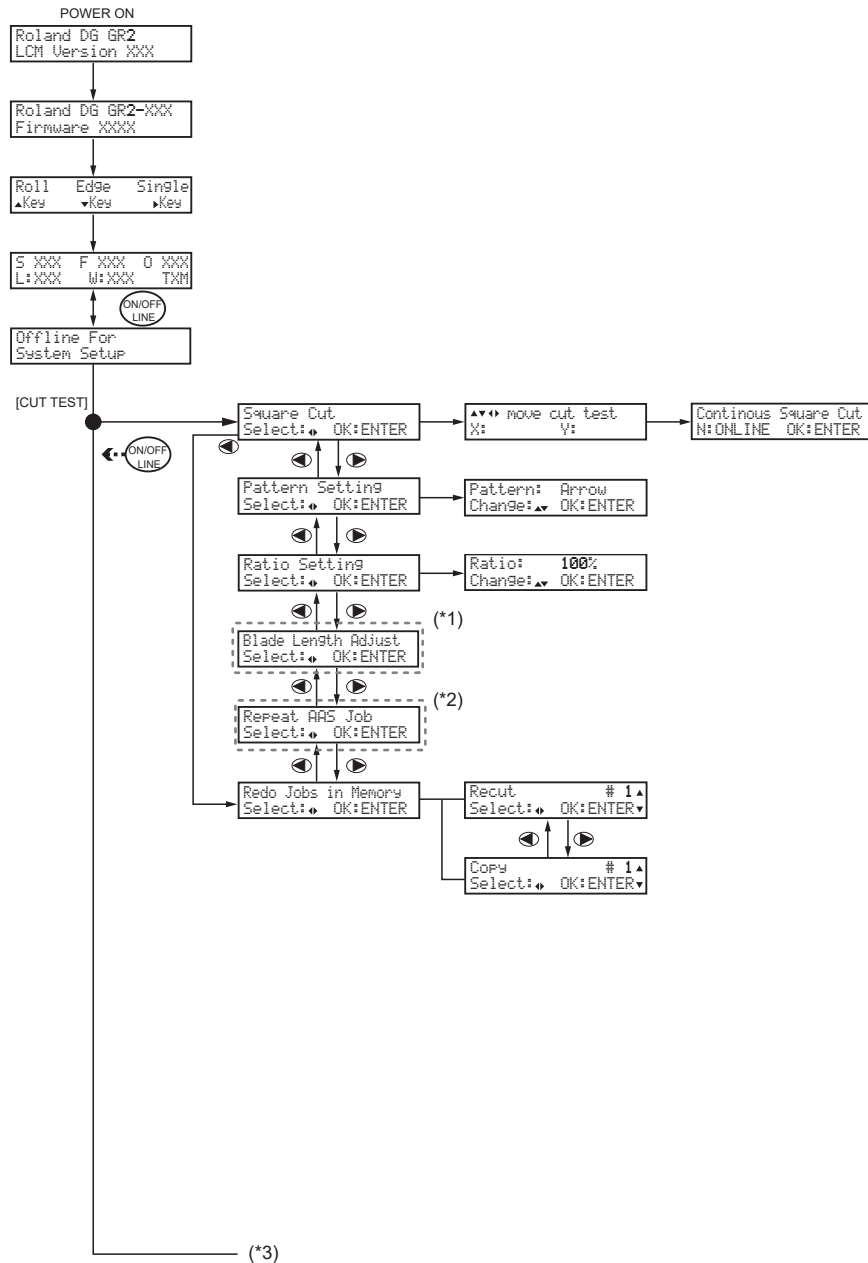

(*1) This machine does not use this function.

(*2) Displayed after cutting data with crop marks is output. When this menu is displayed, the "Recut/Copy" menu is not. (One of these menus is displayed depending on the last data output.)

(*3) To use the offline mode menu, press [ON/OFF LINE].

Basic Settings and Operations



Configuring and Viewing Environment Settings	16
Setting the Display Language and the Unit.....	16
Viewing System Information	17
Prioritizing the Cutting Settings of This Machine.....	18
Restoring Default Settings	19
Turning Off Rear Paper Sensor Detection.....	20
Loading the Material	21
Important Notes on Using Pinch Rollers.....	21
Precautions for Loading Materials	22
Loading Roll Material	23
Adjusting the Roll Material Feed.....	28
Loading Flat Material	29
Measuring the Material Size	31
Remove the Material.....	32
Pausing and Canceling Output.....	33
Pausing and Resuming Output	33
Canceling Output.....	33

Configuring and Viewing Environment Settings

Setting the Display Language and the Unit

This feature sets the language and units of measurement displayed on the display screen of the operation panel.

Procedure

1. Press [MISC].
If material is loaded, press [ON/OFF LINE] to switch to offline mode.
2. Set the display language.
 - (1) Press [▶] several times to display the screen shown below.
The screen displays "Select Language" and "Select: ◀ OK: ENTER".
 - (2) Press [ENTER].
 - (3) Press [▲] or [▼] to select the display (menu) language.
 - (4) Press [ENTER] to confirm your entry.
3. Select the measurement unit for length.
 - (1) On the following screen, press [ENTER].
The screen is displayed with the selected language.
The screen displays "Select Unit" and "Select: ◀ OK: ENTER".
 - (2) Press [▲] or [▼] to select the measurement unit for length.
 - (3) Press [ENTER] to confirm your entry.
4. Press [ON/OFF LINE] to go back to the original screen.

MEMO

Default setting:

- Display language: "English"
- Unit: "Metric"

Viewing System Information

Check the system information, including the firmware version, IP address, and MAC address.

Procedure

1. Press [MISC].
If material is loaded, press [ON/OFF LINE] to switch to offline mode.
2. Press [▶] several times to display the screen shown below.

Display screen	Information
DHCP Select: ◀ OK:ENTER ▶	IP address assigned by the DHCP server on the network
IP Address Select: ◀ OK:ENTER	Manually set a static IP address for the cutting machine
MAC Address XXXXXXXX	MAC address of device
Set communication Select: ◀ OK:ENTER	Set the communication speed of the RS-232C cable
Firmware: X.XX FPGA: XX.XX	Firmware version
Serial Number: XXXX	Device serial number

MEMO

For information on how to set up a network, see the Installation Guide.

3. Press [ON/OFF LINE] to go back to the original screen.

Prioritizing the Cutting Settings of This Machine

The cutting settings on the operation panel can be prioritized over the printer driver settings. For cutting settings (blade force, speed, quality, and offset), the printer driver (or GreatCut-R/VersaWorks) settings are usually prioritized.

Procedure

1. Press [TOOL SELECT].
If material is loaded, press [ON/OFF LINE] to switch to offline mode.
2. Press [▶] several times to display the screen shown below.

```
Panel Setup  
Select:◀▶ OK:ENTER
```

3. Press [ENTER].
4. Press [▲] or [▼] to select "Control panel only".

This setting prioritizes the cutting conditions set up on the operation panel over the printer driver settings. If this is set to "Accept setup command", the printer driver (or GreatCut-R/VersaWorks) settings are prioritized.

```
Control panel only  
Change:▲▼ OK:ENTER
```

5. Press [ENTER] to confirm your entry.
6. Press [ON/OFF LINE] to go back to the original screen.

MEMO

Default setting: "Accept setup command"

Restoring Default Settings

This procedure returns all edited settings to their factory default values.

MEMO

This operation restores all settings to their default settings, which deletes all changes made to the settings by the user. Keep a record of any necessary information such as cutting conditions.

Procedure

1. Press [TOOL SELECT].
If material is loaded, press [ON/OFF LINE] to switch to offline mode.

2. Press [▶] to display the screen shown below.

```
Factory Default?
Select:◀ OK:ENTER
```

3. Press [ENTER].

The screen shown below appears. If you are not restoring default settings, proceed directly to step 5.

```
Cancel Restore
Change:▲▼ OK:ENTER
```

4. Press [▼] to display the screen shown below.

```
Sure to Restore
Change:▲▼ OK:ENTER
```

5. Press [ENTER].

Press [ENTER] on the "Cancel Restore" screen to return to the original screen.

6. When the following screen is displayed, turn off the power.

```
Reboot Please
```

Turning Off Rear Paper Sensor Detection

You can turn off the detection of the paper sensor at the rear side of the cutting machine. As this feature informs the machine that the material is properly loaded, we recommend that you set this to "Enabled" for normal use. This option is effective for measuring the material size in roll mode or edge mode.

Procedure

1. Press [MISC].
If material is loaded, press [ON/OFF LINE] to switch to offline mode.
2. Press [▶] several times to display the screen shown below.
The screenshot shows a menu with the text "Rear Paper Sensor" on the first line and "Select: ◀ OK:ENTER" on the second line. The text is displayed in a monospaced font within a rectangular border.

```
Rear Paper Sensor
Select: ◀ OK:ENTER
```
3. Press [ENTER].
The current setting is displayed.
4. Press [▲] or [▼] to set this to "Disabled".
5. Press [ON/OFF LINE] to go back to the original screen.

MEMO

Default setting: "Enabled"

Loading the Material

Important Notes on Using Pinch Rollers

When using the pinch rollers for setting up the material, be sure to follow the precautions below. Keep the lever raised when the pinch rollers are not in use.

- Be sure to raise the pinch rollers before moving them. Use the lever to raise or lower the pinch rollers.
- To move a pinch roller, push the pinch roller support (①).

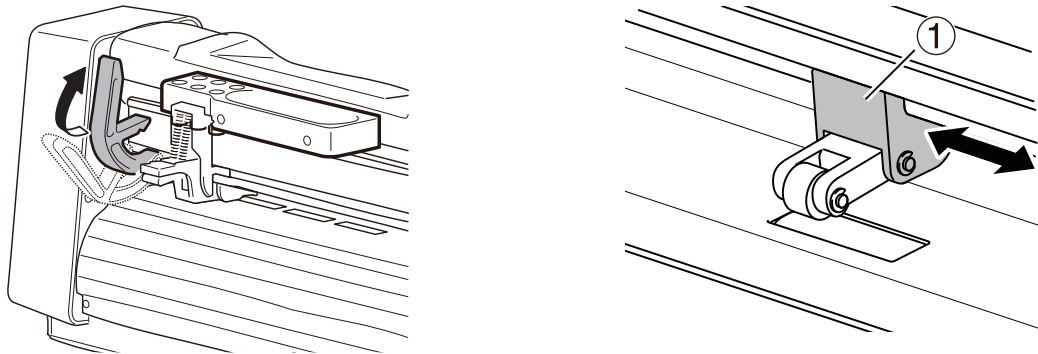

MEMO

Push the grip on the top side of a pinch roller to individually raise pinch rollers that are not in use. To return a pinch roller to its original position, push up the grip on the bottom side while supporting the grip on the top side.

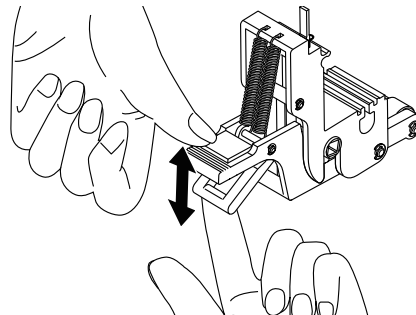

IMPORTANT

Gripping both the top and bottom grips of a pinch roller at the same time may break the grips.

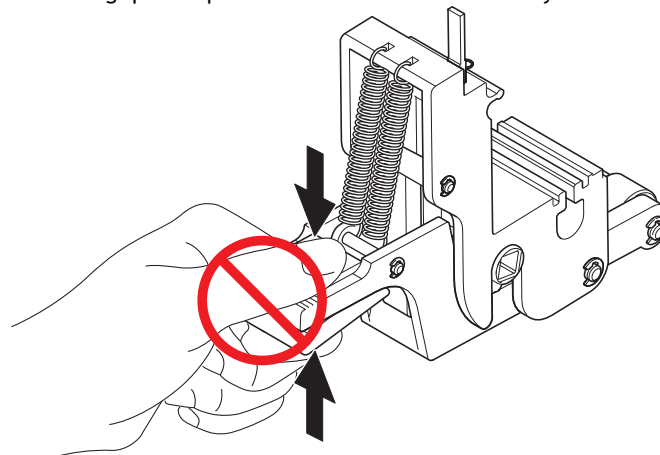

Precautions for Loading Materials

Make sure that the material is loaded and set up correctly in the machine.

- Place the pinch rollers with the necessary space at both edges of the material.
- Be sure to place the pinch rollers on both edges of the material within the grit patterns that indicate the position of grit rollers. If the pinch rollers are not placed within the range of the grit patterns, the material cannot be fed properly.
- If the material lifts up even when it is fixed by pinch rollers on both edges, or when loading large material, place pinch rollers in the middle of the material. When placing pinch rollers in the middle of the material, avoid placing them where there is cutting data as the pinch rollers may leave marks on the material.
- Make sure that the material is loaded straight. If not, the material cannot be fed properly.

For printing and cutting using the automatic aligning system (AAS), follow the rules below to ensure correct crop mark reading:

- Avoid using any lighting that may shine horizontally onto the AAS sensor inside the cutting carriage.
- Place the origin of crop marks (①) at the front right when facing the machine.
- Ensure that the two crop marks (the origin ① and second mark) at the front are not angled when loading the material.

Allowable range of slant (②): No more than half the length of a crop mark (③)

- Ensure that the first crop mark in the Y direction is not over the grit rollers and place it near the cutting carriage path.

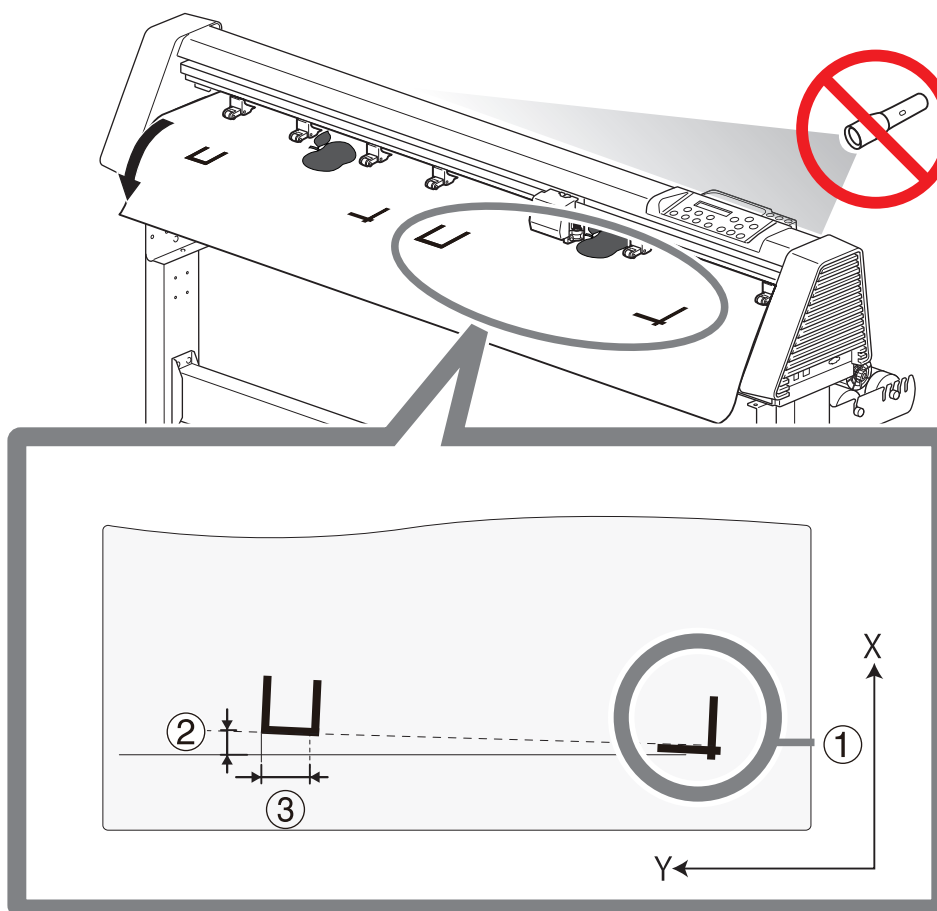

Loading Roll Material

Load the roll material on the cutting machine.

- ⚠ CAUTION** **Load the roll media correctly.**
 Otherwise the media may fall and cause injury.
- ⚠ CAUTION** **The roll media is approximately 24 kg (52.9 lb.) (54-inch model: 20 kg [44.1 lb.]).**
 To avoid injury, handle the roll media with care.
- ⚠ CAUTION** **Never load media that weighs over 24 kg (52.9 lb.) (54-inch model: 20 kg [44.1 lb.]).**
 The machine may fail to withstand the weight and tip over or cause the media to fall.

Procedure

- 1.** Determine the left and right edge positions of the roll material with the grit patterns as a reference.
 Ensure that the right edge of the material (looking from the front of the machine) is positioned so that it is within the range of the grit patterns and covers the paper sensor (①).

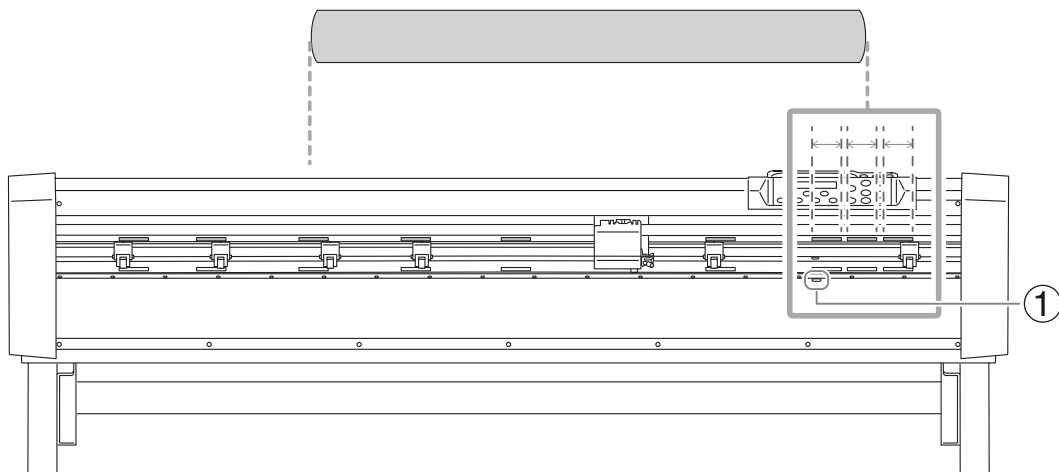

- 2.** Insert the roll holder flanges into the paper tube of the roll material.
 Turn the knobs of the roll holder flanges to securely attach them to the roll material.

MEMO

Roll holder flanges cannot be used for roll materials with an outer diameter of 160 mm (6.30 in.) or more or for roll materials with 2-inch paper tubes.

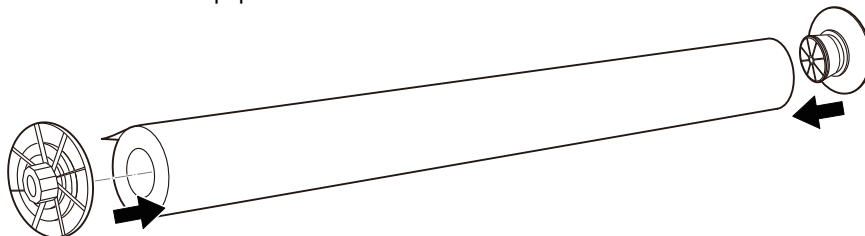

- 3.** Place the roll holder guide bushes by aligning them at both ends of the roll material.
 Move the roll holder guide bushes with the resin bolts loosened.

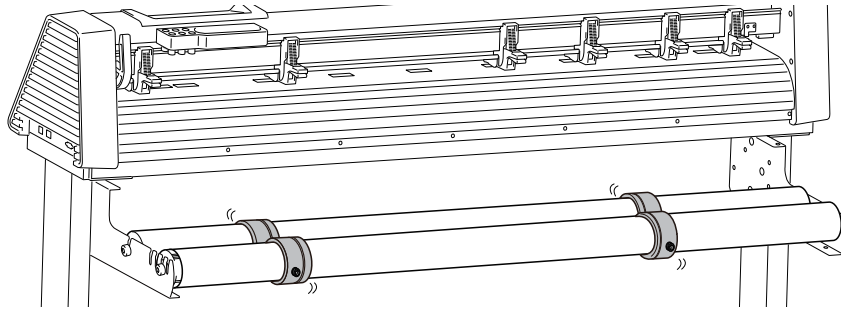

4. Place the roll material in the roll holder.

- When using the roll holder flanges, place them in the center of the grooves on the roll holder guide bushes to prevent these flanges from interfering with the sides of these grooves. This interference may lead to misaligned material due to lopsided material feeding.
- If roll holder flanges are not used, place the roll material between the two roll holders and the front, back, left, and right roll holder guide bushes. When placing the damper-equipped roll holder in notches up to the second set of notches on the machine side of the roll holder supports, remove the roll holder guide bushes from this roll holder.

When roll holder flanges are used

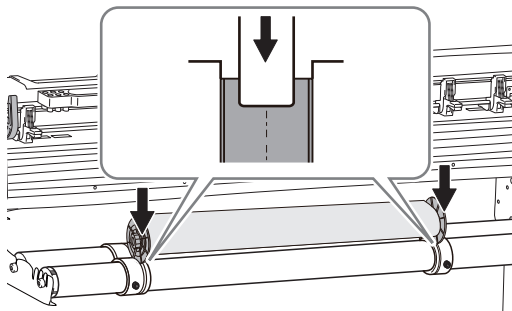

When roll holder flanges are not used

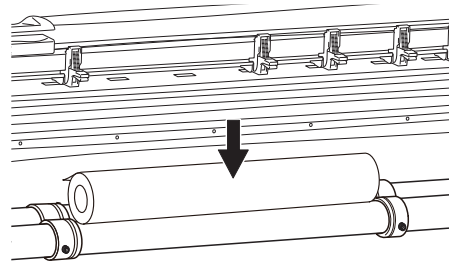

5. Tighten the resin bolts of the roll holder guide bushes.

IMPORTANT

To evenly distribute the weight of the roll holder's rotation shaft during roll material feeding, place the resin bolts of the roll holder guide bushes on the machine side and the front side facing 180 degrees opposite of each other as shown in the pictures.

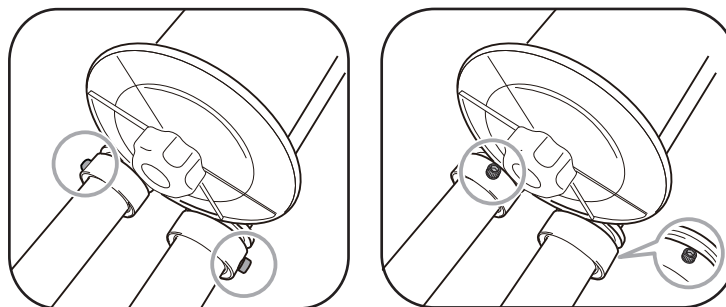

6. Check that the lever is raised.

If the lever is lowered, raise the lever.

7. Pass the front end of the roll material between the pinch rollers and the grit rollers from the rear side of the machine (①) and pull it straight out to above the platen (②) using the scale of the rulers (in two locations: one on the top and one on the bottom) as a guide.

Feed the material so it is slightly longer than necessary, leaving some slack.

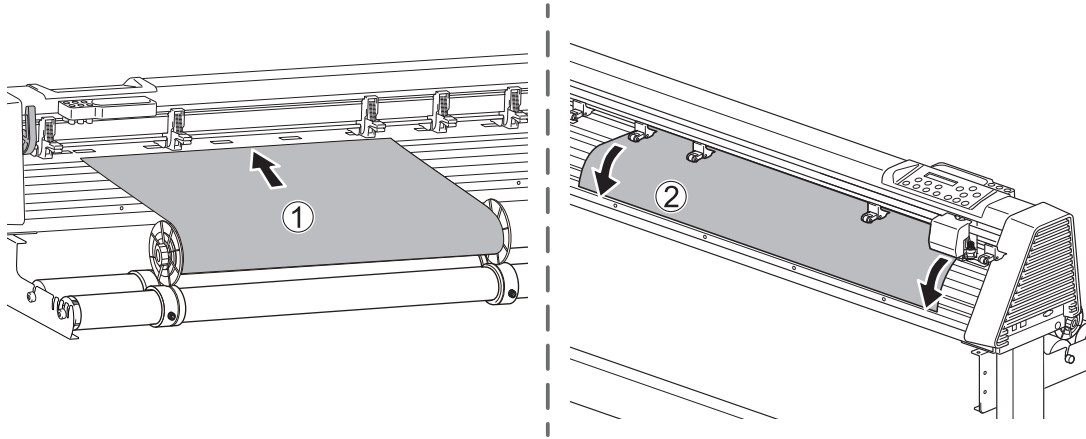

8. Move the pinch rollers and place them on both edges of the roll material.

Check that the pinch rollers are positioned within the range of the grit patterns. If the pinch rollers are not placed within the range of the grit patterns, the material cannot be fed properly.

Position the pinch rollers on the edges so that each one is 0.5 to 25 mm (0.02 to 0.98 in.) (if the roll material used is more than 4 m [157.49 in.] long, then more than 25 mm [0.99 in.]) inside of the respective left or right edge of the material.

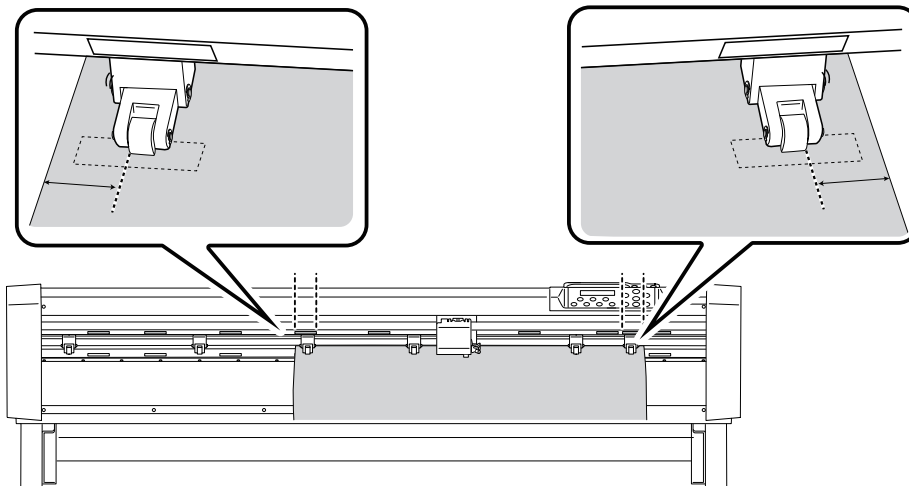

9. When loading material that lifts up easily, place the pinch rollers on the middle of the material. Individually raise pinch rollers that are not in use.

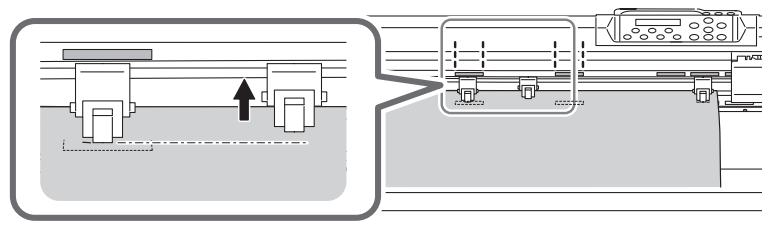

10. Lower the lever.

The material is secured in place.

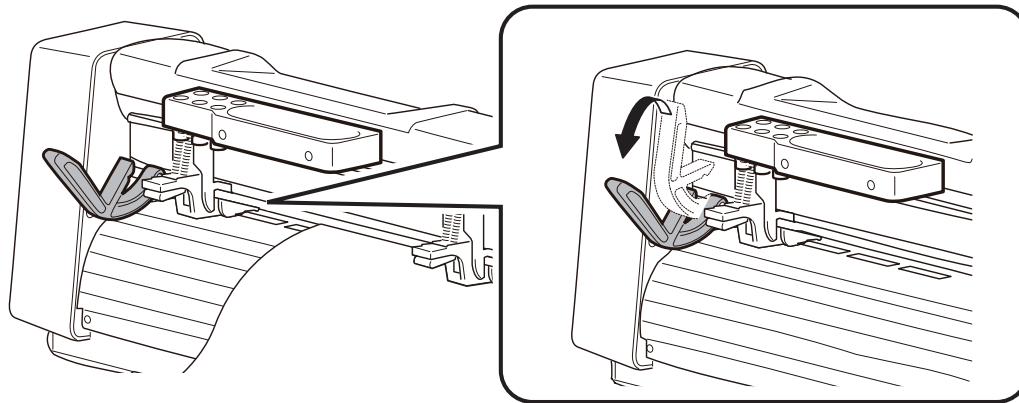

11. Check that the roll material is equally taut on the left and right.

Twisted material may indicate that it is not being fed in a straight manner. Adjust the position of the material and reload it.

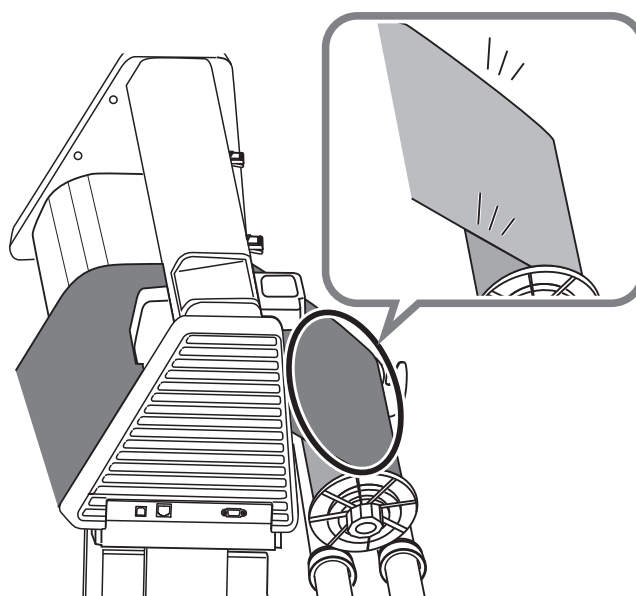

12. Set the material feeding so the material length required for the cutting data is fed before cutting starts.

☛ P. 130 "Preventing Positioning Errors by Setting Material Feeding"

13. For roll material 4 m (157.49 in.) or more in length, feed the loaded material, checking that there is no misalignment or twisting.

- (1) Turn on the power.

When you turn on the power, the screen for measuring the material size appears.



- (2) Press [▲] or [▼] to measure the material size.
 (3) Press [▼] to feed about 1 to 2 meters (39.37 to 78.74 in.) of the material.

MEMO

After the material size is measured, press a cursor key to display the screen for setting the output-start location. To test the feeding of the material and check that it has been set up, only press [▼] on this screen.

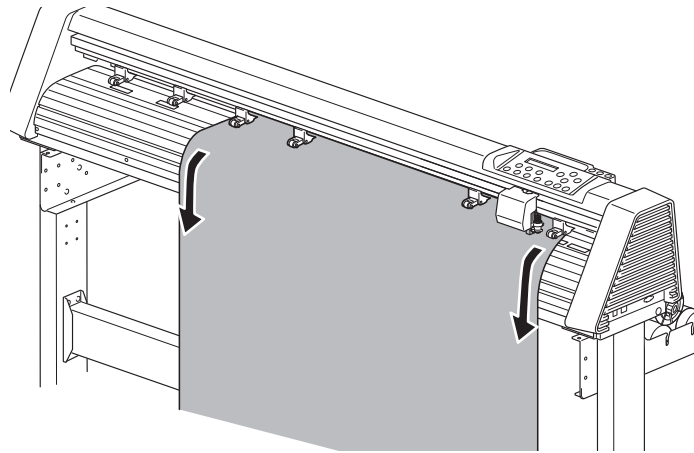

- (4) Check the status of the cutting surface (part near the cutting carriage path), the material edges, and the material on the rear side of the machine.

Incorrectly loaded material will lead to misalignment, so reload the material if:

- The surface of the material displays waviness or wrinkles.
- The roll material is fed diagonally.
- The material on the rear side of the machine is twisted.

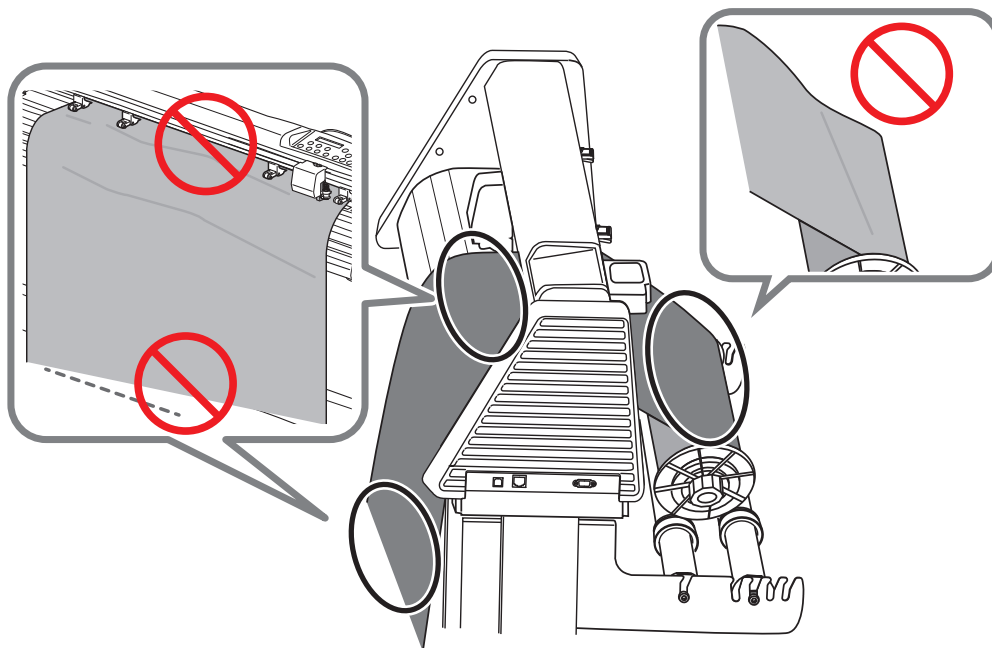

- (5) Press [ON/OFF LINE] twice to return the material to its original position.

IMPORTANT

Remove the roll material when it is not in use.

Do not leave roll material loaded on the machine for long periods of time. Be sure to remove and store the media when not in use. Leaving roll material loaded on the machine for a long period of time will cause the material to sag, which can adversely affect output quality.

RELATED LINKS

- P. 10 "Conditions for Usable Materials"
- P. 11 "Cutting area"
- P. 22 "Precautions for Loading Materials"
- P. 31 "Measuring the Material Size"

Adjusting the Roll Material Feed

Adjust the roll holder so it tracks the rotation of the roll material, ensuring the smooth feeding of this material.

Procedure

1. Turn the damper (①) to adjust how much the roll holder rotates.

Make adjustments using the adjustment reference sticker (②) and the damper number (③) as references. The roll holder's rotation decelerates as the number of damper (③) increases.

- If the roll material jumps from the roll holder, turn the damper toward the main unit.
- If the roll material is slack even after adjusting the tension of the roll material, turn the damper toward the front.

When turning the damper, loosen the screw on the side using a hex wrench.

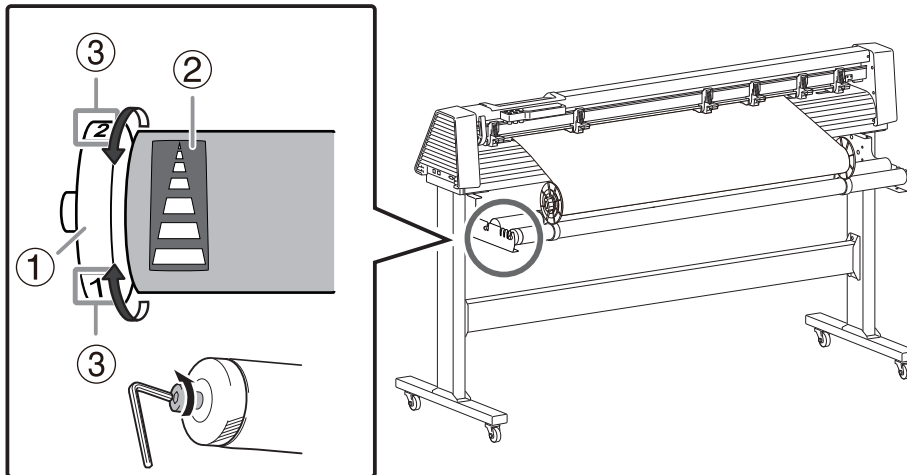

Loading Flat Material

Load the flat material on the cutting machine. If flat material is used, it must be at least 100 mm (3.94 in.) longer (70 mm [2.76 in.] when the cutting area is extended in the length direction) than the vertical size of the cutting data. This is the length required for the pinch rollers to feed out the material to the front and rear.

- ⚠ CAUTION** Never load media that weighs over 24 kg (52.9 lb.) (54-inch model: 20 kg [44.1 lb.]).
The machine may fail to withstand the weight and tip over or cause the media to fall.

Procedure

1. Check that the lever is raised.
If the lever is lowered, raise the lever.
2. Pass the material in a straight manner between the pinch rollers and grit rollers using the gradations of the rulers (in two locations: one on the top and one on the bottom) as a guideline.
Ensure that the right edge of the material (looking from the front of the machine) is positioned so that it is within the range of the grit patterns and covers the paper sensor (①).

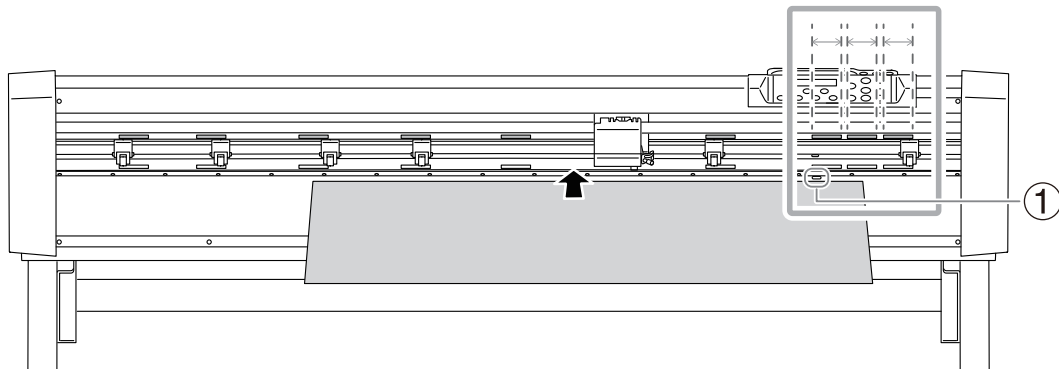

3. Move the pinch rollers and place them on both edges of the flat material.
Check that the pinch rollers are positioned within the range of the grit patterns. If the pinch rollers are not placed within the range of the grit patterns, the material cannot be fed properly.
Position the pinch rollers on the edges so that each one is 0.5 to 25 mm (0.02 to 0.98 in.) (if the roll material used is more than 4 m [157.49 in.] long, then more than 25 mm [0.99 in.]) inside of the respective left or right edge of the material.

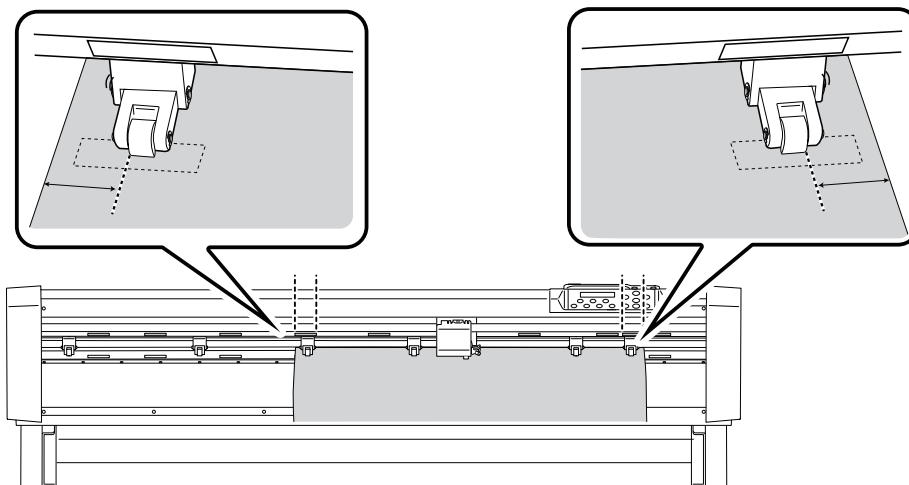

MEMO

Sprocket-fed perforated material has perforations along each edge. If the pinch rollers are positioned over the perforations, the material cannot be fed correctly. When using this material with the machine, place the pinch rollers to avoid the perforations.

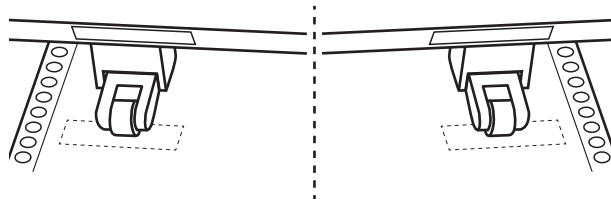

4. When loading material that lifts up easily, place the pinch rollers on the middle of the material. Individually raise pinch rollers that are not in use.

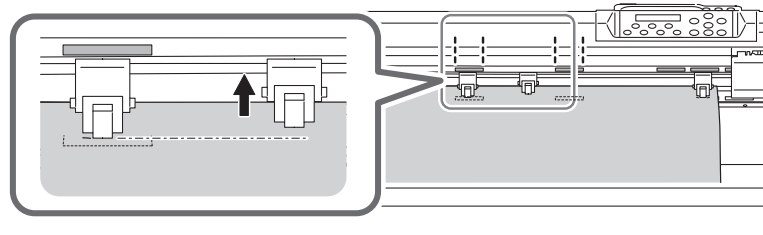

5. Lower the lever.
The material is secured in place.

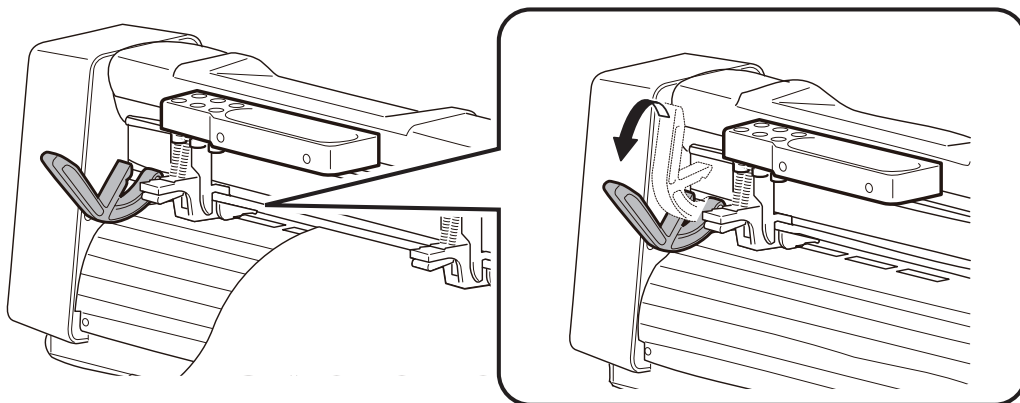

MEMO

When you turn on the power, the screen for measuring the material size appears.



6. When loading material longer than 1.6 m (63.00 in.), set the material feeding so the material length required for the cutting data is fed before cutting starts.

➤ P. 130 "Preventing Positioning Errors by Setting Material Feeding"

RELATED LINKS

- P. 10 "Conditions for Usable Materials"
- P. 11 "Cutting area"
- P. 22 "Precautions for Loading Materials"
- P. 21 "Important Notes on Using Pinch Rollers"
- P. 31 "Measuring the Material Size"

Measuring the Material Size

The size of the material loaded in the cutting machine can be measured and recorded in the machine. Raising the lever resets the memory of material size, and therefore the size of the material must be measured every time the lever is raised and lowered.

⚠ WARNING Never touch the cutting carriage while measurement is in progress.
The cutting carriage moves at high speed. Coming into contact with the moving carriage may cause injury.

Procedure

1. Turn on the power.
Load the material in the machine, if it has not yet been loaded.
2. When the following screen appears, press [▲], [▼] or [▶] to select a measurement mode.
The cutting carriage moves at high speed to start measurement. When the measurement is finished, the cutting carriage stops and the measurements are displayed on the screen.

```

Roll   Edge   Single
▲Key   ▼Key   ▶Key
  
```

Display Settings	Key	Measurement mode	Measurement location	Notes
[Roll]	[▲]	ROLL	Width of material	Max. 150 m (492.12 ft.)
[Edge]	[▼]	Edge	Front edge and width of material	Max. 150 m (492.12 ft.)
[Single]	[▶]	Single	Front edge, width, and length of material	Max. 10 m (32.80 ft.) ^{*1}

*1 Do not select this mode for the measurement of roll materials or flat materials with a length of 1.6 m (63.00 in.) or more.

MEMO

Raise the lever to suspend measurement.

RELATED LINKS

- P. 23 "Loading Roll Material"
- P. 29 "Loading Flat Material"

Remove the Material

Remove the material from the cutting machine.

Procedure

1. Raise the lever.
The pinch rollers rise up to release the material.

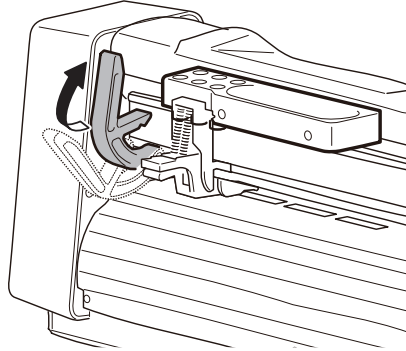

2. Remove the material from the front or rear side of the machine.

Separating Only the Cut Area

Procedure

1. Press [▲] or [▼] to feed the material to the position that you want to cut.
2. Move the safe blade along the cutting groove at the front of the cutting machine to cut off the material.

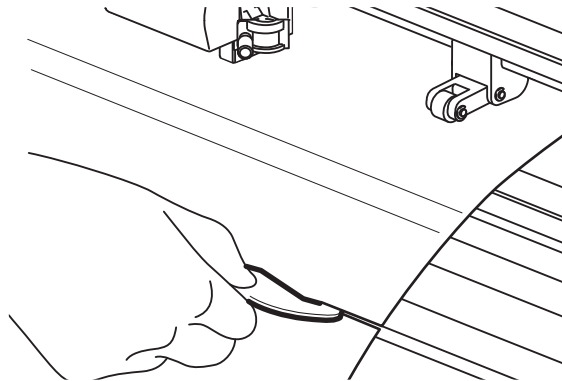

Pausing and Canceling Output

Pausing and Resuming Output

You can pause an ongoing cutting process and resume paused cutting output.

MEMO

This operation may compromise cutting quality. Do not stop the cutting process if you can avoid it.

Procedure

1. Press [PAUSE/RESUME] before printing finishes.
Cutting output pauses.
2. Press [PAUSE/RESUME] again.
The printing operation resumes.

Canceling Output

Perform the following operation to terminate cutting output while the cutting process is ongoing.

MEMO

This operation will end the job, which means that it cannot be resumed.

Procedure

1. Press [PAUSE/RESUME] before printing finishes.
2. Press [DATA CLEAR].
The screen shown below appears.

3. Press [ENTER].
Turn off the machine, and then restart it.

Cutting Output

Preparations before Cutting Output

Recommended Cutting Conditions	36
Performing a Cutting Test	37
Adjusting the Cutting Conditions.....	39
Setting the Blade Force	39
Setting the Cutting Speed	40
Setting the Blade Offset	41
Creating Cutting Data	42
Creating Cutting Lines Using a Generated Data Path	42
Creating Cutting Lines with the GreatCut-R Plug-in (Adobe Illustrator/CorelDRAW) ..	43
Creating Cutting Lines with GreatCut-R	44
Saving Cutting Data	46

Recommended Cutting Conditions

A general guide for cutting conditions for different combinations of materials and blades is given below. Before cutting, perform a cutting test with a suitable blade for the sheet material.

IMPORTANT

Blades have suitability for particular sheet materials, and cutting materials that are not specified as suitable may cause the blade to break.

Blade	Material	Cutting force (gf)	Cutting speed (cm/sec) ^{*1}	Amount of blade offset (mm)
ZEC-U5032	General Signage Vinyl	30 to 100	30 or less	0.25
	General inkjet vinyl	50 to 100		
	Iron-on print vinyl	50 to 100		
ZEC-U5025	General Signage Vinyl	40 to 100	30 or less	0.25
	Fluorescent Vinyl	120 to 200	10 or less	
ZEC-U5010	Glass (car) film	80 to 120	30 or less	0.50
ZEC-U1715	Sandblast	100 to 150	5 or less	0.25
ZEC-U3050	Coated board (thin)	200 to 350	5 or less	0.50
	Fluorescent Vinyl	350 to 450		
ZEC-U3075	Coated board (thick)	250 to 400	5 or less	0.75
	Fluorescent Vinyl	350 to 450		

*1 The faster the cutting speed, the worse the image quality, so you have to adjust the speed to match the required image quality.

MEMO

When uncut areas remain even when the blade force is increased to a value that is 50 to 60 gf higher than the values shown in this chart, replace the blade.

RELATED LINKS

- P. 37 "Performing a Cutting Test"
- P. 39 "Adjusting the Cutting Conditions"
- P. 138 "Replacing the Blade"

Performing a Cutting Test

To obtain high-quality cutting results, carry out a cutting test to check the cutting quality for the material before you perform the actual cutting. Find the appropriate settings by checking the results.

Procedure

1. Load the material and measure its size.

☛ P. 21 "Loading the Material"

2. Press [ON/OFF LINE] to switch to offline mode.
3. Press [CUT TEST].
4. Select a cutting test pattern.

Normally you select "Arrow", but if you are cutting a thick material, select "Cross".

- (1) Press [◀] or [▶] to display the screen shown below.

```
Pattern Setting
Select:◀ OK:ENTER
```

- (2) Press [ENTER].

The current pattern is displayed.

```
Pattern: Arrow
Change:▲▼ OK:ENTER
```

- (3) Press [▲] or [▼] to select a cutting test pattern.
- (4) Press [ENTER].

5. Change the scale of the pattern size.

This is set to 100% by default. Using a larger pattern size makes it easier to check the cutting test result.

- (1) Press [◀] or [▶] to display the screen shown below.

```
Ratio Setting
Select:◀ OK:ENTER
```

- (2) Press [ENTER].

The current scale of the pattern size is displayed.

```
Ratio: 100%
Change:▲▼ OK:ENTER
```

- (3) Press [▲] or [▼] to select the scale of the pattern size.
The size can be scaled from 1x to 4x.
- (4) Press [ENTER].

6. Press [◀] or [▶] to display the screen shown below.

```
Square Cut
Select:◀ OK:ENTER
```

7. Press [ENTER].

8. Press [◀], [▶], [▲] or [▼] to move the cutting carriage to the appropriate location (cutting test start position).

9. Press [ENTER].

The test pattern is cut. When the cutting test finishes, the screen shown below is displayed.

```
Continuous Square Cut
N:ONLINE OK:ENTER
```

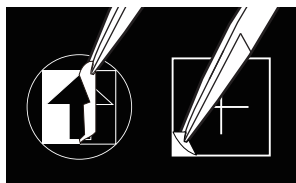

Check item	Result		Setting item	Adjustment	
Peel off the pattern	Two shapes peel off separately/Cross cutting lines are cut			Appropriate	
	Two shapes peel off together/Cross cutting lines are not cut		Cutting force	Increase	
	Some uncut areas remain.		Cutting speed	Reduce	
	Carrier paper is also cut		Cutting force	Reduce	
Pattern shape			Corners are not rounded and do not have horns		Appropriate
			Corners are rounded	Blade offset	Increase
			Corners have horns	Blade offset	Reduce
			The cut shape is distorted.	Cutting speed	Reduce

10. If the appropriate result is not achieved, adjust the necessary settings.

➤ P. 39 "Adjusting the Cutting Conditions"

11. After adjusting the settings, press [ENTER].

The test pattern is cut again. Repeat steps 9 through 11 until an appropriate cutting result is obtained.

12. Press [ON/OFF LINE] twice to switch to online mode.

RELATED LINKS

- P. 36 "Recommended Cutting Conditions"
- P. 112 "Adjusting the Cutting-in Amount"

Adjusting the Cutting Conditions

This setting enables you to make adjustments to the cutting conditions on the operation panel while checking the cutting test results. After running a cutting test, you can change the cutting conditions from the printer driver's [Printing Preferences] window (or GreatCut-R/VersaWorks).

Setting the Blade Force

If the design peels off or if the carrier paper is also cut with the material, change the blade force.

Procedure

1. Press [FORCE].

If material is loaded, press [ON/OFF LINE] to switch to offline mode.

The current blade force is displayed.

```
Force:  80 gf  ▲  
        OK:ENTER▼
```

2. Press [▲] or [▼] to change the blade force.

3. Press [ENTER] to confirm your entry.

MEMO

- Default setting: 80 gf
- Setting range: 5 to 600 gf (changeable in 5 gf increments)

RELATED LINKS

- P. 36 "Recommended Cutting Conditions"

Setting the Cutting Speed

If the design peels off or if the cut lines are not clean, reduce the cutting speed. When the cutting speed is too fast, extra load is applied to the material, which can move the material up and down during cutting. Also reduce the cutting speed in such cases. The cutting speed and quality mutually affect each other. Therefore, use a cutting speed within the range that can maintain cutting quality while selecting cutting quality that matches the cutting speed.

Procedure

1. Press [SPEED].

If material is loaded, press [ON/OFF LINE] to switch to offline mode.

The current cutting speed is displayed.

```
Speed: 72 cm/s ▲  
Select:◀ OK:ENTER▼
```

2. Press [▲] or [▼] to change the cutting speed.

3. Press [ENTER] to confirm your entry.

The current cutting quality is displayed.

```
Quality: Normal ▲  
Select:◀ OK:ENTER▼
```

4. Press [▲] or [▼] to set the quality.

Quality improves in this order: "Draft", "Fair", "Normal", "Fine", and "Small Letter". Normally, quality is set to "Normal". If you need to cleanly cut small text or complex graphics, select "Small Letter".

5. Press [ENTER] to confirm your entry.

6. Press [ON/OFF LINE] to go back to the original screen.

MEMO

- [SPEED]
Default setting: 72 cm/s (28.34 in./s)
Setting range: 3 to 153 cm/s (1.18 to 60.23 in./s) (changeable in 3 cm/s [1.18 in./s] increments)
- Quality: "Normal"

RELATED LINKS

- P. 36 "Recommended Cutting Conditions"
-

Setting the Blade Offset

Set the blade offset. Enter the listed offset value for the blade. When using the included blade, cutting can be performed using the factory-default settings.

MEMO

If the beginning of a cut deviates from the intended location or if the corners of a shape are not clean, adjust the offset value.

Procedure**1.** Press [OFFSET].

If material is loaded, press [ON/OFF LINE] to switch to offline mode.

The current offset value is displayed.

```
Offset:  0.25 mm ▲  
        OK:ENTER ▼
```

2. Press [▲] or [▼] to change the offset value.**3.** Press [ENTER] to confirm your entry.**MEMO**

- Default setting: 0.250 mm (0.010 in.)
- Setting range: 0.000 to 1.000 mm (0.000 to 0.040 in.)

RELATED LINKS

- P. 36 "Recommended Cutting Conditions"
-

Creating Cutting Data

In existing cutting data, create cutting lines used by the machine to identify where to cut.

Creating Cutting Lines Using a Generated Data Path

Paths created in illustration software (such as Adobe Illustrator) are recognized as cutting lines.

Procedure

1. Start the application with which you created the cutting data.
2. Open the data for cutting.
3. Select the data path and copy it.

If the application has a layer function, create a new layer and copy it.

MEMO

The path to be copied should have a gap of around 1 mm (0.04 in.) outside (inside, when creating a cutting line inline) of the vector line of the original data.

4. Change the line width of the copied path to 0.001 mm (0.04 mil).

The copied path will be recognized as the cutting line.

MEMO

When setting the cutting line to be perforated, set the line color to green (R: 0 G: 255 B: 0).

Creating Cutting Lines with the GreatCut-R Plug-in (Adobe Illustrator/CorelDRAW)

This section explains how to use mainstream illustration software Adobe Illustrator (Adobe Illustrator 2020) or CorelDRAW (CorelDRAW 2020) to create cutting lines with the GreatCut-R plug-in.

Procedure

1. Start Adobe Illustrator or CorelDRAW.
2. Click [File]>[Open] to open the data for cutting.
3. Select the object for which you want to create cutting lines using the selection tool.
4. Open the window for setting the cutting lines.
 - Adobe Illustrator: Click [File]>[GreatCut-R]>[Create Contour] or [Create outline].

MEMO

- Only [Create Contour] is available for raster data.
- For the difference between contour lines and outlines and details on these settings, refer to the GreatCut-R online help.

5. Set the conditions for the cutting lines to be created.

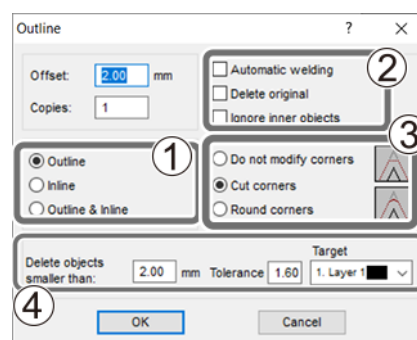
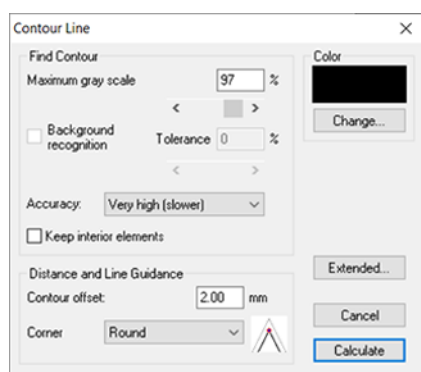

[Contour Line] window		[Outline] window	
[Maximum gray scale]	To clarify the borders on which the cutting lines are created, a higher gradation value should be used for the object and background.	[Offset]	Enter the distance from the object.
[Accuracy]	Select the accuracy level.	[Copies]	Enter the number of cutting lines to be created with the offset value.
[Contour offset]	Enter the distance from the object.	①	Select the position of cutting lines to be created for the object.
[Corner]	Select how to process the corners of cutting lines.	②	Select how to create the cutting lines.
[Color]	Select the color to assign to the cutting lines.	③	Select how to process the corners of cutting lines.
[Extended]	Click this button to set the cutting lines in more detail.	④	If the distance between the ends of an open path is less than or equal to the entered value, a merged outline is created in the specified layer.

6. Click [Calculate] or [OK].

The cutting lines are created for the object.

Creating Cutting Lines with GreatCut-R

Import data into GreatCut-R and create cutting lines. For basic operations and other information on GreatCut-R, refer to the GreatCut-R online help.

Procedure

1. Start GreatCut-R.
2. Display the cutting data on the GreatCut-R work screen.
 - GreatCut-R format file:
Select the cutting data from [File]>[Open], and then click [Open].
 - Other files:
Select the cutting data from [File]>[Import], and then click [Open].

MEMO

CorelDRAW format files cannot be imported into GreatCut-R. Open the target cutting data in CorelDRAW and click  on the menu bar.

3. Select the object for which you want to create cutting lines.
4. Click [Tools]>[Contour Line] or [Outline].
The [Contour Line] window or the [Outline] window appears.

MEMO

- Only [Contour Line] is available for raster data.
- For the difference between contour lines and outlines and details on these settings, refer to the GreatCut-R online help.

5. Set the conditions for the cutting lines to be created.

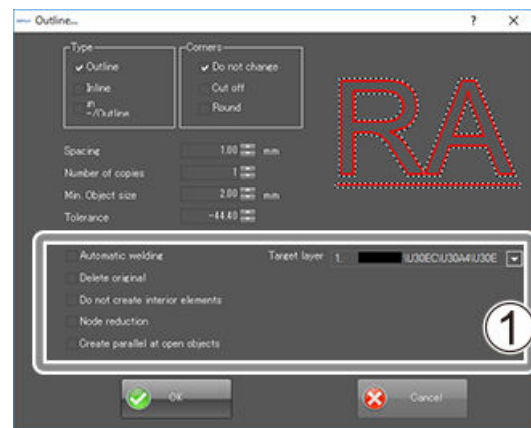
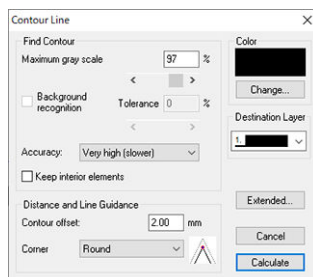

[Contour Line] window		[Outline] window	
[Maximum gray scale]	To clarify the borders on which the cutting lines are created, a higher gradation value should be used for the object and background.	[Type]	Select the position of cutting lines for the object.
[Accuracy]	Select the accuracy level.	[Corners]	Select how to process the corners of cutting lines.
[Contour offset]	Enter the distance from the object.	[Spacing]	Enter the distance from the object.
[Corner]	Select how to process the corners of cutting lines.	[Number of copies]	Enter the number of cutting lines created with the offset value.

[Contour Line] window		[Outline] window	
[Color]	Select the color to assign to the cutting lines.	[Min. Object size]	Specify the size of the smallest object for which you want to create cutting lines.
[Destination layer]	Select the layer in which to create the cutting lines.	[Tolerance]	Enter the allowable value for corner processing specified for the cutting lines.
[Extended]	Click this button to set the cutting lines in more detail.	①	Select the processing of the created cutting lines and objects and the layer to save.*1

*1 For details, refer to the GreatCut-R online help.

6. Click [Calculate] or [OK].

The cutting lines are created for the object.

Saving Cutting Data

Cutting data can be saved in the file format of the software used to create cutting lines.

Procedure

1. Click [File]>[Save] (or [Save]) to save data.

GreatCut-R cutting data can be saved in CCJ format as a GreatCut-R job or in JRF format as a Reference job, which saves job information such as cutting conditions and output driver.

MEMO

The first time a file is saved in GreatCut-R, the [JOB Information] dialog box opens for database management of cutting data. Enter the necessary information in this window and click [OK]. If database management is not necessary, select [Cancel].

Basic Cutting

Setting the Output-start Location	48
Performing Cutting	49
Sending Adobe Illustrator Cutting Jobs from the Printer Driver	49
Sending CorelDRAW Cutting Jobs from the Printer Driver	52
Sending Cutting Jobs from GreatCut-R	54

Setting the Output-start Location

Set the cutting start position as the origin at the right edge of the output area. You can cut without setting the origin, but setting the output area allows you to use material without being wasteful, and also to cut targeted locations.

Procedure

1. Check that the material has been properly loaded and set up.
2. Press [◀], [▶], [▲] or [▼] to move the cutting carriage to the location you want to set as the origin.

MEMO

The origin point can be set in either online mode or offline mode.

3. Press [ENTER].

The origin point (cutting start location) is set.

RELATED LINKS

- P. 21 "Loading the Material"
-

Performing Cutting

Send a cutting job to the machine to start cutting.

MEMO

If the material comes loose or the machine operates unusually, press [PAUSE/RESUME] to cancel output. Then reload the material, starting over from the beginning.

RELATED LINKS

- P. 33 "Canceling Output"
 - P. 21 "Loading the Material"
-

Sending Adobe Illustrator Cutting Jobs from the Printer Driver

Check that the machine is in online mode and start cutting.



WARNING

Never touch the cutting carriage while output is in progress.

The cutting carriage moves at high speed. Coming into contact with the moving carriage may cause injury.

Procedure

1. Start Adobe Illustrator.
2. Click [File]>[Open] to select cutting data that includes cutting lines.
3. Click [File]>[Print].
The [Print] window appears.
4. Set up the job to be output to the machine.

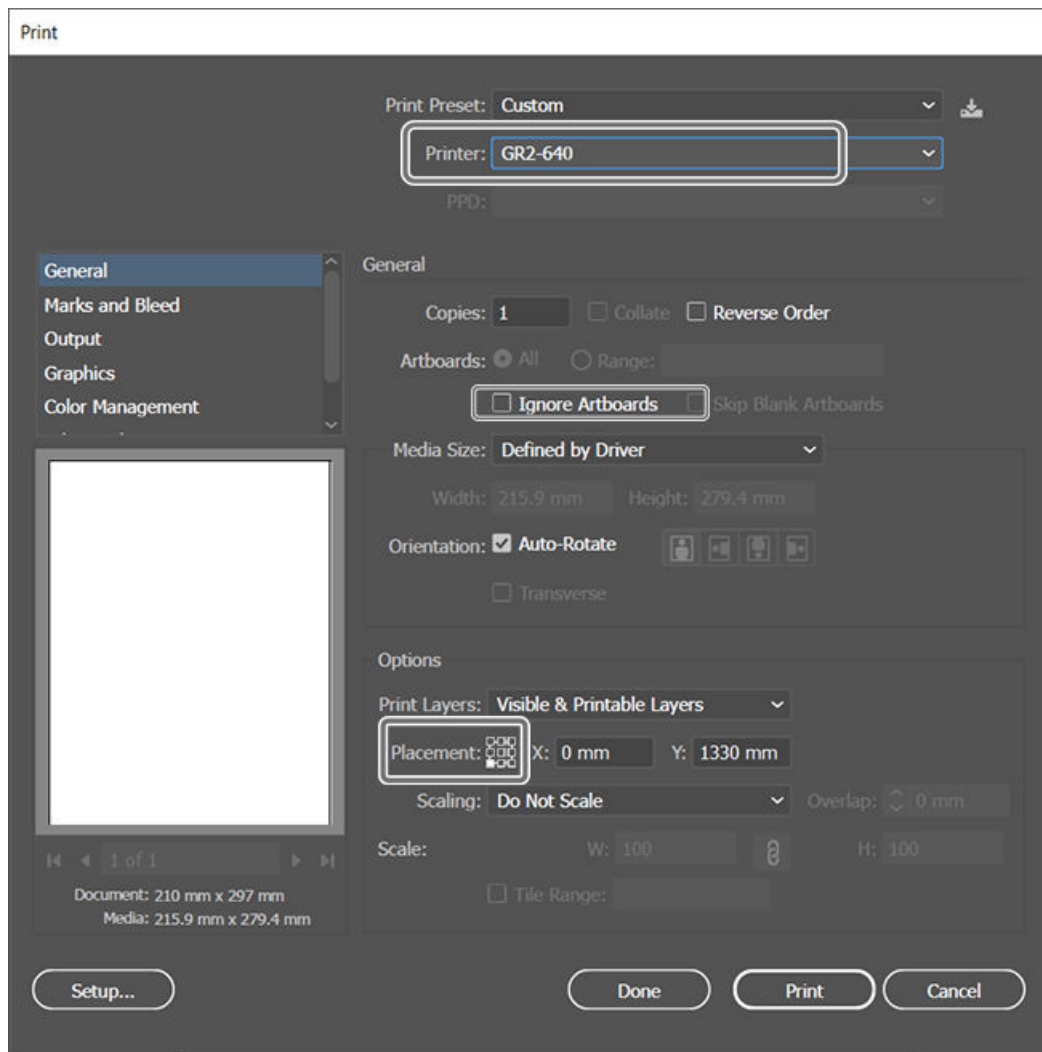

Setting item	Settings	Notes
[Printer]	Select the machine model.	
[Artboards]	Select the [Ignore Artboards] check box.	Clear this check box if the artboard size is suited to the cutting data.
[Placement]	Select the lower-left point.	

5. Press [Setup].
The [Print] window appears.
6. Click [Preferences].
The [Printing Preferences] window appears.

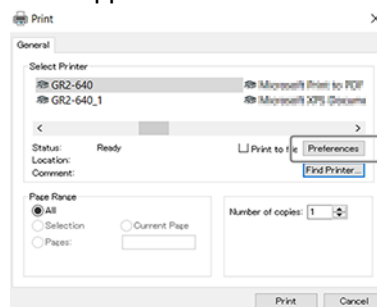

7. Select the [Cutter] tab and change the cutting conditions (①).
If necessary, configure the other cutting settings (②).

If you have saved presets, you can load a preset and apply cutting conditions.



8. Switch to the [Paper] tab and enter the size of the loaded material (X: length/Y: width) under [Paper Size].

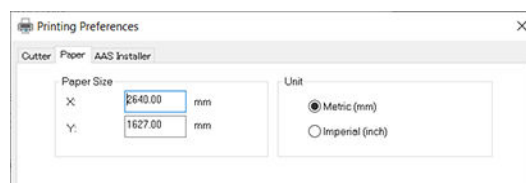

9. Click [OK] to close the [Printing Preferences] window.
10. In the [Print] window, click [Print].
11. In the [Print] window, click [Done].
12. Click [File]>[Print] to open the [Print] window again.
Using the preview, check that the cutting data is displayed at the bottom left.
13. Click [Print].
The cutting job is sent to the machine.

RELATED LINKS

- P. 32 "Remove the Material"
- P. 83 "Setting Up Section Cutting"
- P. 84 "Setting Up Perforated Cutting Using the Printer Driver"
- P. 109 "Setting Overlap Cutting Using the Printer Driver"
- P. 122 "Loading and Applying a Preset"

Sending CorelDRAW Cutting Jobs from the Printer Driver

Check that the machine is in online mode and start cutting.

⚠ WARNING Never touch the cutting carriage while output is in progress.
The cutting carriage moves at high speed. Coming into contact with the moving carriage may cause injury.

Procedure

1. Start CorelDRAW.
2. Click [File]>[Open] to select cutting data that includes cutting lines.
3. Click [File]>[Print].
The [Print] window appears.
4. Select the [General] tab and select this machine model for [Printer].

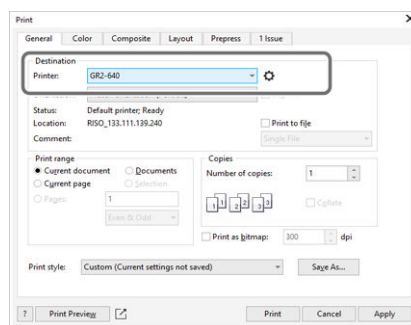

5. Click .
The [Printing Preferences] window appears.
6. Select the [Cutter] tab and change the cutting conditions (①).
If necessary, configure the other cutting settings (②).
If you have saved presets, you can load a preset and apply cutting conditions.



7. Switch to the [Paper] tab and enter the size of the loaded material (X: length/Y: width) under [Paper Size].

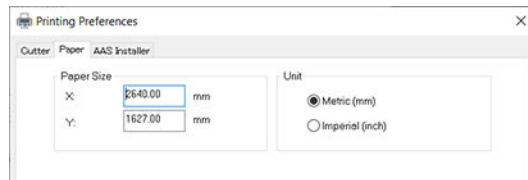

8. Click [OK] to close the [Printing Preferences] window.
9. Switch to the [Color] tab in the [Print] window and select this machine model for [Color conversions].

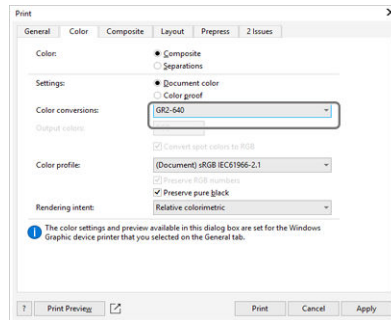

10. Switch to the [Layout] tab and select [Bottom left corner] for [Reposition artwork to].

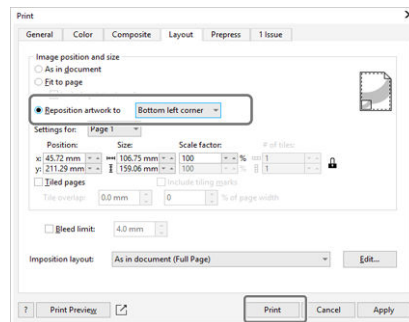

11. Click [Print].
The cutting job is sent to the machine.

RELATED LINKS

- P. 32 "Remove the Material"
- P. 83 "Setting Up Section Cutting"
- P. 84 "Setting Up Perforated Cutting Using the Printer Driver"
- P. 109 "Setting Overlap Cutting Using the Printer Driver"
- P. 122 "Loading and Applying a Preset"

Sending Cutting Jobs from GreatCut-R

Check that the machine is in online mode and start cutting.

⚠ WARNING **Never touch the cutting carriage while output is in progress.**
 The cutting carriage moves at high speed. Coming into contact with the moving carriage may cause injury.

MEMO
 If the cutting setting is "Accept setup command" and the cutting job is output from GreatCut-R, the cutting conditions set using GreatCut-R are applied. The printer driver's cutting settings are not applied.

Procedure

1. Start GreatCut-R.
2. Display cutting data, which includes the cutting lines, on the GreatCut-R work screen.
 - GreatCut-R format file:
 Select the cutting data from [File]>[Open], and then click [Open].
 - Other files:
 Select the cutting data from [File]>[Import], and then click [Open].

MEMO
 CorelDRAW format files cannot be imported into GreatCut-R. Open the target cutting data in CorelDRAW and click  on the menu bar.

3. Click [File]>[Output].
 The [Output to device] window appears.
4. Set up the job to be output to the machine.

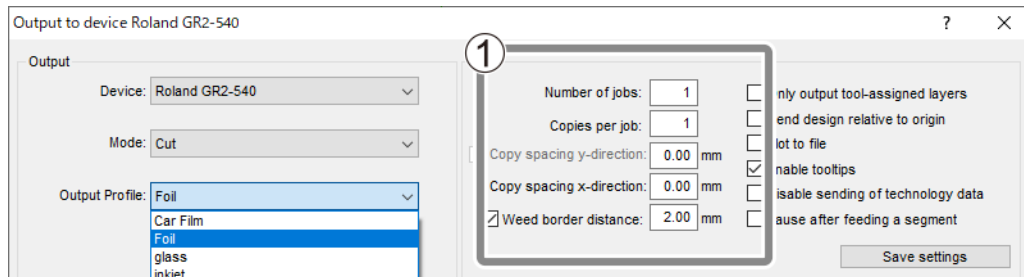

Setting item	Setting details	Notes
[Device]	Set the output device.	Select the machine model.
[Mode]	[Cut with AAS]/[Cut]/[FlexCut]	[Cut with AAS]: For printing and cutting [Cut]: For cutting only [FlexCut]: For perforated cutting
[Output Profile]	[Foil] ^{*1}	
①	Output/save method	Configure these settings according to the cutting job to output.

*1 The first time you perform this action, select the [Foil] saved as default, and after saving some settings as presets, select the profile to use as reference for the material to be cut.

5. Click the parameter values to edit cutting conditions.
 If [Mode / Tool] is set to [Defalut] in the [Layer Settings] window, the values of cutting conditions set here are applied.

MEMO
 • [Speed] can be changed in 3 cm/s (1.18 in./s) increments.

- Enter 1 in [Step count]. The value entered here is the number of times of cutting in the same location (overlap cutting).

Output to device Roland GR2-640

Output

Device: Roland GR2-640

Mode: Cut

Output Profile: Foil

Manage Profiles ...

Number of jobs: 1

Copies per job: 1

Copy spacing y-direction: 5.00 mm

Copy spacing x-direction: 2.00 mm

Weed border distance: 2.00 mm

Parameter	Value
Pressure [g]	50
Speed [cm/s]	108
Material width [mm]	470.38
Length [mm]	30000.00
Step count	1

6. Click [Read material size] to import the size of the material loaded in the machine.

Accuracy: Normal

Origin: New origin

Objects: All objects

Job will be segmented!

Preview... Output Read material size Test drive Cancel

MEMO

To return the cutting carriage to the set origin after cutting is finished, set [Origin] to [Don't set].

Accuracy: Normal

Origin: Don't set

Test drive

Output Read material size Cancel

7. Click [Output].

The cutting data is sent to the machine and cutting starts.

MEMO

When the cutting data is too large to fit in the material to use, the following window opens. Set the method for dividing the cutting data for cutting on the material, and then click [OK].

Select how to divide the material for the cutting data, and then set inner margins so that no gap is left in the borders (in the X and Y directions) of the divided cutting data.

Segmentation ? X

Optimize material: max. size + last segment smallest

Optimize material: max. size + first segment smallest

Minimize cut through (Smartfeed)

Optimize segments (segments of equal size)

Pre-saved segmentation

Reverse cutting

X Overlap: 0.00 mm

Y Overlap: 0.00 mm

OK Cancel

RELATED LINKS

- P. 86 "Setting Up Perforated Cutting with GreatCut-R"
 - P. 104 "Setting the Weed Border"
 - P. 110 "Setting Up Overlap Cutting with GreatCut-R"
 - P. 124 "Saving Presets with GreatCut-R"
-

Basic Printing and Cutting

Automatic Aligning System (AAS)	58
Crop Mark Types	58
Setting the Margins and the Distance between Crop Marks	61
Automatic Detection of Material Feed Direction	62
Setting the AAS Detection Mode	63
Setting Crop Marks in Cutting Data	64
Setting Crop Marks with the AAS Plug-in (Adobe Illustrator)	64
Setting Crop Marks with the AAS Plug-in (CorelDRAW)	66
Setting Crop Marks with the GreatCut-R Plug-in (Adobe Illustrator/CorelDRAW)	68
Setting Crop Marks with GreatCut-R	69
Printing Cutting Data on Material	71
Printing Cutting Data from GreatCut-R	71
Setting the Output-start Location (Printing and Cutting)	73
Performing Cutting	74
Sending Adobe Illustrator Cutting Jobs from the Printer Driver	74
Sending CorelDRAW Cutting Jobs from the Printer Driver	77
Sending Cutting Jobs from GreatCut-R	79

Automatic Aligning System (AAS)

To use this machine for printing and cutting material with cutting data printed, you must perfectly align the printed graphics and the cutting positions. The crop marks digitally generated around the graphics can be automatically detected for accurate alignment. In this manual, this feature is called AAS.

Crop Mark Types

Cutting job functions, the shape of four corners, and the job output source differ depending on crop marks generated by the AAS plug-in or GreatCut-R plug-in. Select the method to generate crop marks based on factors such as the cutting data and time required for cutting.

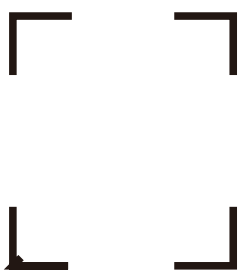
	AAS plug-in	GreatCut-R plug-in (GreatCut-R)
Cutting data output	Printer driver	GreatCut-R
Crop mark shape		
Automatic Detection of Material Feed Direction	✓	x
Multiple cutting	✓	x
Section Cutting	✓	x
Crop mark generation target	Page*1/Object	Object

*1 Crop marks are generated in the four corners of a cutting data page (inside the space with sufficient length for material feeding).

MEMO

Crop marks are created on the selected object or page (work page for cutting data). When creating crop marks on an object, you can set up three different types of crop marks suitable for the cutting data.

Four-point

This type of crop mark is the basic crop marks created in the four corners of the selected object. The settings for four-point crop marks are applied to all crop marks. These crop marks are used to set up crop marks for each page instead of in an object.

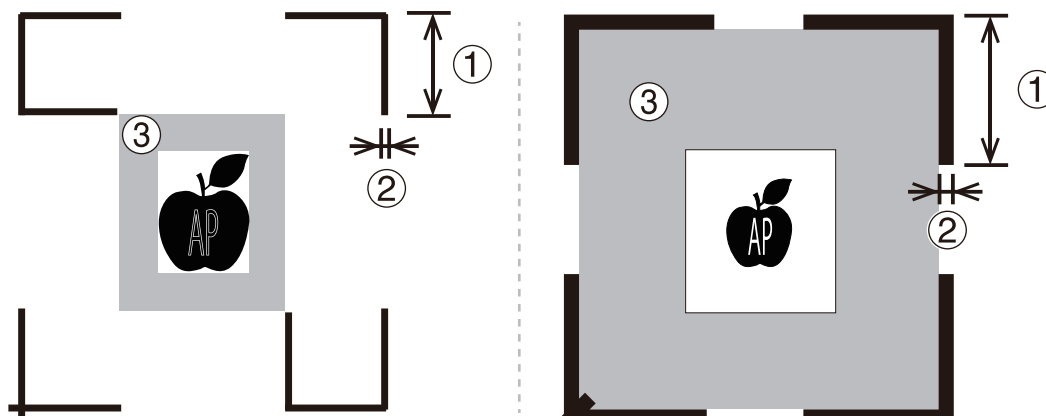

Set the size (length) and line width of the crop marks, as well as their margins from the object, within the range below.

	Setting item	Setting range	Recommended value
①	Length	5 to 50 mm (0.2 to 1.96 in.)	25 mm (0.98 in.)
②	Thickness	1 to 2 mm (0.04 to 0.07 in.)	1 mm (0.04 in.)
③	Margin	0 to 50 mm (0 to 1.96 in.)	5 mm (0.2 in.)

Segmental

Segmentation allows for correction of warpage that occurs when cutting long materials and scans the material in sections when section cutting is used. This type of crop mark is best used for long printed materials. Intermediate crop marks are added between four-point crop marks at distances specified in X (feed direction) and Y (width), respectively, from the crop mark origin (①).

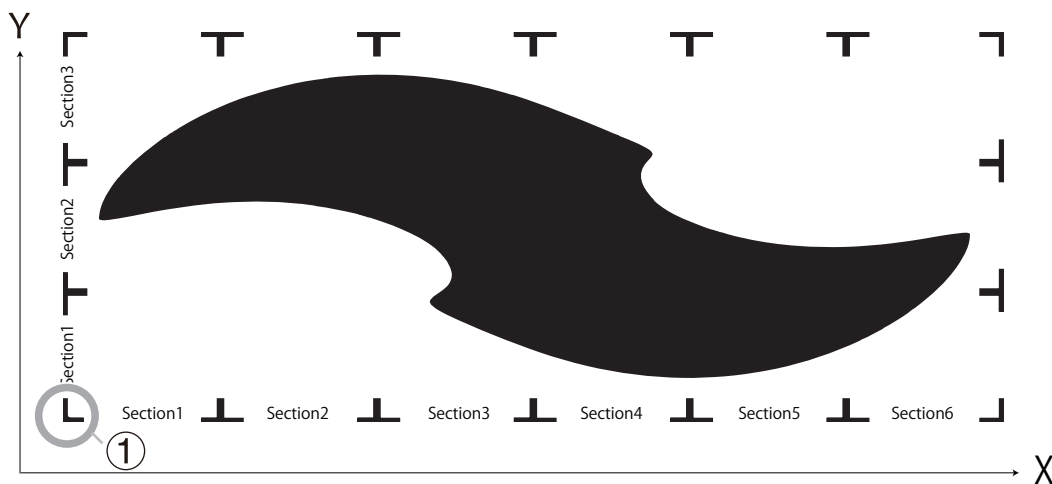
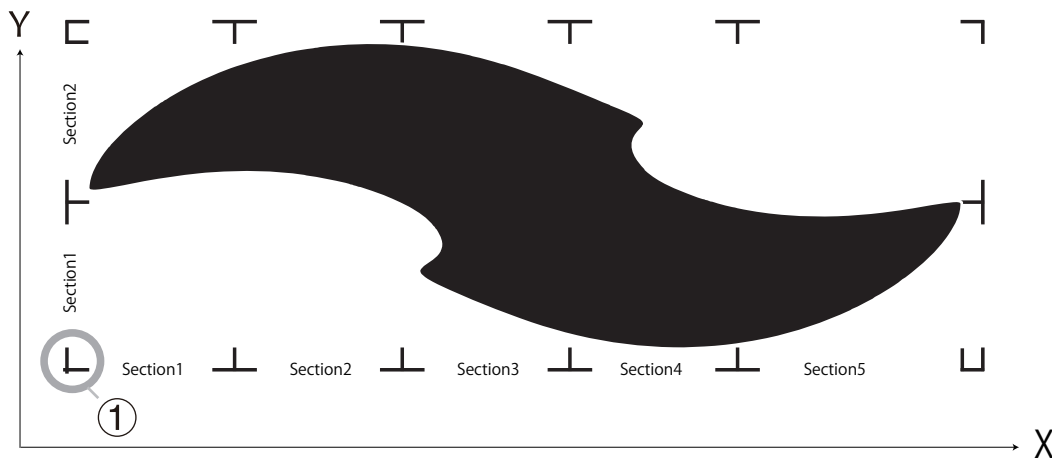

	AAS plug-in setting range	GreatCut-R plug-in setting range
X: feed direction	50 to 600 mm (1.97 to 23.62 in.)	200 to 600 mm (7.88 to 23.62 in.)
[Y] Width of material	200 to 600 mm (7.88 to 23.62 in.)	200 to 600 mm (7.88 to 23.62 in.)

Multiple

Based on the four-point crop mark settings, crop marks can be set by specifying the number of duplicates and the main direction (X and Y directions). This operation sets one crop mark to the selected objects at once, which is recommended for multiple cutting of complex objects.

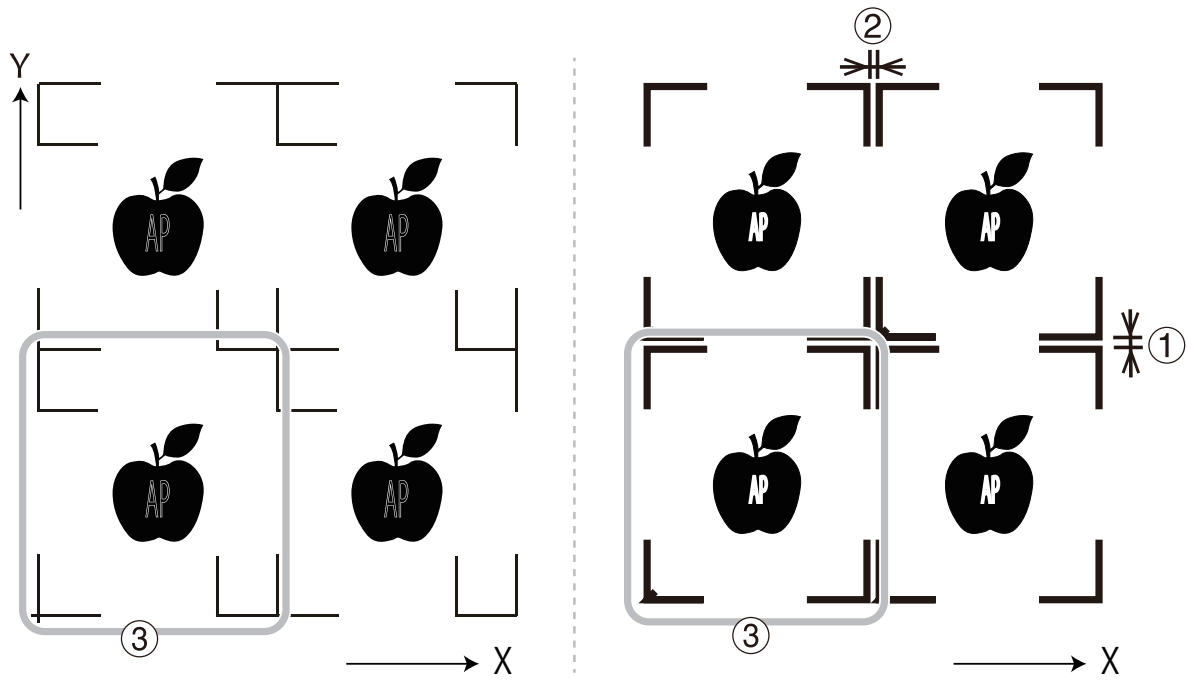

①	Space between crop marks duplicated in the Y direction (Use GreatCut-R plug-in or GreatCut-R for setup)
②	Space between crop marks duplicated in the X direction (Use GreatCut-R plug-in or GreatCut-R for setup)
③	Source data

Setting the Margins and the Distance between Crop Marks

The working area and necessary margins when using crop marks are described below.

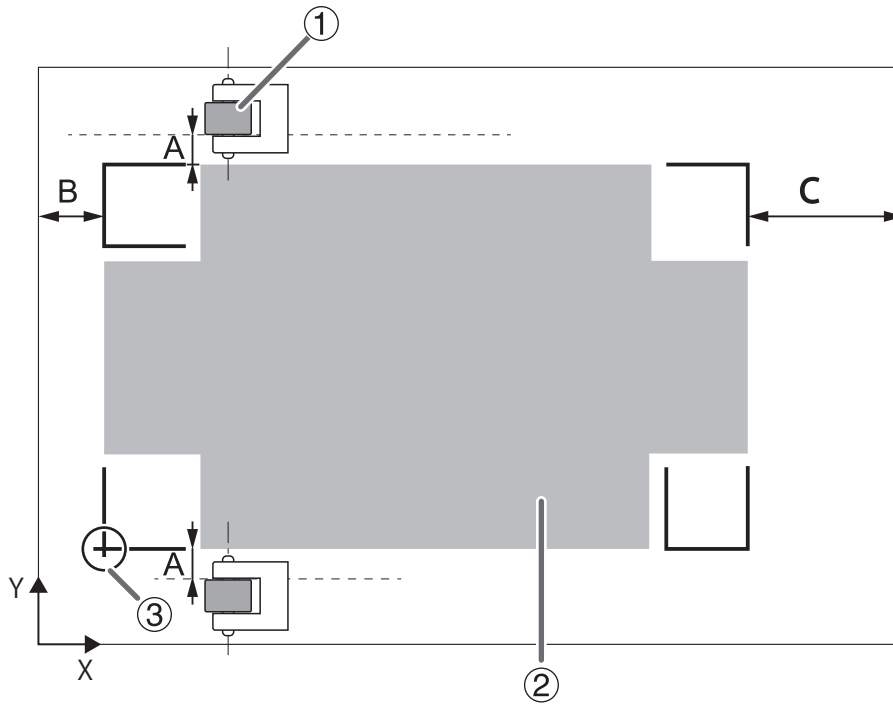

①	Pinch roller
②	Working area
③	Crop mark origin
A	10 mm (0.4 in.)
B	20 mm (0.8 in.)
C	Min. 80 mm (3.15 in.)/50 mm (1.97 in.)* ¹

*1 When extended in the feed direction (length)

Automatic Detection of Material Feed Direction

Normally you load the material with the crop mark origin at the front right of the cutting machine. If crop marks are set up using the AAS plug-in, the material feed direction is recognized as correct even when the material is loaded in reverse direction, and the material is cut according to the contour line of the print.

MEMO

The cutting order is detected by a sensor according to the shape of each crop mark created at the four corners. Automatic detection of material feed direction only supports 180-degree orientations.

Normally, the machine reads the crop marks in the order of 1 (crop mark origin), 2, 3, and finally 4.

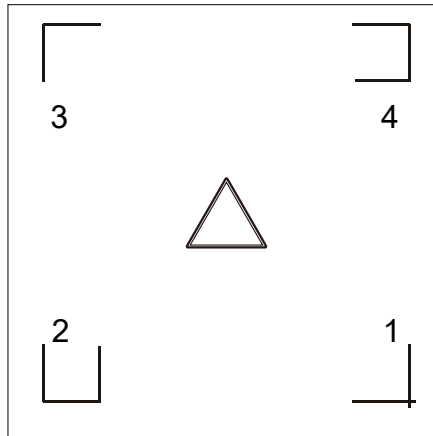

Crop marks on material loaded in reverse direction (rotated) will be read in the order of 3, 4, 1 (crop mark origin), and 2. The feed direction is detected when the fourth crop mark is read, and the information is sent to the driver.

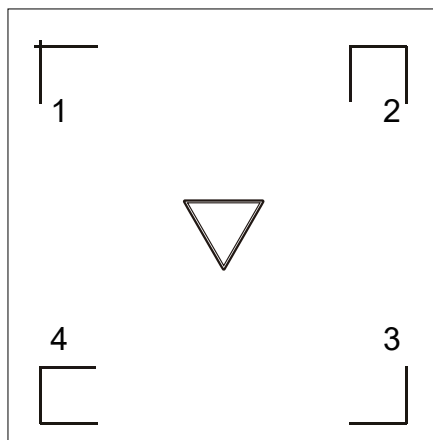

Setting the AAS Detection Mode

Normally the crop mark origin is set at the front right, facing the machine, but when crop marks are set up using the AAS plug-in, you can specify the reading direction of the crop marks for the loaded material.

Procedure

1. Press [MISC].
If material is loaded, press [ON/OFF LINE] to switch to offline mode.
2. Press [▶] to display the screen shown below.

```
AAS detect mode
Select:◀ OK:ENTER
```

3. Press [ENTER].
The current setting is displayed.
4. Press [▲] or [▼] to set the material detection mode.

<pre>Auto detection Change:▲▼ OK:ENTER</pre>	Detect upon rotating (by 180 degrees) according to the orientation of the crop marks printed on the material
<pre>Reverse derection Change:▲▼ OK:ENTER</pre>	Detect from reverse direction (rear)
<pre>Forward derection Change:▲▼ OK:ENTER</pre>	Detect from front

5. Press [ENTER].
6. Press [ON/OFF LINE] to go back to the original screen.

MEMO

Default setting: [Auto detection]

RELATED LINKS

- P. 62 "Automatic Detection of Material Feed Direction"

Setting Crop Marks in Cutting Data

To accurately read the cutting data positions printed on the material, set AAS-compatible crop marks. Use appropriate crop marks according to your application.

Setting Crop Marks with the AAS Plug-in (Adobe Illustrator)

If you are using section cutting or automatic material feed direction detection, set up crop marks with the AAS plug-in before sending the cutting job to the machine from Adobe Illustrator.

Procedure

1. Start Adobe Illustrator.
2. Click [File]>[Open] to select cutting data that includes cutting lines.
You do not need to select cutting data when setting up crop marks on a page.
3. Click [File]>[Script]>[RolandDG_AASII_Mark].
The crop mark setting window appears.

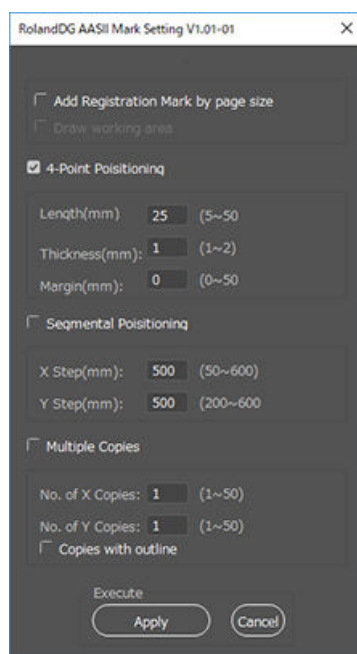

4. Select the mode of crop mark creation.

Settings	Crop marks
[Add Registration Mark by page size]	Set crop marks on page
[4-Point Positioning]	Four-point
[Segmental Positioning]	Segmental
[Multiple Copies]	Multiple

5. Enter setting values for the selected type of crop mark.

The setting values for four-point crop marks are applied to all crop marks.

- Set the four-point crop marks.

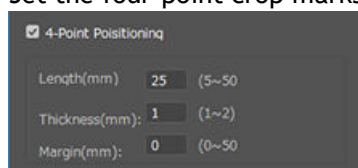

- Set the segmental crop marks.

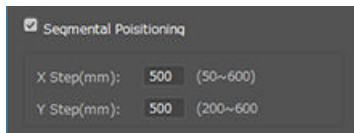

- Set the crop marks for multiple copies.

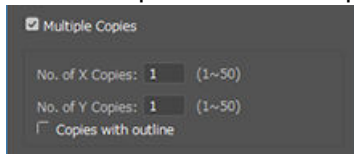

To display cutting lines on duplicated data, select the [Copies with outline] check box.
You cannot select [Multiple Copies] when creating crop marks on a page.

6. Click [Apply].

MEMO

To edit crop marks, click [Cancel] in the crop mark setting window or remove the lock on the layer in which crop marks are created and delete the crop marks.

RELATED LINKS

- P. 58 "Crop Mark Types"
-

Setting Crop Marks with the AAS Plug-in (CoreIDRAW)

If you are using section cutting or automatic material feed direction detection, set up crop marks with the AAS plug-in before sending the cutting job to the machine from CoreIDRAW.

Procedure

1. Start CoreIDRAW.
2. Click [File]>[Open] to select cutting data that includes cutting lines.
You do not need to select cutting data when setting up crop marks on a page.
3. Click [Tools]>[Scripts]>[Run Script].
The [Run Macro] window appears.
4. Select [GlobalMacros (RolandDG_AASII_Markgms)] from [Macro in].

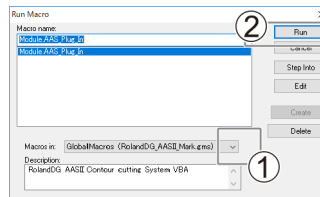

5. Click [Run].
The crop mark setting window appears.

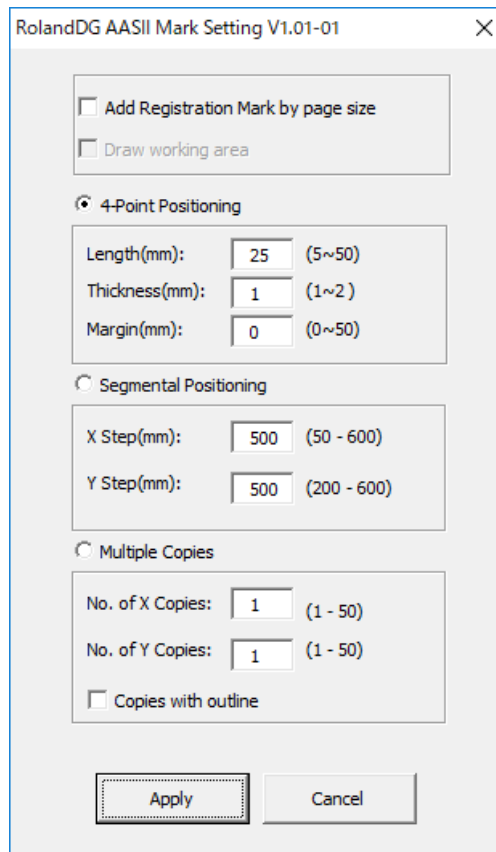

6. Select the mode of crop mark creation.

Settings	Crop marks
[Add Registration Mark by page size]	Set crop marks on page
[4-Point Positioning]	Four-point

Settings	Crop marks
[Segmental Positioning]	Segmental
[Multiple Copies]	Multiple

7. Enter setting values for the selected type of crop mark.

The setting values for four-point crop marks are the basic settings for crop marks.

- Set the four-point crop marks.

4-Point Positioning

Length(mm): (5~50)

Thickness(mm): (1~2)

Margin(mm): (0~50)

- Set the segmental crop marks.

Segmental Positioning

X Step(mm): (50 - 600)

Y Step(mm): (200 - 600)

- Set the crop marks for multiple copies.

Multiple Copies

No. of X Copies: (1 - 50)

No. of Y Copies: (1 - 50)

Copies with outline

To display cutting lines on duplicated data, select the [Copies with outline] check box.

You cannot select [Multiple Copies] when creating crop marks on a page.

8. Click [Apply].

MEMO

To edit crop marks, click [Cancel] in the crop mark setting window or remove the lock on the layer in which crop marks are created and delete the crop marks.



RELATED LINKS

- P. 58 "Crop Mark Types"

Setting Crop Marks with the GreatCut-R Plug-in (Adobe Illustrator/CorelDRAW)

Set up crop marks in cutting data using the GreatCut-R plug-in. After setup, output the cutting data from GreatCut-R.

Procedure

1. Start Adobe Illustrator or CorelDRAW.
2. Click [File]>[Open] to select cutting data that includes cutting lines.
3. Display the crop mark setting window.
 - Adobe Illustrator: Click [File]>[GreatCut-R]>[Settings].
 - CorelDRAW: Click  on the menu bar.
4. Click  for [Jog marks] and set the crop mark conditions.
 - [Type]: Roland DG(AASII)
 - Set the basic four-point crop marks and enter the distance to be used for creating crop marks.

MEMO

Intermediate crop marks are set up in the cutting data once the relevant value exceeds the set distance. This means that segmental crop marks are created automatically based on the cutting size in the cutting data.

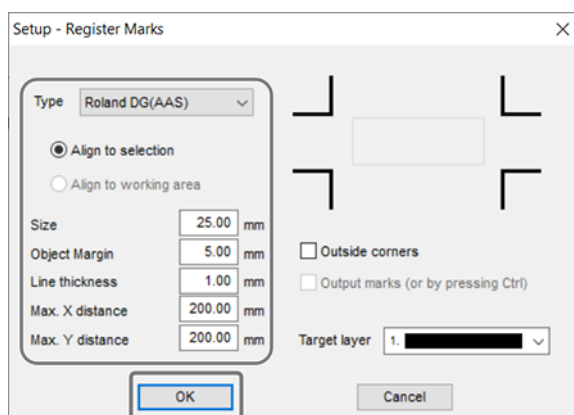

5. Click [OK] to close all of the open setting windows.
6. Select cutting data that includes cutting lines.
7. Create crop marks on the object.
 - Adobe Illustrator: Click [File]>[GreatCut-R]>[Add jog marks].
 - CorelDRAW: Click  on the menu bar.

MEMO

For cutting output, select the cutting data (object including cutting lines) and crop marks, and send them to GreatCut-R. GreatCut-R will start up, displaying the cutting data on the work screen.

- When using Adobe Illustrator: Click [File]>[GreatCut-R]>[Cut].
- When using CorelDRAW: Click  on the menu bar.

RELATED LINKS

- P. 58 "Crop Mark Types"

Setting Crop Marks with GreatCut-R

Using GreatCut-R, set up crop marks in cutting data that includes cutting lines.

Procedure

1. Start GreatCut-R.
2. Display cutting data, which includes the cutting lines, on the GreatCut-R work screen.
 - GreatCut-R format file:
Select the cutting data from [File]>[Open], and then click [Open].
 - Other files:
Select the cutting data from [File]>[Import], and then click [Open].

MEMO

CorelDRAW format files cannot be imported into GreatCut-R. Open the target cutting data in CorelDRAW and click  on the menu bar.

3. Select cutting data that includes cutting lines.
4. Click [Settings]>[Standard Settings]>[Register/ Crop Marks].
The crop mark setting window appears.
5. Set the crop mark conditions.
 - [Type]: Roland DG(AAS)
 - [Alignment]: Selects the crop mark creation target.
 - [Target layer]: Selects the color of the layer in which to create crop marks.
 - Set the basic four-point crop marks and enter the distance to be used for creating crop marks.

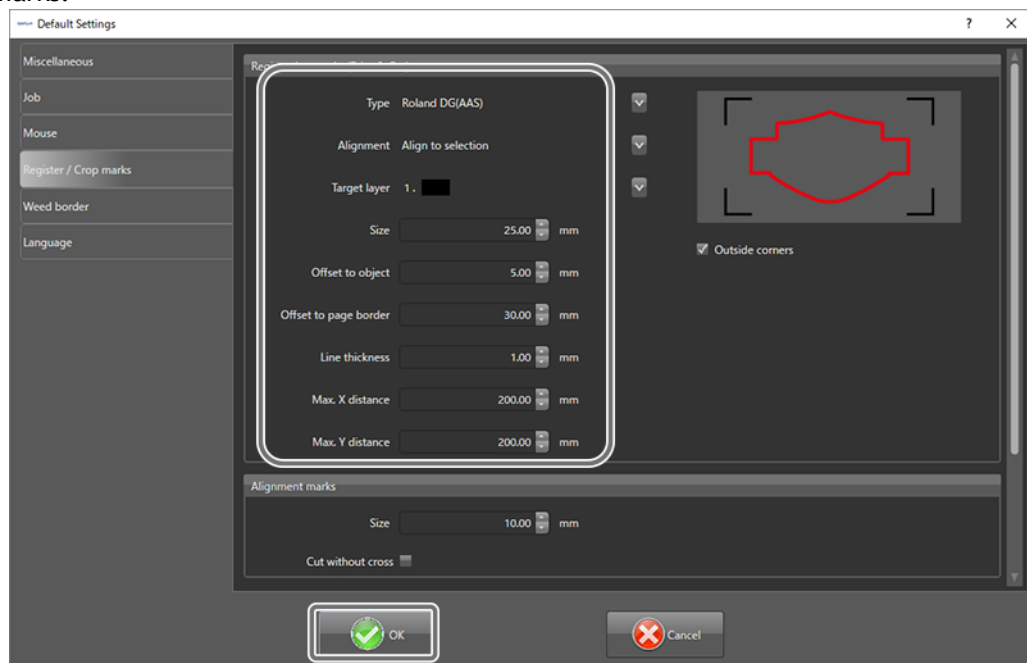

6. Click [OK].
7. Select cutting data that includes cutting lines.
8. Click [Tools]>[Set Register Marks].
Crop marks are generated around the cutting data based on the conditions set.

RELATED LINKS

- [P. 58 "Crop Mark Types"](#)
-

Printing Cutting Data on Material

Use your printer to print cutting data with crop marks set up. This section assumes that you are already familiar with how to print to material from Adobe Illustrator or CorelDRAW.

IMPORTANT

Pay attention to the following points before printing cutting data:

- You must use a laser or inkjet printer with a resolution of 720 dpi or greater.
- Print on white material. Crop marks cannot be detected on transparent or colored material.
- Print crop marks clearly in black.
- When printing crop marks on material, make sure to include appropriate margins on all sides in the cutting area.
- Print cutting data on material without changing the scale.

Printing Cutting Data from GreatCut-R

Procedure

1. Load the material in the printer.

For more information on how to operate the printer, refer to the printer's documentation.

2. Display the cutting data that includes crop marks and cutting lines on the GreatCut-R work screen.

- GreatCut-R format file: Click **[File]>[Open]** and select the cutting data.
- Other files:

Select the cutting data from **[File]>[Import]**, and then click **[Open]**.

MEMO

CorelDRAW format files cannot be imported into GreatCut-R. Open the target cutting data in CorelDRAW and

click  on the menu bar.

3. Click [File]>[Print].

The **[Print]** window appears.

4. Select the printing conditions for the printer, and then click [OK].

- **[Printer]:**
Select the printer to use.
- **[Print Mode]:**
To print the entire GreatCut-R work screen, select **[Objects with working sheet]**.
If you only need to print the cutting data, select **[Objects]** (you can also select printing by layer).
- **[Output]:**
Select the printing start position and whether or not to use section output.

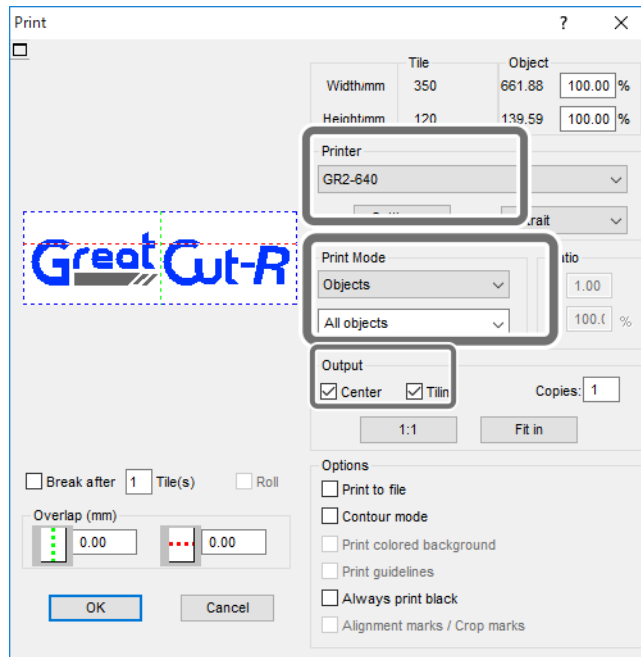

5. Click [OK].

The cutting data is sent to the printer.

RELATED LINKS

- P. 10 "Conditions for Usable Materials"
- P. 11 "Cutting area"

Setting the Output-start Location (Printing and Cutting)

Set the cutting start position (origin). When printing and cutting, the crop marks are read by the AAS sensor equipped on the cutting carriage, and therefore the cutting carriage must be placed near the first crop mark.

MEMO

If the cutting carriage is placed away from the first crop mark, crop marks cannot be detected.

Procedure

1. Check that the material has been properly loaded and set up.
2. Press [◀], [▼], [▲] or [▶] to move the center of the blade to the crop mark origin point.

MEMO

The origin point can be set in either online mode or offline mode.

3. Press [ENTER].

The origin point (cutting start location) is set.

RELATED LINKS

- P. 21 "Loading the Material"
 - P. 128 "Setting the Crop Mark Detection Speed for the AAS Sensor"
-

Performing Cutting

Send a cutting job to the machine to start cutting.

MEMO

If the material comes loose or the machine operates unusually, press [PAUSE/RESUME] to cancel output. Then reload the material, starting over from the beginning.

RELATED LINKS

- P. 33 "Canceling Output"
 - P. 21 "Loading the Material"
-

Sending Adobe Illustrator Cutting Jobs from the Printer Driver

Check that the machine is in online mode and start cutting.



WARNING

Never touch the cutting carriage while output is in progress.

The cutting carriage moves at high speed. Coming into contact with the moving carriage may cause injury.

Procedure

1. Start Adobe Illustrator.
2. Click [File]>[Open] to select cutting data that includes cutting lines.
3. Click [File]>[Print].
The [Print] window appears.
4. Set up the job to be output to the machine.

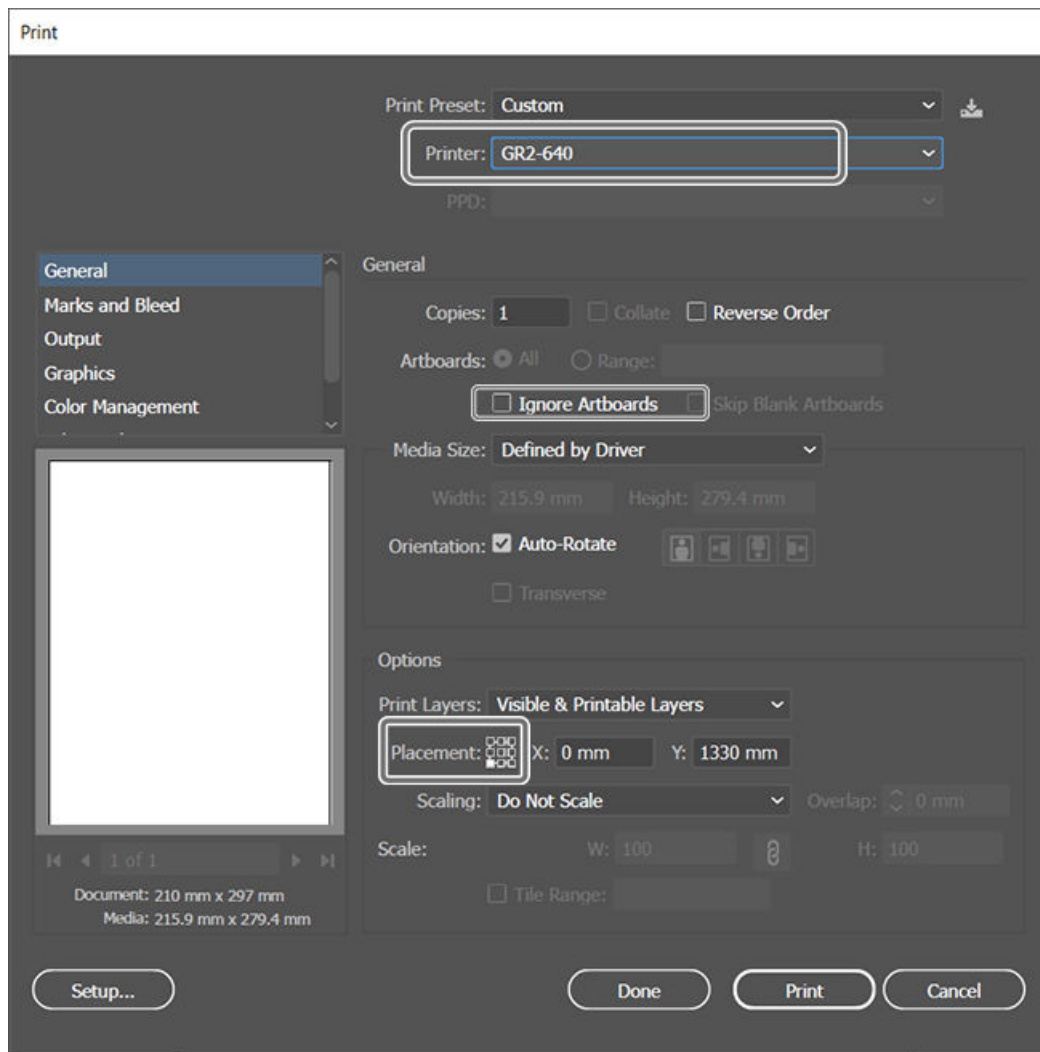

Setting item	Settings	Notes
[Printer]	Select the machine model.	
[Artboards]	Select the [Ignore Artboards] check box.	Clear this check box if the artboard size is suited to the cutting data.
[Placement]	Select the lower-left point.	

5. Press [Setup].
The [Print] window appears.
6. Click [Preferences].
The [Printing Preferences] window appears.

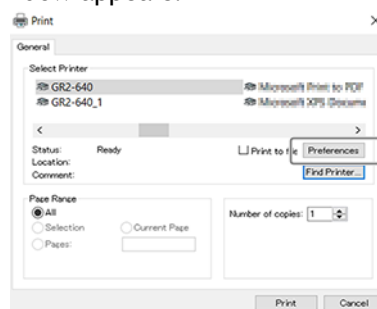

7. Select the [Cutter] tab and change the cutting conditions (①).
If necessary, configure the other cutting settings (②).

If you have saved presets, you can load a preset and apply cutting conditions.

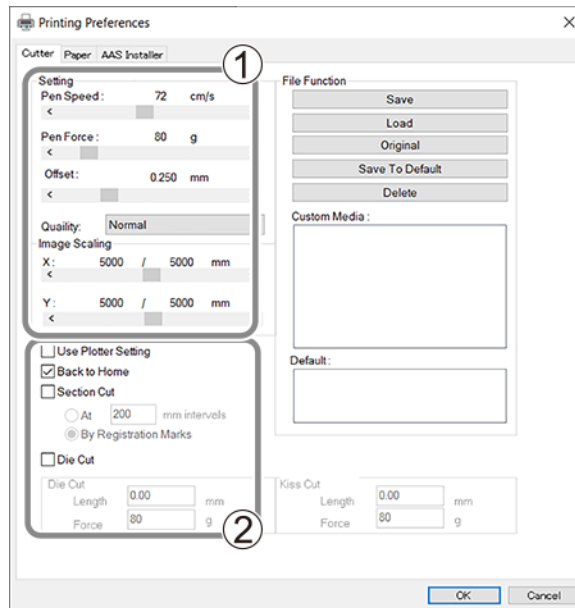

8. Switch to the [Paper] tab and enter the size of the loaded material (X: length/Y: width) under [Paper Size].

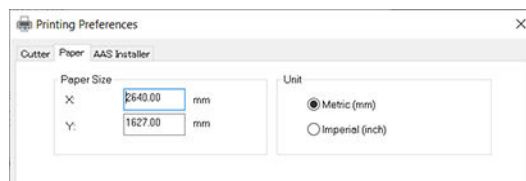

9. Click [OK] to close the [Printing Preferences] window.
10. In the [Print] window, click [Print].
11. In the [Print] window, click [Done].
12. Click [File]>[Print] to open the [Print] window again.
Using the preview, check that the cutting data is displayed at the bottom left.
13. Click [Print].
The cutting job is sent to the machine.

RELATED LINKS

- P. 32 "Remove the Material"
- P. 83 "Setting Up Section Cutting"
- P. 84 "Setting Up Perforated Cutting Using the Printer Driver"
- P. 109 "Setting Overlap Cutting Using the Printer Driver"
- P. 122 "Loading and Applying a Preset"

Sending CorelDRAW Cutting Jobs from the Printer Driver

Check that the machine is in online mode and start cutting.

- ⚠ WARNING** Never touch the cutting carriage while output is in progress.
The cutting carriage moves at high speed. Coming into contact with the moving carriage may cause injury.

Procedure

1. Start CorelDRAW.
2. Click [File]>[Open] to select cutting data that includes cutting lines.
3. Click [File]>[Print].
The [Print] window appears.
4. Select the [General] tab and select this machine model for [Printer].

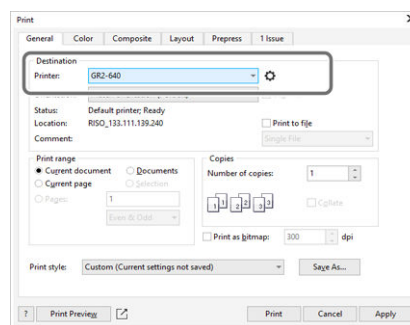

5. Click .
The [Printing Preferences] window appears.
6. Select the [Cutter] tab and change the cutting conditions (①).
If necessary, configure the other cutting settings (②).
If you have saved presets, you can load a preset and apply cutting conditions.

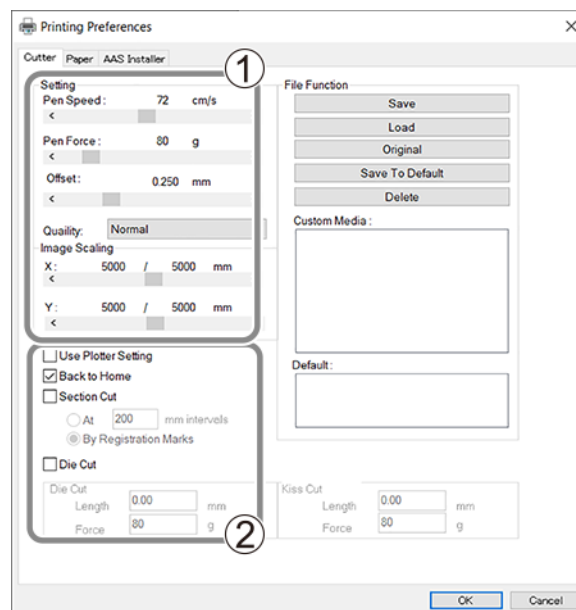

7. Switch to the [Paper] tab and enter the size of the loaded material (X: length/Y: width) under [Paper Size].

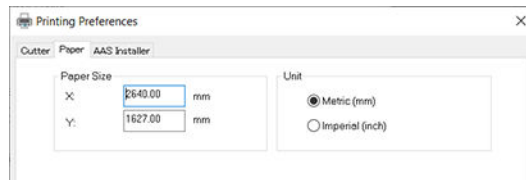

8. Click [OK] to close the [Printing Preferences] window.
9. Switch to the [Color] tab in the [Print] window and select this machine model for [Color conversions].

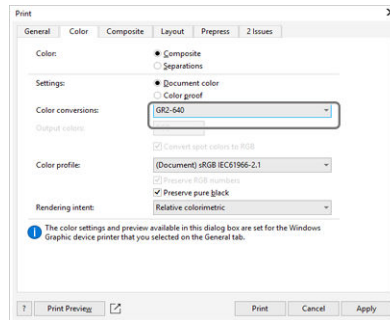

10. Switch to the [Layout] tab and select [Bottom left corner] for [Reposition artwork to].

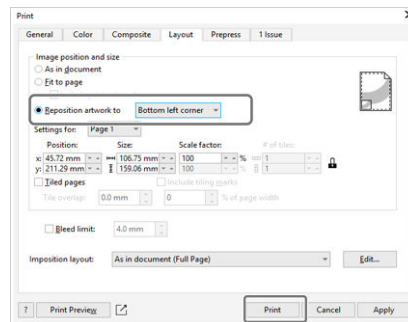

11. Click [Print].
The cutting job is sent to the machine.

RELATED LINKS

- P. 32 "Remove the Material"
- P. 83 "Setting Up Section Cutting"
- P. 84 "Setting Up Perforated Cutting Using the Printer Driver"
- P. 109 "Setting Overlap Cutting Using the Printer Driver"
- P. 122 "Loading and Applying a Preset"

Sending Cutting Jobs from GreatCut-R

Check that the machine is in online mode and start cutting.

⚠ WARNING Never touch the cutting carriage while output is in progress.
The cutting carriage moves at high speed. Coming into contact with the moving carriage may cause injury.

MEMO

If the cutting setting is "Accept setup command" and the cutting job is output from GreatCut-R, the cutting conditions set using GreatCut-R are applied. The printer driver's cutting settings are not applied.

Procedure

1. Start GreatCut-R.
2. Display cutting data, which includes the cutting lines, on the GreatCut-R work screen.
 - GreatCut-R format file:
Select the cutting data from [File]>[Open], and then click [Open].
 - Other files:
Select the cutting data from [File]>[Import], and then click [Open].

MEMO

CorelDRAW format files cannot be imported into GreatCut-R. Open the target cutting data in CorelDRAW and click  on the menu bar.

3. Click [File]>[Output].
The [Output to device] window appears.
4. Set up the job to be output to the machine.

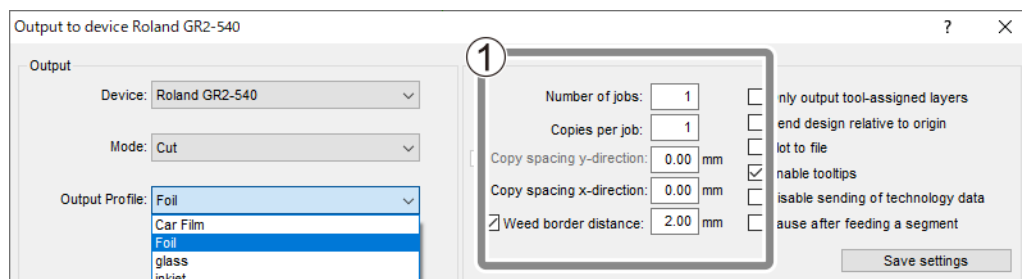

Setting item	Setting details	Notes
[Device]	Set the output device.	Select the machine model.
[Mode]	[Cut with AAS]/[Cut]/[FlexCut]	[Cut with AAS]: For printing and cutting [Cut]: For cutting only [FlexCut]: For perforated cutting
[Output Profile]	[Foil] ^{*1}	
①	Output/save method	Configure these settings according to the cutting job to output.

*1 The first time you perform this action, select the [Foil] saved as default, and after saving some settings as presets, select the profile to use as reference for the material to be cut.

5. Click the parameter values to edit cutting conditions.

If [Mode / Tool] is set to [Default] in the [Layer Settings] window, the values of cutting conditions set here are applied.

MEMO

- [Speed] can be changed in 3 cm/s (1.18 in./s) increments.

Performing Cutting

- Enter 1 in [Step count]. The value entered here is the number of times of cutting in the same location (overlap cutting).

Output to device Roland GR2-640

Output

Device: Roland GR2-640

Mode: Cut

Output Profile: Foil

Manage Profiles ...

Number of jobs: 1

Copies per job: 1

Copy spacing y-direction: 5.00 mm

Copy spacing x-direction: 2.00 mm

Weed border distance: 2.00 mm

Parameter	Value
Pressure [g]	50
Speed [cm/s]	108
Material width [mm]	470.38
Length [mm]	30000.00
Step count	1

6. Click [Read material size] to import the size of the material loaded in the machine.

Accuracy: Normal

Origin: New origin

Objects: All objects

Job will be segmented!

Preview... Output Read material size Test drive Cancel

MEMO

To return the cutting carriage to the set origin after cutting is finished, set [Origin] to [Don't set].

Accuracy: Normal

Origin: Don't set

Test drive

Output Read material size Cancel

7. Click [Output].

The cutting data is sent to the machine and cutting starts.

MEMO

When the cutting data is too large to fit in the material to use, the following window opens. Set the method for dividing the cutting data for cutting on the material, and then click [OK].

Select how to divide the material for the cutting data, and then set inner margins so that no gap is left in the borders (in the X and Y directions) of the divided cutting data.

Segmentation ? X

Optimize material: max. size + last segment smallest

Optimize material: max. size + first segment smallest

Minimize cut through (Smartfeed)

Optimize segments (segments of equal size)

Pre-saved segmentation

Reverse cutting

X Overlap: 0.00 mm

Y Overlap: 0.00 mm

OK Cancel

RELATED LINKS

- P. 86 "Setting Up Perforated Cutting with GreatCut-R"
 - P. 104 "Setting the Weed Border"
 - P. 110 "Setting Up Overlap Cutting with GreatCut-R"
 - P. 124 "Saving Presets with GreatCut-R"
-

Other Cutting

Section Cutting.....	83
Setting Up Section Cutting.....	83
Cutting Perforated Lines	84
Setting Up Perforated Cutting Using the Printer Driver	84
Setting Up Perforated Cutting with GreatCut-R.....	86
Setting Up Perforated Cutting from the Operation Panel.....	89
Cutting Multiple Sets of the Same Cutting Data	90
Duplicating Cutting Data with the AAS Plug-in	90
Duplicating Cutting Data with the GreatCut-R Plug-in	90
Duplicating Cutting Data with GreatCut-R	92
Cutting the Cutting Data Repetitively on Operation Panel	94

Section Cutting

This function cuts material upon scanning the specified distance or by sections specified by crop marks, which stabilizes the cutting quality when cutting long material.

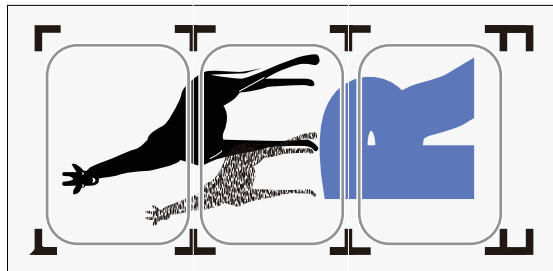
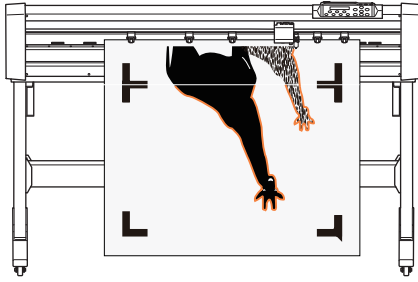

Setting Up Section Cutting

Set section cutting for cutting data with segmental crop marks created with the AAS plug-in.

Procedure

1. Start Adobe Illustrator or CoreIDRAW.
2. Click [File]>[Open] to select cutting data that includes cutting lines.
3. Open the [Printing Preferences] window.
 - P. 49 "Sending Adobe Illustrator Cutting Jobs from the Printer Driver"
 - P. 52 "Sending CoreIDRAW Cutting Jobs from the Printer Driver"
4. Select the [Cutter] tab, and then select the [Section Cut] check box.

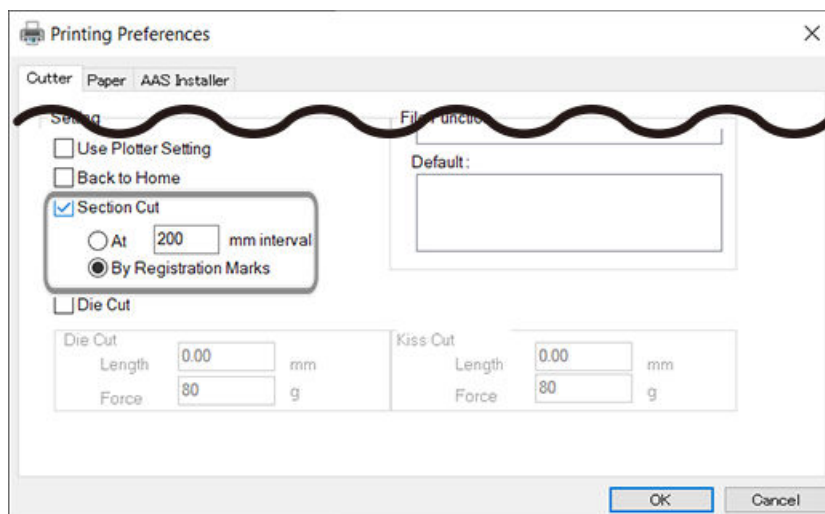

5. Select a section cutting method.
 - Cutting at specified interval: Enter the cutting distance in the XY direction from the cutting start position (origin).
 - Cutting by crop mark position: Select [By Registration marks] (effective when segmental crop marks are set up).
6. Click [OK].

Cutting Perforated Lines

Perforated cutting is set up by combining Die Cut (②), which cuts through to the carrier paper, and Kiss Cut (①), which only cuts through the material, leaving the carrier paper intact. Perforated cutting can be used with materials with no carrier paper, such as coated paper.

IMPORTANT

Leave some parts of the carrier paper uncut even when you want to cut through parts of the material. Cutting through to the carrier paper in all parts can cause a material feeding failure or paper jam.

MEMO

The blade force depends on the type of material or paper used. Adjust the blade force for both Die Cut and Kiss Cut according to the material used by running a cutting test to check the cutting quality for the material.

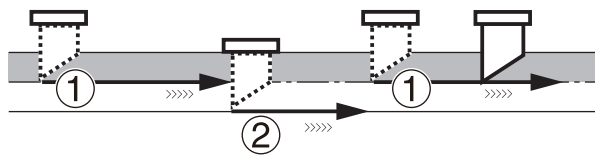
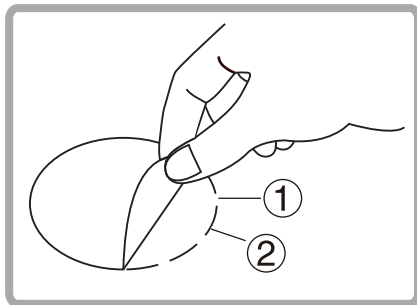

Setting Up Perforated Cutting Using the Printer Driver

Save the cutting lines in the cutting data as perforated cutting lines and set up perforated cutting using the printer driver.

Procedure

1. Start Adobe Illustrator or CoreIDRAW.
2. Click [File]>[Open] to open the file.
3. Set the cutting line to be perforated to green (R: 0 G: 255 B: 0) with a width of 0.001 mm (0.04 mil).
4. Open the [Printing Preferences] window.
 - P. 49 "Sending Adobe Illustrator Cutting Jobs from the Printer Driver"
 - P. 52 "Sending CoreIDRAW Cutting Jobs from the Printer Driver"
5. Select the [Cutter] tab, and then select the [Die Cut] check box.

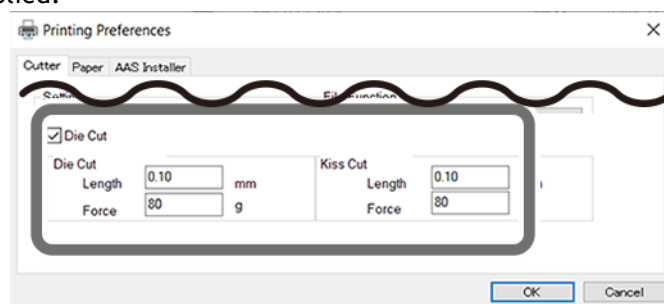

The blade forces and cutting lengths for [Die Cut] and [Kiss Cut] set with the driver are applied.

If the [Die Cut] check box is cleared, the "Die/Kiss Cut" cutting conditions set with the operation panel are applied.

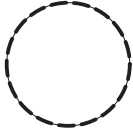

6. Set the cutting lengths and blade forces for [Die Cut] and [Kiss Cut], respectively.

The ranges of [Die Cut] length and [Kiss Cut] length are 0 to 2000 mm (0 to 78.74 in.) and 0 to 100 mm (0 to 3.93 in.), respectively.

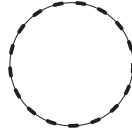
Die Cut length > Kiss Cut length	Die Cut length = Kiss Cut length	Die Cut length < Kiss Cut length
		

7. Click [OK].

Setting Up Perforated Cutting with GreatCut-R

Set the cutting line output in the [Layer Settings] window of GreatCut-R, and set the conditions for perforated cutting from the operation panel.

Procedure

1. Start GreatCut-R.
2. Display cutting data, which includes the cutting lines, on the GreatCut-R work screen.
 - GreatCut-R format file:
Select the cutting data from [File]>[Open], and then click [Open].
 - Other files:
Select the cutting data from [File]>[Import], and then click [Open].

MEMO

CorelDRAW format files cannot be imported into GreatCut-R. Open the target cutting data in CorelDRAW and click  on the menu bar.

3. Right-click on any layer in the Layer window.

The [Layer Settings] window appears. If the Layer window is not displayed on the work screen, turn on [Window]>[Layer].

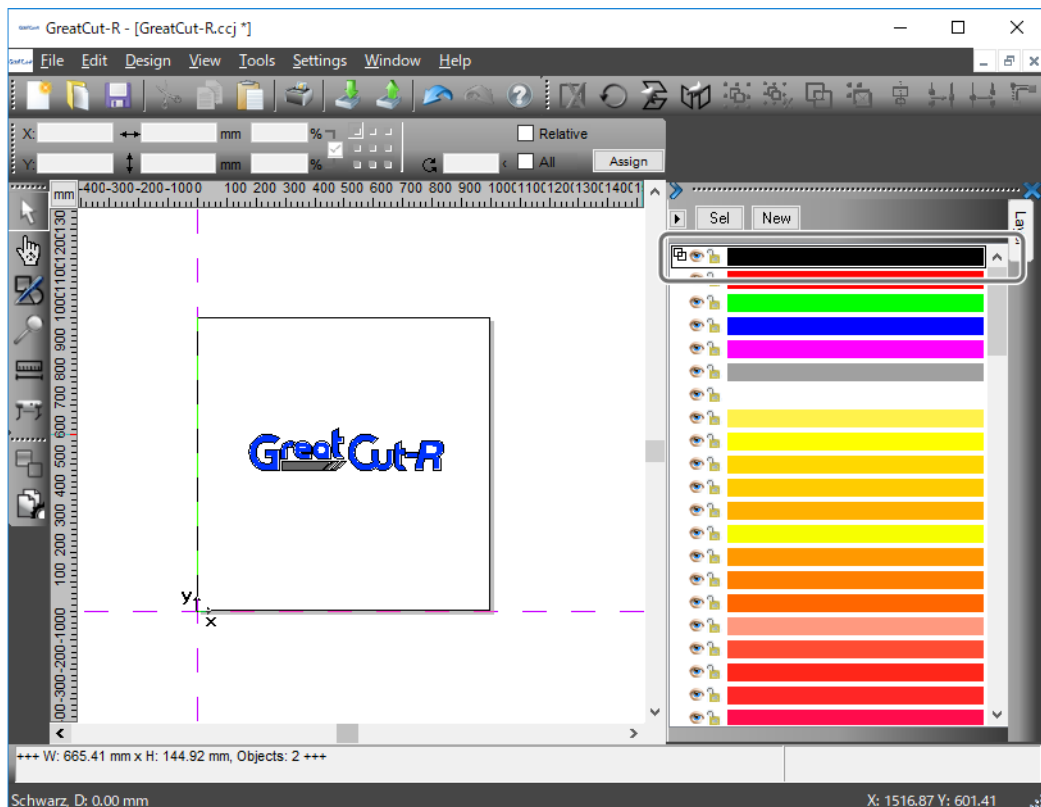

4. Click [Output].

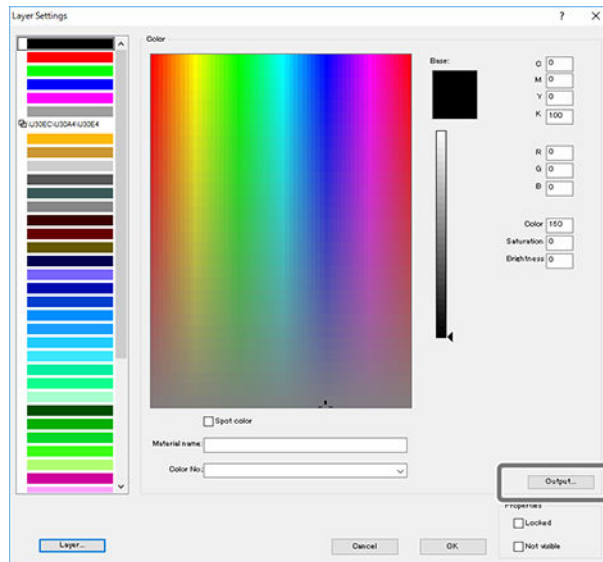

5. Select a color in the color palette, and then select [FlexCut] from the [Mode / Tool] list.
Set green to perforated cutting to differentiate this color from the layer colors used by other cutting lines.

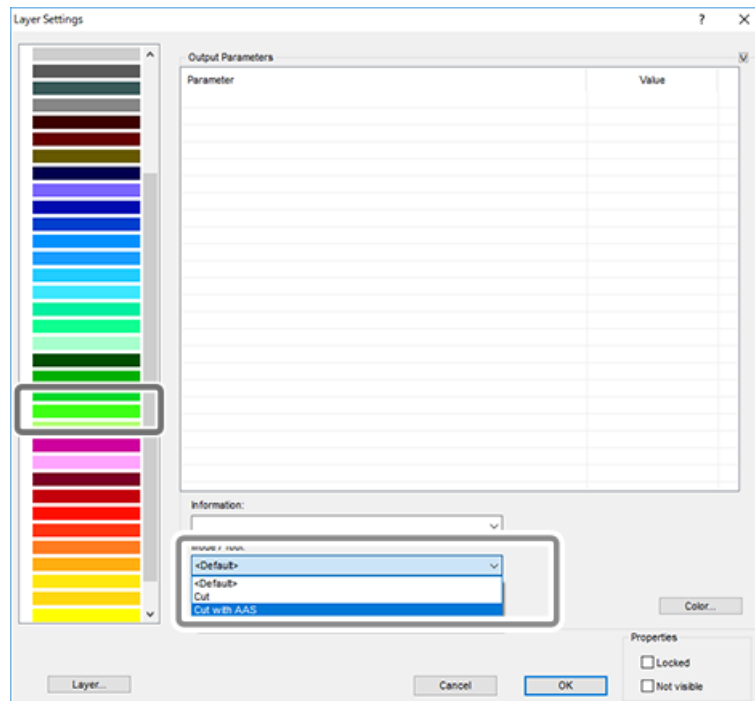

When the following screen appears, click [Yes].

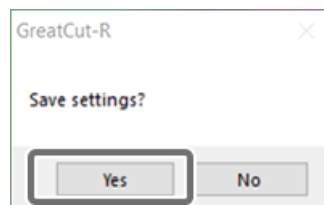

6. Click the parameter value to set the cutting conditions for the cutting data.
The blade force is not changed here because the [Die/Kiss Cut] value set from the operation panel is applied.
7. Click [OK].

The green layer is set as perforated cutting.

- 8.** Select the cutting line to set to perforated cutting, and then double-click green (the layer set to [FlexCut]) in the Layer window.

The selected cutting line changes to green.

- 9.** Set perforated cutting from the operation panel.

➤ P. 89 "Setting Up Perforated Cutting from the Operation Panel"

RELATED LINKS

- P. 99 "Configuring the Cutting Conditions Based on the Color of Cutting Lines"
-

Setting Up Perforated Cutting from the Operation Panel

You can set up perforated cutting on the operation panel.

Procedure

1. Press [MISC].

If material is loaded, press [ON/OFF LINE] to switch to offline mode.

2. Press [▶] several times to display the screen shown below.

The current setting is displayed.

```
Die/Kiss Cut : OFF ▲
Select: ◀ OK:ENTER ▼
```

3. If "Die/Kiss Cut" is "OFF", press [▲] or [▼] to switch "Die/Kiss Cut" to "ON".

4. Press [ENTER].

5. Set the cutting lengths for "Die Cut" and "Kiss Cut".

```
Die/Kiss Cut: ▲▼◀▶
Length: XX / XX mm
```

(1) Press [◀] to select "Die Cut". Press [▶] to select "Kiss Cut".

(2) Press [▲] or [▼] to change the value.

6. Press [ENTER].

7. Set the blade forces for "Die Cut" and "Kiss Cut" on the following screen.

```
Die/Kiss Cut: ▲▼◀▶
Force: XXX g XXX g
```

(1) Press [◀] to select "Die Cut". Press [▶] to select "Kiss Cut".

(2) Press [▲] or [▼] to change the value.

8. Press [ENTER].

9. Press [ON/OFF LINE] to go back to the original screen.

MEMO

Default setting: "OFF"

Cutting length setting range (Die Cut/Kiss Cut): 0.1 to 100 mm/0.1 to 100 mm (changeable in 0.1 mm increments)

Blade force setting range (Die Cut/Kiss Cut): 5 to 600 gf/5 to 600 gf (changeable in 5 gf increments)

Cutting Multiple Sets of the Same Cutting Data

Create multiple sets of cutting data by duplicating cutting data for printing and cutting or for cutting only.

Duplicating Cutting Data with the AAS Plug-in

Use the AAS plug-in to create duplicate data for printing and cutting and send cutting jobs to the printer driver.

Procedure

1. Start Adobe Illustrator or CorelDRAW.
2. Click [File]>[Open] to select cutting data that includes cutting lines.
3. Set multiple copies of crop marks in the cutting data.
 - P. 64 "Setting Crop Marks with the AAS Plug-in (Adobe Illustrator)"
 - P. 66 "Setting Crop Marks with the AAS Plug-in (CorelDRAW)"
4. Print all of the duplicated data to the material using your printer.
 - P. 71 "Printing Cutting Data on Material"
5. Load the material in the machine.
 - P. 21 "Loading the Material"
6. Set the cutting start position (origin).
 - P. 48 "Setting the Output-start Location"
 - P. 73 "Setting the Output-start Location (Printing and Cutting)"
7. Send the cutting job to the machine.
 - P. 49 "Sending Adobe Illustrator Cutting Jobs from the Printer Driver"
 - P. 52 "Sending CorelDRAW Cutting Jobs from the Printer Driver"

Duplicating Cutting Data with the GreatCut-R Plug-in

Create printing data by duplicating the cutting data that includes cutting lines in the direction specified using GreatCut-R, and set up the cutting.

Procedure

1. Start Adobe Illustrator or CorelDRAW.
2. Click [File]>[Open] to select cutting data that includes cutting lines.
3. For printing and cutting, duplicate cutting data with crop marks set up and print it on the material.
 - (1) Set the four-point crop marks.
 - P. 68 "Setting Crop Marks with the GreatCut-R Plug-in (Adobe Illustrator/CorelDRAW)"
 - (2) Select cutting data that includes crop marks.
 - (3) Open the [Multi-Copy] window and enter the number of duplications and the distance between data sets in the X and Y directions, respectively.
 - Adobe Illustrator: Click [File]>[GreatCut-R]>[Multi-Copy].
 - CorelDRAW: Click  displayed on the menu bar.

If you want to duplicate the cutting data using the distance starting from the origin in the original data (bottom left), select [Distance] from the pull-down list.

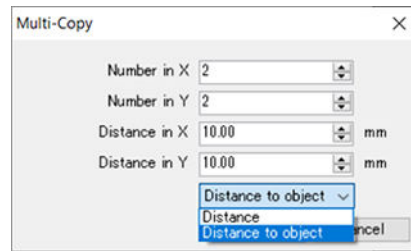

(4) Click [OK].

The cutting data and crop marks for the entered numbers specified for each direction are duplicated.

(5) Print all of the duplicated data to the material using your printer.

➤ P. 71 "Printing Cutting Data on Material"

(6) Delete the duplicated cutting data and crop marks.

(7) Select the cutting data that includes cutting lines and crop marks, and send the cutting data to GreatCut-R.

- Adobe Illustrator: Click [File]>[GreatCut-R]>[Cut].
- CorelDRAW: On the toolbar, click  .

4. Load the material in the machine.

➤ P. 21 "Loading the Material"

5. Click [File]>[Cut] on GreatCut-R.

The [Output to device] window appears.

6. Enter the number of duplications in [Copies per job], and then enter values to specify the space between cutting data sets.

For printing and cutting, enter the same values as used for the duplicate data created on the material.

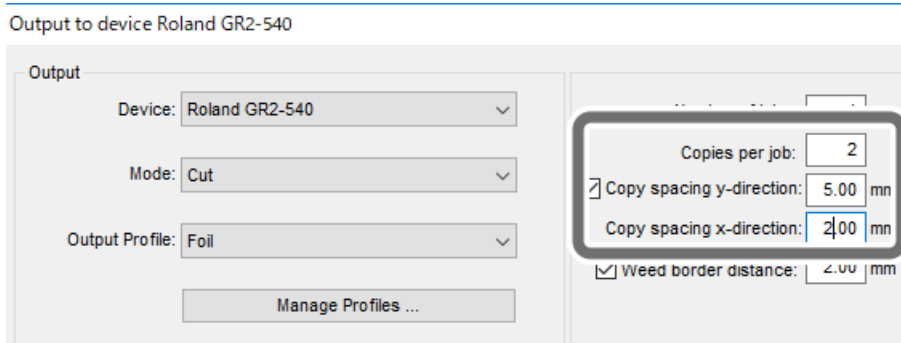

7. Select an option for [Device], [Mode], and [Output Profile] from their pull-down lists and click [Output].

Setting item	Setting details	Notes
[Device]	Set the output device.	Select the machine model.
[Mode]	[Cut with AAS]/[Cut]/ [FlexCut]	[Cut with AAS]: For printing and cutting [Cut]: For cutting only [FlexCut]: For perforated cutting
[Output Profile]	[Foil]*1	Click the parameter values to edit cutting conditions.

*1 The first time you perform this action, select the [Foil] saved as default, and after saving some settings as pre-sets, select the profile to use as reference for the material to be cut.

Duplicating Cutting Data with GreatCut-R

Duplicate cutting data including cutting lines in the direction specified using GreatCut-R.

Procedure

1. Start GreatCut-R.
2. Display cutting data, which includes the cutting lines, on the GreatCut-R work screen.
 - GreatCut-R format file:
Select the cutting data from [File]>[Open], and then click [Open].
 - Other files:
Select the cutting data from [File]>[Import], and then click [Open].

MEMO

CorelDRAW format files cannot be imported into GreatCut-R. Open the target cutting data in CorelDRAW and click  on the menu bar.

3. For printing and cutting, duplicate cutting data with crop marks set up and print it on the material.
 - (1) Set the four-point crop marks.
 - P. 69 "Setting Crop Marks with GreatCut-R"
 - (2) Select cutting data that includes crop marks.
 - (3) Click  on the menu bar.
Enter the number of duplications and the distance between data sets in the X and Y directions, respectively.

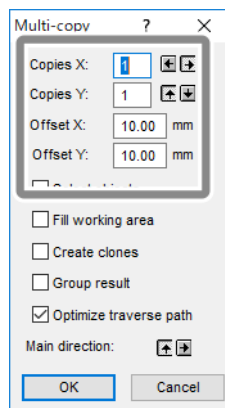

- (4) Click [OK].
The cutting data and crop marks for the entered numbers specified for each direction are duplicated.
 - (5) Print all of the duplicated data to the material using your printer.
 - P. 71 "Printing Cutting Data on Material"
 - (6) Load the material in the machine.
 - P. 21 "Loading the Material"
 - (7) Delete the duplicated cutting data and crop marks.
 - (8) Select the cutting data that includes cutting lines and crop marks set in the cutting data.
4. Click [File]>[Cut].
The [Output to device] window appears.
 5. Set "Copies per job" and enter the [Copy spacing x-direction] and [Copy spacing y-direction] values.

For printing and cutting, enter the same values as used for the duplicate data created on the material.

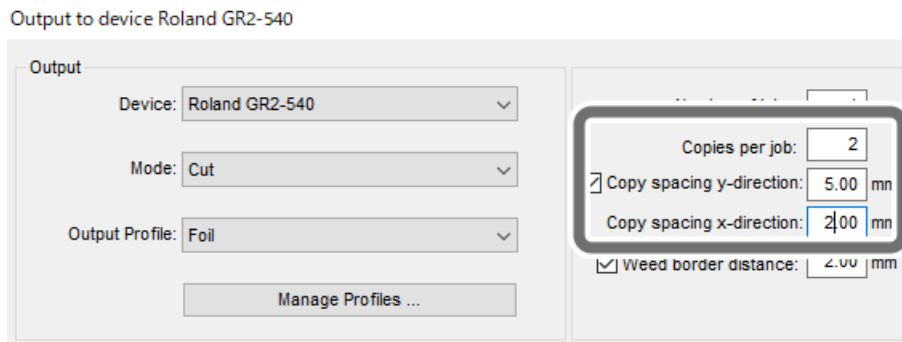

6. Select an option for [Device], [Mode], and [Output Profile] from their pull-down lists and click [Output].

Setting item	Setting details	Notes
[Device]	Select the machine model.	
[Mode]	[Cut with AAS]/[Cut]/ [FlexCut]	[Cut with AAS]: For printing and cutting [Cut]: For cutting only [FlexCut]: For perforated cutting
[Output Profile]	[Foil] ^{*1}	Click the parameter values to edit cutting conditions.

*1 The first time you perform this action, select the [Foil] saved as default, and after saving some settings as pre-sets, select the profile to use as reference for the material to be cut.

Cutting the Cutting Data Repetitively on Operation Panel

You can repetitively cut a job sent to the cutting machine.

Printing and Cutting (Specified Count)

Use the operation panel to enter the distance between crop marks set in the cutting data to repeat cutting a specified number of times.

MEMO

- When, for example, setting multiple copies of crop marks, arrange the cutting data with the same spacing and print this data on the material in advance.
- To send jobs from the printer driver, open the [Printing Preferences] window, and then select the [Back to Home] check box.
- To send jobs from GreatCut-R, open the [Output to device] window, and then set [Origin] to [Don't set].

Procedure

1. Press [MISC].

If material is loaded, press [ON/OFF LINE] to switch to offline mode.

2. Press [▶] several times to display the screen shown below.

```
AAS Copy:
Select: ◀ OK:ENTER
```

3. Press [ENTER].

The current value is displayed on the screen.

4. If this function is set to "Disabled", press [▲] or [▼] to select "Enabled".

5. Press [ENTER].

6. Press [▲] or [▼] to enter the distance between the crop marks.

```
Distance: 175mm
Change: ◀▶ OK:ENTER
```

7. Press [ENTER] to confirm your entry.

8. Press [▲] or [▼] to enter the number of repetitions.

```
Times      1
Change: ◀▶ OK:ENTER
```

9. Press [ENTER] to confirm your entry.

10. Press [ON/OFF LINE] to go back to the original screen.

11. Load the material in the machine.

➤ P. 21 "Loading the Material"

12. Set the cutting start position (origin).

➤ P. 73 "Setting the Output-start Location (Printing and Cutting)"

13. Send the cutting job to the machine.

➤ P. 49 "Performing Cutting"

RELATED LINKS

- P. 109 "Setting Overlap Cutting Using the Printer Driver"

- P. 54 "Sending Cutting Jobs from GreatCut-R"

Printing and Cutting

Load in the device the same cutting data printed on multiple pieces of material, and then use the operation panel to repetitively cut a preceding AAS job recorded in the machine.

MEMO

Turning the power off will disable the record of the preceding AAS job sent to the machine.

Procedure

1. Load the material and measure its size.
 - P. 21 "Loading the Material"
2. Press [ON/OFF LINE] to switch to offline mode.
3. Press [CUT TEST].
4. Press [▶] several times to display the screen shown below.

```
Repeat AAS Job  
Select: ◀ OK: ENTER
```

5. Press [ENTER].

The screen shown below appears. Cutting starts after the crop marks are read.

```
AAS Detecting  
OK: ENTER
```

RELATED LINKS

- P. 54 "Sending Cutting Jobs from GreatCut-R"
 - P. 109 "Setting Overlap Cutting Using the Printer Driver"
-

Cut Only

You can repeatedly cut the preceding cutting job sent to the cutting machine for the specified number of times while maintaining the cutting data's relative distance from the origin.

MEMO

- To send jobs from the printer driver, open the [Printing Preferences] window, and then select the [Back to Home] check box.
- To send jobs from GreatCut-R, open the [Output to device] window, and then set [Origin] to [Don't set].

Procedure

1. Load the material and measure its size.
 🔍 P. 21 "Loading the Material"
2. Press [ON/OFF LINE] to switch to offline mode.
3. Press [CUT TEST].
4. Press [▶] several times to display the screen shown below.

```
Redo Jobs in Memory
Select:◀ OK:ENTER
```

5. Press [ENTER].
The current value is displayed on the screen.

```
Recut # 1▲
Select:◀ OK:ENTER▼
```

6. Press [▶] to select "Copy".

```
Copy # 1▲
Select:◀ OK:ENTER▼
```

7. Press [▲] or [▼] to select the number of repetitions.
8. Press [ENTER].
Cutting starts for the specified number of times.
9. When the cutting is finished, press [ON/OFF LINE] to go back to the original screen.

RELATED LINKS

- P. 54 "Sending Cutting Jobs from GreatCut-R"
 - P. 109 "Setting Overlap Cutting Using the Printer Driver"
-

Optimizing Quality and Efficiency

Using GreatCut-R

Setting Up Cutting by Layer.....	99
Configuring the Cutting Conditions Based on the Color of Cutting Lines.....	99
Manually Setting the Cutting Order	101
Simulating the Cutting Order.....	102
Setting the Weed Border	104
Using the Material with Minimal Waste	106
Aligning Cutting Data by Conditions (Nesting).....	106

Setting Up Cutting by Layer

Cutting data can be grouped into layers by color or type of cutting line, and you can set parameters as cutting conditions and the cutting mode for each layer. The cutting output order can also be changed manually or automatically.

Configuring the Cutting Conditions Based on the Color of Cutting Lines

You can set cutting conditions for each layer. Because objects drawn using vector lines are also grouped into layers, check whether a layer includes cutting lines while setting the cutting conditions.

Procedure

1. Start GreatCut-R.
2. Display cutting data, which includes the cutting lines, on the GreatCut-R work screen.
 - GreatCut-R format file:
Select the cutting data from [File]>[Open], and then click [Open].
 - Other files:
Select the cutting data from [File]>[Import], and then click [Open].

MEMO

CorelDRAW format files cannot be imported into GreatCut-R. Open the target cutting data in CorelDRAW and click  on the menu bar.

3. Right-click on any layer in the Layer window.
The [Layer Settings] window appears. If the Layer window is not displayed, turn on [Window]>[Layer].
4. Click the layer with the cutting lines used in the cutting data and configure the layer's output settings.
Clicking [Output] or [Color] switches the display of the [Layer Settings] window.

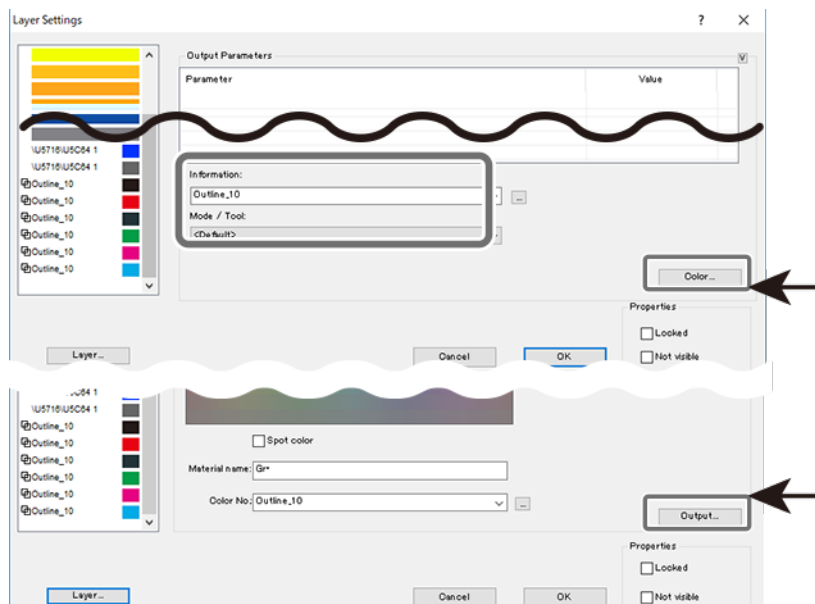

Setting item	Settings	Notes
[Information]		Enter the layer name by combining the cutting type, color number, etc.*1

Setting Up Cutting by Layer

Setting item	Settings	Notes
[Mode / Tool] ^{*2}	[Defalut] [Cut] [Cut with AAS] [FlexCut]	[Defalut]: The parameter values set in the [Output to device] window are applied. ^{*3} [Cut]: Set to cutting only [Cut with AAS]: Set to printing and cutting [FlexCut]: Set to perforated cutting

*1 This synchronizes with [Color No.] in the dialog when [Color] is clicked.

*2 When Cutting mode is selected, settable parameters and [Material] are displayed.

*3 When this mode is selected, the order of output layers cannot be set manually.

5. Set [Material] (①) and parameter (②).

If there is no option to select for [Material], click [...] to add materials. Click the parameter value to edit it.

MEMO

- Enter 1 in [Step count]. Entering a value other than 1 sets up overlap cutting.
- If [Defalut] is selected from the [Mode / Tool] list, the parameters set in the [Output to device] window are applied, so parameters are not set here.

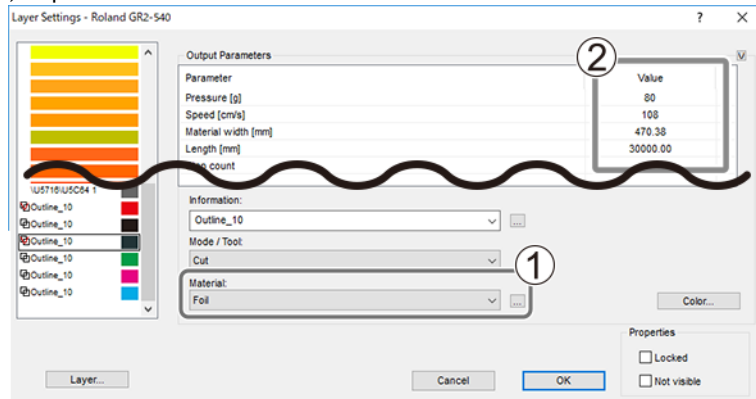

Layers with their output settings configured are marked with a red check mark next to them.

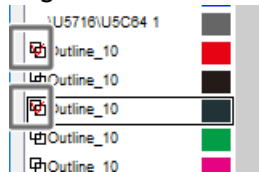

6. Click [OK] to close the [Layer Settings] window.

Manually Setting the Cutting Order

Manually set the layer output order.

MEMO

If [Default] is selected from the [Mode / Tool] list in the layer cutting condition settings, the cutting order cannot be set.

Procedure

1. Start GreatCut-R.
2. Display cutting data, which includes the cutting lines, on the GreatCut-R work screen.
 - GreatCut-R format file:
Select the cutting data from [File]>[Open], and then click [Open].
 - Other files:
Select the cutting data from [File]>[Import], and then click [Open].

MEMO

CorelDRAW format files cannot be imported into GreatCut-R. Open the target cutting data in CorelDRAW and click  on the menu bar.

3. Click [Settings]>[Color Palette]>[Layer Order].
The [Layer Order] window appears.
4. Select the layer you want to change the order of and click a location under [Move Layer] (1).

MEMO

Layers are cut in the order displayed in the [Layer Order] window (top to bottom). Layers must be in rational order based on cutting methods. Any layer with drawing only should be placed before a layer that includes cutting edges.

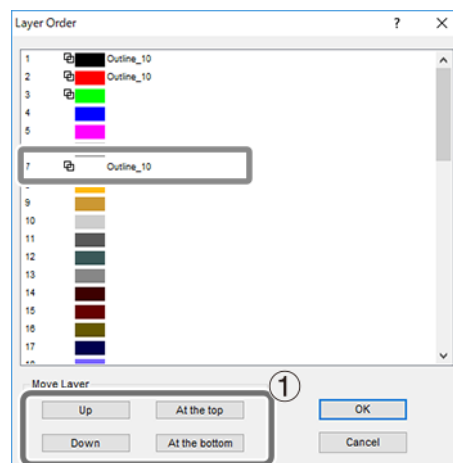

5. Click [OK].
The layer order is saved.

Simulating the Cutting Order

This procedure simulates the order of cutting output for all layers or by layer prior to actual cutting, and automatically sorts the output order in the defined direction.

Procedure

1. Start GreatCut-R.
2. Display cutting data, which includes the cutting lines, on the GreatCut-R work screen.
 - GreatCut-R format file:
Select the cutting data from [File]>[Open], and then click [Open].
 - Other files:
Select the cutting data from [File]>[Import], and then click [Open].

MEMO

CorelDRAW format files cannot be imported into GreatCut-R. Open the target cutting data in CorelDRAW and click  on the menu bar.

3. Click [Design]>[Sort with Simulation].
The [Sort with Simulation] window appears.
4. Select simulation method (①) for layer (②).
Simulation method cannot be selected if there is only one layer (color) in the cutting data.
 - To run a simulation of the selected layer, select [Selected layer].
 - To run a simulation of all layers, select [All layers].

Moving the square frame that indicates the currently selected layer to a layer that is not the topmost layer after selecting [All layers] will set up a simulation for only the layers under the layer with the square frame.

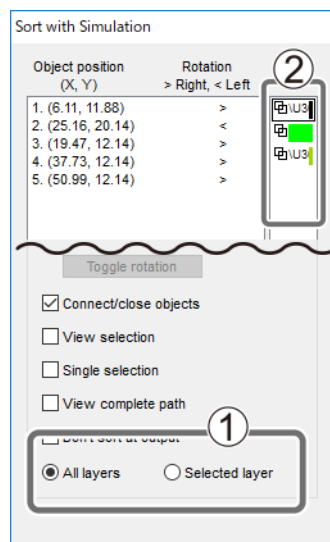

5. Adjust the simulation speed using the slider and click .
The simulation starts. Check the cutting order and cutter path.
6. To change the order of cutting output, select [Sorting method] and click [Sort].
To sort by [By main direction], select the output direction that you want to change to by scrolling down the options in [Main Direction]. The current output direction is displayed on the left side.

The order of cutting output is sorted by the selected method. Click  to check the order of cutting output after change.

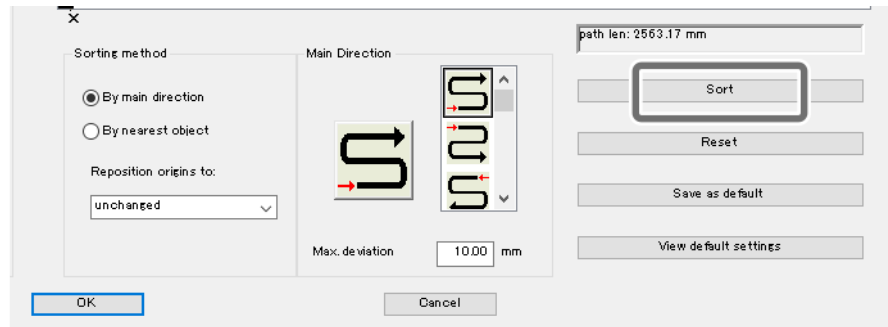

7. Click [OK].

When sorting is changed, the settings are saved.

Setting the Weed Border

A weed border is set up when outputting a large cutting job that has a length or width of several meters or when outputting jobs with multiple sets of cutting data. This makes the output cutting data easier to handle. A rectangular weed border is created around the cutting data during the cutting process, making it easier to separate the cutting data. Additionally, setting weeding lines to the weed border can help with the removal of unnecessary portions of the material. Use the weed border for complex designs and large jobs.

Procedure

1. Start GreatCut-R.
2. Display cutting data, which includes the cutting lines, on the GreatCut-R work screen.
 - GreatCut-R format file:
Select the cutting data from [File]>[Open], and then click [Open].
 - Other files:
Select the cutting data from [File]>[Import], and then click [Open].

MEMO

CorelDRAW format files cannot be imported into GreatCut-R. Open the target cutting data in CorelDRAW and click  on the menu bar.

3. Click [File]>[Cutting].
The [Output to device] window appears.
4. Select the [Weed border distance] check box, and then enter the distance from the cutting data.

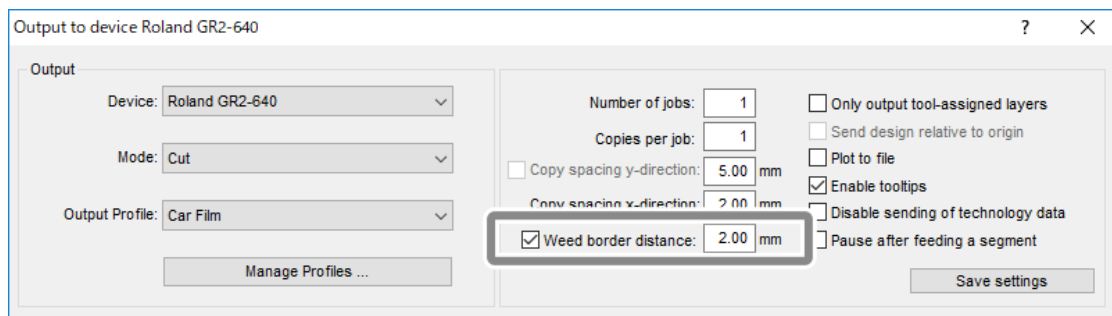

MEMO

Click [Preview] to check that a weed border (blue dotted line) has been added to the cutting data.

5. You can insert a weeding line by either of the following methods.

A weeding line is added as a red dotted line inside the weed border.

- Place weeding lines evenly inside the weed border:
In the [Output at ***] window, click [Options]>[Horizontal Weeding Lines] and [Vertical Weeding Lines]. (With every click, a weeding line that evenly divides the weed border is inserted vertically or horizontally.)
- Place weeding lines in desired locations:
When the cursor is placed on the weed border, the shape of the cursor turns into a double-headed arrow. In this state, drag the mouse to the target position.
When the cursor is placed on the created weeding line, the shape of the cursor turns into a double-headed arrow. In this state, drag the weeding line to move it to the target position.

MEMO

Weeding lines can be set up when [Weed border distance] is selected in the [Output to device] window.

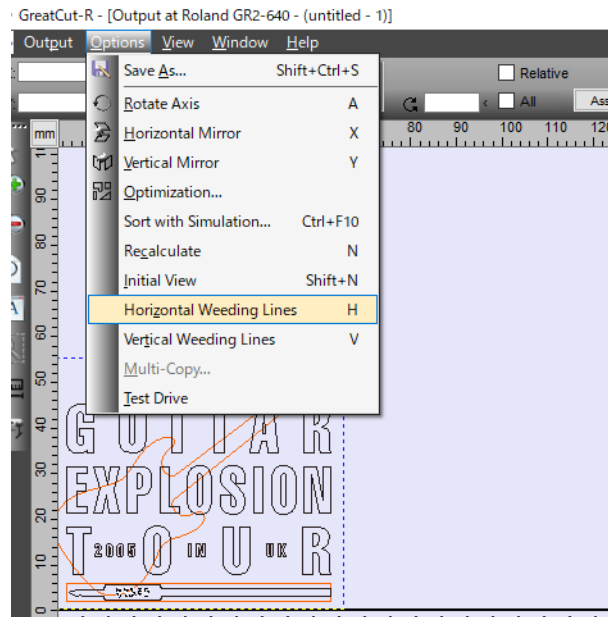

6. In the [Output at ***] window, press [Output] to send the job to the cutting machine.

Using the Material with Minimal Waste

When there are multiple sets of cutting data in a single job, set the cutting conditions so that the cutting data is arranged with a minimum amount of unused space on the material.

Aligning Cutting Data by Conditions (Nesting)

You can sort cutting data objects on the work screen or output preview.

Procedure

1. Start GreatCut-R.
2. Display cutting data, which includes the cutting lines, on the GreatCut-R work screen.
 - GreatCut-R format file:
Select the cutting data from [File]>[Open], and then click [Open].
 - Other files:
Select the cutting data from [File]>[Import], and then click [Open].

MEMO

CorelDRAW format files cannot be imported into GreatCut-R. Open the target cutting data in CorelDRAW and click  on the menu bar.

3. Perform one of the following operations to open the [Box nesting] window.
 - On the toolbar on the work screen, click .
 - Click [Tools]>[Box nesting].
 - Click [File]>[Cut] to open the [Output to device] window, and then click [Preview]>[Options]>[Optimization].

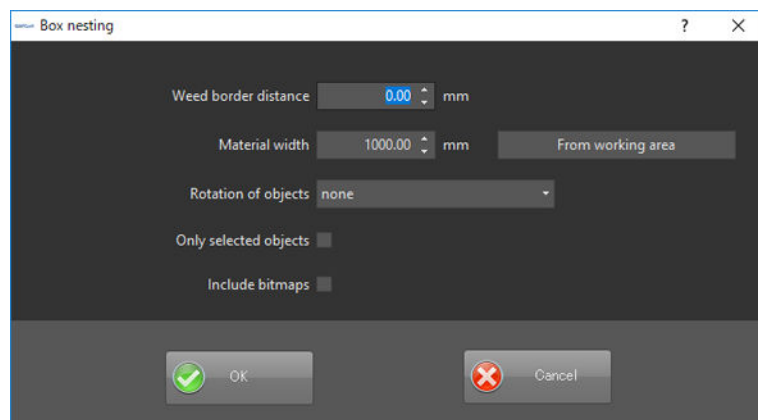

4. Set up cutting job sorting.

Setting item	Setting details
[Weed border distance]	When setting up weed borders in the cutting data, enter the weed border distance.
[Material width]	Enter the sorting target range. To set the range to the material size recorded in the machine, select [From working area].
[Rotation of objects]	<ul style="list-style-type: none"> • To sort without rotating, select [none]. • To rotate objects so that the shorter side comes to the bottom, select [to the shortest side]. • To save the most space by rotating all objects, select [as required].
[Only selected objects]	Select this option when sorting by selected layer (color).
[Include bitmaps]	Select this option when including bitmaps (including grouped bitmaps) in the nesting.

5. Click [OK].

Optimizing the Output Quality

Dealing with Material Thickness/Hardness (Softness)	109
Overlap Cutting.....	109
Adjusting the Cutting-in Amount	112
Cutting the Corners Longer to Make It Easy to Detach Cutting Data (Over Cut).....	113
Cutting Small Text and Complex Graphics Cleanly (Tangential).....	114
Smoothly Cutting Arcs and Other Curves (Smoothing)	115
Preventing and Correcting Misaligned Cutting	116
Keeping Material in Place and Stabilizing Cutting Accuracy.....	116
Correcting Distance during Cutting Based on the Thickness of Material	117

Dealing with Material Thickness/Hardness (Softness)

Overlap Cutting

This function allows you to cut thick material that cannot be cut in one go by returning the machine to the original position after the first run to repeat the same cutting process.

Setting Overlap Cutting Using the Printer Driver

Procedure

1. Start Adobe Illustrator or CorelDRAW.
2. Open the [Printing Preferences] window.
 - P. 49 "Sending Adobe Illustrator Cutting Jobs from the Printer Driver"
 - P. 52 "Sending CorelDRAW Cutting Jobs from the Printer Driver"
3. Select the [Cutter] tab, and then select the [Back to Home] check box.

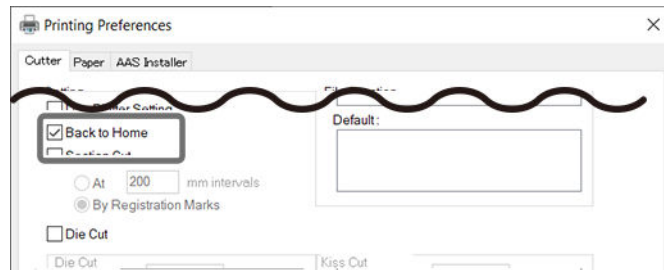

MEMO

When you have finished configuring the settings, send a number of cutting jobs from the printer driver to match the number of overlap cutting processes.

RELATED LINKS

- P. 49 "Sending Adobe Illustrator Cutting Jobs from the Printer Driver"
- P. 52 "Sending CorelDRAW Cutting Jobs from the Printer Driver"

Setting Up Overlap Cutting with GreatCut-R

You can set up to five overlap cutting processes in which cutting is repeated in the same position.

Procedure

1. Start GreatCut-R.
2. Display cutting data, which includes the cutting lines, on the GreatCut-R work screen.
 - GreatCut-R format file:
Select the cutting data from [File]>[Open], and then click [Open].
 - Other files:
Select the cutting data from [File]>[Import], and then click [Open].

MEMO

CorelDRAW format files cannot be imported into GreatCut-R. Open the target cutting data in CorelDRAW and click  on the menu bar.

3. Click [File]>[Cut].
The [Output to device] window appears.
4. Click the [Step count] value under [Parameter] and select the number of times to cut.

Output to device Roland GR2-640

Parameter	Value
Device: Roland GR2-640	
Mode: Cut	
Output Profile: Foil	
Number of jobs:	1
Copies per job:	1
<input type="checkbox"/> Copy spacing y-direction:	5.00 mm
Copy spacing x-direction:	2.00 mm
<input checked="" type="checkbox"/> Weed border distance:	2.00 mm
Pressure [g]	80
Speed [cm/s]	108
Material width [mm]	470.38
Length [mm]	30000.00
Step count	1

Setting Up Overlap Cutting on the Operation Panel

Using the operation panel, you can repetitively cut a preceding cutting job sent to the cutting machine.

MEMO

- To send jobs from the printer driver, open the [Printing Preferences] window, and then select the [Back to Home] check box.
- To send jobs from GreatCut-R, open the [Output to device] window, and then set [Origin] to [Don't set].

Procedure

1. Load the material and measure its size.
 Ⓧ P. 21 "Loading the Material"
2. Press [ON/OFF LINE] to switch to offline mode.
3. Press [CUT TEST].
4. Press [▶] several times to display the screen shown below.

```
Redo Jobs in Memory
Select: ◀ OK:ENTER
```

5. Press [ENTER].
 The current value is displayed on the screen.

```
Recut # 1 ▲
Select: ◀ OK:ENTER ▼
```

6. Press [▶] to select [Recut].
7. Press [▲] or [▼] to select the number of repetitions.
8. Press [ENTER].
 Cutting starts. If you set the repetition count to 2 or higher, a confirmation message will appear at the end of the job, asking whether you want to execute the next job. Press [PAUSE/RESUME] to execute the next job.
9. When the cutting is finished, press [ON/OFF LINE] to go back to the original screen.

RELATED LINKS

- P. 109 "Setting Overlap Cutting Using the Printer Driver"
- P. 54 "Sending Cutting Jobs from GreatCut-R"

Adjusting the Cutting-in Amount

When you want to perform accurate and fine adjustment of the cutting-in amount, such as when cutting material with thin carrier paper, you can obtain good results by adjusting the amount of blade extension. Turn the cap portion of the blade holder to adjust the amount of blade extension.

The amount of blade extension (③) is 0 mm (①) at minimum and 2.5 mm (98.42 mil) (②) at maximum. An adjustment of 0.5 mm (0.02 in.) can be made by rotating the cap one full turn.

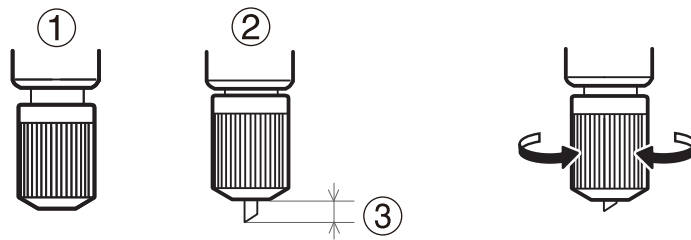

Rough estimate for the amount of blade extension:

Set the amount of blade extension (①) to an amount that is the sum of the thickness of the material portion (②) and half (④) the thickness of the carrier paper (③).

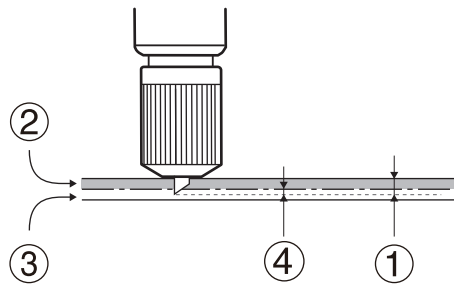

MEMO

If you are cutting perforated lines in material without carrier paper, set the amount of blade extension (①) so that when the cutter pierces the material (②), the blade extends slightly. Pushing the blade out too far will damage the blade and blade protector and hasten their deterioration, so exercise caution.

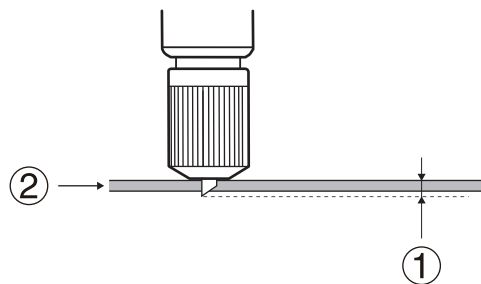

Cutting the Corners Longer to Make It Easy to Detach Cutting Data (Over Cut)

Cutting the top left corner of the cutting line slightly longer makes it easy to peel off the sticker. If the over cut function is enabled when cutting small characters or complex shapes, areas of the material that are required may be cut. Therefore, this function is turned off for normal use.

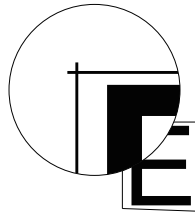

Procedure

1. Press [TOOL SELECT].
If material is loaded, press [ON/OFF LINE] to switch to offline mode.
2. Press [▶] to display the screen shown below.
The current value is displayed on the screen.
3. Press [▲] or [▼] to enter the over cut length.
4. Press [ENTER] to confirm your entry.
5. Press [ON/OFF LINE] to go back to the original screen.

```
Over Cut  0.00 mm ▲  
Select:◀  OK:ENTER▼
```

MEMO

- Default setting: 0.00 mm
- Setting range: 0.00 to 3.00 mm (0.00 to 0.12 in.) (changeable in 0.05 mm [0.01 in.] increments)

Cutting Small Text and Complex Graphics Cleanly (Tangential)

Corners and edges are cut cleanly when the material is cut with the tool blade facing the direction of travel. This setting is effective for cutting intricate designs, small text, or thick materials. We recommend that you set this to "Enabled" for normal use.

Procedure

1. Press [TOOL SELECT].
If material is loaded, press [ON/OFF LINE] to switch to offline mode.
2. Press [▶] several times to display the screen shown below.

3. Press [ENTER].
The current value is displayed on the screen.
4. Press [▲] or [▼] to set this to "Enabled".
5. Press [ENTER] to confirm your entry.
6. Press [ON/OFF LINE] to go back to the original screen.

MEMO

Default setting: [Disabled]

Smoothly Cutting Arcs and Other Curves (Smoothing)

You can set the curves in cutting data sent to this machine to be smooth. Normally, the smoothing function is set to "Enabled", but in cases where you are cutting small text or intricate shapes, set the smoothing function to "Disabled" in order to prevent the corners from being cut rounded. We recommend that you also set this to "Disabled" when you need to increase productivity regardless of quality.

Procedure

1. Press [TOOL SELECT].
If material is loaded, press [ON/OFF LINE] to switch to offline mode.
2. Press [▶] several times to display the screen shown below.

3. Press [ENTER].
The current value is displayed on the screen.
4. Press [▲] or [▼] to set this to "Enabled".
5. Press [ENTER] to confirm your entry.
6. Press [ON/OFF LINE] to go back to the original screen.

MEMO

Default setting: [Enabled]

Preventing and Correcting Misaligned Cutting

Keeping Material in Place and Stabilizing Cutting Accuracy

Turn on the suction fan to hold the material in place during cutting so as to prevent the material from lifting up or otherwise moving out of place. Normally, it is recommended that you use the machine with the suction fan turned on; however, the suction fan should be turned off when using materials that are thin and/or not firm. The strength of suction cannot be changed.

Procedure

1. Press [MISC].
If material is loaded, press [ON/OFF LINE] to switch to offline mode.
2. Press [▶] several times to display the screen shown below.

3. Press [ENTER].
The current value is displayed on the screen.
4. Press [▲] or [▼] to switch between "Enabled"/"Disabled".
5. Press [ENTER] to confirm your entry.
6. Press [ON/OFF LINE] to go back to the original screen.

MEMO

Default setting: "Enabled"

Correcting Distance during Cutting Based on the Thickness of Material

This correction should be performed when you want to accurately align the lengths of the cuts in the X and Y directions when cutting. This setting is applied to both cutting only and printing and cutting.

The movement distance of the material changes subtly depending on the material's thickness. This means that the length of a line when cut may differ from the length set in the cutting data.

MEMO

It is possible to correct only the feed direction (X direction) or the width (Y direction).

Procedure

1. Create cutting lines for a design whose feed direction (X direction) and width (Y direction) are set to the specified lengths.

Create a simple design, such as a square.

➤ P. 42 "Creating Cutting Lines Using a Generated Data Path"

Feed-direction (X direction) length	Width (Y direction) length
250 to 2000 mm (9.84 to 78.74 in.) (Create this in units of 250 mm [9.84 in.])	250 mm/500 mm (9.84 in./19.68 in.)

2. Load the material in the machine.

➤ P. 21 "Loading the Material"

3. Perform cutting output.

➤ P. 47 "Basic Cutting"

4. Measure the cut lengths (feed direction and width).

5. Press [MISC].

If material is loaded, press [ON/OFF LINE] to switch to offline mode.

6. Correct the output length in the material feed direction.

- (1) Press [▶] several times to display the screen shown below.

```
Image Scale Length
Select: ◀ OK:ENTER
```

- (2) Press [ENTER].
- (3) Press [◀] to select the number on the left and then press [▲] or [▼] to change the value to the feed-direction length created in step 1.
- (4) Press [▶] to select the number on the right and then press [▲] or [▼] to change the value to the feed-direction length actually cut.
- (5) Press [ENTER].

7. Correct the output length for the width.

- (1) Press [▶] to display the screen shown below.

```
Image Scale Width
Select: ◀ OK:ENTER
```

- (2) Press [ENTER].
- (3) Press [◀] to select the number on the left and then press [▲] or [▼] to change the value to 250 mm (9.84 in.) or 500 mm (19.68 in.) (length of width created in step 1).
- (4) Press [▶] to select the number on the right and then press [▲] or [▼] to change the value to the length of width actually cut.
- (5) Press [ENTER].

8. Press [ON/OFF LINE] to go back to the original screen.

Cutting Efficiently

Using Presets	120
Saving Cutting Conditions in Presets on the Operation Panel	120
Saving Presets Using the Printer Driver	121
Saving Presets with GreatCut-R	124
Reducing Cutting Output Time	126
Setting the Up Speed for Cutting	126
Setting the Acceleration Level for Up Speed	127
Setting the Crop Mark Detection Speed for the AAS Sensor	128

Using Presets

To save the time spent on setting up cutting conditions for every material changeover, you can save the cutting conditions for frequently used materials as presets. The next time you use the same material, you can change the settings to those suitable for the material simply by loading the preset you saved.

Saving Cutting Conditions in Presets on the Operation Panel

Up to four sets of cutting conditions, which include blade force, cutting speed, and offset, can be saved from the panel of this machine.

Procedure

1. Press [TOOL SELECT].

If material is loaded, press [ON/OFF LINE] to switch to offline mode.

The number of the currently applied preset is displayed. Normally 1 is displayed if no presets are registered.

MEMO

Preset names are fixed with numbers 1 through 4, and cannot be changed.



```
1 S 30 F 80 0 0.275 ▲
Select:◀ OK:ENTER▶
```

2. Press [▼] to select your desired preset number.

Register cutting conditions to the number selected here.

3. Press [ENTER].

4. Edit the cutting conditions: [SPEED], [FORCE], and [OFFSET].

The cutting conditions are saved to the selected preset number.

● P. 39 "Adjusting the Cutting Conditions"

Applying Presets

You can select a preset saved on the operation panel and apply it.

Procedure

1. Press [TOOL SELECT].

If material is loaded, press [ON/OFF LINE] to switch to offline mode.

The number of the currently applied preset is displayed.



```
1 S 30 F 80 0 0.275 ▲
Select:◀ OK:ENTER▶
```

2. Press [▼] to select the number of the preset for the cutting conditions you want to apply.

3. Press [ENTER].

Saving Presets Using the Printer Driver

You can save cutting conditions and cutting method settings to the printer driver.

Procedure

1. Display the driver's properties.

(1) Display the list of devices and printers.

- Windows 10:
Click [Start]>[Window System]>[Control Panel]>[View devices and printers].
- Windows 8.1:
Click [Start]>[PC settings]>[Control Panel]>[Devices and Printers].

(2) Right-click the icon of this machine.

(3) Click [Printer properties].

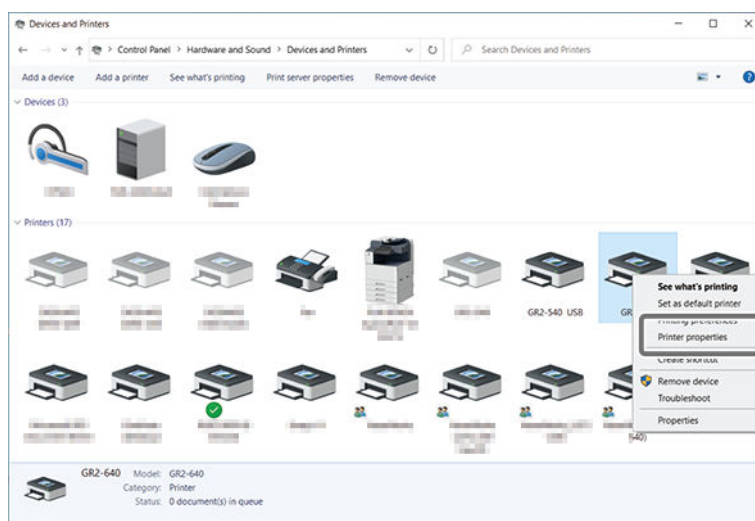

(4) Switch to the [Cutter] tab in the [Printer properties] window.

2. Edit the cutting conditions and cutting method settings (①) and click [Save] under [File Function].

Click [Save] to open the window for saving the preset file. Select a folder of your choice.

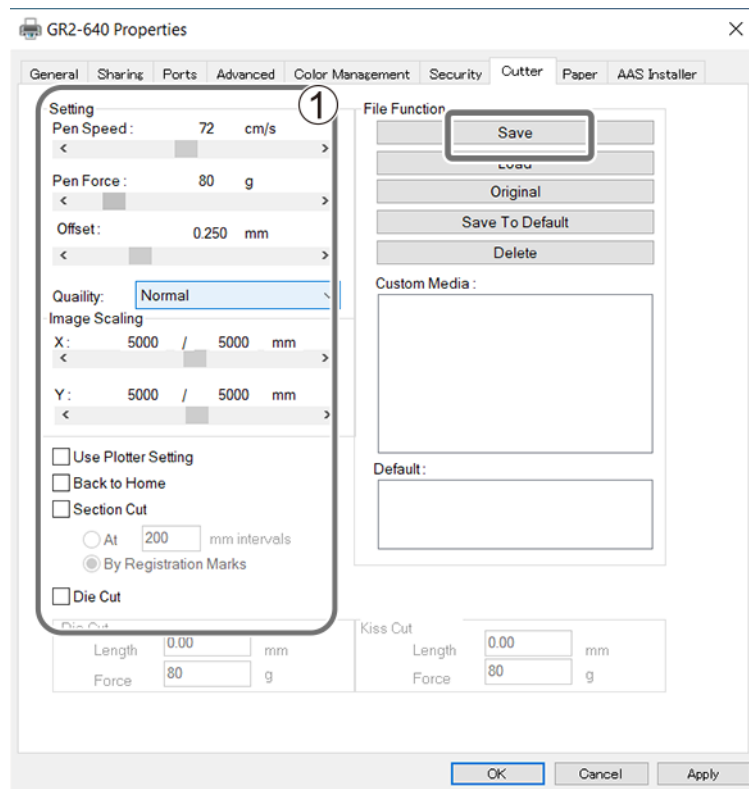

3. Enter a file name and save the file.

When naming the file, include the name of the material so that it is easy to distinguish it from other files. The file will have the extension GR2.

MEMO

To delete a preset file, manually delete it from the folder.

Loading and Applying a Preset

When sending a cutting job to the machine, open the [Printing Preferences] window and load the settings saved in a preset.

Procedure

1. Start Adobe Illustrator or CorelDRAW.
2. Click [File]>[Open] to open the data for cutting.
3. Open the [Printing Preferences] window.
 - P. 49 "Sending Adobe Illustrator Cutting Jobs from the Printer Driver"
 - P. 52 "Sending CorelDRAW Cutting Jobs from the Printer Driver"
4. Display the [Cutter] tab.
5. Click [Load] under [File Function].

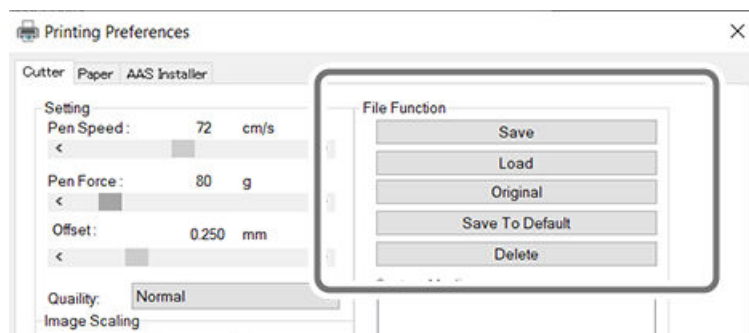

When loading the factory default settings (default settings), click [**Original**].

6. Select the preset file you want to load, and then click [**Open**].

The values of the selected preset are applied.

To display the current setting values in the [**Printing Preferences**] window upon launching the app, click [**Save To Default**].

MEMO

The saved preset is displayed in [**Custom Media**]. You can also double-click [**Custom Media**] to apply the preset. To delete the display of a preset from [**Custom Media**], click [**Delete**].

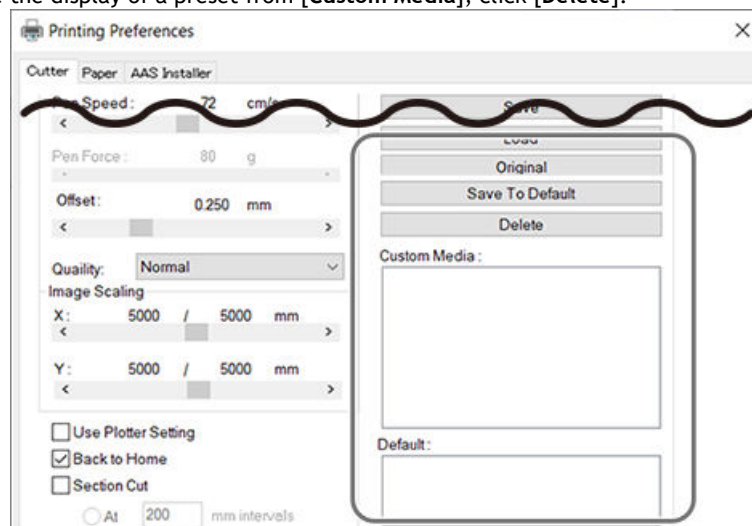

7. Click [**OK**] to close the [**Printing Preferences**] window.

Saving Presets with GreatCut-R

Procedure

1. Start GreatCut-R.
2. Click [Settings]>[Standard Settings]>[Output Parameters].

When the following screen appears, click [OK].

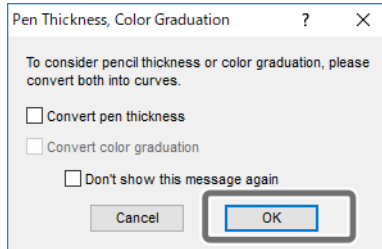

The [Output to device] window appears.

3. Select an option for [Device], [Mode], and [Output Profile] from their pull-down lists.

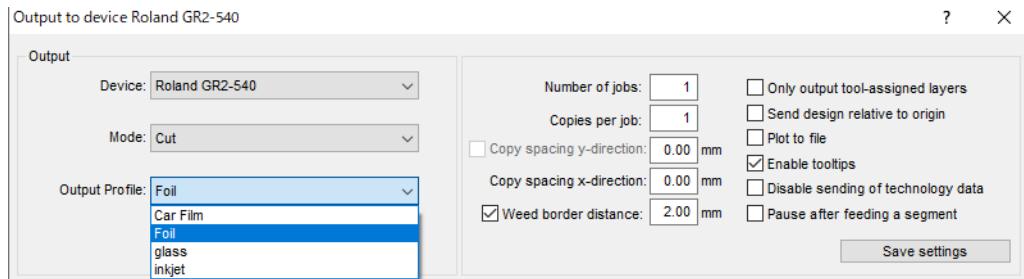

Setting item	Settings	Notes
[Device]	GR2-640/GR2-540	Select your device.
[Mode]	[Cut with AAS]/[Cut]/ [FlexCut]	[Cut with AAS]: For printing and cutting [Cut]: For cutting only [FlexCut]: For perforated cutting
[Output Profile]	[Foil]*1	

*1 The first time you perform this action, select the [Foil] saved as default, and after saving some settings as pre-sets, select the profile to use as reference.

4. Click the parameter values and edit them.

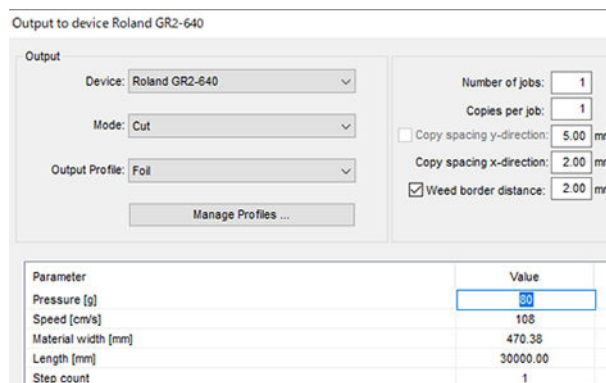

5. Click [Manage Profiles]>[Add].

The window for registering the preset name appears. When naming the profile, include the name of the material so that you can distinguish it from other files.

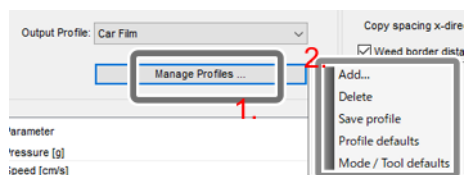

6. After entering the profile name, click [OK].
The profile is added to [Output Profile].

Reducing Cutting Output Time

Setting the Up Speed for Cutting

This setting lets you set the speed for moving the blade to the next cutting position with the blade lifted off the material during cutting operation. Using a faster up speed can shorten output time. If the material comes loose during no-load feeding and the blade damages the surface of the material, reduce the speed.

Procedure

1. Press [SPEED].
If material is loaded, press [ON/OFF LINE] to switch to offline mode.

2. Press [▶] several times to display the screen shown below.

The current value is displayed on the screen.

```
UP Speed: 72 cm/s ▲  
Select:◀ OK:ENTER▼
```

3. Press [▲] or [▼] to set the up speed for moving the blade to the next cutting data.
4. Press [ENTER] to confirm your entry.
5. Press [ON/OFF LINE] to go back to the original screen.

MEMO

- Default setting: 72 cm/s (28.34 in./s)
- Setting range: 3 to 153 cm/s (1.18 to 60.23 in./s) (changeable in 3 cm/s [1.18 in./s] increments)

RELATED LINKS

- P. 127 "Setting the Acceleration Level for Up Speed"

Setting the Acceleration Level for Up Speed

Set the blade's up speed during cutting (the speed at which the blade travels horizontally when it moves to the next cutting line after cutting one cutting line), and then set the blade acceleration.

Procedure

1. Press [SPEED].
If material is loaded, press [ON/OFF LINE] to switch to offline mode.

2. Press [▶] several times to display the screen shown below.
The current value is displayed on the screen.

```
UP Accel.: Medium ▲  
Select:◀ OK:ENTER▼
```

3. Press [▲] or [▼] to select the acceleration level.
You can select from three acceleration levels: "High", "Medium", and "Low".
4. Press [ENTER] to confirm your entry.
5. Press [ON/OFF LINE] to go back to the original screen.

MEMO

Default setting: "Medium"

RELATED LINKS

- P. 126 "Setting the Up Speed for Cutting"
-

Setting the Crop Mark Detection Speed for the AAS Sensor

Set the crop mark reading speed to be used when printing and cutting.

Procedure

1. Press [SPEED].

If material is loaded, press [ON/OFF LINE] to switch to offline mode.

2. Press [▶] several times to display the screen shown below.

The current value is displayed on the screen.

```
AAS Speed:Medium ▲  
Select:◀ OK:ENTER▼
```

3. Press [▲] or [▼] to select the crop mark detection speed.

You can choose from two levels of AAS detection speed: "Medium" and "Low".

4. Press [ENTER] to confirm your entry.

5. Press [ON/OFF LINE] to go back to the original screen.

MEMO

Default setting: "Medium"

RELATED LINKS

- P. 73 "Setting the Output-start Location (Printing and Cutting)"
-

Other Operations and Settings

Settings for Preventing Problems	130
Preventing Positioning Errors by Setting Material Feeding.....	130
Using the Material with Minimal Waste	132
Extending the Cutting Area in Specified Directions.....	132

Settings for Preventing Problems

Preventing Positioning Errors by Setting Material Feeding

Before starting cutting, set up the machine so that the material length necessary for cutting data is fed forward automatically beforehand, stabilizing the material feeding and preventing positioning errors. Also, feeding the material forward at the speed it is cut reduces the load on the motor. Be sure to set feeding for materials that require it.

IMPORTANT

This function is disabled when the [Single] mode is selected for material size measurement.

MEMO

Materials that Require Feeding

- Roll material
- Long, flat material that is longer than 1.6 m (63.00 in.)

Procedure

1. Press [MISC].

If material is loaded, press [ON/OFF LINE] to switch to offline mode.

The screen shown below appears.

```
Auto Unrolled Media
Select: ◀ OK:ENTER
```

2. Press [ENTER].

The current setting is displayed.

```
Disabled
Change: ▲▼ OK:ENTER
```

3. Press [▲] or [▼] to switch to "Enabled".

4. Press [ENTER].

The screen shown below appears.

```
Pre-feed Length ▲
Select: ◀ OK:ENTER ▼
```

5. Press [ENTER].

The current setting is displayed.

```
Pre-feed 600 mm
N:OFFLINE OK:ENTER
```

6. Press [▲] or [▼] to set the material length required for the cutting data.

It is a good idea to set a value that is about 500 mm (19.69 in.) longer than the required material length.

7. Press [ENTER].

The screen shown below appears.

```
Pre-feed Times ▲
Select: ◀ OK:ENTER ▼
```

8. Press [ENTER].

The current setting is displayed.

```
Times      1
N:OFFLINE OK:ENTER
```

9. Press [▲] or [▼] to set the number of test feeds.
The greater this number, the better positioning errors will be prevented.
10. Press [ENTER].
11. Press [ON/OFF LINE] to go back to the original screen.

MEMO

Default setting:

- "Auto Unrolled Media": "Enabled"
- "Pre-feed Length": 500 mm (19 in.)
- "Pre-feed Times": 1

Setting range:

- "Pre-feed Length": 500 to 15000 mm (19 to 590 in.) (changeable in 100 mm [4 in.] increments)
- "Pre-feed Times": 1 to 5

RELATED LINKS

- P. 31 "Measuring the Material Size"
-

Using the Material with Minimal Waste

Extending the Cutting Area in Specified Directions

Extending the cutting area allows for maximum material usage.

Procedure

1. Press [MISC].
If material is loaded, press [ON/OFF LINE] to switch to offline mode.
2. Press [▶] several times to display the screen shown below.

```
Paper Saving Mode
Select: ◀ OK:ENTER
```

3. Press [ENTER].
The current setting is displayed.
4. Press [▲] or [▼] to select the mode of extension.

<pre>Both Unexpanded Mode Change: ▲▼ OK:ENTER</pre>	Do not extend the length (X direction) or width (Y direction)
<pre>Length Expanded Mode Change: ▲▼ OK:ENTER</pre>	Extend the length (X direction)
<pre>Width Expanded Mode Change: ▲▼ OK:ENTER</pre>	Extend the width (Y direction)
<pre>Both Expanded Mode Change: ▲▼ OK:ENTER</pre>	Extend both the length (X direction) and width (Y direction)

5. Press [ENTER] to confirm your entry.
The screen shown below appears. If material is loaded, the size must be measured again. Raise the lever and measure the material.

```
Place Media And Then
Lower Down The Lever
```

MEMO

- Default setting: "Both Unexpanded Mode"
- Extended range:
 - Width: 20 mm (0.79 in.)
 - Length (feed direction): 50 mm (1.97 in.)

RELATED LINKS

- P. 31 "Measuring the Material Size"

Maintenance

Cleaning and Replacing Consumable Parts

Cleaning the Machine	135
Cleaning the Parts that Come into Contact with the Material	135
Cleaning the Blade Holder Cap.....	136
Replacing Consumable Parts	137
Replacing the Blade.....	138
Replacing the Blade Protector	140

Cleaning the Machine

Clean this machine periodically to ensure use under optimal conditions.

⚠ WARNING Be sure to perform operations as specified by the instructions, and never touch any area not specified in the instructions.

Sudden movement of the machine may cause injury or burns.

⚠ WARNING Never use a solvent such as gasoline, alcohol, or thinner to perform cleaning.

Doing so may cause a fire.

IMPORTANT

Disconnect the power cord before starting cleaning.

Do not use solvents, detergents with abrasive components, or strong cleansers. Using such cleaning products may cause damage to the surface of the cutting machine or movable parts.

Cleaning the Parts that Come into Contact with the Material

Wipe off dirt and grime with a cloth moistened with water and then wrung out firmly.

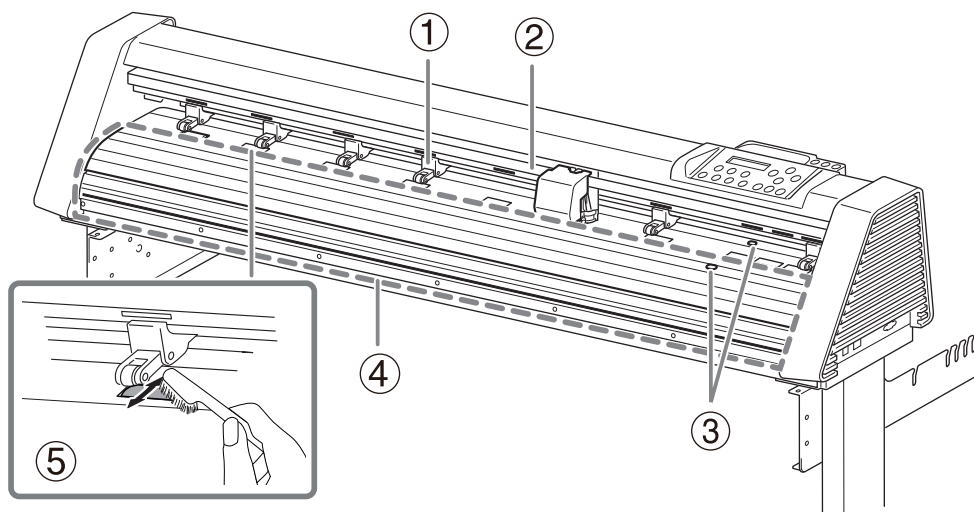

①	Pinch roller	Hold the roller with your hand so that it does not turn, and wipe off grime and material scraps from the rubber part of the pinch roller. Then, wipe clean with a dry cloth.
②	Carriage rail* ¹	Wipe away any dust and grime.
③	Paper sensors	After wiping away dust and grime, wipe clean with a dry cloth.
④	Platen	After wiping away dust and grime, wipe clean with a dry cloth.
⑤	Grit roller* ¹	After raising all of the pinch rollers, turn the grit roller while using a brush* ² to remove dust from the surface.

*1 When cleaning, move the cutting carriage away from where you are cleaning.

*2 Do not use a metal brush.

Cleaning the Blade Holder Cap

When a blade holder has been used for many hours, the bearing that supports the blade deteriorates, making it more difficult for the blade to turn. If you continue to use a blade holder that has deteriorated in this fashion, the machine will not cut cleanly because the tip of the blade will not turn smoothly. Also, if pieces of material or dust build up inside the blade holder cap, corners and curves will not be cut cleanly or the cuts will be perforated lines. In this situation, clean the blade holder cap.

⚠ CAUTION Never touch the tip of the knife with your fingers.
Doing so may result in injury. The cutting performance of the blade will also be impaired.

Loosen the cap to remove it, and remove any buildup of material or dust inside the cap.

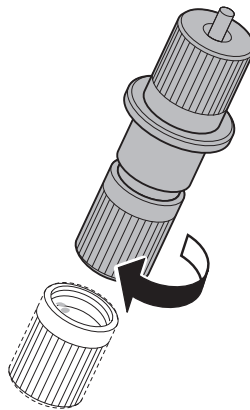
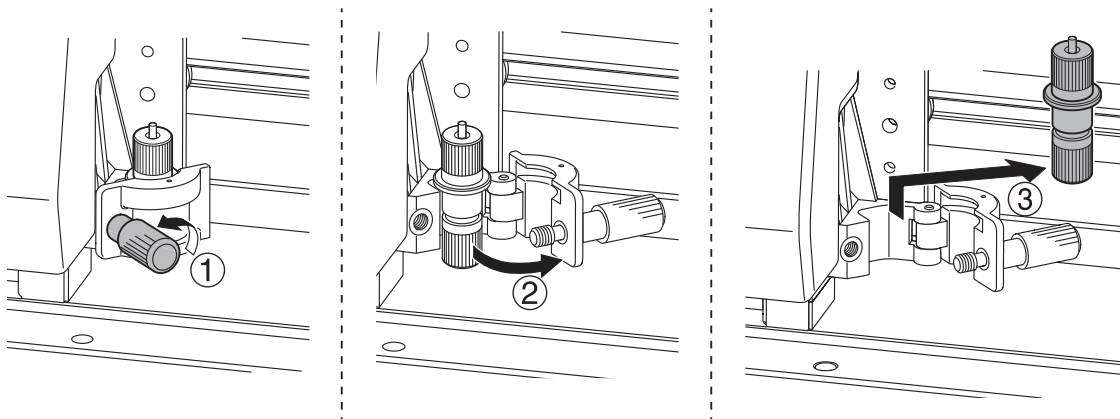

MEMO

If cleaning the blade holder cap fails to improve cutting, replace the blade holder with a new one.

Replacing Consumable Parts

To purchase consumable items, visit the Roland DG Corporation website (<http://www.rolanddg.com/>) or contact your authorized Roland DG Corporation dealer.

Blade

In the cases below, the blade has reached the end of its service life. Replace with new items.

- The tip of the blade is broken.
- Uncut areas remain even though the blade force has been increased to 50 to 60 gf.
- The cutting edge is dull.
- The material starts to curl up from the carrier paper when cutting detailed areas or corners.
- The tip of the blade has worn down due to long-term use or cutting hard material.

Blade holder

After the tip of the blade has been adjusted, the cap of the blade holder rubs against the material when cutting, causing the end of the cap to gradually wear away. As the cap becomes increasingly worn it becomes impossible to adjust the tip of the blade correctly, and clean cutting is no longer possible. When this happens, replace the blade holder with a new one.

Blade protector

In the cases below, replace the blade protector.

- The surface of the blade protector is deformed due to scratching or similar damage.
- The blade protector has deteriorated to the point it is falling apart.

Replacing the Blade

If the blade becomes dull, replace it with the included replacement blade.

⚠ WARNING Be sure to perform operations as specified by the instructions, and never touch any area not specified in the instructions. Sudden movement of the machine may cause injury or burns.

⚠ CAUTION Never touch the tip of the knife with your fingers. Doing so may result in injury. The cutting performance of the blade will also be impaired.

Procedure

1. Remove any material loaded in the machine.
2. Detach the cutting tool.

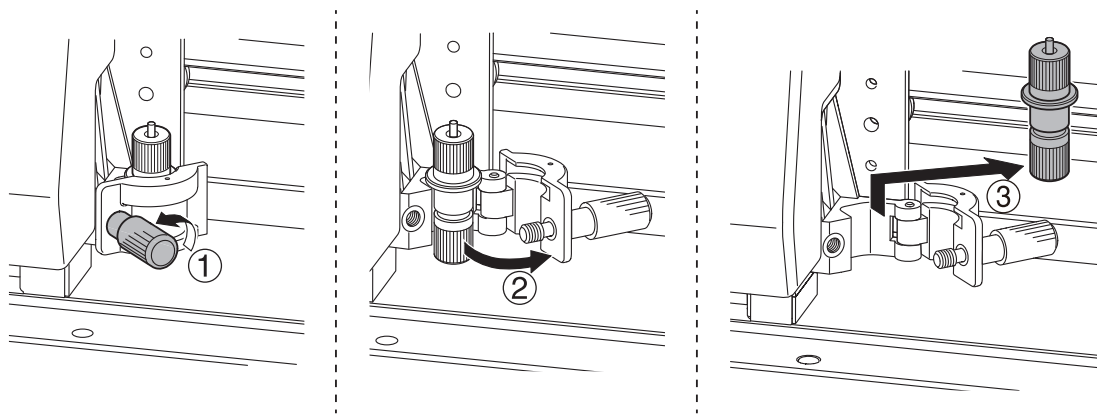

3. Replace the blade.
 - (1) Press the pin to push out the old blade.
 - (2) Insert a new blade.

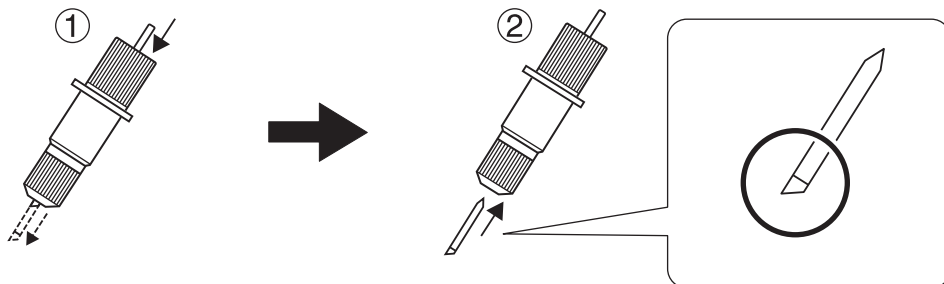

4. Install the cutting tool in the cutting carriage.

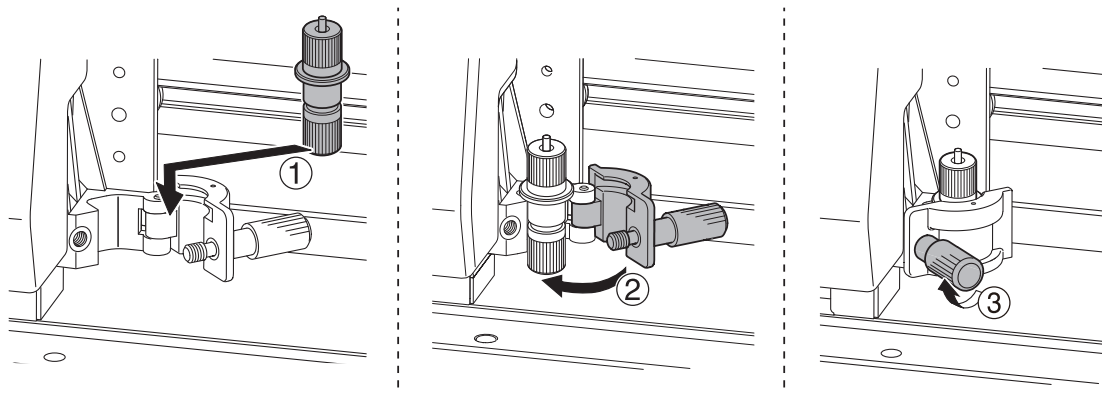

5. Ensure that the screw is tightened.

RELATED LINKS

- P. 32 "Remove the Material"
 - P. 112 "Adjusting the Cutting-in Amount"
-

Replacing the Blade Protector

If cutting is performed when the amount of blade extension or the blade force is not adjusted appropriately, the tip of the blade may pierce the carrier paper and scratch the blade protector. Replace the blade protector with the cutting pad supplied with this machine.

- ⚠ CAUTION** Be sure to perform operations as specified by the instructions above, and never touch any area not specified in the instructions.
Sudden movement of the machine may cause injury or burns.

Procedure

- 1. Remove the material.**
Raise the lever.

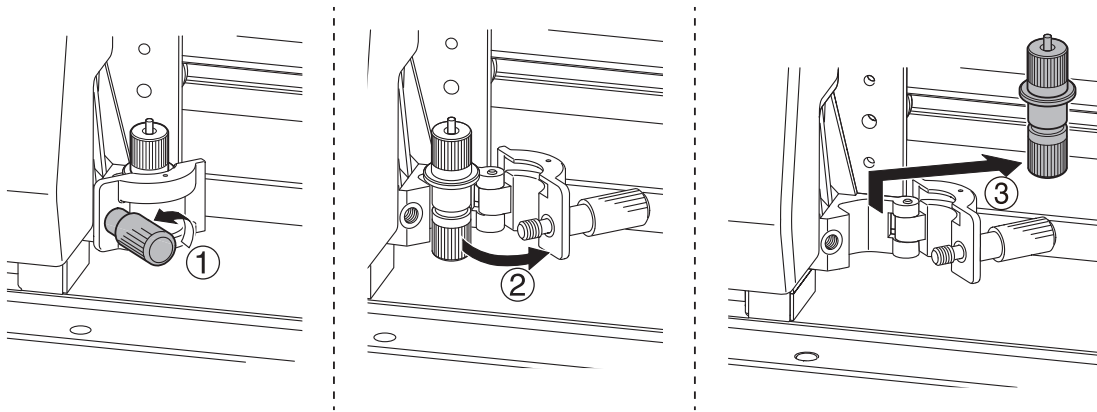

- 2. Move the cutting carriage to the edge.**
- 3. Remove the blade protector.**

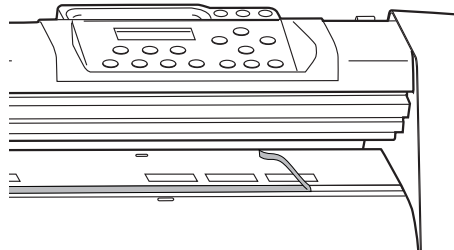

- 4. Affix the cutting pad where the blade protector was, ensuring that it is straight.**

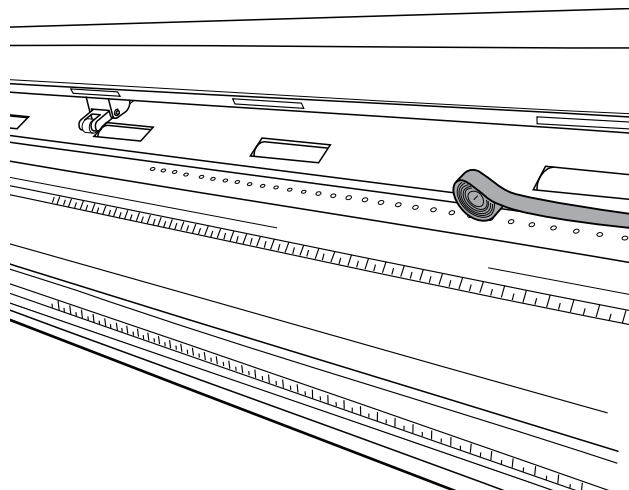

AAS Offset Test

Running an AAS Offset Test 142
Adjusting the AAS Offset 143

Running an AAS Offset Test

The AAS sensor's reading of crop marks may be out of position if the cutting carriage sustained a strong impact. If this is the case, send the AAS offset test file data to the machine from a computer on which File Uploader is installed and run an AAS offset test.

MEMO

The blade offset value is set for the AAS offset test. Enter the offset value according to the blade being used.

Procedure

1. Print any data stored in the downloaded AAS offset test file with a high-precision printer.
 - AASII_X_Y_Offset_Caberation_A4.eps (A4 size)
 - AASII_X_Y_Offset_Caberation_600_600.eps (Default settings data recommended for test use)
2. Turn on the power to the machine.
3. Load the material printed in step 1 in the machine.

Ensure that the material is loaded with the crop mark origin at the front right.

 - P. 21 "Loading the Material"
4. Press [**◀**], [**▼**], [**▲**] or [**▶**] to move the cutting carriage close to the crop mark origin.
 - P. 73 "Setting the Output-start Location (Printing and Cutting)"
5. Connect this machine and the computer with a USB cable.
6. Start File Uploader.
7. Select the transmission file and port for sending the file to the machine.
 - (1) Press [**Browse**] and select the prn file with the same conditions as the print data.
 - (2) Select the port for the cutting machine from the [**Select a port**] pull-down list.

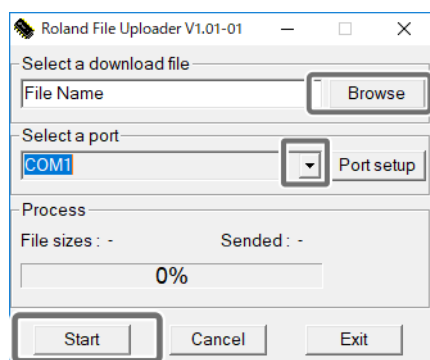

8. Click [**Start**].

The AAS offset test data is sent to the machine and cutting starts.
9. Check the AAS offset test result.

If there is any deviation in the intersections of printed lines and cut lines, adjust the AAS offset.

RELATED LINKS

- P. 143 "Adjusting the AAS Offset"

Adjusting the AAS Offset

If a shift has been found as a result of an AAS offset test, adjust the deviations in the width and length.

Procedure

1. Measure how much the cutting line (②) shifted using the printed lines (①) as a reference.

AAS offset test result

- Line parallel to the material-feed direction (③): X
- Line perpendicular to the material-feed direction (③): Y

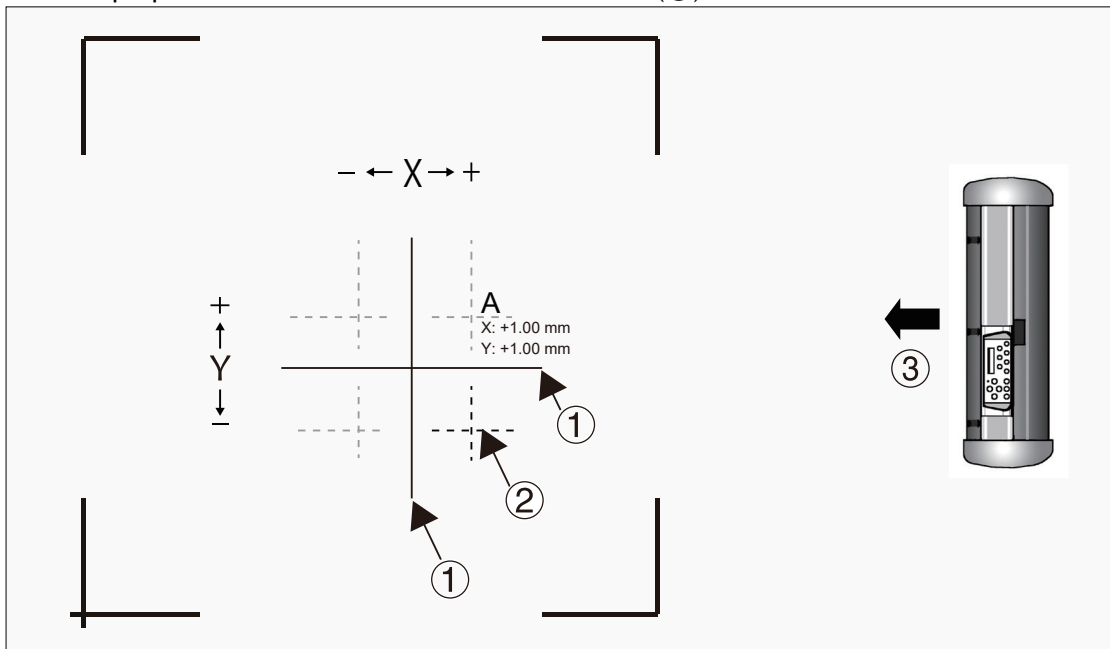

2. Press [MISC].
If material is loaded, press [ON/OFF LINE] to switch to offline mode.
3. Press [▶] several times to display the screen shown below.

```
AAS Offset
Select: ◀ OK:ENTER
```

4. Press [ENTER].
5. Press [▶] to move the cursor to X or Y, and then enter the offset value using [▲] or [▼].

```
AAS Offset      mm
▶ X:-1.000  Y:1.000
```

If the result is shifted to the positive direction, enter a negative offset. If the result is shifted to the negative direction, enter a positive offset. In the case of (A) in the sample AAS offset test result above, -1.00 is entered as the value for both X and Y.

6. Press [ENTER].
7. Press [ON/OFF LINE] to go back to the original screen.
8. Run an AAS offset test again.

RELATED LINKS

- P. 142 "Running an AAS Offset Test"

What to Do If

Machine Problems

The Machine Doesn't Run	146
Are cables connected?.....	146
Is the power switched on?	146
Is the POWER LED light on?	146
Are the communication settings correct?	146
Is the machine in online mode?	146
Are the software application settings correct?	146
Cutting Data Cannot Be Sent from the Operation Application	147
Has a communication error occurred?	147

The Machine Doesn't Run

Are cables connected?

Check that the power cord and the USB cable/network cable to the computer are connected correctly.

Is the power switched on?

If not, turn on the machine power.

Is the POWER LED light on?

Turn off the power to the machine and then turn it back on again. After turning on the power, if the LED light does not light up and the menu does not appear on the display of the operation panel, contact your authorized Roland DG Corporation dealer.

Are the communication settings correct?

If the cable connections are secure and no problem is found in the network, make sure that the IP address and other such settings are appropriate. The settings on both the machine and the computer must be appropriate. Redo the settings, checking to ensure that the machine's IP address set during the driver's installation process does not conflict with the IP address for another device on the network, that the machine's IP address is specified on the computer, that the output port and device are correctly specified and the settings are correct, and for other problems.

Is the machine in online mode?

If the display shows that the machine is in offline mode, cutting is not performed even when data is sent.

Press [ON/OFF LINE] to switch to online mode.

If material is not loaded, the machine cannot be switched to online mode. Load the material.

RELATED LINKS

- P. 21 "Loading the Material"
-

Are the software application settings correct?

Select the appropriate driver for the machine. For the selection procedure, refer to the manual for the application software.

Cutting Data Cannot Be Sent from the Operation Application

Has a communication error occurred?

Cutting data cannot be sent to the machine if communication is unstable or if a communication error has occurred.

If this data is not sent, change the way the machine and computer are connected.

- If the machine and computer are connected through a USB port, change the port that is used or connect over Ethernet.
- If the machine and computer are connected over a LAN, connect them through a USB port.

Cutting Output Problems

Crop Marks Are Not Detected.....	149
Is the material loaded correctly?	149
Are you using material that is not white or is glossy?	149
Are you using a transparent material?	149
Does the material have creases or wrinkles?	149
Are the crop marks blurred or are they in a color other than black?	149
Are the crop marks at the correct positions?	149
Is direct sunlight or high intensity indoor light hitting the machine?	149
Is the material loaded and set up straight and securely? Are the printing results crooked?.....	150
Are the size and shape of crop marks correct?	150
Is the printing expanded or reduced?	150
Is the crop mark line width appropriate?.....	150
Material Feeding Is Not Smooth	151
Is the material too thick?	151
Are the grit rollers dirty?.....	151
Is the material loaded and set up straight and securely?	151
The Material Slips Away from the Pinch Rollers during Cutting	152
Is the material loaded in parallel with the gradations of the ruler?	152
Is the material making contact somewhere during cutting?.....	152
Was the material feed checked before cutting (for roll material)?	152
Are the pinch rollers used to secure both edges of the material?.....	152
Material Lifts Up during Cutting and Gets Damaged by Blade	153
Is wide material being used?	153
Is the horizontal movement speed of the cutting carriage too fast?.....	153

Crop Marks Are Not Detected

Is the material loaded correctly?

Make sure that the material is loaded and set up correctly.

RELATED LINKS

- P. 21 "Loading the Material"

Are you using material that is not white or is glossy?

Crop marks cannot be detected if decorations or colors are on the material. Crop marks also cannot be detected on glossy material even if it is white.

Prepare a white, matte (minimally glossy) material and redo the process from the printing step.

RELATED LINKS

- P. 10 "Conditions for Usable Materials"

Are you using a transparent material?

Crop marks cannot be detected on transparent material. Change the material you are using.

RELATED LINKS

- P. 10 "Conditions for Usable Materials"

Does the material have creases or wrinkles?

Crop marks may not be read if the material has creases or wrinkles.

Stretch the creases or wrinkles out and load the material again. If the crop marks still fail to be read, prepare new material without creases or wrinkles and repeat the operation from printing the data.

Are the crop marks blurred or are they in a color other than black?

Set the color of crop marks to black, specify 100% printing density on your printer, and print the data again.

RELATED LINKS

- P. 71 "Printing Cutting Data on Material"

Are the crop marks at the correct positions?

Place the crop marks at the correct positions.

RELATED LINKS

- P. 61 "Setting the Margins and the Distance between Crop Marks"

Is direct sunlight or high intensity indoor light hitting the machine?

If direct sunlight or indoor light hits the cutting carriage sensor, crop marks may not be detected.

Move the machine to a location where it is not exposed to direct sunlight or indoor lighting.

Is the material loaded and set up straight and securely? Are the printing results crooked?

Crop marks cannot be detected if the second crop mark is angled beyond the allowable range in reference to the crop mark origin.

Ensure that the material is loaded or printed with straight crop marks.

RELATED LINKS

- P. 22 "Precautions for Loading Materials"
-

Are the size and shape of crop marks correct?

The machine can only detect crop marks in the prescribed shape.

Generate crop marks using the AAS plug-in or GreatCut-R.

RELATED LINKS

- P. 58 "Crop Mark Types"
-

Is the printing expanded or reduced?

If the size is expanded or reduced when printing, the crop marks cannot be read when cutting.

Print the data by specifying 100% for the magnification.

RELATED LINKS

- P. 71 "Printing Cutting Data on Material"
-

Is the crop mark line width appropriate?

It may not be possible to read crop marks if their lines are too thin.

Increase the width of the crop mark lines.

Material Feeding Is Not Smooth

Is the material too thick?

Use material with cuttable thickness. Some thick materials may make feeding unstable.

RELATED LINKS

- P. 10 "Conditions for Usable Materials"
-

Are the grit rollers dirty?

Check to make sure that the grit rollers are free of buildup of foreign material, such as material scraps. We recommend carrying out periodic cleaning.

RELATED LINKS

- P. 135 "Cleaning the Parts that Come into Contact with the Material"
-

Is the material loaded and set up straight and securely?

Feeding is not smooth when the material is not straight or is tensioned unevenly on the left and right. Reload the material.

RELATED LINKS

- P. 22 "Precautions for Loading Materials"
-

The Material Slips Away from the Pinch Rollers during Cutting

Is the material loaded in parallel with the gradations of the ruler?

If the front end of the material is cut at an angle, trim off the excess portion so that the front edge is parallel with the gradations of the ruler, and then load the material.

Is the material making contact somewhere during cutting?

Make sure that the left and right edges of the material do not make contact with the inner surfaces of the machine during cutting. Such contact not only damages the material, but also hinders normal material feed and causes the material to slip out of position.

Was the material feed checked before cutting (for roll material)?

If you start cutting without checking the material feed, correct cutting results may not be obtained. In the worst case, it may cause an error or malfunction or damage the material.

RELATED LINKS

- P. 23 "Loading Roll Material"
-

Are the pinch rollers used to secure both edges of the material?

If the pinch rollers are not placed within the range of the grit rollers, the material is not secured, which prevents it from being fed properly.

Reload the material.

Material Lifts Up during Cutting and Gets Damaged by Blade

Is wide material being used?

When using wide material, be sure to place pinch rollers on the grit rollers near the center of the material.

Is the horizontal movement speed of the cutting carriage too fast?

Reduce the horizontal movement speed of the cutting carriage. Additionally, reduce the cutting speed.

RELATED LINKS

- P. 126 "Setting the Up Speed for Cutting"
 - P. 127 "Setting the Acceleration Level for Up Speed"
-

Output Quality Problems

Printing and Cutting Are Misaligned	155
Is a thick material being used?	155
Is the sensor reading inaccurate?	155
Was the machine set to feed forward some amount of material before cutting?....	155
Uncut Areas Remain or Cut Edges Are Not Clean	156
Are the blade and blade holder securely mounted?	156
Is the tip of the blade broken?	156
Is there any buildup of dust or material adhesive on the tip of the blade?.....	156
Is there any buildup of pieces of material or dust inside the blade holder?	156
Is a thick material being used?	156
Are the blade force and cutting speed appropriate for the material being cut?.....	156
Is the amount of blade offset correct?.....	156
Is the smoothing function set to [Disabled]?	157
Is the blade protector damaged or deformed?	157
The Machine Cuts the Carrier Paper	158
Are the blade tip adjustment and blade force appropriate for the material being cut?.	158
.....	158
The Machine Cuts the Same Area Twice	159
Are there overlapping lines?.....	159
Is the step count set to 1 in GreatCut-R?.....	159
Misaligned Cutting Start and End Points	160
Was material feeding set?.....	160

Printing and Cutting Are Misaligned

Is a thick material being used?

Correct the cutting length according to the material actually used.

RELATED LINKS

- P. 117 "Correcting Distance during Cutting Based on the Thickness of Material"
-

Is the sensor reading inaccurate?

The AAS sensor's reading of crop marks may be out of position due to long-term use or a strong impact on the machine.

Run an AAS offset test.

RELATED LINKS

- P. 142 "Running an AAS Offset Test"
-

Was the machine set to feed forward some amount of material before cutting?

When using roll material or flat material longer than 1.6 m (63.00 in.), if cutting is performed without the material length required for the cutting data being fed forward, the material may slip or operation may stop due to a motor error.

Set the machine so that the necessary amount of the material is fed forward before cutting.

RELATED LINKS

- P. 130 "Preventing Positioning Errors by Setting Material Feeding"
-

Uncut Areas Remain or Cut Edges Are Not Clean

Are the blade and blade holder securely mounted?

Make sure the screws are tightened securely so that they do not come loose during cutting.

RELATED LINKS

- P. 138 "Replacing the Blade"

Is the tip of the blade broken?

If it is, then replace the blade with a new one.

RELATED LINKS

- P. 138 "Replacing the Blade"

Is there any buildup of dust or material adhesive on the tip of the blade?

If dirty, remove and clean the blade.

RELATED LINKS

- P. 138 "Replacing the Blade"

Is there any buildup of pieces of material or dust inside the blade holder?

Take off the tip of the blade holder and remove any pieces of material or dust inside.

RELATED LINKS

- P. 136 "Cleaning the Blade Holder Cap"

Is a thick material being used?

Correct the cutting length according to the material actually used. Additionally, reduce the cutting speed to increase the cutting quality level.

RELATED LINKS

- P. 117 "Correcting Distance during Cutting Based on the Thickness of Material"
- P. 40 "Setting the Cutting Speed"

Are the blade force and cutting speed appropriate for the material being cut?

Carry out a cutting test and adjust the settings until cutting can be performed adequately.

RELATED LINKS

- P. 37 "Performing a Cutting Test"

Is the amount of blade offset correct?

If the setting for the amount of blade offset is not correct for the blade, corners may be rounded or have horns.

Use an appropriate blade offset value.

RELATED LINKS

- P. 41 "Setting the Blade Offset"
-

Is the smoothing function set to [Disabled]?

To cut curves cleanly, set the smoothing function to [Enabled].

RELATED LINKS

- P. 115 "Smoothly Cutting Arcs and Other Curves (Smoothing)"
-

Is the blade protector damaged or deformed?

If the blade protector is damaged, the material may not be cut correctly even if the machine's settings and the installation of the blade and blade holder are all correct.

Replace the blade protector with the cutting pad supplied with this machine.

RELATED LINKS

- P. 140 "Replacing the Blade Protector"
-

The Machine Cuts the Carrier Paper

Are the blade tip adjustment and blade force appropriate for the material being cut?

Perform a cutting test and adjust the blade tip and blade force appropriately.

RELATED LINKS

- P. 36 "Recommended Cutting Conditions"
 - P. 37 "Performing a Cutting Test"
 - P. 112 "Adjusting the Cutting-in Amount"
-

The Machine Cuts the Same Area Twice

Are there overlapping lines?

The same data may have been copied, resulting in overlapping lines. Check the data.

Is the step count set to 1 in GreatCut-R?

If [Step count] is set to any value other than 1 under [Parameter] in the [Output to device] window or [Layer Settings] window, the value is added to the number of cuts.

Check the [Output to device] window or [Layer Settings] window.

RELATED LINKS

- P. 54 "Sending Cutting Jobs from GreatCut-R"
 - P. 99 "Configuring the Cutting Conditions Based on the Color of Cutting Lines"
-

Misaligned Cutting Start and End Points

Was material feeding set?

When using roll material or flat material longer than 1.6 m (63.00 in.), if cutting is performed without the material length required for the cutting data being fed forward, the cutting start and end points may be misaligned.

Set the machine so that the necessary amount of the material is fed forward before cutting.

RELATED LINKS

- P. 130 "Preventing Positioning Errors by Setting Material Feeding"
-

Messages on the Operation Panel

Messages	162
"File Too Large Press OFFLINE"	162
"Buffer Empty Press OFFLINE"	162
"Reboot Please"	162
"File size exceed 16M Please adjust"	162
"Please Stop Transmit File: Press OFFLINE"	162
"AAS Detect Fail"	162
Error Messages	163
"Error; Rollers Are /Up Sensor"	163
"Error; Check Media Or Drum Or X Motor"	163
"Error; Check Media Or Y Motor"	163
"Error; Check Carriag Sensor Or VC Motor"	163
"Out Of Space; # of Copies finished"	163
"HPGL/2 Cmd. Error"	163
"Communication Error Setup Press MISC"	163
"AAS File Command Error"	164

Messages

These are the main messages that appear on the machine's display to prompt correct operation. They do not indicate any error. Follow the prompts and take action accordingly.

"File Too Large Press OFFLINE"

File size exceeded memory buffer while repeating jobs.
Check the file size and resend the file.

"Buffer Empty Press OFFLINE"

Memory is empty when repeating a job.
Check the file and resend it.

"Reboot Please"

The machine must be restarted because it has been returned to the factory default settings.
Turn the machine off and then on again.

RELATED LINKS

- P. 19 "Restoring Default Settings"
-

"File size exceed 16M Please adjust"

AAS file size is over 16 MB.
Check the file size.

"Please Stop Transmit File: Press OFFLINE"

Output was canceled while a job was being processed.
Resend the job.

"AAS Detect Fail"

Automatic detection of crop marks failed.
Check the crop mark positions, and resend the job after increasing the length and width of crop marks for better readability.

Error Messages

This section describes the error messages that may appear on the machine's display and how to take action to remedy the problem. If the action described here does not correct the problem or if an error message not described here appears, contact your authorized Roland DG Corporation dealer.

"Error; Rollers Are /Up Sensor"

An error occurred during the measurement of material size.

Lower two or more pinch rollers.

RELATED LINKS

- P. 22 "Precautions for Loading Materials"
-

"Error; Check Media Or Drum Or X Motor"

An error occurred in the X motor.

After you switch off the power, inform your authorized Roland DG Corporation dealer of the message that appeared on the display.

"Error; Check Media Or Y Motor"

An error occurred in the Y motor.

After you switch off the power, inform your authorized Roland DG Corporation dealer of the message that appeared on the display.

"Error; Check Carriag Sensor Or VC Motor"

An error occurred in the VC motor.

After you switch off the power, inform your authorized Roland DG Corporation dealer of the message that appeared on the display.

"Out Of Space; # of Copies finished"

Material size is not sufficient for a cutting test.

Check the material and change the size.

"HPGL/2 Cmd. Error"

Machine received an undefined command.

Check the file settings.

RELATED LINKS

- P. 49 "Performing Cutting"
-

"Communication Error Setup Press MISC"

Communication settings between RS-232 and computer do not match when receiving commands from the computer.

Check the communication settings.

RELATED LINKS

- P. 17 "Viewing System Information"
-

"AAS File Command Error"

The orientation of the first crop marks in the computer file and that of the loaded material do not match when executing an AAS job.

Check the orientation of the printed material and in the transmission file.

RELATED LINKS

- P. 22 "Precautions for Loading Materials"
-

Appendix

Operations When Moving the Unit

Removing the Material and Blade Holder	167
Securing the Cutting Carriage and Pinch Rollers with Retainers	168
Removing the USB Cable Tie	169

Removing the Material and Blade Holder

Procedure

1. Raise the lever.
Remove any material loaded in the machine.

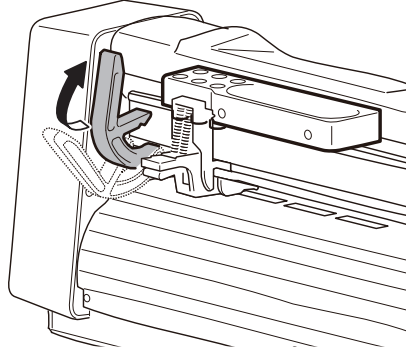

2. Detach the cutting tool.

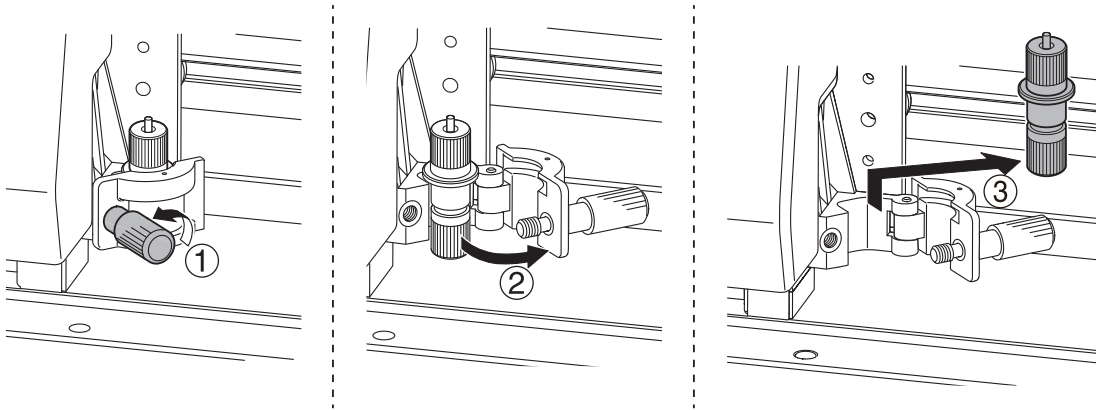

Securing the Cutting Carriage and Pinch Rollers with Retainers

Procedure

1. Prepare the retainers that were stored when installing the machine.
2. Place a retaining cushion between each pinch roller and blade protector.

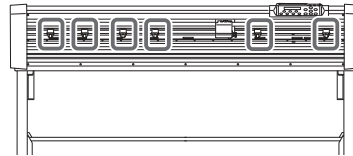
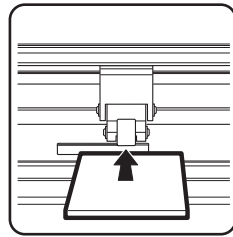

3. Wrap the cutting carriage with cushioning.

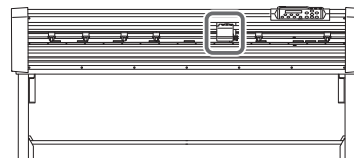
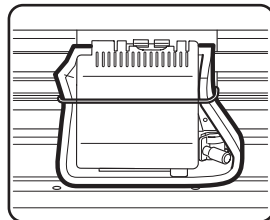

4. Using tape, fasten the lever in place so that it does not move.

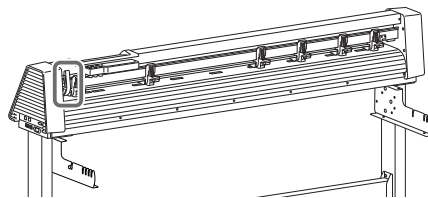
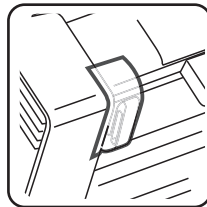

Removing the USB Cable Tie

The USB cable tie does not need to be removed and can be kept fixed onto the machine. When reattaching the USB cable tie after removing it, refer to the Setup Manual.

Procedure

1. Pull out the tip of the USB cable tie from the tie head.
2. Push the cable tie pin in and pull forward.
3. Loosen the cable tie.

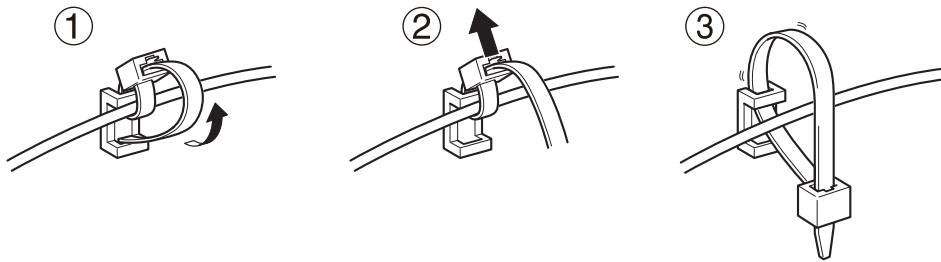
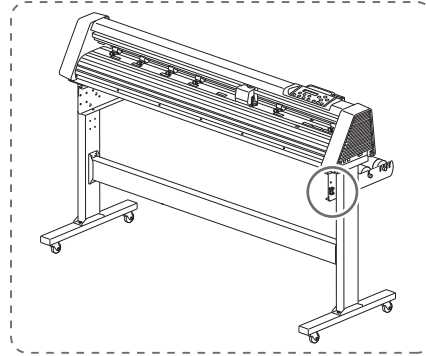

Memo

Company names and product names are trademarks or registered trademarks of their respective holders.

 Roland