

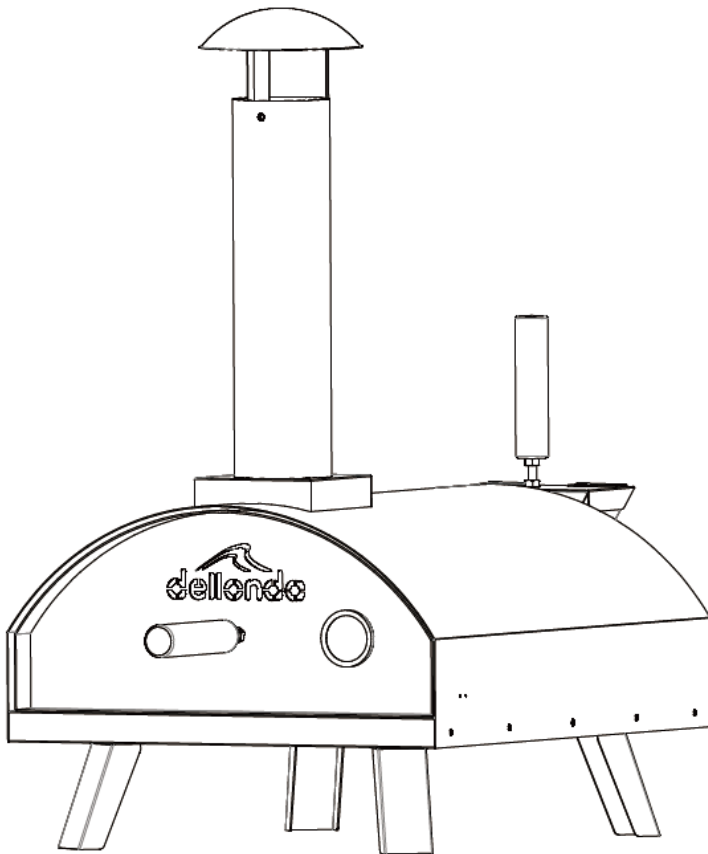

Portable Wood-Fired Pizza Oven & Smoking Oven



Model No's DG10, DG11

Thank you for purchasing a Dellonda product. Manufactured to a high standard, this product will, if used according to these instructions, and properly maintained, give you years of trouble-free performance.

Important Information

Please read these instructions carefully. Note the safe operational requirements, warnings & cautions. Use the product correctly and with care for the purpose for which it is intended. Failure to do so may cause damage and/or personal injury and will invalidate the warranty. Keep these instructions safe for future use.

Parts Diagram

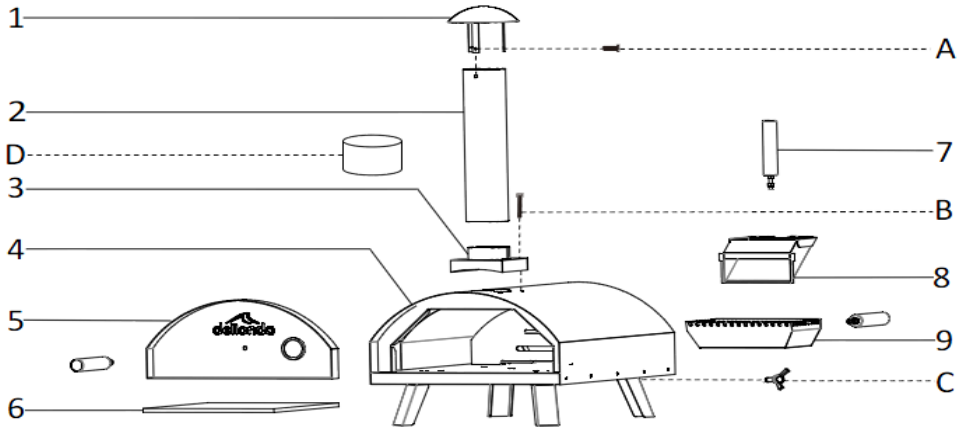

Part	Model No.	Description
1	DG10.01	Chimney Cap (Stainless Steel 'for DG10 only')
--	DG11.01	Chimney Cap (Stainless Steel) 'for DG11 only'
2	DG10.02	Chimney (Black) 'for DG10 only'
--	DG11.02	Chimney (Stainless Steel) 'for DG11 only'
3	DG10.03	Chimney Base (Black) 'for DG10 only'
--	DG11.03	Chimney Base (Stainless Steel) only'
4	DG10.04	Oven Body (Black) 'for DG10 only'
--	DG11.04	Oven Body (Stainless Steel) 'for DG11 only'
5	DG10.05	Door (Black) 'for DG10 only'
--	DG11.05	Door (Stainless Steel) 'for DG11 only'
6	DG11.06	Pizza Stone
7	DG11.07	Wooden Handle
8	DG11.08	Fuel Feed Box
9	DG11.09	Fuel Box
A	DG11.A	Screw M5
B	DG11.B	Screw M5
C	DG11.C	Butterfly Screw M5
D	DG10.D	Smoking Cap (Black) 'for DG10 only'
--	DG11.D	Smoking Cap (Stainless Steel) 'for DG11 only'



Refer to
instruction
manual



Wear
protective
gloves

About the Product

The Dellonda range of portable pizza ovens are the ideal companions for any outdoor cooking experience, whether it be large social gatherings away from home or an al fresco snack from the comfort of your own garden. Our portable, lightweight pizza ovens put the fun into cooking a variety of foods (not just pizza), including fish, meat, vegetables and much more. Extremely versatile they are also capable of smoking food using a detachable smoking cap that is included. An ideal maximum temperature range of 350-380°C enables you to cook your food just the way you like it. We recognise that people's tastes vary and with that in mind the resourceful DG10/11 pizza oven can be fuelled by either charcoal, hardwood or efficient and sustainable hard wood pellets (not included). We find that the optimum fuel is a mix of wood pellets with fine kindling and that natural fire lighters are great for getting the fire going. The DG10/11 is supplied with a stainless steel pizza paddle which easily aids the transfer of food to the cordierite stone board waiting inside which has been specifically engineered to withstand the high cooking temperatures. An optional cover/carry bag is available to purchase to protect the oven from adverse weather conditions when not in use and to aid transportation (Model No. DG12). Not recommended for use in strong winds.

Safety Instructions

- This product is intended for outdoor use only.
- **DO NOT** use indoors.
- Never leave a burning fire unattended.
- **DANGER** of carbon monoxide poisoning.
- **NEVER** light this product or let it smoulder or cool down in confined spaces.
- **DO NOT** use this product in a tent, caravan, car, cellar, loft or on a boat.
- **DO NOT** use under awnings, parasols or gazebos.
- **DO NOT** overload the unit with fuel.
- **FIRE HAZARD** - Hot embers may emit while

in use.

- **WARNING - DO NOT** use petrol, white spirit, lighter fluid, alcohol or other similar chemicals for lighting or relighting.
- This product is **ONLY** suitable for use with wood pellets, wood, logs or charcoal.
- **DO NOT** use this oven on any other flammable surfaces.
- Ensure that the oven is positioned at least 2 metres away from flammable items.
- **DO NOT** use this oven as a furnace.
- **DO NOT** handle or move the oven whilst alight as it will be hot.
- **ALWAYS USE** heat resistant gloves when in use as the unit will be hot.
- Allow the unit to cool down completely before moving or storing.
- **ALWAYS** keep children and pets at a safe distance from the oven when in use.
- **ALWAYS** inspect the unit prior to use for fatigue and damage.
- **DO NOT** use in high winds.

Assembly

Prior to assembly, read the instructions carefully. Check all parts against the parts list. Carry out assembly on a soft surface to avoid scratching the paint. Wear protective gloves during assembly. Please retain this information for future reference. For ease of assembly only loosely tighten bolts and then tighten fully when assembly is complete.

IMPORTANT - Remove any packaging before use, but retain the safety instructions and store them with this product.

STEP 1 - Attach 1 x wooden handle (7) to door (5) Attach wooden handle (7) to fuel feed box (8). Attach wooden handle (7) to fuel box (9). Each wooden handle has a lock nut, tighten it up against the wooden handle (7).

STEP 2 - Lift oven body and fold down the four legs to stand the oven up. Secure legs with butterfly screw M5 (C).

STEP 3 - Attach chimney base (3) to oven body (4) by 4 x screw M5 (B).

STEP 4 - Attach 1 x chimney cap (1) to chimney (2) by 3 x M5 screw (A) and feed chimney into the chimney base (3).

STEP 5 - Slide fuel feed box (8) onto the bracket on the rear of the oven body (4).

STEP 6 - Place fuel feed box (9) into the rear of the oven body (4).

STEP 7 - Place pizza stone (6) inside the oven.

STEP 8 - SMOKING OVEN - Remove chimney (2) and place smoking cap (D) over chimney base (3).

Positioning, Lighting, Usage & Care Information

- Please note that some fuels burn hotter than others and flames may cause the black powder coat finish to turn a lighter shade of grey or the stainless steel to discolour around the area of the flame. This is not a product fault, if desired the product can be repainted using high temperature resistant paint
- Ensure the oven is positioned on a permanent, flat, level, heat resistant non-flammable surface away from flammable items.
- Ensure the oven has a minimum of 2m overhead clearance and has a minimum 2m clearance from other surrounding items.
- Place untreated wood into oven. Do not use more fuel than 95% of fuel area capacity.
- Place rolled up newspaper and kindling in with the fuel and, using heat resistant gloves, light the fuel.
- Once the fuel has a coating of ash, place your food onto oven floor or pizza stone in the oven.
- If you wish to use as a smoking oven, add wood chips to the fuel and refer to Smoking (Assembly **STEP 8** and below).
- **DO NOT** overload the fuel feeding box (9) with fuel.
- Always use heat resistant gloves during the handling process and when refuelling.
- The unit may be left outside all year if a weatherproof cover is used to help protect it from bad weather.
- If left outdoors the oven will start to develop surface rust particularly after use. To help prevent surface rust the outside of the oven needs to be regularly oiled. First clean the surface with warm water and mild soap, allow to dry, and then brush with vegetable oil.

Food Cooking Information

- Please read and follow this advice when cooking.
- Always wash your hands before and after handling uncooked meat and before eating.
- Always keep raw meat away from cooked meat and other foods.

- Before cooking ensure stone surfaces and tools are clean and free of old food residues.
- **DO NOT** use the same utensils to handle cooked and uncooked foods.
- Ensure all meat is cooked thoroughly before eating.
- **CAUTION** - eating raw or under cooked meat can cause food poisoning (e.g. bacteria strains such as E.coli.)
- To reduce the risk of under cooked meat cut open to ensure it cooked all the way through.
- **CAUTION** - if meat has been cooked sufficiently the meat juices should be clear and there should be no traces of pink/red juice or meat colouring.
- After cooking always clean the cooking surfaces and utensils.

Cooking Pizzas

- Place the pizza into the oven when it reaches optimum temperature.
- It will take 10-15 minutes to reach the required cooking temperature.
- It is recommended to cook a pizza at or above 220°C, depending on user cooking preferences. The higher the temperature the quicker the cook time, **BUT** there is also a higher chance of charring. Practice makes perfect.
- The oven will reach a max. temperature of 350-380°C depending influencing factors such as ambient temperature, wind strength, fuel consumption and how often the door is opened.
- Check the fuel regularly and top up as necessary.
- Rotate pizza regularly to ensure even cooking.
- Check your pizza occasionally as they can cook quickly.

Cooking Other Foods

- This oven can be used to cook various other types of food, such as: fish, meat bread etc.
- Please fuel the oven as described under the lighting section.
- Place aluminium foil under the food to prevent it sticking to the oven floor.
- To keep meat moist, add a small amount of water to a small foil tray. Separate the coals in the lower fuel section and place the tray in the middle of the fuel before lighting.
- Top up the liquid as necessary using heat resistant gloves (not supplied).

Smoking

- To use as a smoking oven, add wood chips to the fuel.
- Allow oven to reach required temperature, then restrict air flow with smoking cap (D), refer to Assembly Step 8.
- To keep meat moist, add a small amount of water to a small foil tray. Separate the coals in the lower fuel section and place the tray in the middle of the fuel before lighting. Top up liquid as necessary.

Extinguishing

- To extinguish - stop adding fuel and allow fire to die. **DO NOT** use water as this could only damage the oven.

Storage

- When not in use cover with a waterproof cover once cooled. If left outdoors the oven will start to develop surface rust particularly after use. To help prevent surface rust the outside of the oven needs to be regularly oiled. First clean the surface with warm water and mild soap, allow to dry, and then brush with vegetable oil.

Environment Protection

Recycle unwanted materials instead of disposing of them as waste. All tools, accessories and packaging should be sorted, taken to a recycling centre and disposed of in a manner which is compatible with the environment. When the product becomes completely unserviceable and requires disposal, drain any fluids (if applicable) into approved containers and dispose of the product and fluids according to local regulations.

Dellonda Limited

Kempson Way, Suffolk Business Park, Bury St Edmunds, Suffolk. IP32 7AR



01284 757575



support@dellonda.co.uk



www.dellonda.co.uk