

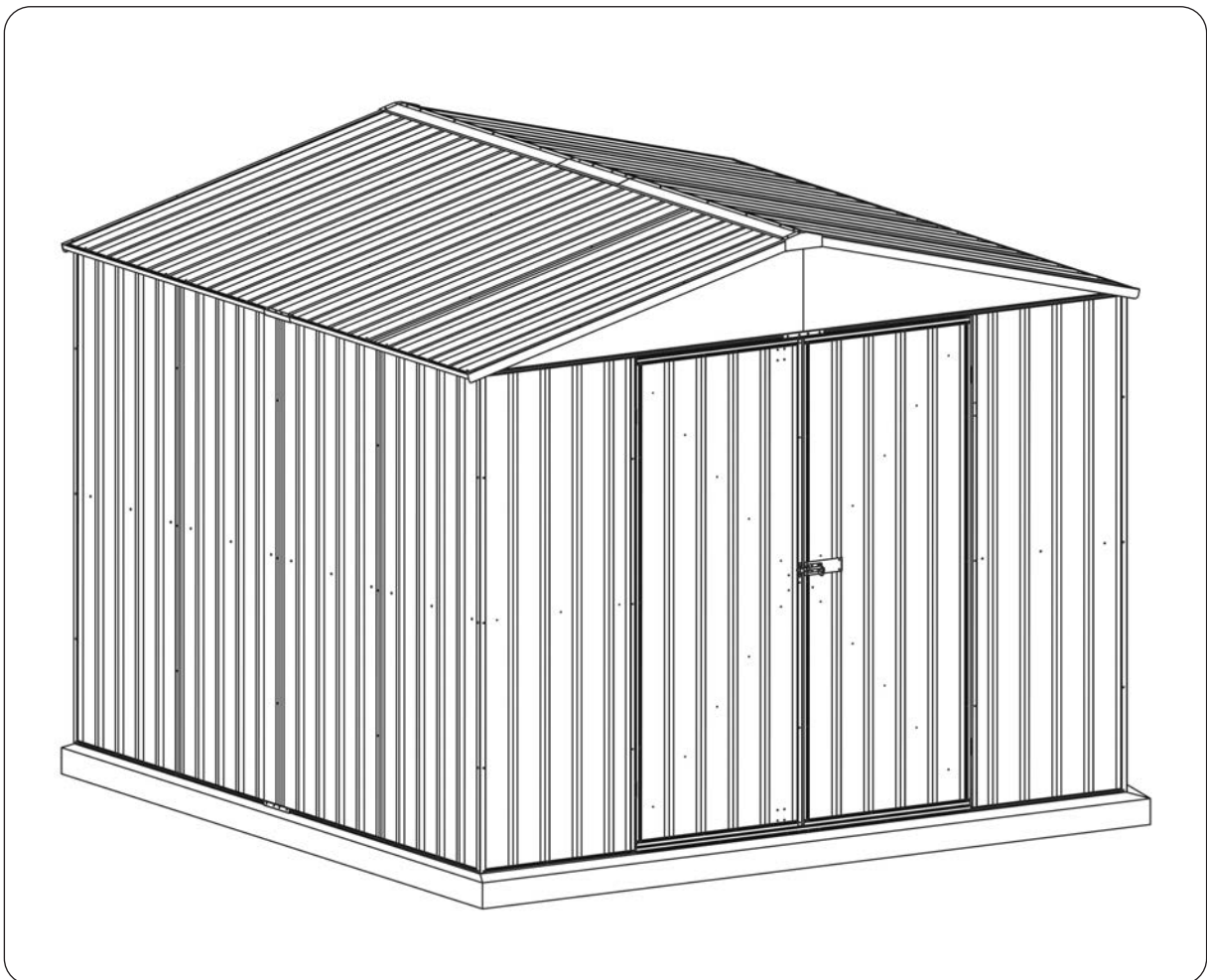

---

**Dellonda Galvanized Steel Garden/  
Outdoor Shed, 3 x 3 x 2.2m, Apex Roof -  
Green**



**Model No. DG116**

Thank you for purchasing a Dellonda product. Manufactured to a high standard, this product will, if used according to these instructions, and properly maintained, give you years of trouble free performance.

## Important Information

Please read these instructions carefully. Note the safe operational requirements, warnings & cautions. Use the product correctly and with care for the purpose for which it is intended. Failure to do so may cause damage and/or personal injury and will invalidate the warranty. Keep these instructions safe for future use.



Refer to instruction manual



Wear protective gloves



Wear eye protection



Wear safety footwear



Wear protective clothing

## About the Product

Galvanized steel panels easily screw and rivet together to form a rigid and secure structure. Features an apex style roof which gives extra water runoff. Double door fitted with cross bolt and eyelet that accepts padlock (not included) for additional security. Supplied with bolt down kit for secure fixing.

### • SPECIFICATION

- Model no: ..... DG116
  - Width: ..... 3000mm
  - Depth: ..... 3000mm
  - Height: ..... 2200\*mm
  - Doors ..... 2
  - Roof type: ..... Apex
- \* Denotes minimum wall height

## Safety Instructions

- **WARNING!** Ensure Health & Safety, local authority, and general workshop practice regulations are adhered to when building this shed.
- Keep children and unauthorised persons away from the working area
- **DO NOT** use the shed for any purpose other than that for which it is designed.
- Use appropriate safety clothing including eye protection.
- **NOTE:** The assembly of this product will require assistance.
- **DO NOT** attempt assembly in windy conditions.

## Concrete Plinth

- Concrete slab: Please ensure that your site is level. It is recommended that your slab is 100mm thick and you use builders plastic and F52 reinforcing mesh. We recommend that you make your slab 100mm bigger than the base dimensions of your shed. This will allow for a 50mm edge around your shed. We recommend that you slope the 50mm edges downward by 10 mm so that rain water will drain away from your shed.

## Assembly

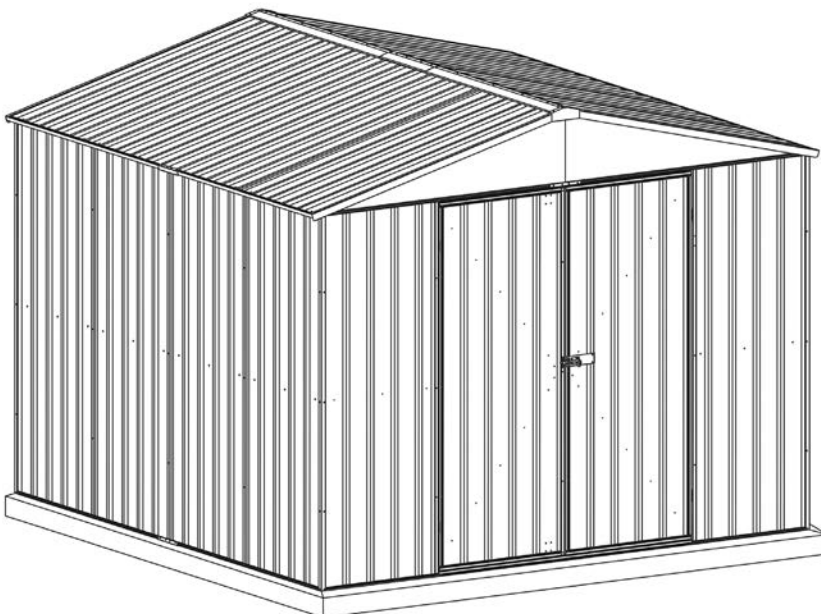

Tools required
Drill
Measuring tape
Cross head screw driver
Rivet gun
Rubber mallet
Sturdy ladder
Adjustable spanner
2 Saw horses
3mm and 4mm drill
10mm Masonry drill

### Build your garden shed in 7 easy steps!

- Step 1:** Check all parts against the component list
- Step 2:** Assemble the rear wall panels
- Step 3:** Assemble the side wall panels
- Step 4:** Assemble the roof panels
- Step 5:** Assemble the front wall panel
- Step 6:** Assemble the front door
- Step 7:** Fit the panels together





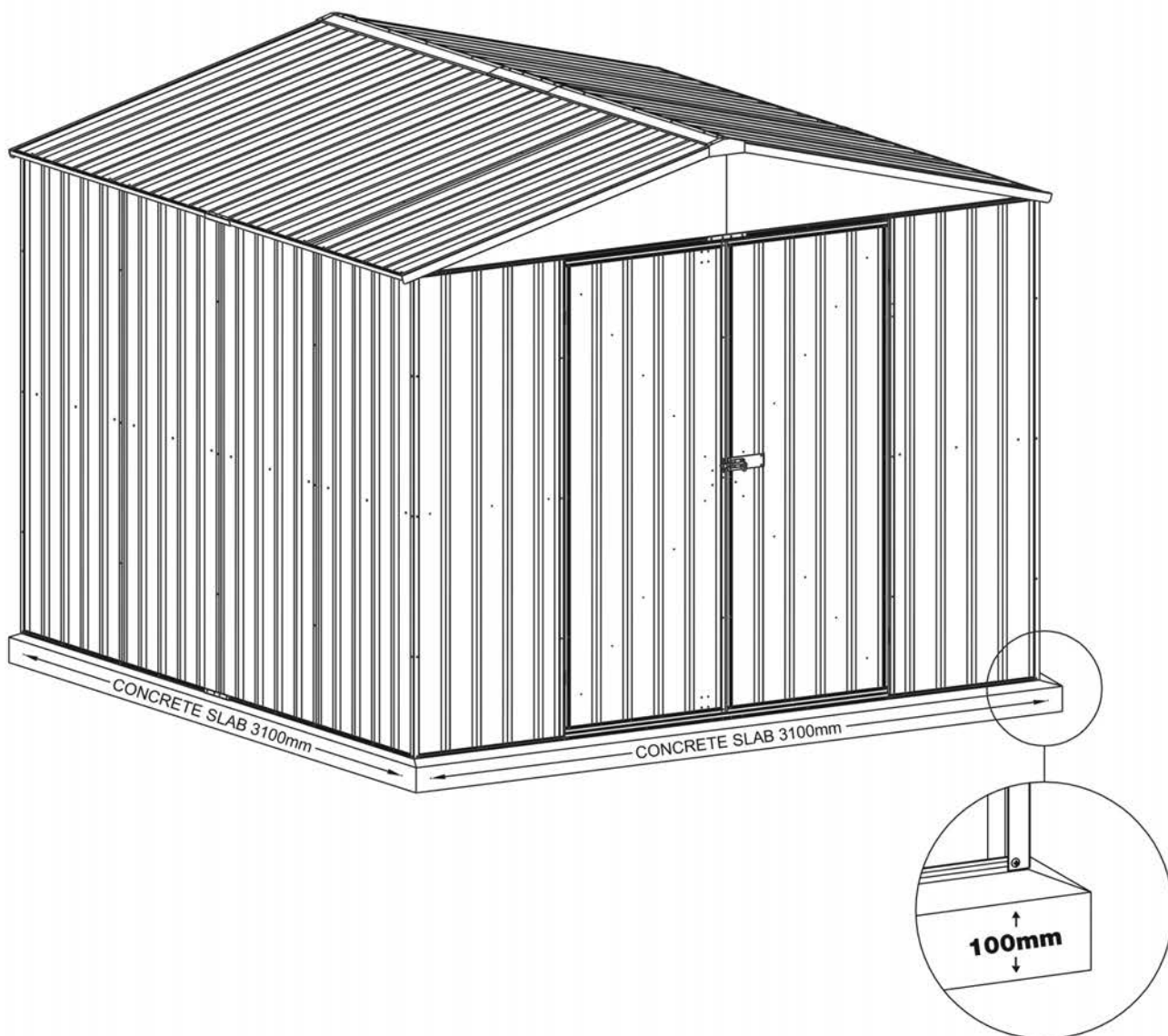



**IMPORTANT:** It is recommended that your new shed is secured to a concrete slab as per the specifications in this manual.

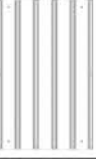











**Concrete slab:** Please ensure that your site is level. It is recommended that your slab is 100mm thick and you use builder's plastic and F52 reinforcing mesh. We recommend that you make your slab approximately 100mm bigger than the base dimensions of your shed. This will allow for a 50mm edge around your shed. We recommend that you slope the 50mm edges downward by 10mm so that rain water can drain away from your shed.





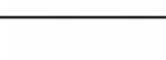





















**Step 1:** Check all parts against the component list



Lay out all parts with number facing outwards and check off against parts list.

Picture	Description	Component	Location	Part No.	QTY	Box No.	Check
	Sheet	Sheet 1800x770	rear wall side wall	18M	12	1	
	Sheet	Sheet 1579x770	roof	S30	2	2	
	Sheet	Sheet 1579x770	roof	S31	2	2	
	Sheet	Sheet 1579x770	roof	S32	4	2	
	Sheet	Sheet 1800x717	front	S94	1	2	
	Sheet	Sheet 1800x717	front	S95	1	2	
	Door Sheet	Sheet 1743x770	door	D18R	1	2	
	Door Sheet	Sheet 1743x770	door	D18L	1	2	
	Channel	Channel 1743	door	M24	1	1	
	Channel	Channel 1743	door	M25	1	1	















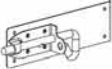



Picture	Description	Component	Location	Part No.	QTY	Box No.	Check
	Channel	Channel 1743	door	M41	1	1	
	Channel	Channel 768	door	M26	2	2	
	Channel	Channel 764	door	M27	1	2	
	Channel	Channel 764	door	M28	1	2	
	Jamb	Jamb 1743	door	J20	1	1	
	Brace	Brace 1075	door	U11	4	2	
	Channel	Channel 1494	side wall roof	27A	4	1	
	Channel	Channel 1494	side wall roof	27B	4	1	
	Channel	Channel 1494	rear wall	27C	1	1	
	Channel	Channel 1494	rear wall	27D	1	1	
	Channel	Channel 1494	roof	27E	2	1	
	Channel	Channel 1494	roof	27F	2	1	
	Channel	Channel 1494	rear wall	27H	1	1	

Picture	Description	Component	Location	Part No.	QTY	Box No.	Check
	Channel	Channel 1494	rear wall	27I	1	1	
	Channel	Channel 1494	side wall	27J	2	1	
	Channel	Channel 1494	side wall	27K	2	1	
	Channel	Channel 1494	front	27L	1	2	
	Channel	Channel 1494	front	27M	1	2	
	Channel	Channel 1494	front	27N	1	2	
	Channel	Channel 1494	front	27P	1	2	
	Channel	Channel 1549	front	28	1	2	
	Channel	Channel 674	front	33R	1	2	
	Channel	Channel 674	front	33L	1	2	
	Channel	Channel 1468	side wall rear wall	35R	3	2	
	Channel	Channel 1468	side wall rear wall	35L	3	2	
	Jamb	Jamb 1798	front	J3	1	1	

Picture	Description	Component	Location	Part No.	QTY	Box No.	Check
	Jamb	Jamb 1798	front	J4	1	1	
	Jamb	Jamb 1549	front	43	1	2	
	Corner Brace	Brace 1798	Corners	Z43	4	2	
	Lip	Lip 1582	roof	L4	4	2	
	Gable cap	Gable cap 1495	roof	E4	2	2	
	Connector	Gable cap connector 450	roof	E3	1	2	
	Ridge beam	Ridge beam 1495 zinc	roof	73	2	1	
	Gable R/H	Gable 1470	roof	G7	2	2	
	Gable L/H	Gable 1470	roof	G8	2	2	
	Logo cap	Logo cap	roof	95	2	2	
	Roof brace	Roof brace zinc	roof	96	2	1	
	Ridge beam connector	Ridge beam connector 450mm zinc	roof	67	1	1	

Picture	Description	Component	Location	Part No.	QTY	Box No.	Check
	Channel connector	Channel connector 188mm		66	11	2	
	Joining Brace	Brace	Door	W	2	2	

Fittings part list (Please note: all fittings in this list are located in Box 2):

Picture	Component	QTY	Picture	Component	QTY	√
	Self tapping screws(10mm)	420		Self tapping screws(16mm)	35	
	4x10mm Rivet	20		3x10mm Rivet	70	
	Pad bolt (part 70)	1		Keeper (part 71)	2	
	65x65mm barrel bolt plate (part 75)	1		5/16"x19mm Hexagonal bolt	11	
	Mid wall brace bracket (part 72)	4		60mm barrel bolt (part 74)	2	
	5/16" Hexagonal nut	11		Base bracket	11	
	Mid wall channel connector	3		Self tapper safety cover	40	
	Channel safety cover (L type)	1		Channel safety cover (R type)	1	
	Plastic stopper	8		Sleeve anchor bolt	11	





**Step 2:** Assemble the rear wall panels

You will find it easier to assemble your shed using sawhorses with timber studs attached (timber needs to be the same length as the shed ( 3.0 m)) or alternatively, a trestle table.

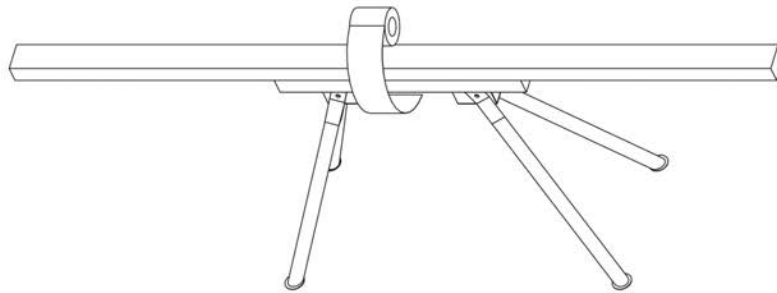

Place 4 x part 18M (sheeting) on your work table and join together with self-tapping screws as per the diagram below.

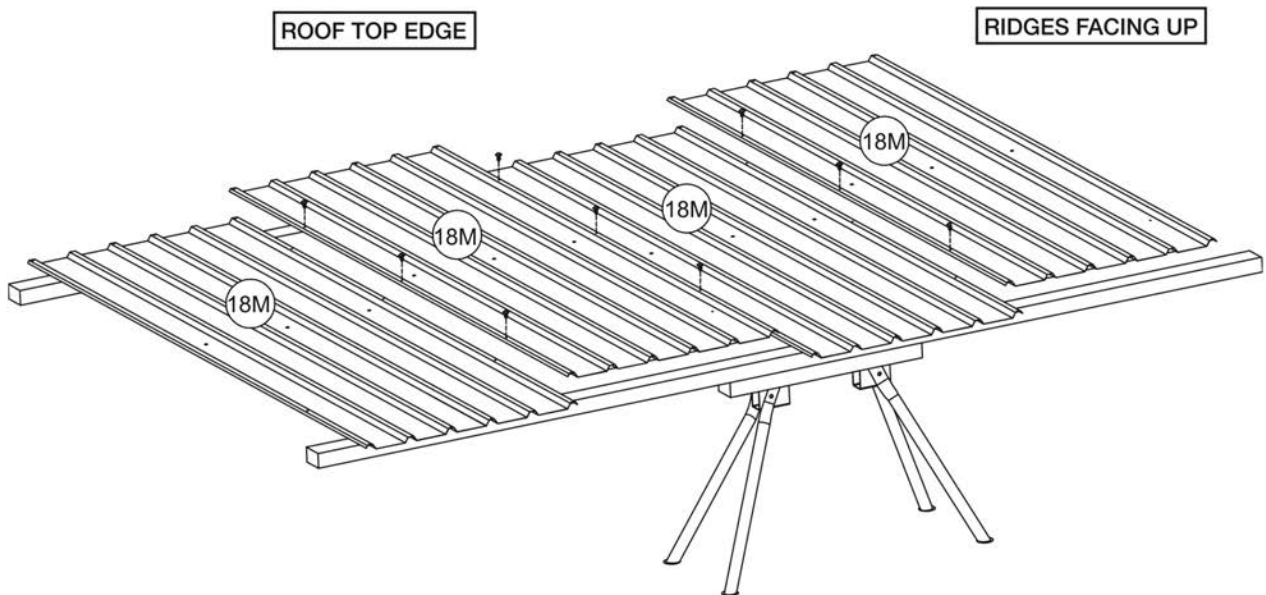

**Step 2:** Assemble the rear wall panels (continued)

Now fit parts 27I and 27H (top channel) and parts 27C and 27D (bottom channel) to the sheeting by tapping it in ( diagram A ) or sliding it in ( diagram B ). Make sure the small lip of the channel is always facing out. This ensures rain water cannot build up inside your shed. Make sure parts 27I and 27H are used as top side channels as per diagram A below.

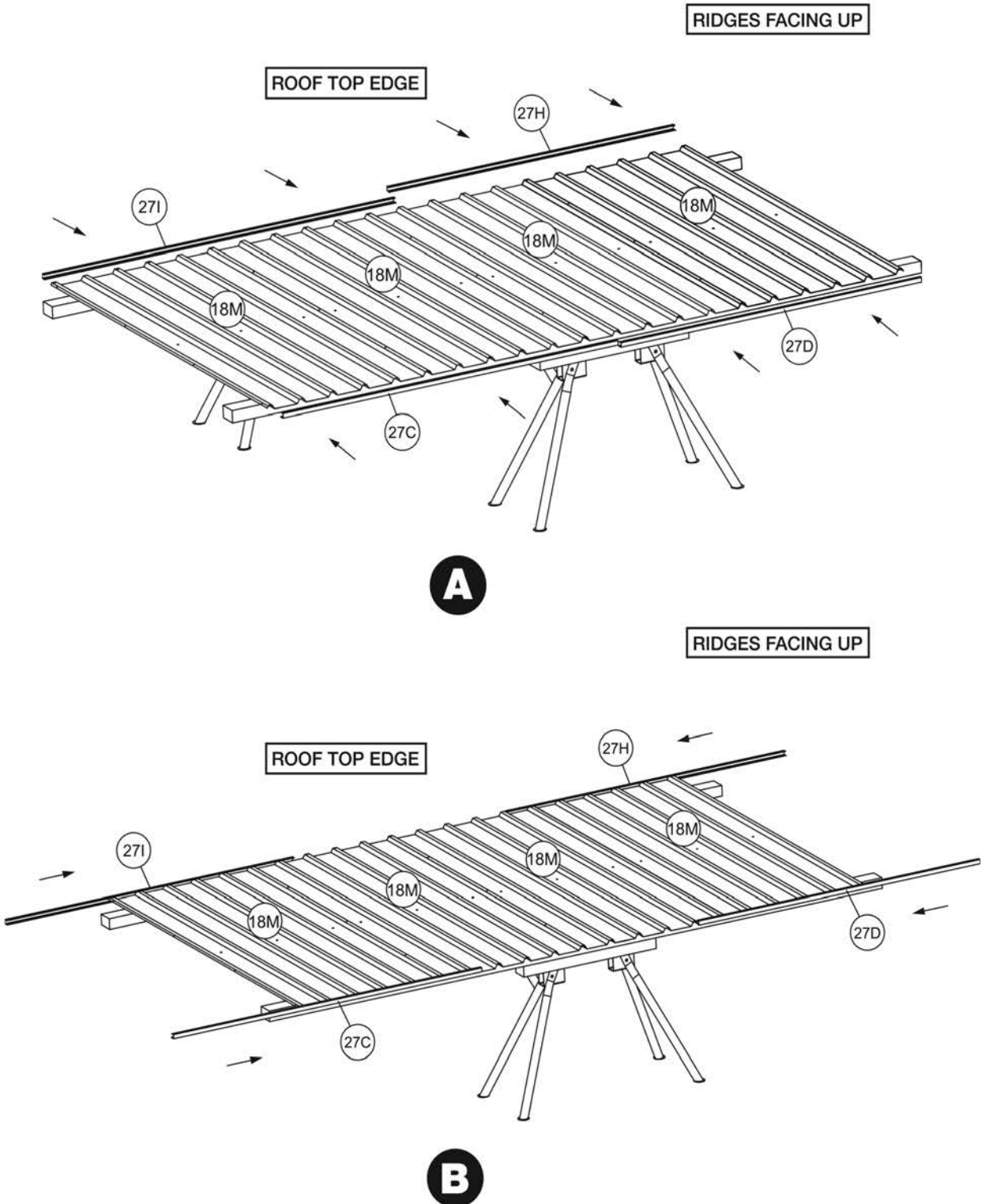

Tip: If panel and screw holes do not line up, try pulling panel to match up holes.

**Step 2:** Assemble the rear wall panels (continued)

Now fix parts 35R and 35L (mid wall channels) joined by mid wall channel connector to the sheeting with self-tapping screws.

Please note that the groove should face downwards. Fix other channels with self-tapping screws. **TIP (before applying connectors):** to help panel and screw holes to line up, fasten screws one at a time from one side of the wall to the other and pull panel away from screw each time to match up holes. Apply part 66 (channel connector) on top and bottom channels to enhance the strength.

**NOTE:** Screws are applied to both sides of the connectors. All screws marked with a cross should not be fixed at this stage.

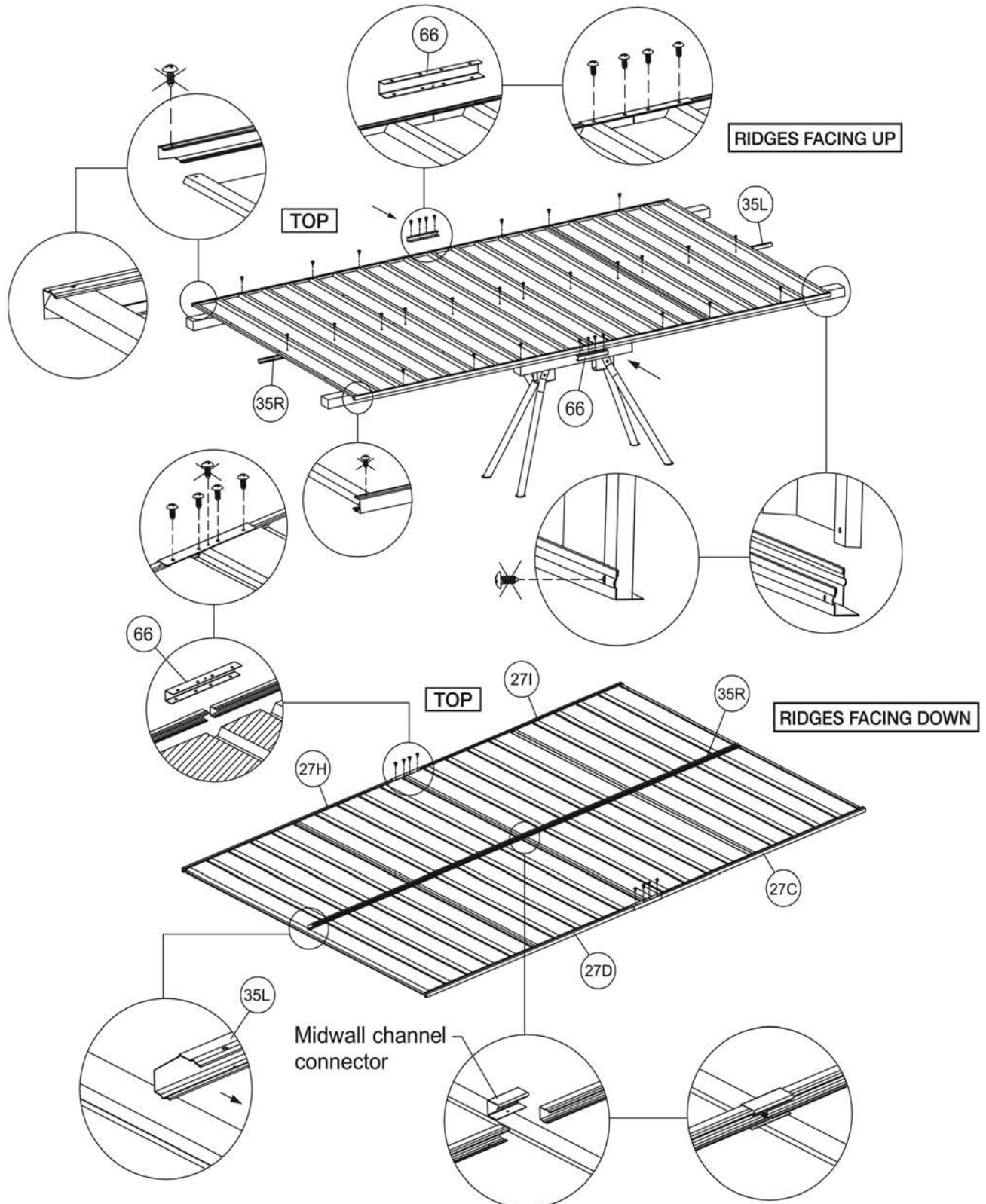

### Step 3: Assemble side wall panels

Place 4 x part 18M (sheeting) on your worktable and join together with self-tapping screws as per the diagram below. Now fit parts 27K and 27J (top channel) and parts 27A and 27B (bottom channel) to the sheeting by tapping or sliding it in. Make sure the small lip of the channel is always facing out. This ensures rainwater cannot build up inside your shed. Make sure parts 27K and 27J are used as top side channels. **TIP (before applying connectors):** to help panel and screw holes to line up, fasten screws one at a time from one side of the wall to the other and pull panel away from screw each time to match up holes. Now fix parts 35R and 35L (mid wall channels) joined by a mid wall channel connector to the sheeting with self-tapping screws. Please note: the groove should face downwards. Fix channels with self-tapping screws and apply part 66 (channel connectors) to enhance the structural strength. Note that screws are applied to both sides of the connectors.

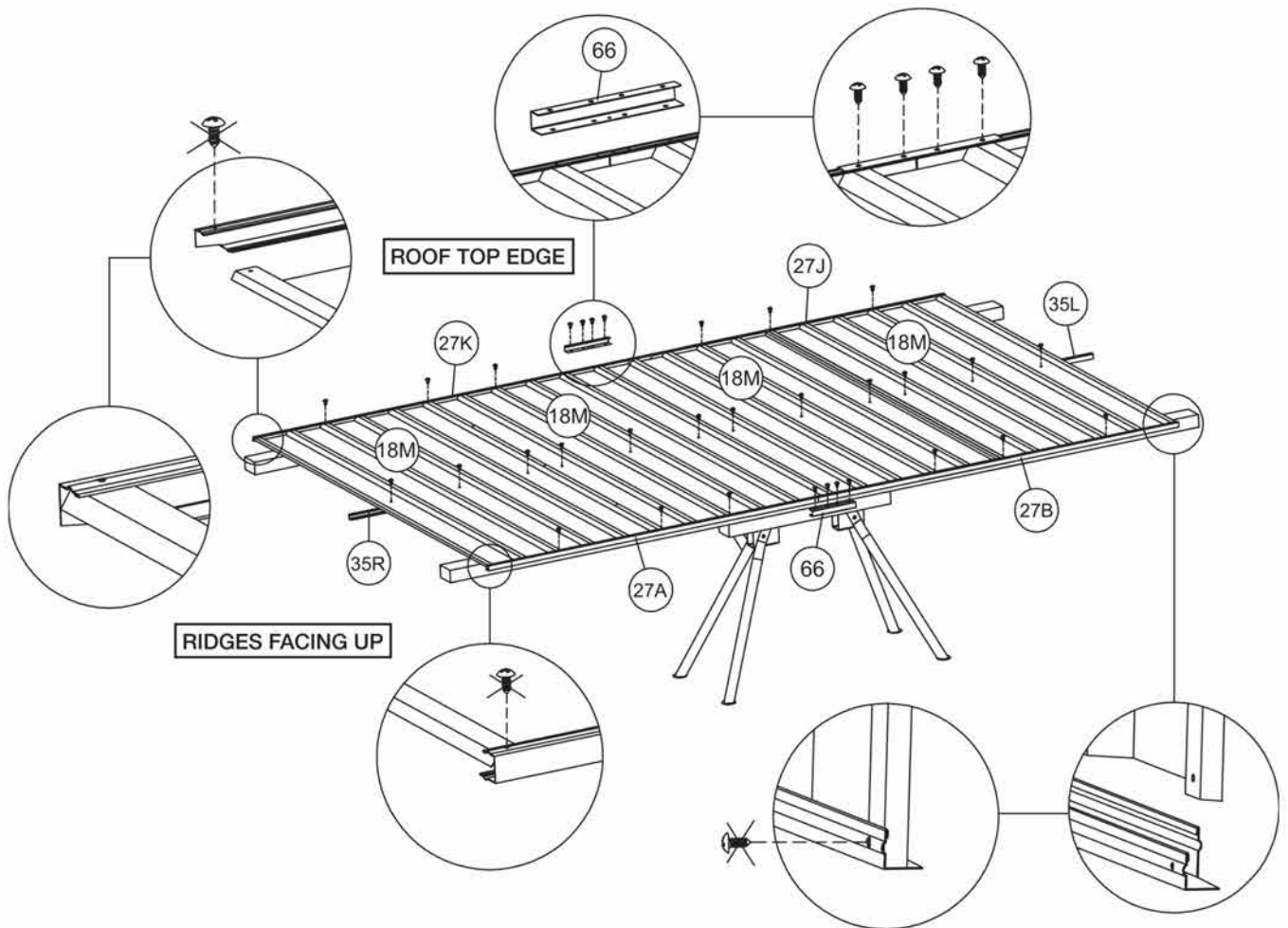

**Step 3:** Assemble side wall panels (continued)

All screws marked with a cross should not be fixed at this stage. Repeat the same steps for the other side wall. Make sure the small lip of the channel is always facing out. This ensures rain water cannot build up inside your shed.

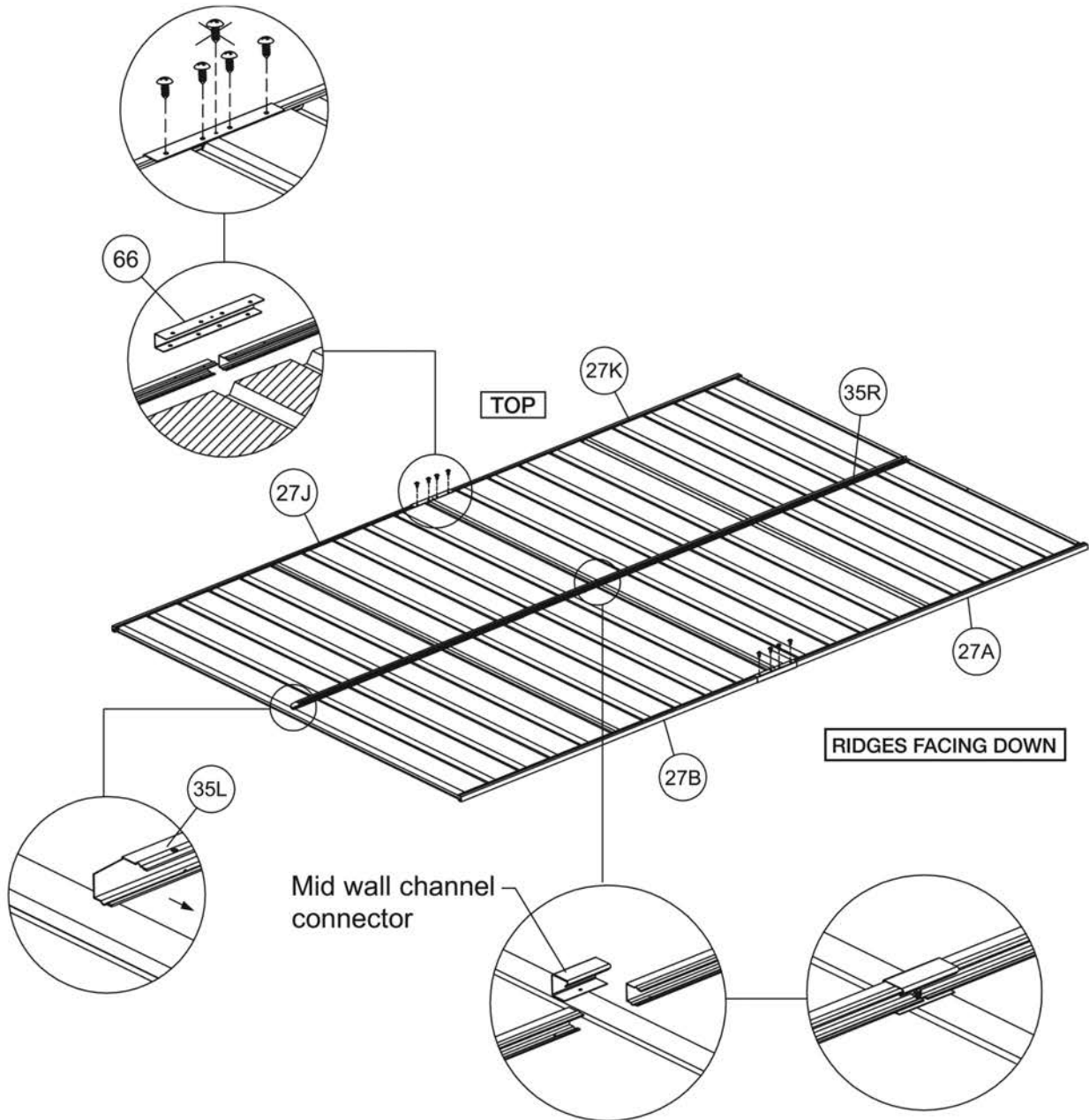

**Step 4:** Assemble the roof panels

Place parts S30, S31 and 2 x part S32 (sheeting) on your worktable and join together with self-tapping screws as per the diagram below.

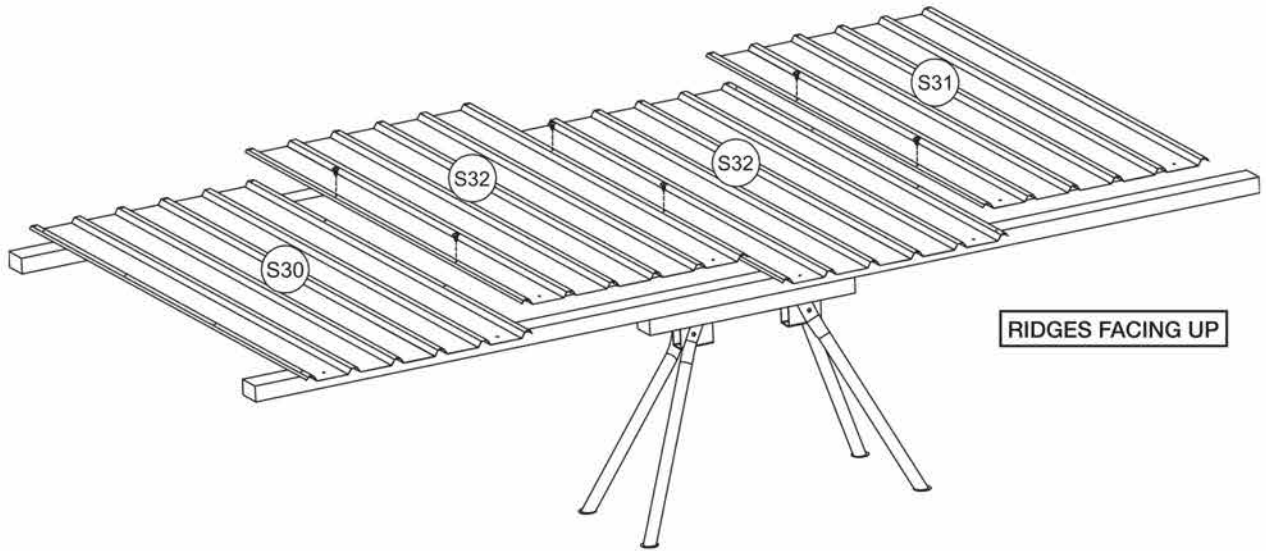

Fix parts 27F, 27E, 27A and 27B (channels) using self-tapping screws as per the diagram below. Please ensure parts 27A and 27B are attached to the side of the sheeting which has pre-punched holes as per the diagram below. Make sure the small lip of the channel is always facing out. This ensures rain water cannot build up inside your shed.

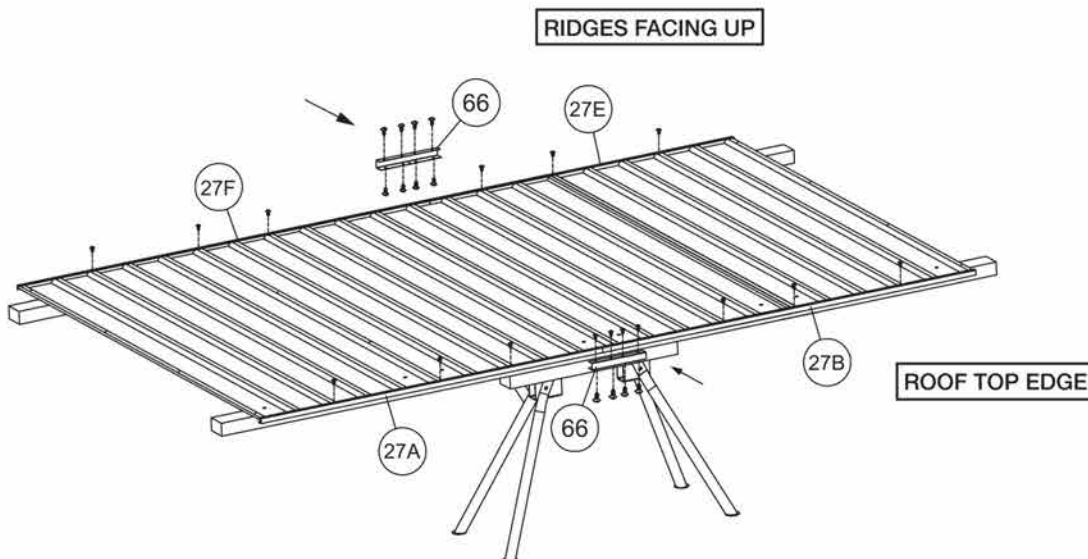

Enhance the structural strength by applying part 66 (channel connectors). Note that screws are applied to both sides of the connectors as per Step 3.

**Step 4:** Assemble the roof panels (continued)

Leave 4 corners unfixed in this stage. Repeat the same steps for the other roof panel.

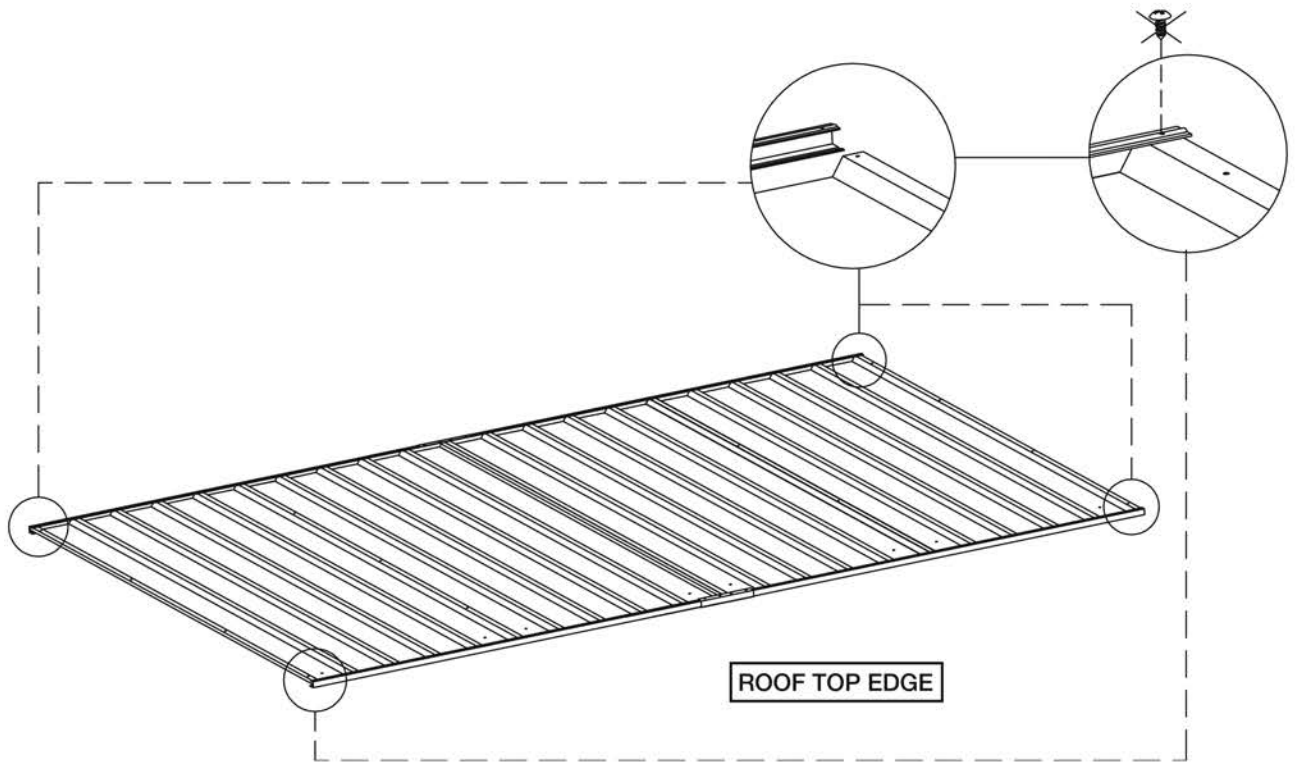



**Step 5: Assemble the front wall panels**

Fix parts J3 and J4 (jamb) to parts S94 and S95 (sheeting) with self-tapping screws. Please note: All screws marked with a cross should not be fixed at this stage.

**Note:** Holes drilled in the edge of this sheet are not a defect. They are there to allow the door hinge rivets clearance through this sheet.

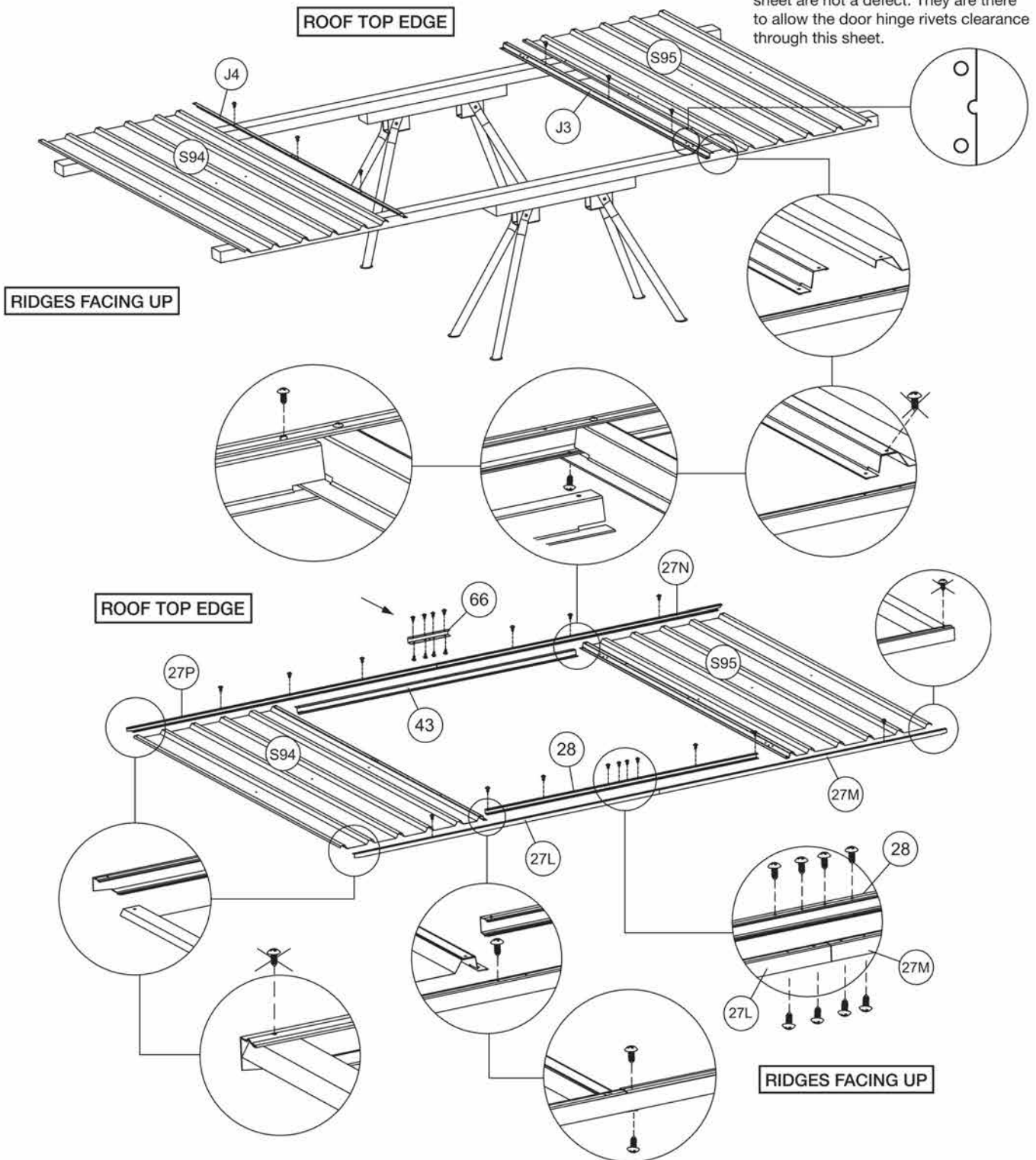

Fix parts 27P and 27N (top channels), part 43 (jamb), and parts 27L, 27M, and 28 (bottom channels) using self-tapping screws. Enhance the top channels by applying part 66 (channel connector) and fix screws through both sides. Please note: for parts 27P, 27N, 27L and 27M the small lip should be facing out to stop water building up and leaking into shed.

**Step 5:** Assemble the front wall panels (continued)

Now fix parts 33R and 33L (mid wall channels) to the sheeting using self-tapping screws. Please note the groove should face downwards.

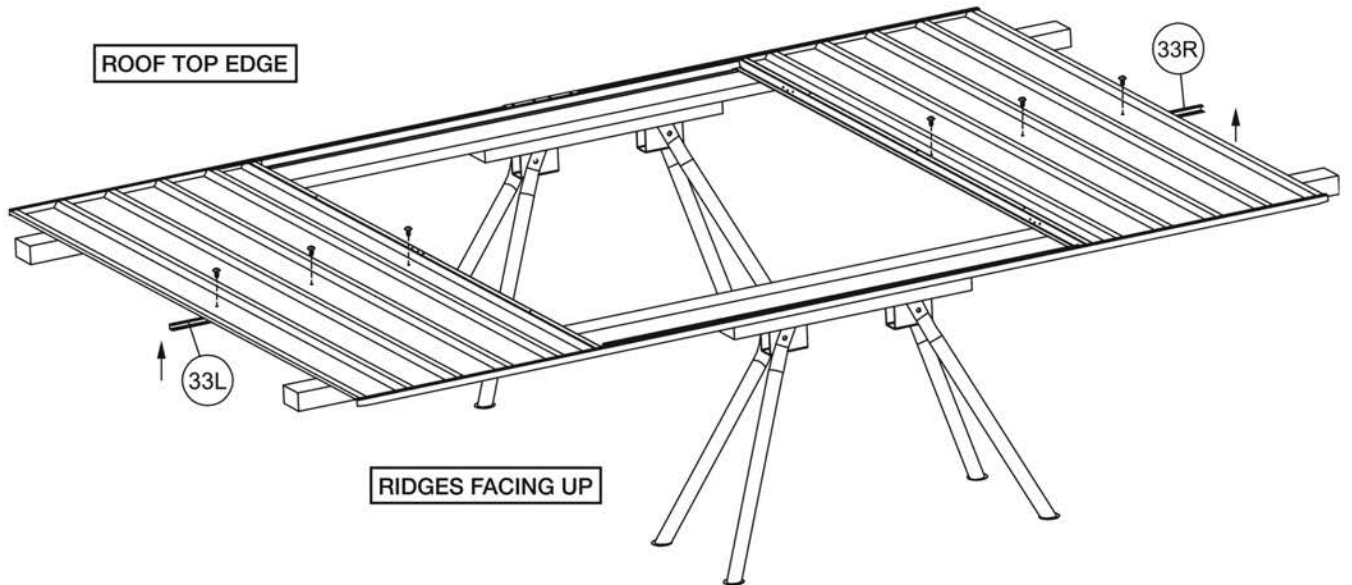

**Step 6:** Assemble the front doors

Place part D18R (door sheet) on the worktable. Fit 2 x part M26 and parts M24 and M25 (channels) to the door panel and fix with 3.0 x 10mm rivets as per the diagrams below. Please ensure channel M26 has the smaller lip facing outwards.

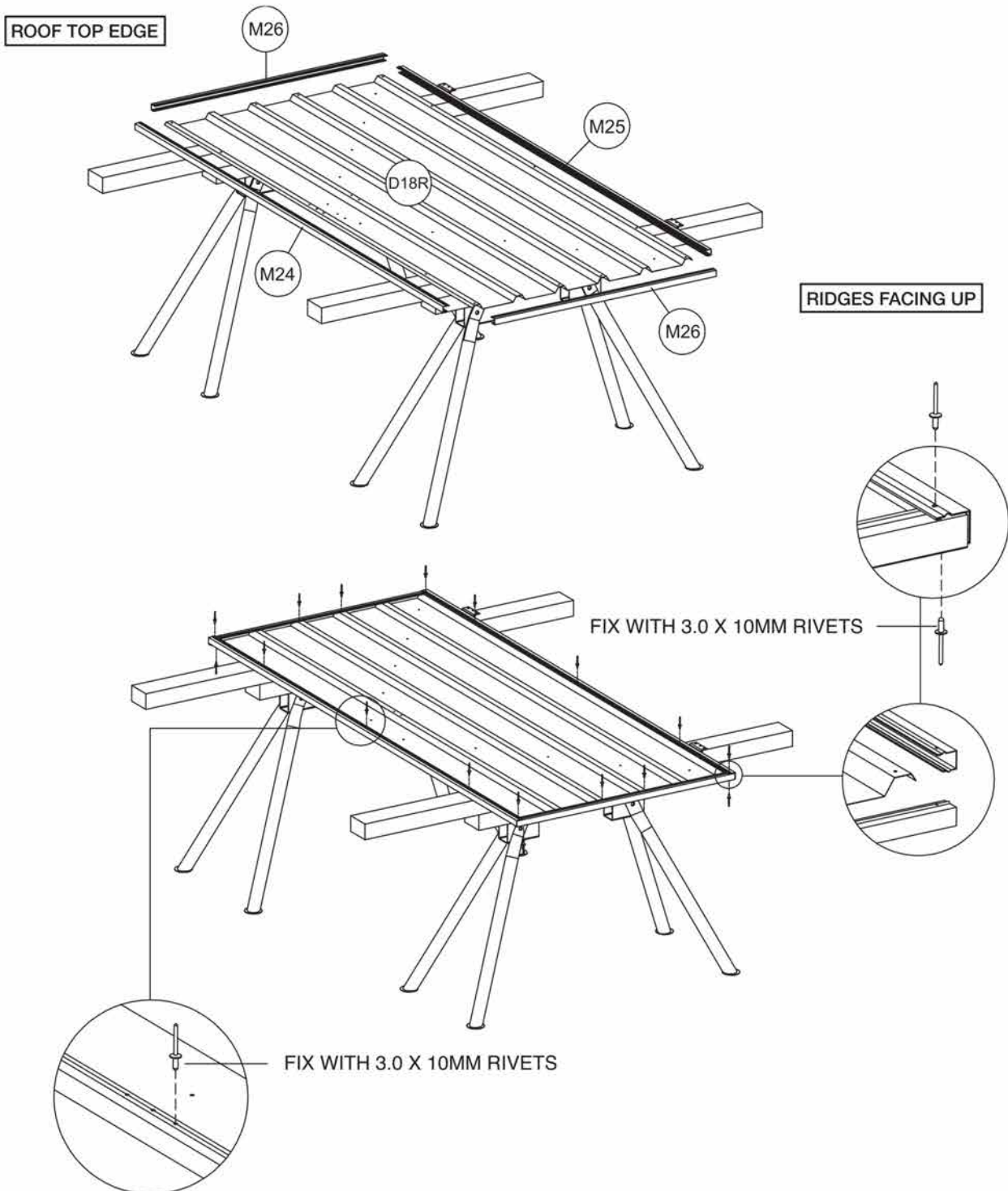

**Step 6:** Assemble the front doors (continued)

Now place D18L (door sheet) on the worktable. Fit parts M27, M28, M41 (channels) and part J20 (jamb) to the door panel and fix with 3.0 x 10mm rivets as per the diagrams below. Please ensure channels M27 and M28 have the smaller lip facing outwards.

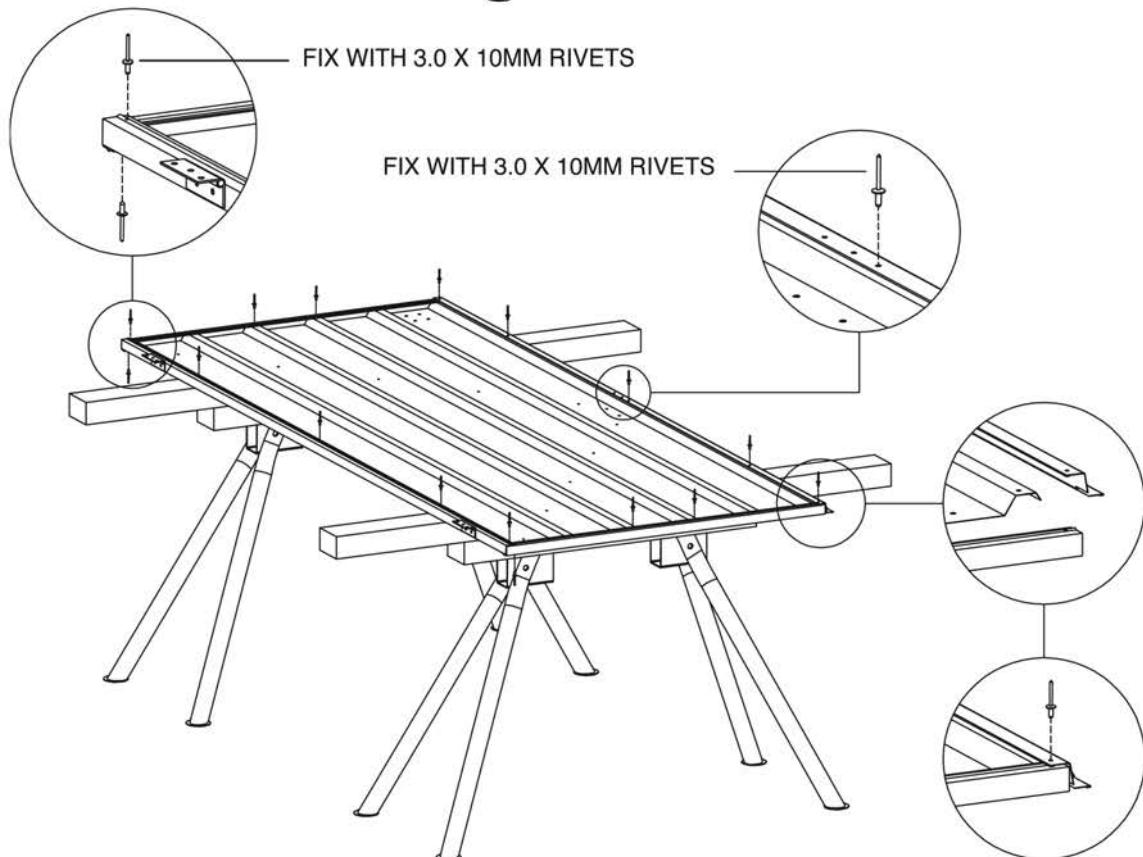
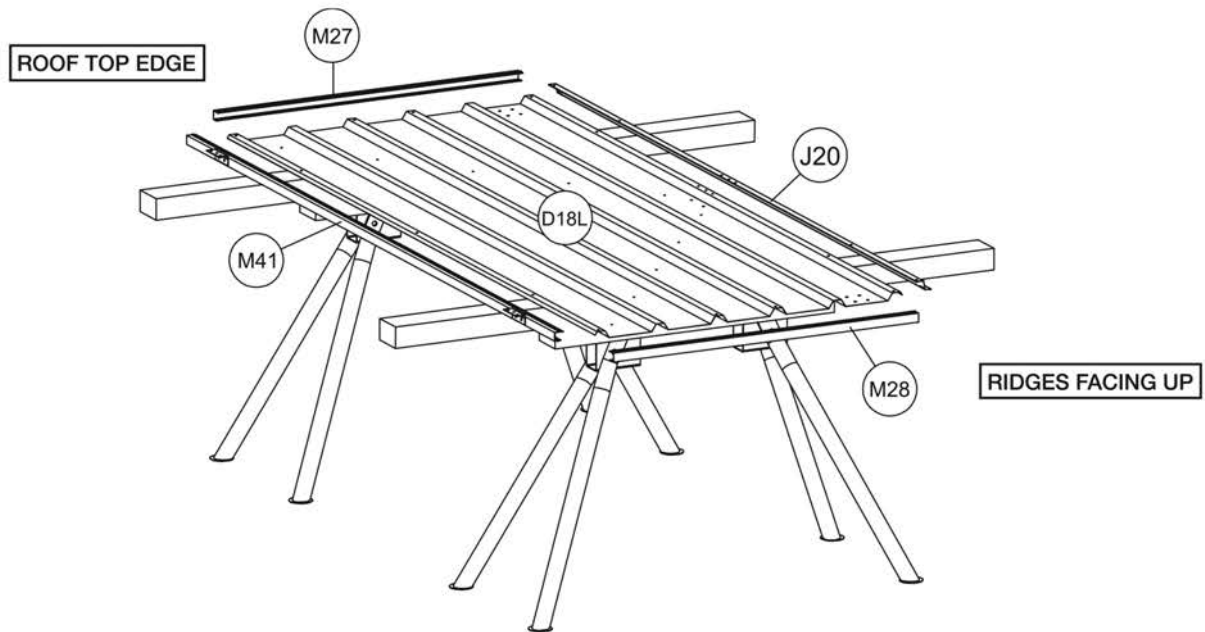

**Step 6:** Assemble the front doors (continued)

Once channels are fitted to both doors, align 2 x part U11 (brace) and part W (joining brace) with holes on the back of each door and position temporarily with some tape or simply hold in place.

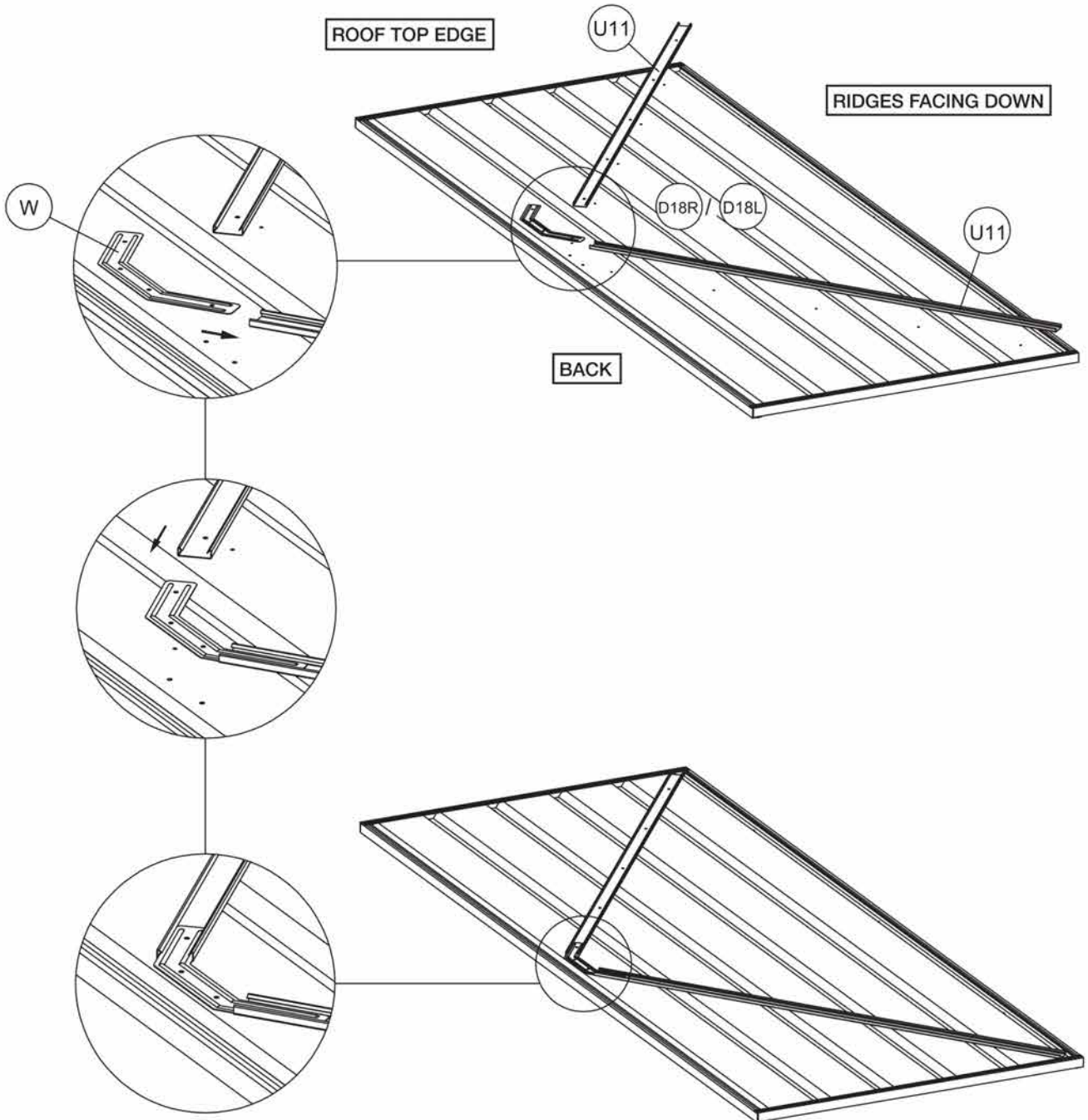

**Step 6:** Assemble the front doors (continued)

Turn door over with bracing still aligned with holes (make sure the ridges of the door are facing up) and fix the bracing with 3.0 x 10mm rivets through the front of the panel. Then turn door over and insert plastic stoppers at the ends of braces as shown below.

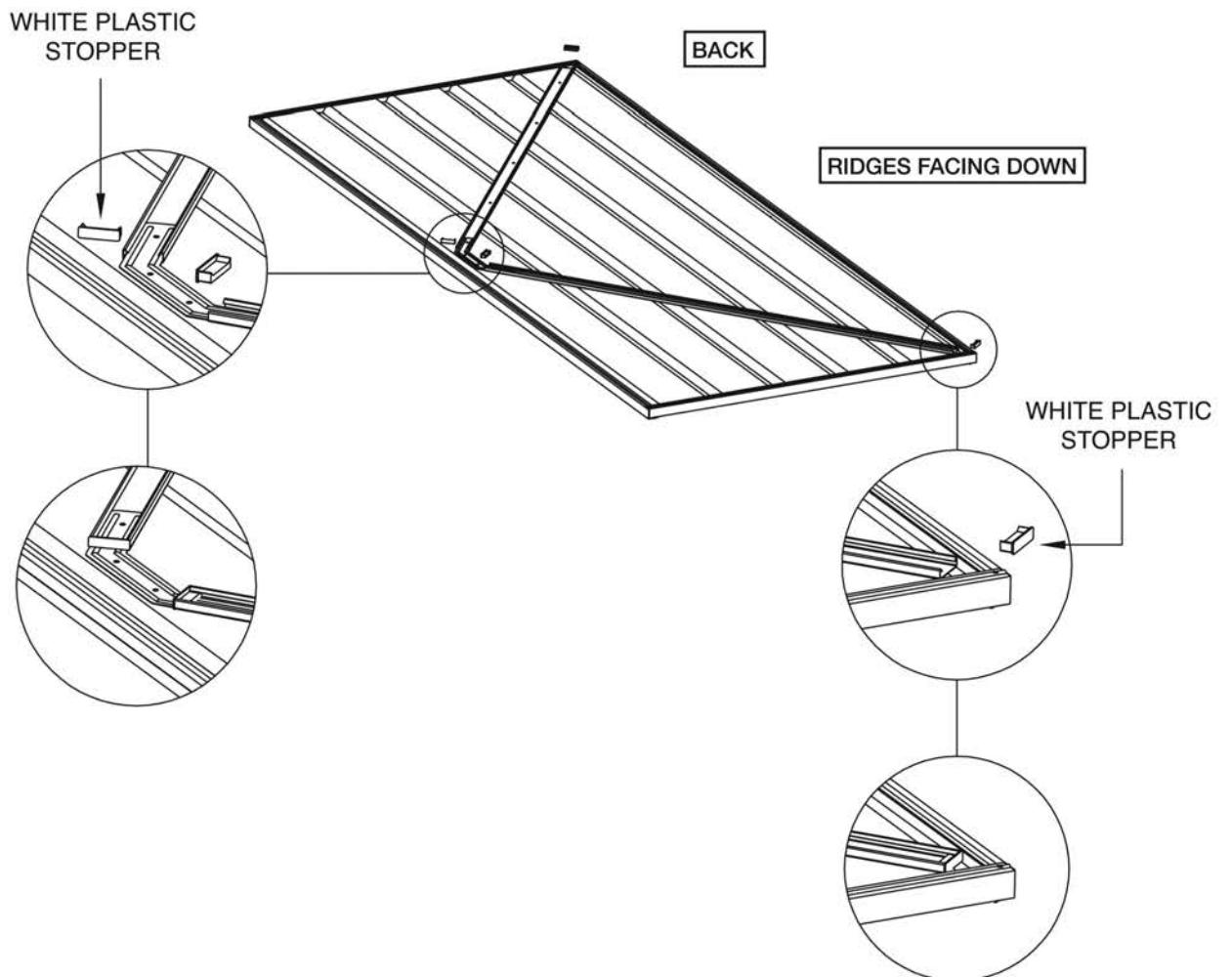
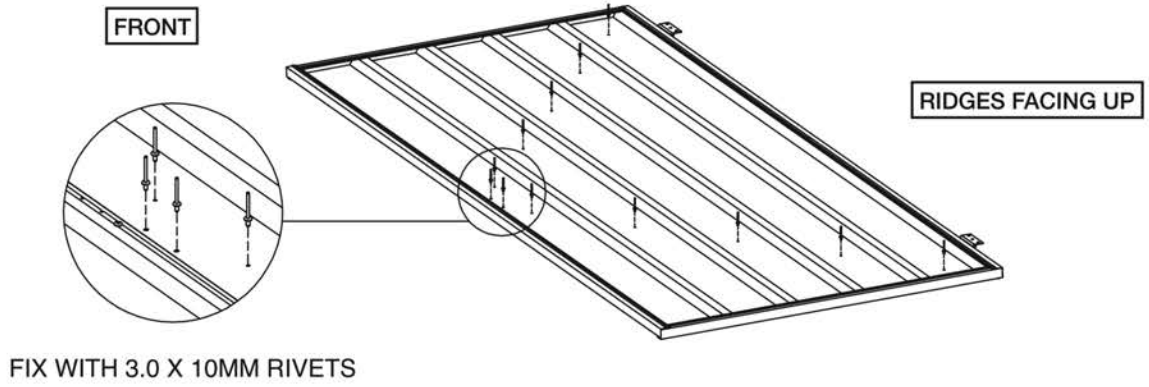

**Step 6:** Assemble the front doors (continued)

Fix parts 74 (barrel bolt) and 75 (barrel bolt plate) onto part D18L (door) using rivets. Ensure you rivet through the front of the panel with the Padbolt on the inside.

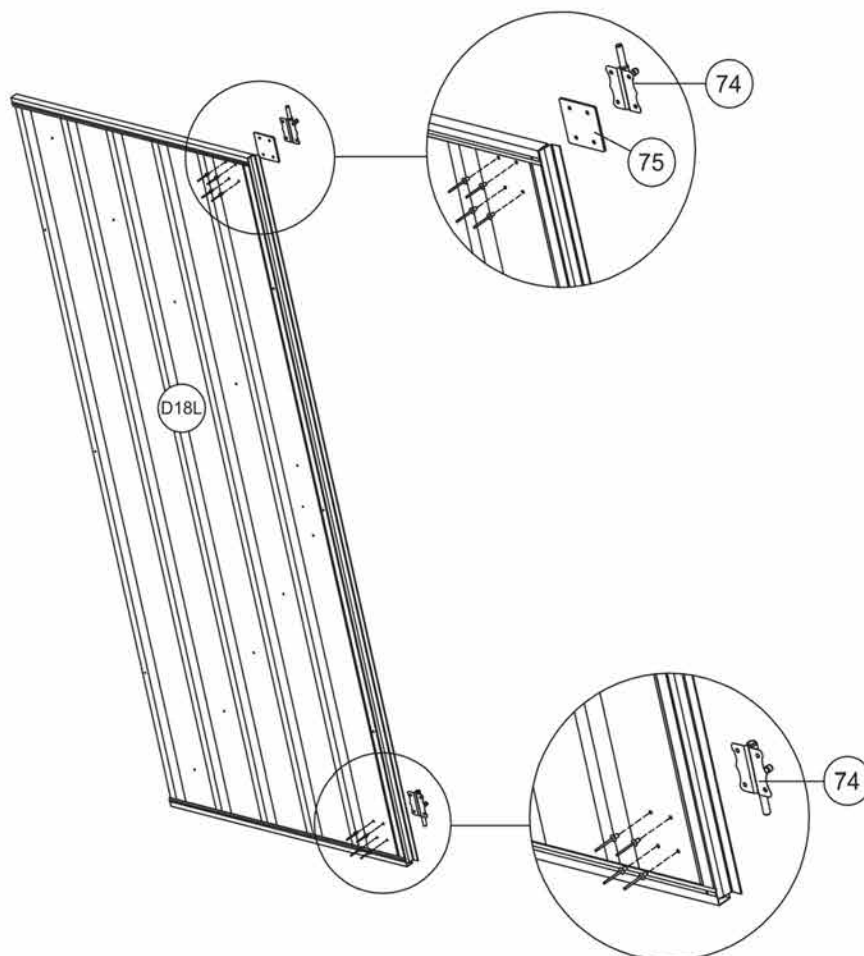

USE 4.0 X 10MM RIVETS

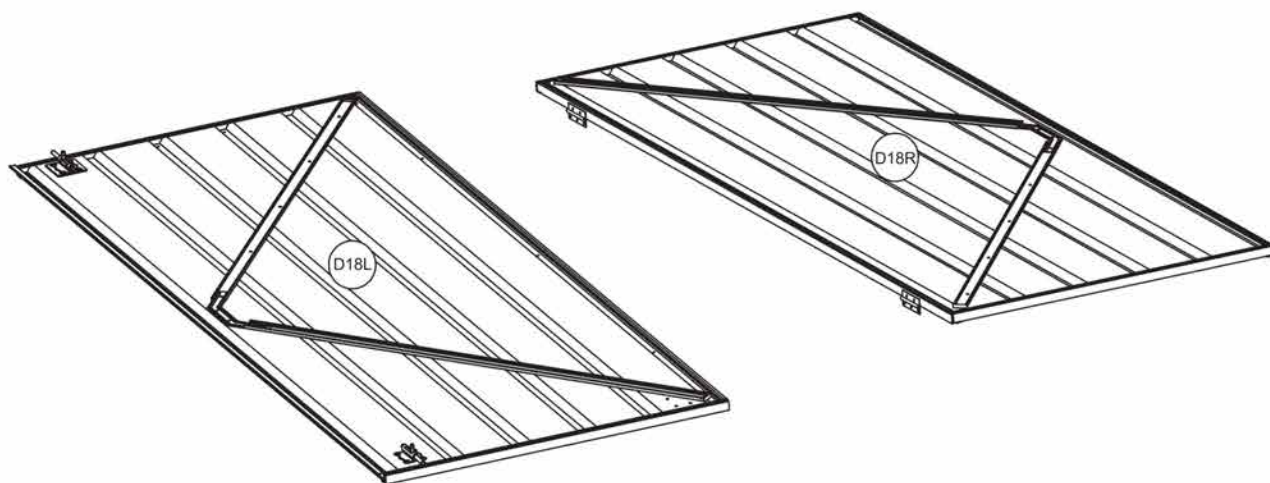

**Step 6:** Assemble the front doors (continued)

Fit parts D18L and D18R (assembled doors) to the front wall panel as per the diagram below. Use rivet gun and pre-drilled holes. Fix parts 70 (pad bolt) and 71 (keeper) to the doors using the pre-drilled holes and 16mm self-tapping screws (or the rivets provided - see diagrams A and B).

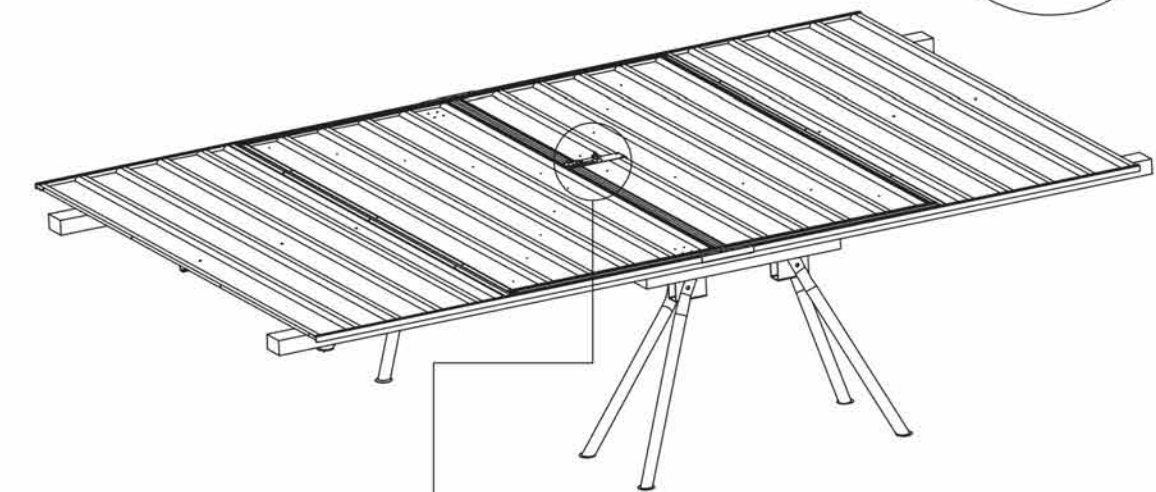
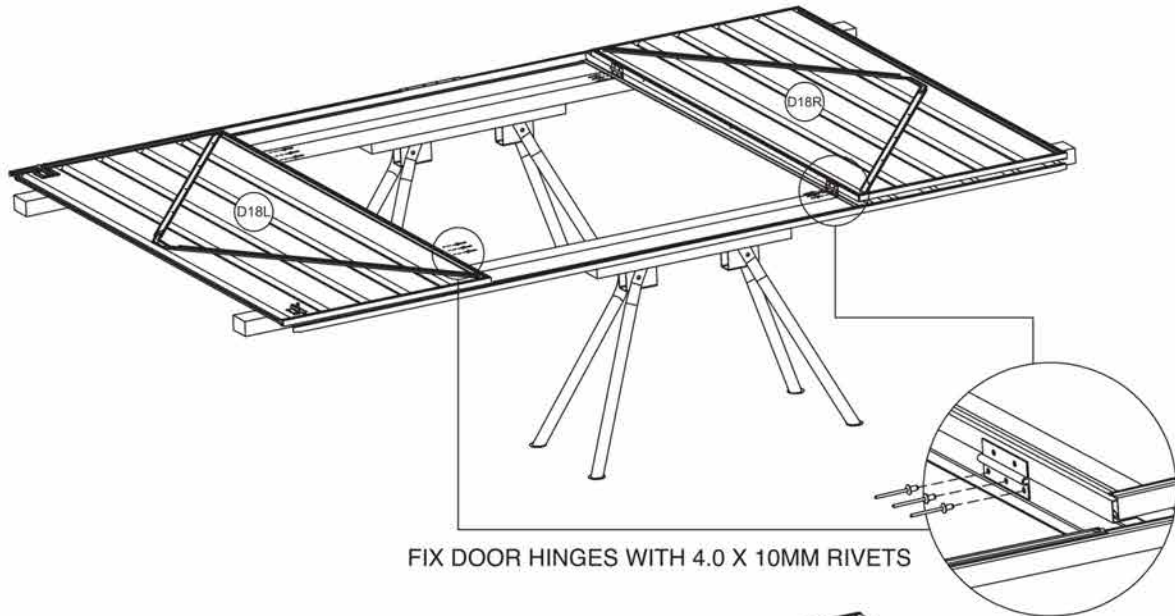

FIX PADBOLT KEEPER WITH 16mm SCREWS

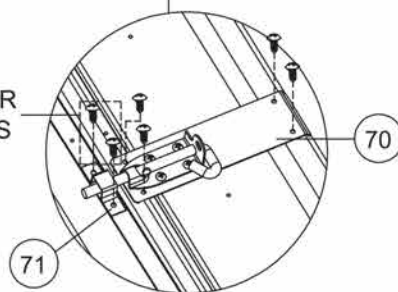

**A**

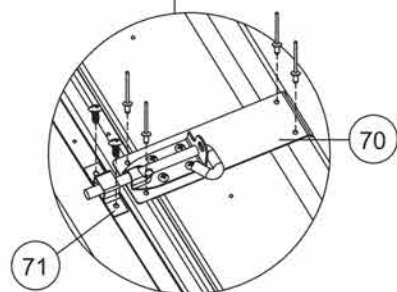

**B**

FIX PADBOLT WITH 3.0 X 10MM RIVETS



**Step 7: Fit the panels together**

Now fix the front, side and rear panels and 2 x part G7 and 2 x G8 (gables) together using the holes provided and self-tapping screws. Also attach 4 x part Z43 (corner brace) to each corner using the self-tapping screws provided.

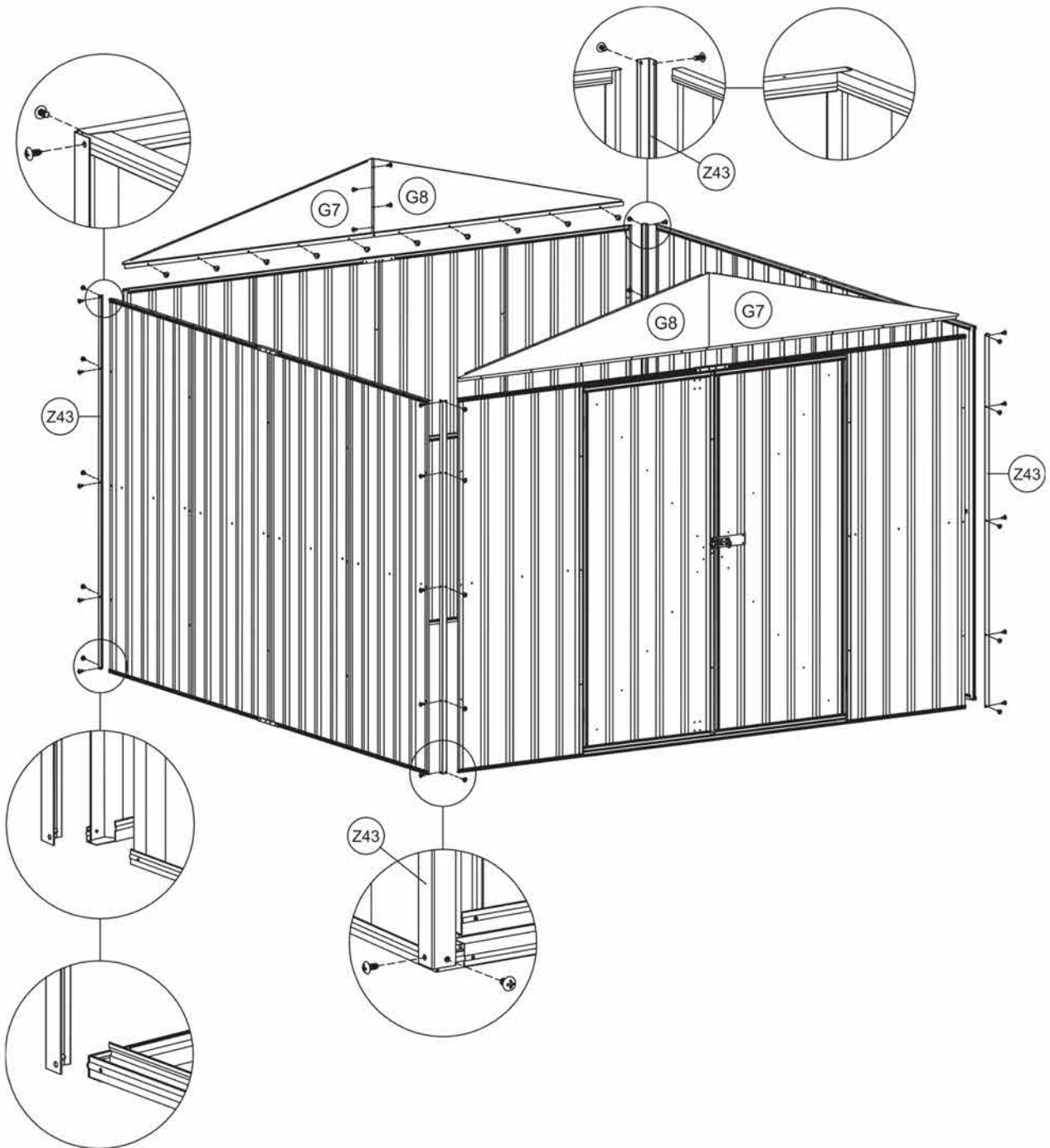

**Step 7: Fit the panels together (continued)**

Join 2 x part 73 (ridge beam) together at the end marked with red arrow using part 67 (ridge beam connector) as per the diagrams below. Put on 2 x part E4 (gable caps) and join them using part E3 (gable cap connector). Fix this structure using 16mm self-tapping screws.

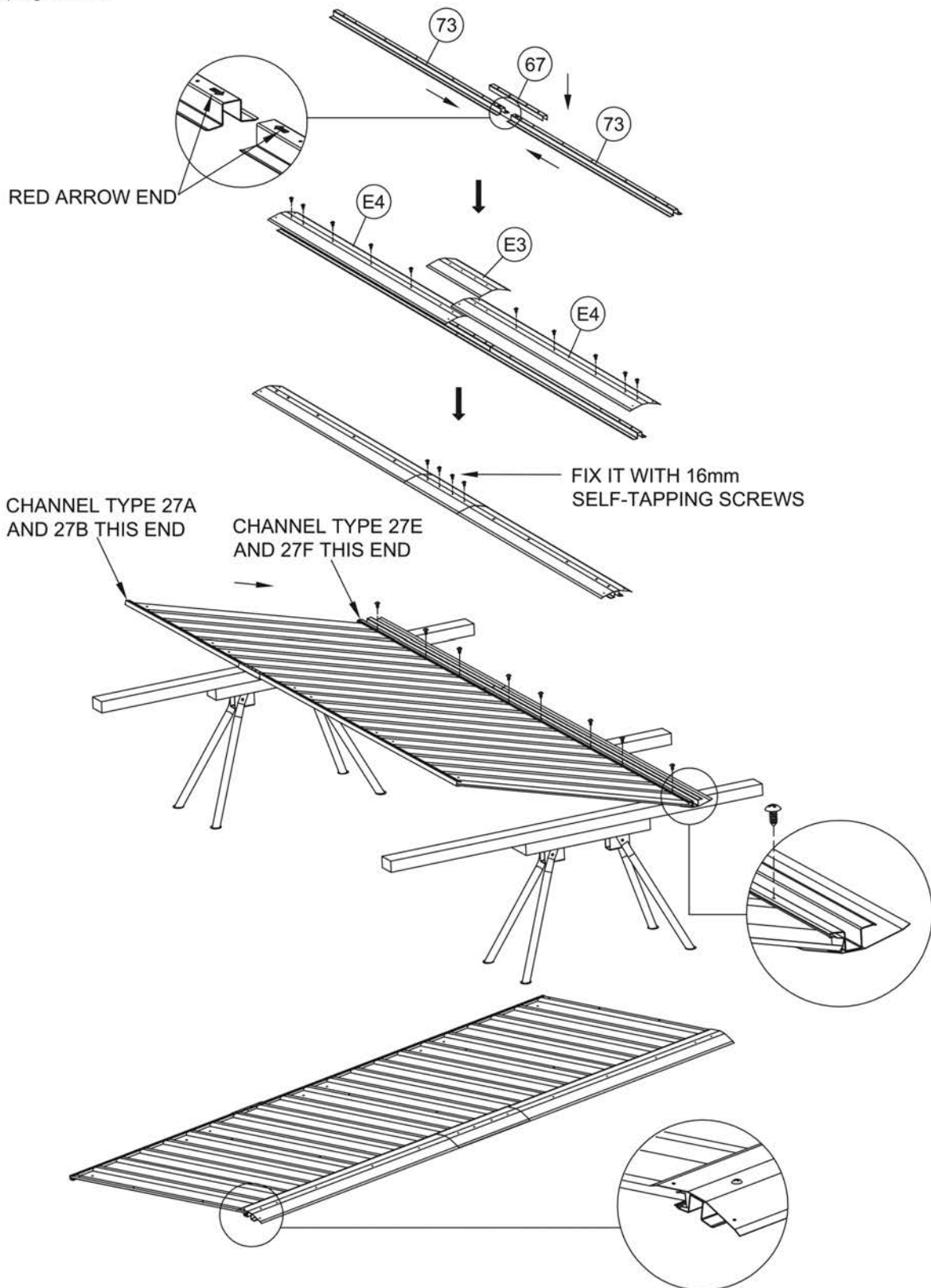

Slide the side of the roof panel with channels 27E and 27F into the ridge beam.

**Step 7: Fit the panels together (continued)**

Repeat the same step for the other assembled roof panel. Drill holes for roof brace using 3mm drill bit. Then fix the roof brace as per the below diagram. Join the sheeting and the gable using part L4 (lip) and then fix the 4 corners using 16mm self-tapping screws. (Do NOT fix central screw marked with a cross at this stage).

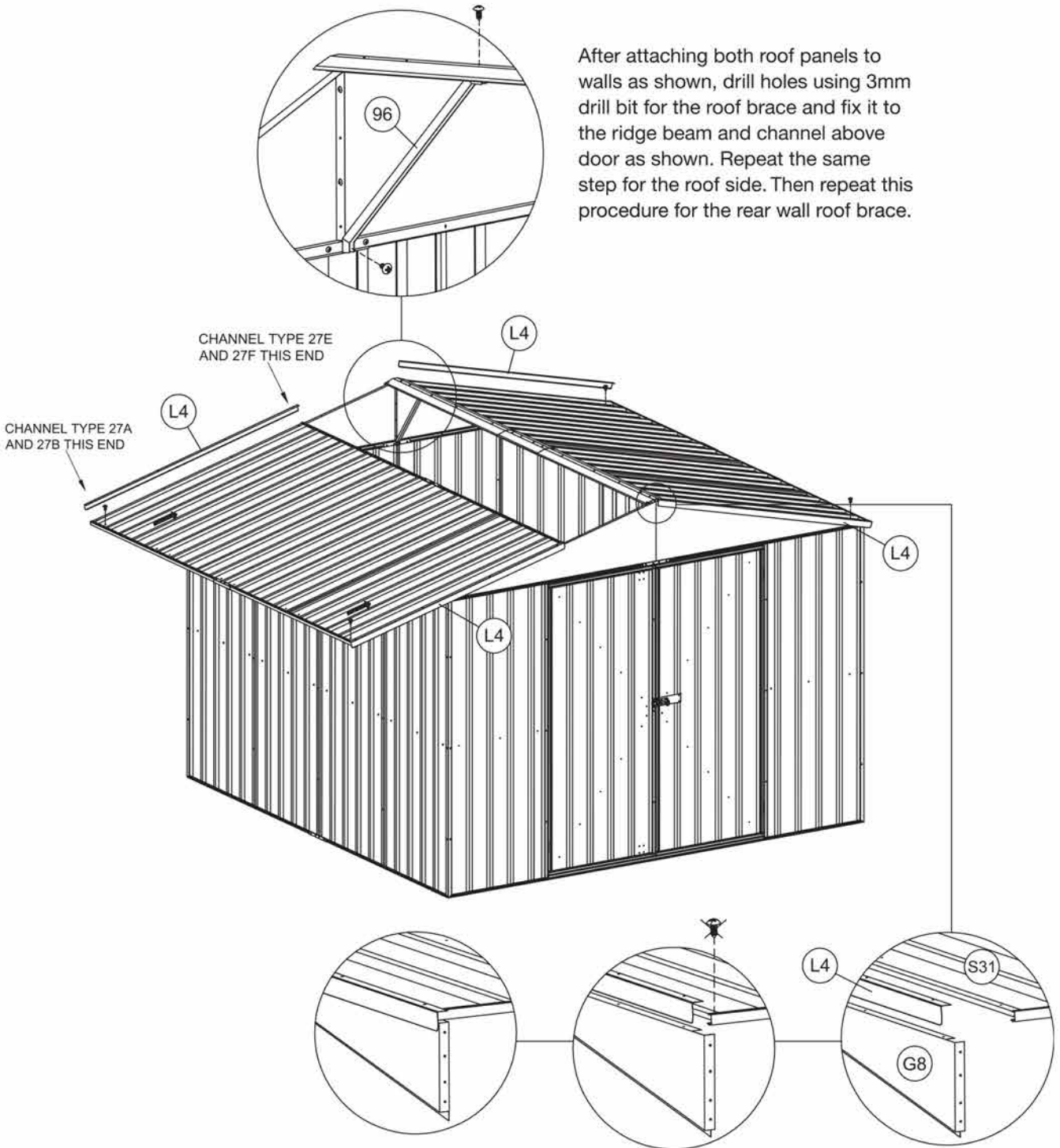

Attach 2 x part 95 (logo cap) and fix roof panels using 16mm self-tapping screws as per the diagrams below.

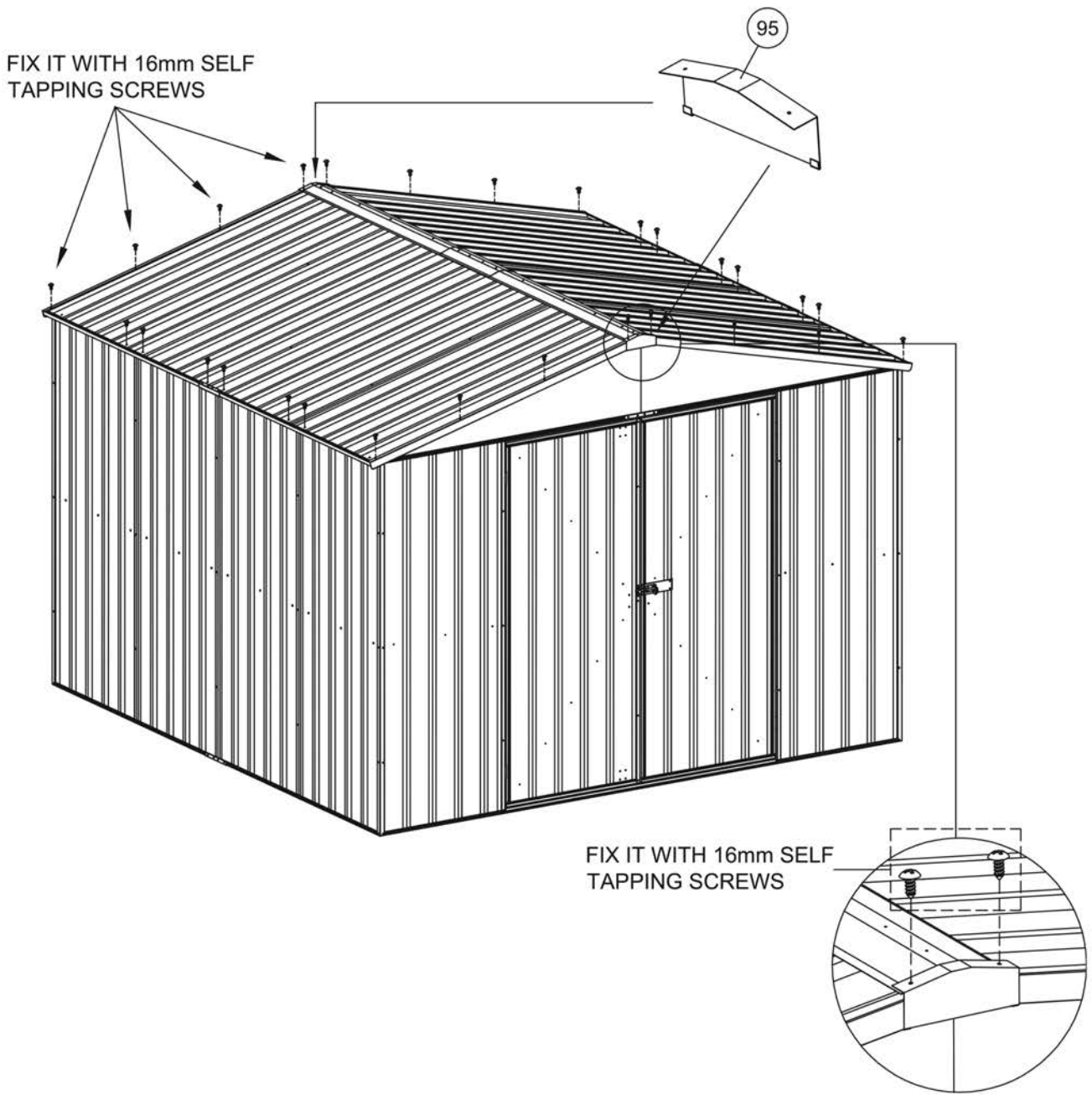

Now fit the bolt down kit as per the below diagram. Strengthen your mid wall brace by applying part 72 (mid wall brace bracket) to each corner if necessary. Align part 71 (keeper) with the barrel bolt on the door and fix to the bottom channel using self-tapping screws.

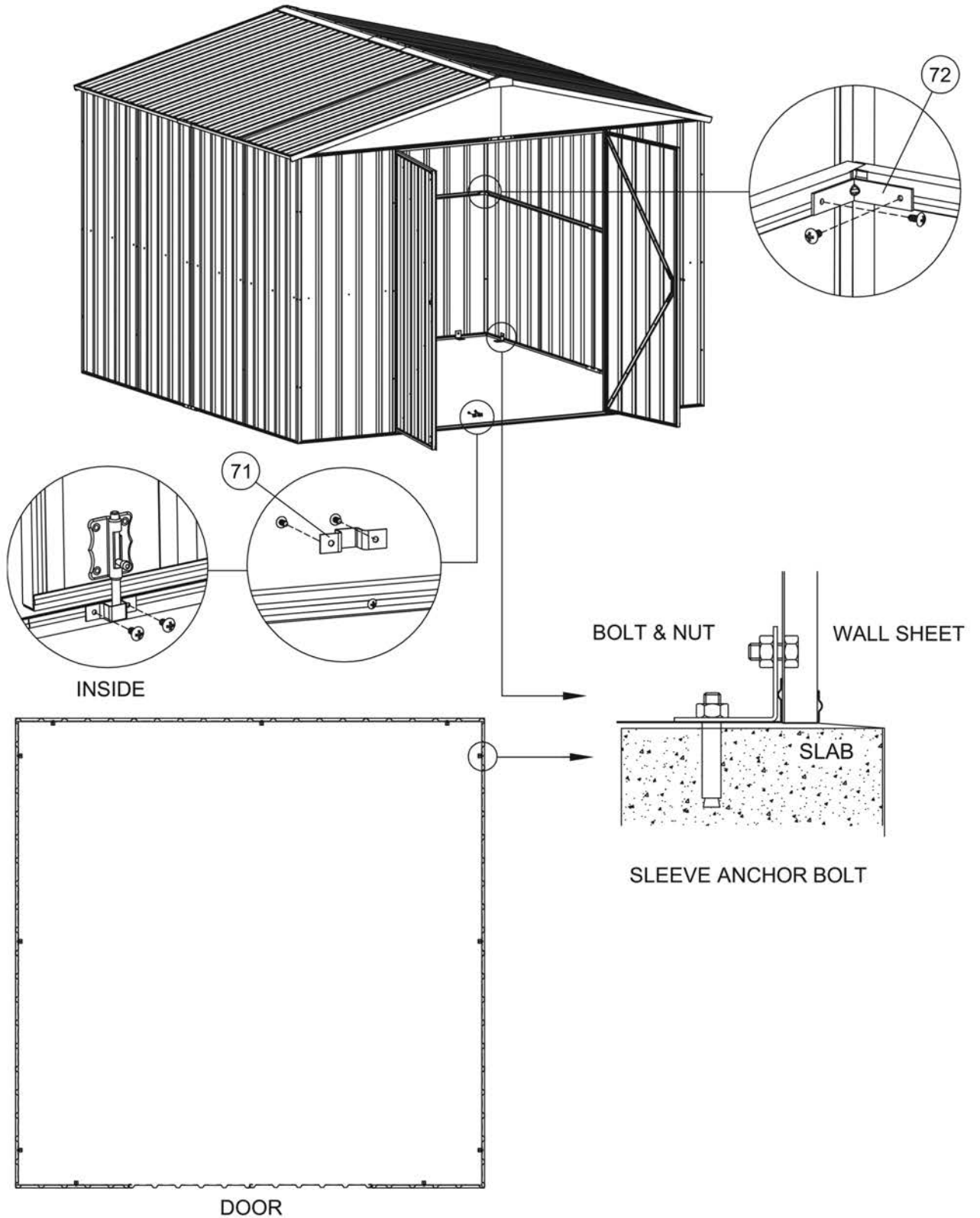

Apply channel safety cover L type to channel 33L and R type to channel 33R for safety. Also apply the self-tapper covers to the screw ends visible in walls on the inside of the shed.

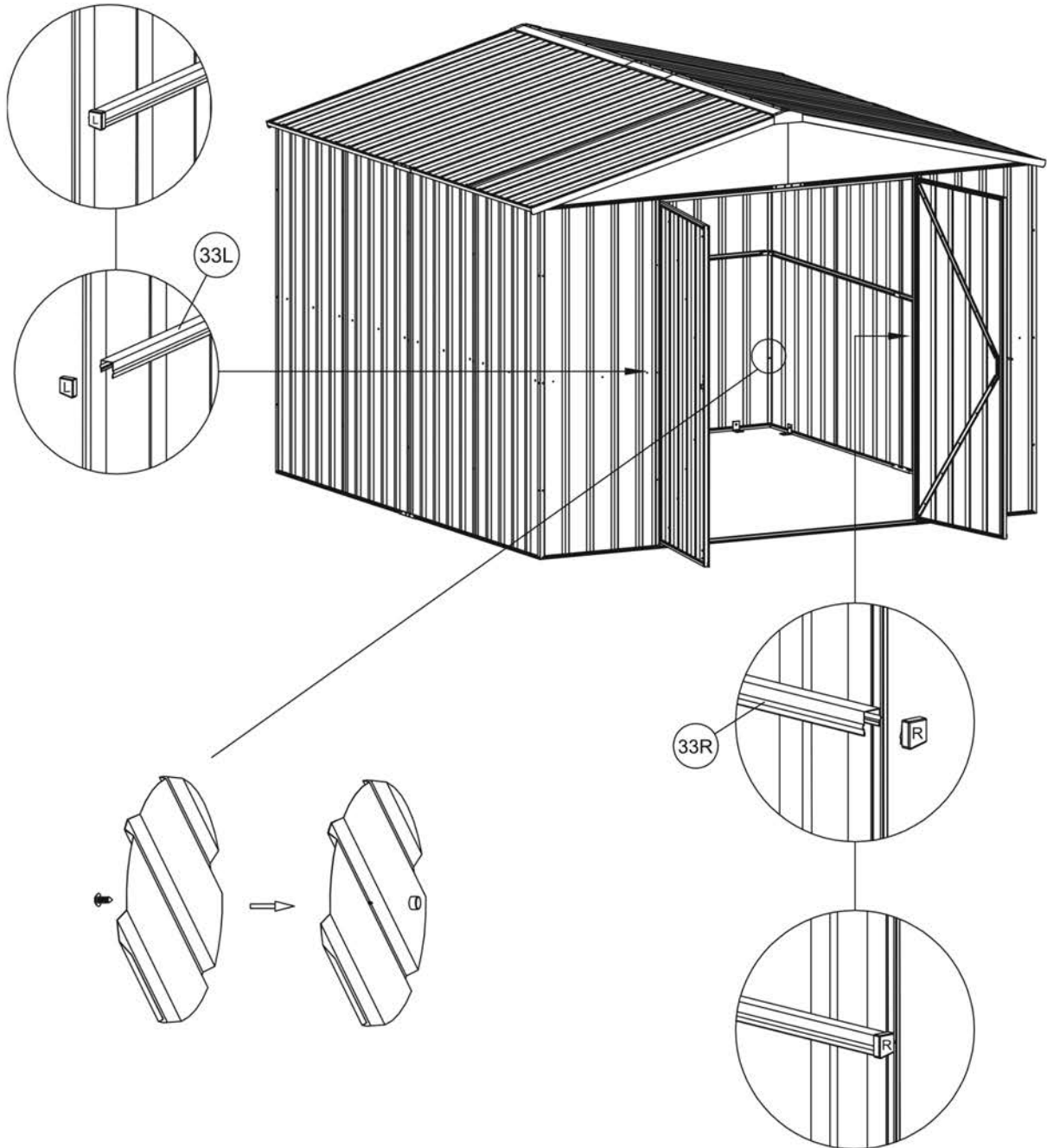

### **Environment Protection and Waste Protection and Electrical Equipment Regulations (WEEE)**

Recycle unwanted packaging materials. When this product is no longer required, or has reached the end of its useful life, please dispose of it in an environmentally friendly way. Drain any fluids (if applicable) into approved containers, in accordance with local waste regulations. It is our policy to continually improve products and we reserve the right to alter data, specifications and parts without prior notice. No liability is accepted for incorrect use of this product. Guarantee is 12 months from purchase date, proof of which is required for any claim.

**Note:** It is our policy to continually improve products and as such we reserve the right to alter data, specifications and component parts without prior notice.

**Important:** No Liability is accepted for incorrect use of this product.

**Warranty:** Guarantee is 12 months from purchase date, proof of which is required for any claim.

## **Dellonda Limited**

Kempson Way, Suffolk Business Park, Bury St Edmunds, Suffolk. IP32 7AR



01284 757575



support@dellonda.co.uk



www.dellonda.co.uk