



Dellonda 4 Burner Gas BBQ, Burner, Piezo Ignition, Thermometer, Shelves, Castor Wheels



Model No. DG17

Thank you for purchasing a Dellonda product. Manufactured to a high standard, this product will, if used according to these instructions, and properly maintained, give you years of trouble free performance.

Important Information

Please read these instructions carefully. Note the safe operational requirements, warnings & cautions. Use the product correctly and with care for the purpose for which it is intended. Failure to do so may cause damage and/or personal injury and will invalidate the warranty. Keep these instructions safe for future use.



Refer to
instruction
manual



Wear
Gloves



Warning:
Hot
Surface

Specification

No. of burners: 4 +1

Cooking area W x D: 700 x 420mm

Warming rack W x D: 700 x 120mm

Ignition: Piezo

Power: 14.5kW (3kW per burner. 2.5kW side burner)

Dellonda Limited Kempson Way, Suffolk Business Park, Bury St Edmunds, Suffolk. IP32 7AR www.dellonda.co.uk			Product Name: Outdoor Gas Grill Pin Number: 0063CN7292		
Country of Destination	Appliance Category	Gas and Supply Pressure	Main Burner	Side Burner	Appliance Name
			Injector Size Ø	Injector Size Ø	DG17
GB	13+(28-30/37)	Butane (G30) 28-30 mbar	0.86mm	0.76mm	Total Nominal Heat Inputs (Hs) 14.5kW (1054g/h)
		Propane (G31) 37 mbar	0.86mm	0.76mm	14.5kW (1034g/h)
Outdoor use only. Read the instructions before using the appliance. The gas cylinder should not be placed inside BBQ. Warning: Accessible parts may be very hot. Keep young children away.					

About the Product

Gas barbecue with four stainless steel burners. Built-in thermometer enables you to easily keep track of your cooking temperature. Piezo ignition ensures a safe and easy start-up every time. High quality cast iron cooking grates with a matt enamel coating. Features side burner, perfect for cooking and preparing sides/sauces. Features side shelf giving extra room for preparation. Warming rack frees up space on the grill whilst keeping your food warm after cooking. Supplied with regulator and hose assembly for use with propane patio gas bottles. Features four universal castor wheels for easy manoeuvrability. Product Size (W x D x H): 1330 x 570 x 1140mm. Dellonda BBQ Cover Model No. DG25 (supplied separately) is a perfect fit for this BBQ.

Safety Instructions

• GENERAL SAFETY

- **WARNING!** The warnings, cautions and instructions in this manual cannot cover all possible conditions and situations that may occur. It must be understood by the operator that common sense and caution are factors which cannot be built into this product, but must be applied by the operator.
- **WARNING!** Hazardous fire or explosion may result if instructions are ignored. Read instructions before use.
- **WARNING!** Never use a flame to do the leak test and ensure no naked flames are nearby when doing the leakage test.
- **WARNING!** Accessible parts may be very hot. Keep young children and pets away. Take special care when children and elderly are present.
- **WARNING!** If you smell gas: turn off the gas supply at the cylinder, extinguish all naked flames, DO NOT operate any electrical appliances, check for leaks as detailed in this manual. If odour persists, contact your Dellonda stockist.
- **WARNING!** Any modification to this appliance may be dangerous and is absolutely not permitted.
- **WARNING!** The hood must always be open when lighting the burner.
- Read the instructions carefully before assembly and retain this manual for future reference.
- Turn off the gas supply at the gas bottle after use.
- Use outdoors only, stand on a level surface, remember hot fat may drip out of the drip tray.
- Handle the hot barbecue with the help of oven gloves.
- The barbecue should be cleaned on a regular basis. Take care not to enlarge burner ports or orifice openings when cleaning the burner or valves.
- Connect the regulator and hose onto the gas cylinder, close all the valves by turning the control knobs to the "OFF" (fully clockwise) position.
- Always do the gas leak check before you use the barbecue and after a cylinder change. Test the leakage on all the connections where gas passes by.
- **GAS LEAK CHECK** Put soapy water on all the connections where the gas reaches. Open the gas cylinder valve and regulator. If bubbles are seen, tighten the connection. If bubbles are still seen, close all valves, turn off the regulator and contact your Dellonda for help. **Never use the barbecue with a leak.**
- The gas cylinder can only be changed by a competent person.
- Use oven gloves and sturdy long handled barbecue tools when cooking on the grill.
- Be prepared if an accident or fire should occur. Know where your first aid kit and fire extinguishers are and how to use them correctly.
- Keep the gas supply hose away from any heated surfaces.
- Ensure the appliance has completely cooled before storing.
- Cylinders must be stored outdoors, upright and out of reach of children. Protect cylinder from high temperatures and replace the plastic port cap.
- This gas barbecue is designed for outside use only.
- **DO NOT** use in high winds.
- **DO NOT** move the barbecue whilst it is in operation.
- **DO NOT** operate if there is a gas leak.
- **DO NOT** attempt to disconnect any gas fitting if your barbecue is being used, including the gas hose and regulator.
- **DO NOT** leave unattended, from being lit to fully cooled.
- **DO NOT** use this barbecue in a garage or any enclosed area. Keep the surrounding area clear, at least 1.0m from any combustible materials and 0.5m from a brick wall.
- **DO NOT** attempt any unauthorised interference of the main controls on this barbecue, i.e. gas taps, injectors, valve etc.
- **DO NOT** attempt to use charcoal in this barbecue.
- **DO NOT** position on a surface that may be damaged by hot fat or heat.
- **DO NOT** store petrol or other flammable vapours or liquids in the vicinity of use.
- **NEVER light a gas grill with petrol or comparable fluids.**
- **NEVER** store a spare gas bottle or an empty/disconnected bottle near or under the barbecue or near any other ignition or heat source.

- Adequate ventilation is vital for combustion and efficiency of performance of the barbecue. This will ensure the safety of the user and other people in the vicinity of the area where the appliance is being used.
- **NEVER** use in any enclosed covered area.

Contents

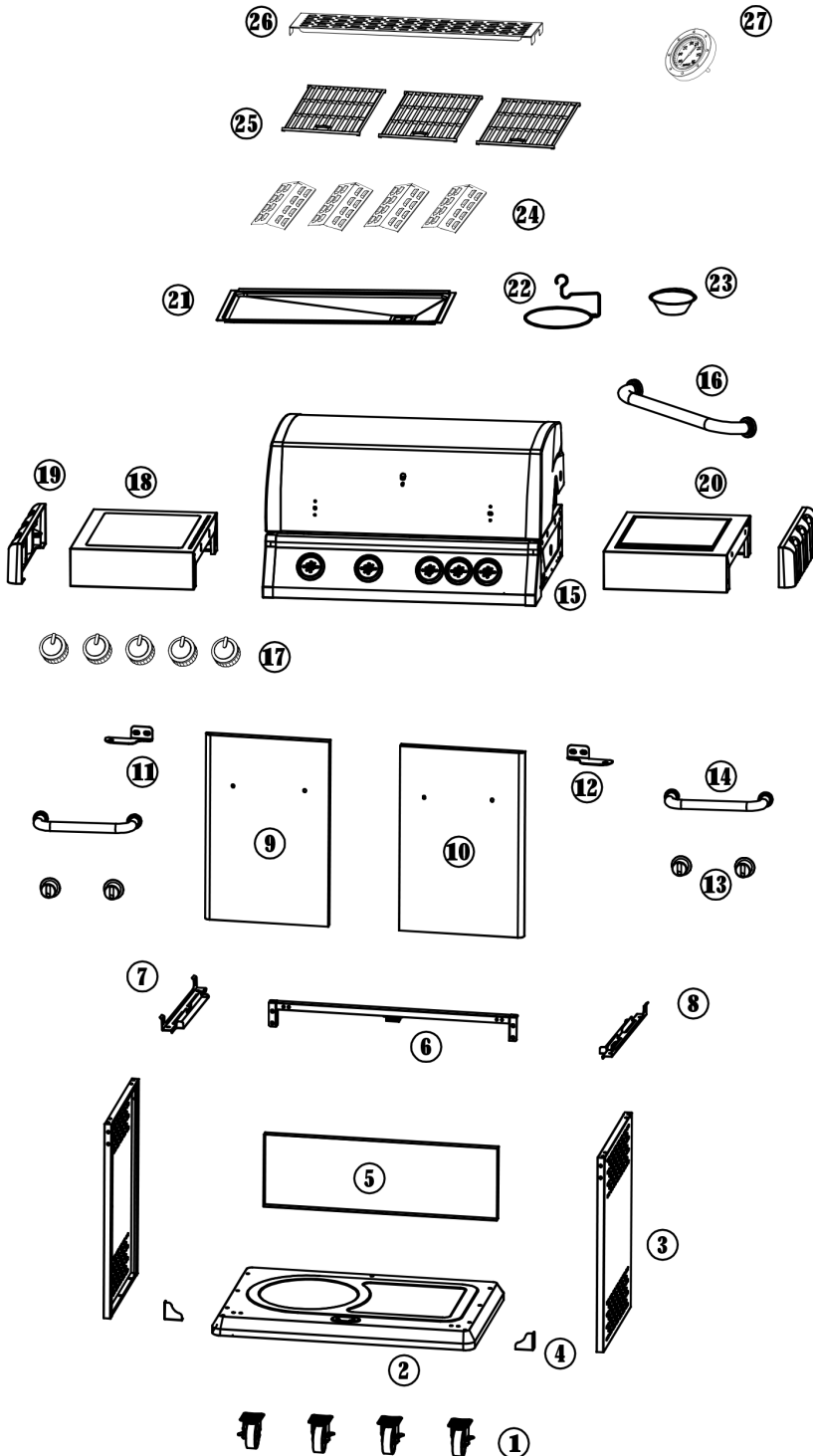
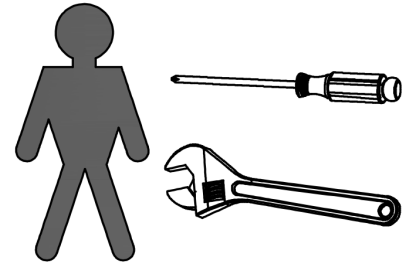
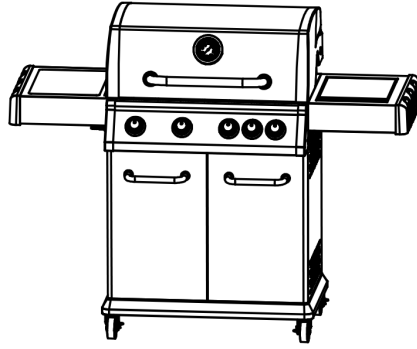

① *4	② *1	③ *2
④ *2	⑤ *1	⑥ *1
⑦ *1(L)	⑧ *1(R)	⑨ *1(L)
⑩ *1(R)	⑪ *1(L)	⑫ *1(R)
⑬ *4	⑭ *2	⑮ *1
⑯ *2	⑰ *5	⑱ *1
⑲ *2	⑳ *1	㉑ *1
㉒ *1	㉓ *1	㉔ *4
㉕ *3	㉖ *1	㉗ *1
A M5*10-49	B *4	C M4*8-2
D M6*15-6	E *1	F M5-10*10
G M4-8*4	H M5*16-8	I M5-6*8
J *1	K ϕ 28-2*1	

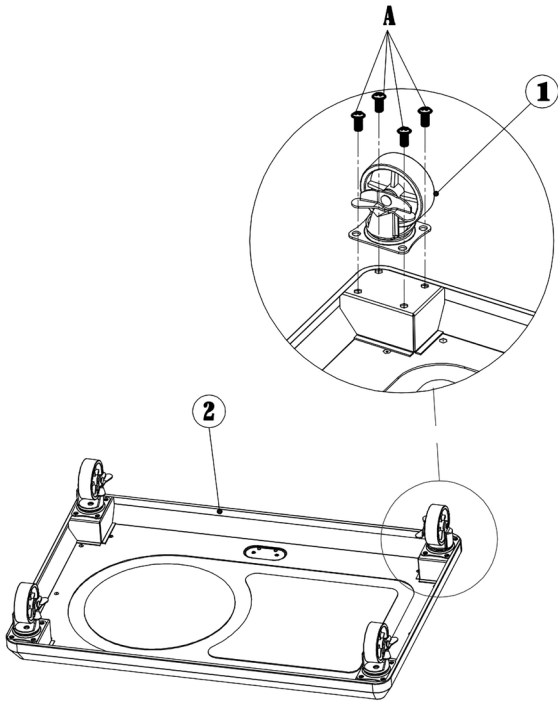
1

A

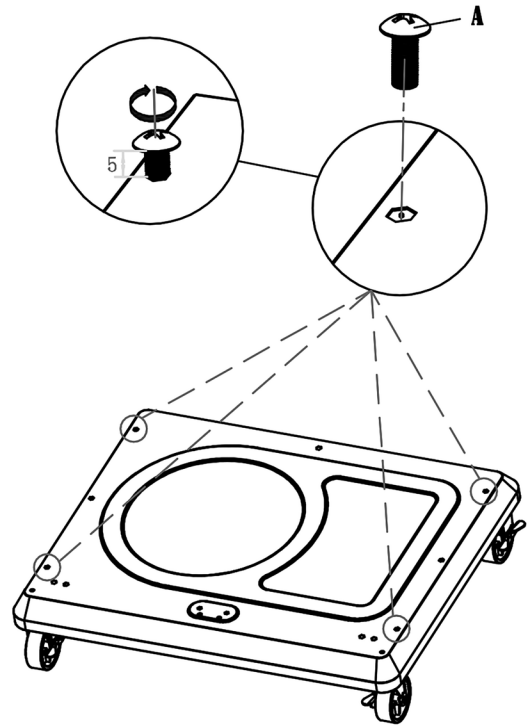
**16PCS****2**

A

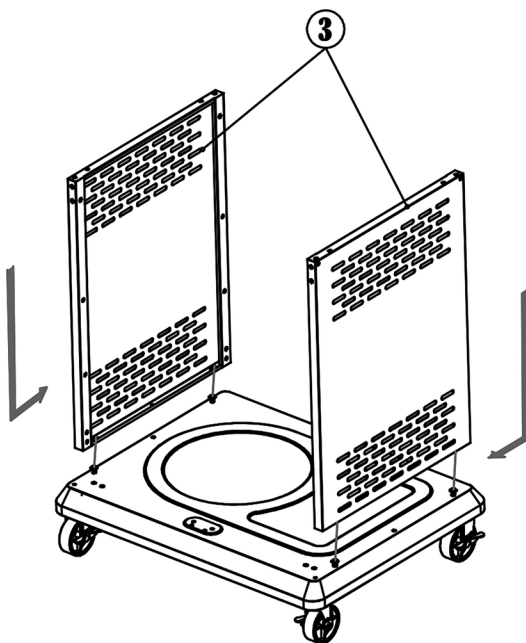
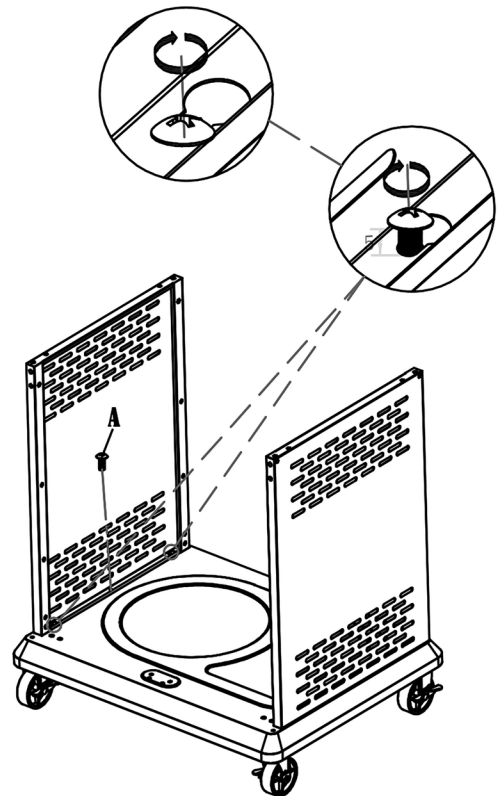
**4PCS****3****4**

A

**2PCS**

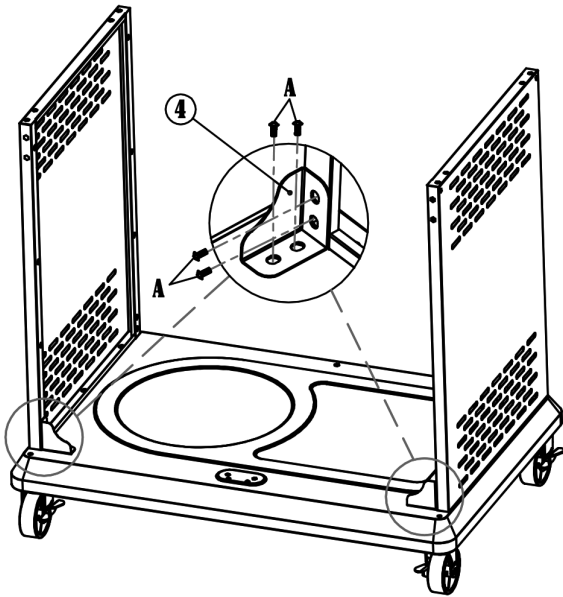
5

A		8PCS
---	---	------

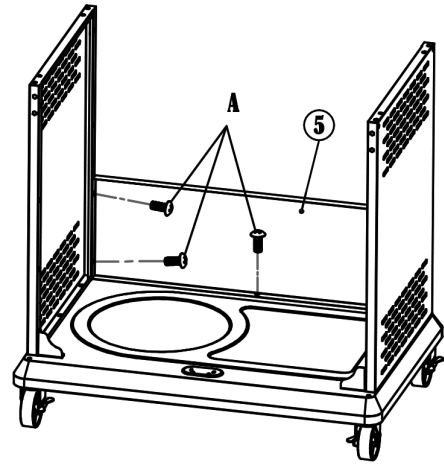
6

A		5PCS
---	---	------

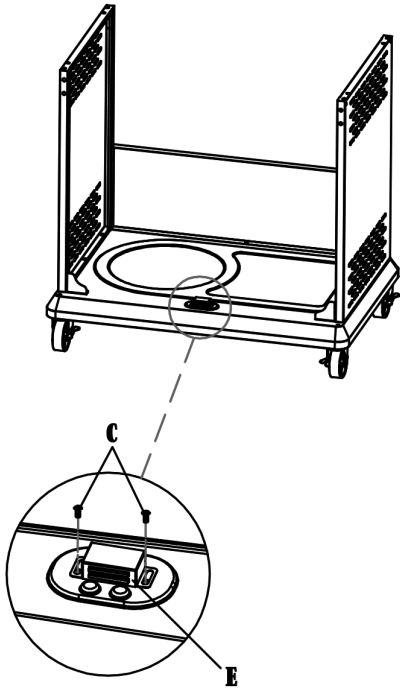
7

C		2PCS
---	---	------

E		1PC
---	---	-----

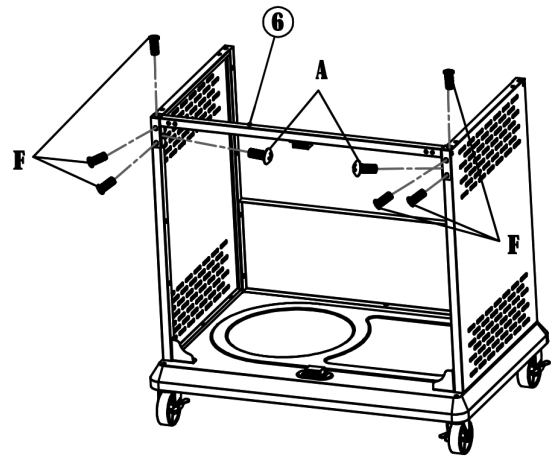
8

A		2PCS
---	---	------

F		6PCS
---	---	------

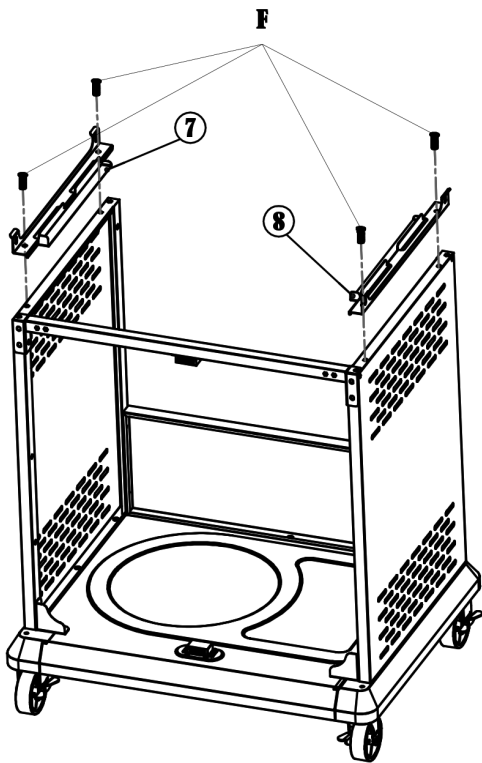
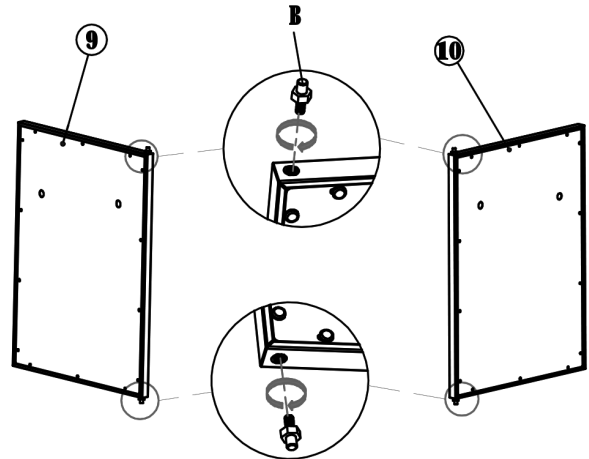
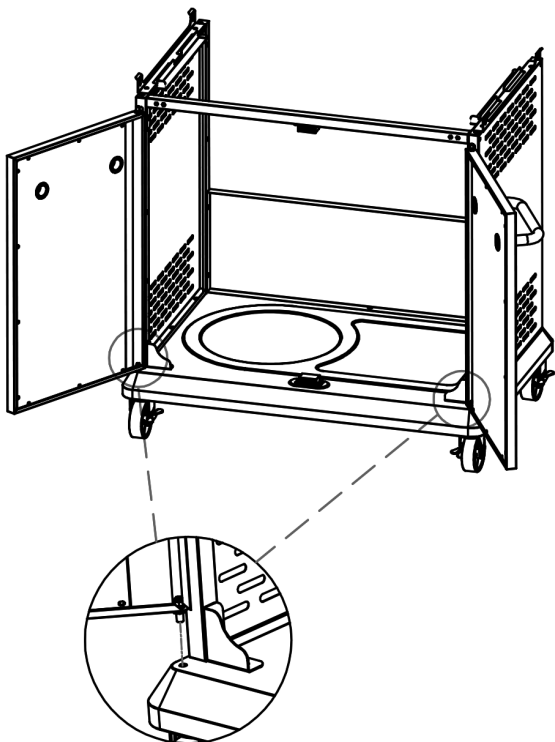
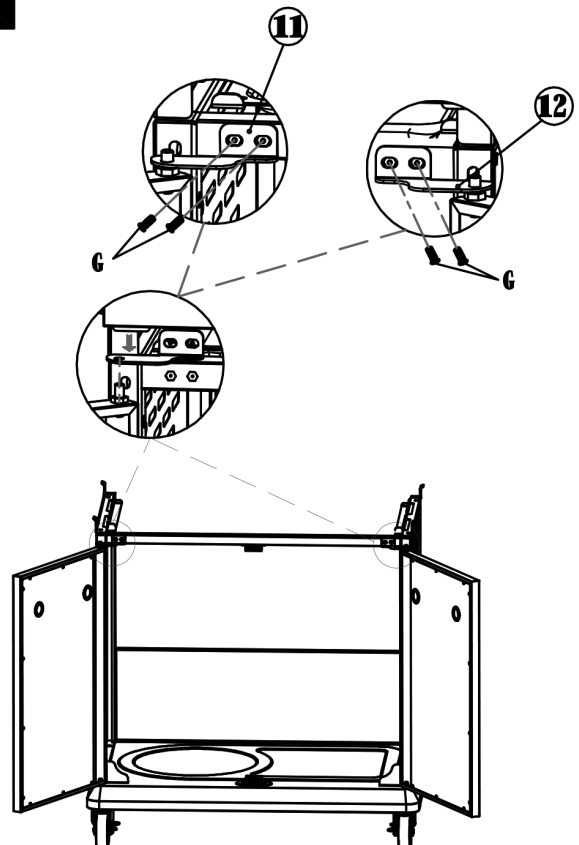
9**F****4PCS****10****B****4PCS****11****12****G****4PCS**

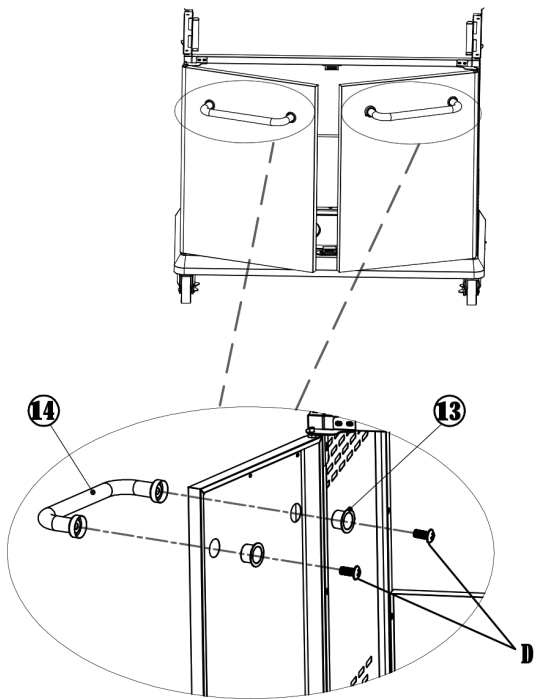
13

D

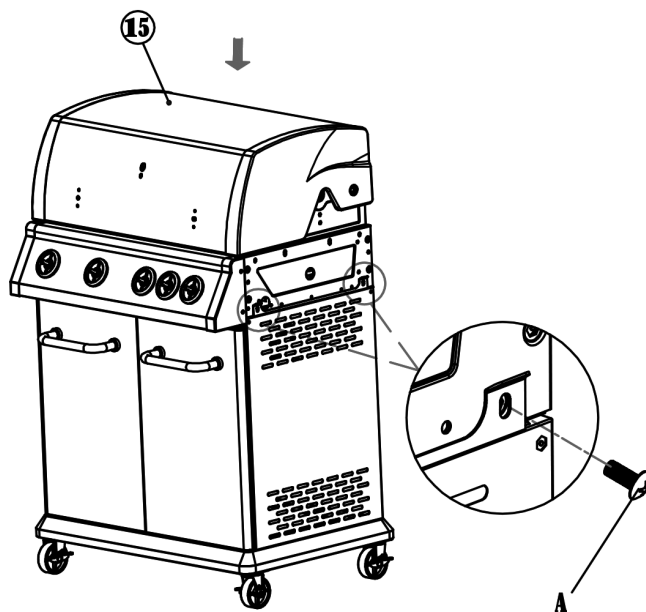

4PCS

14

A

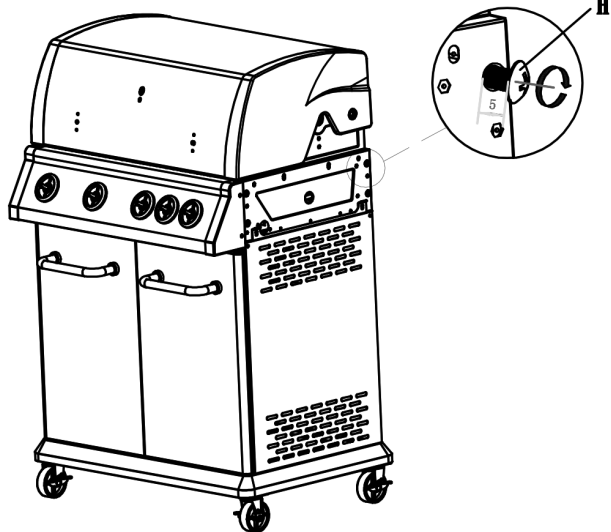

4PCS

15

H

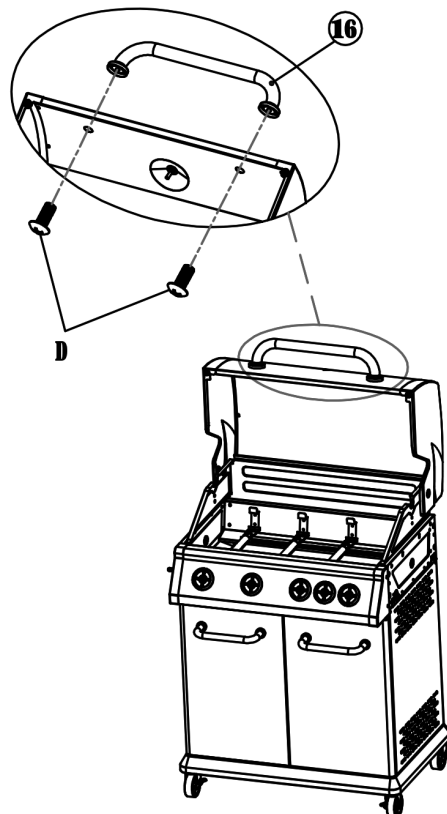

4PCS

16

D

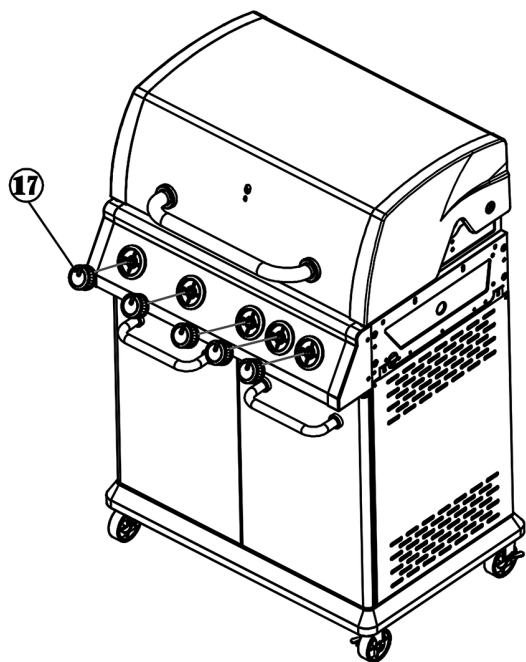
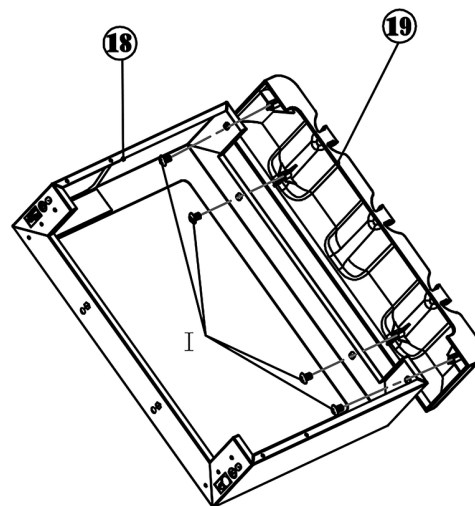

2PCS

17**18**

I

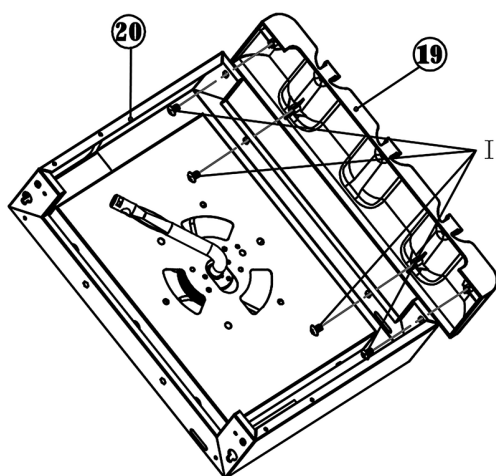

4PCS

19

I

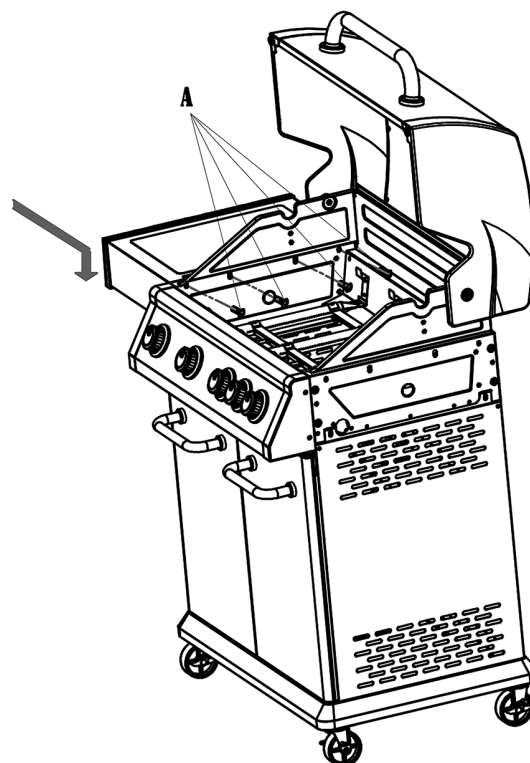

4PCS

20

A



4PCS

21

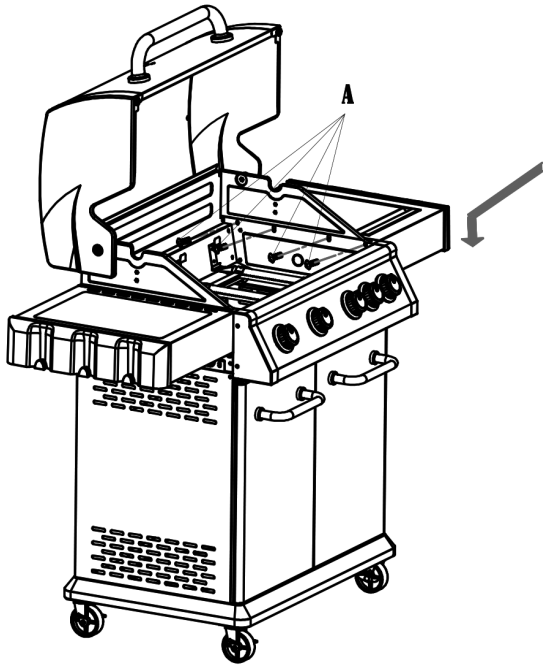

A		4PCS
---	---	------

22

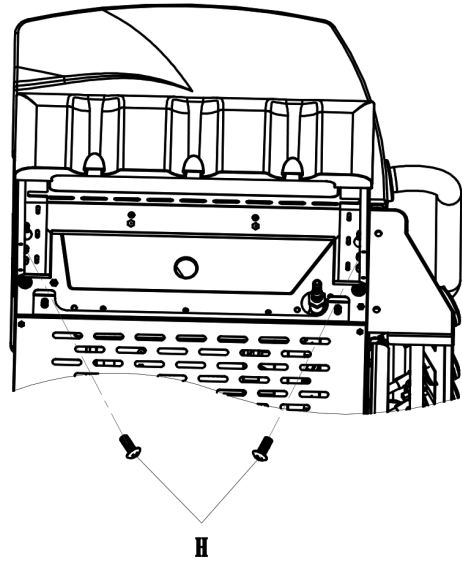

H		4PCS
---	---	------

23

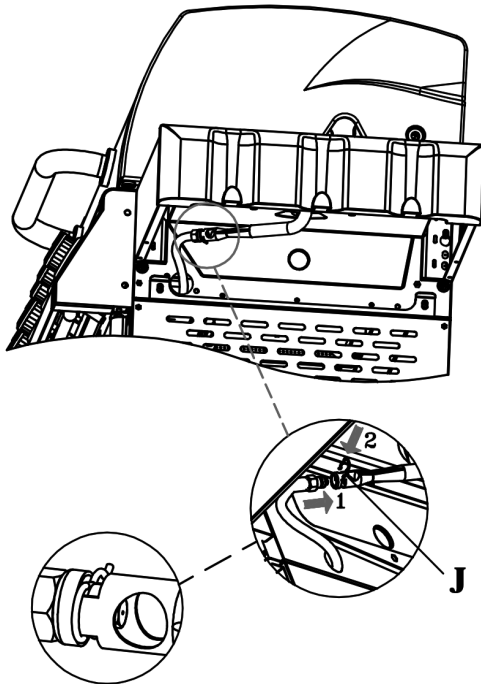

J		1PC
---	---	-----

24

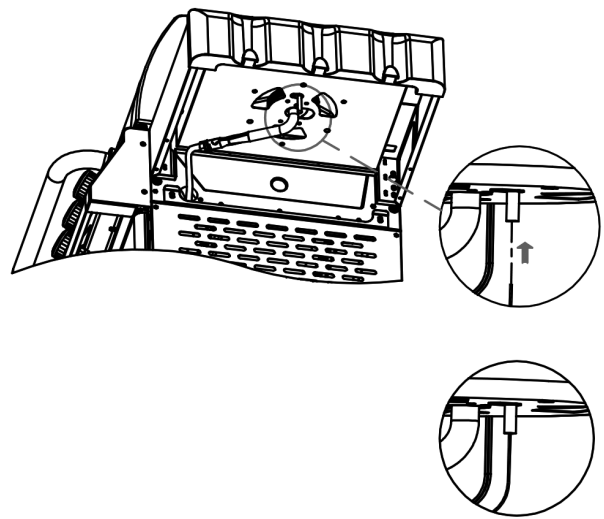

25

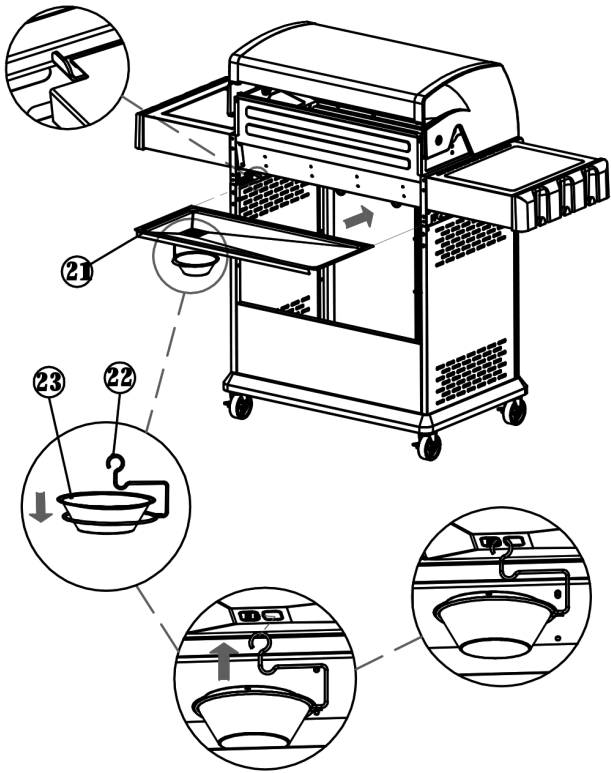

26

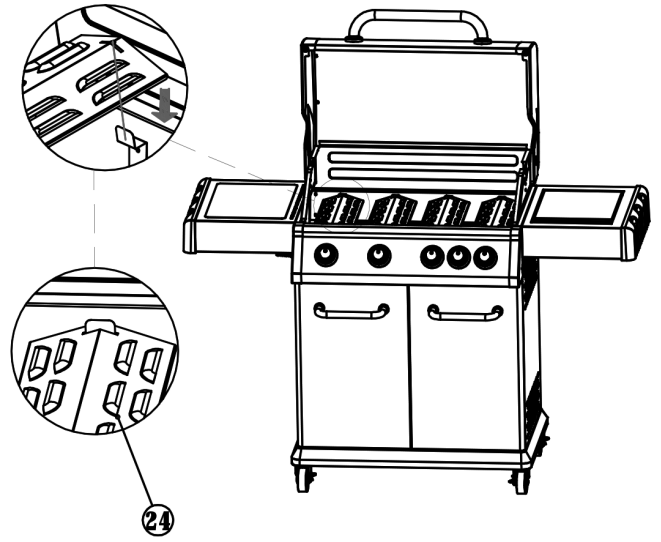

27

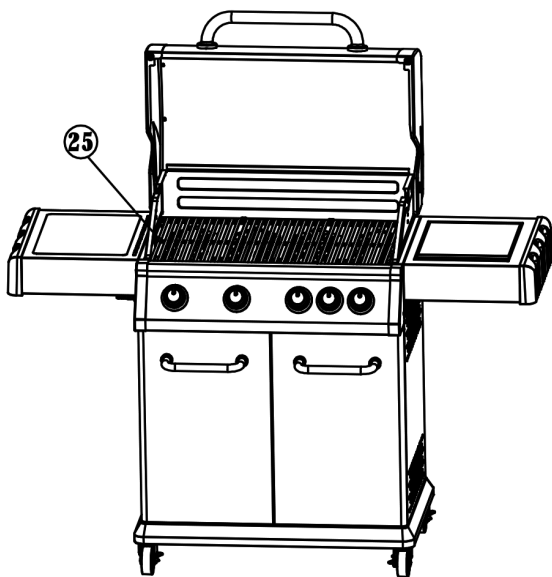

28

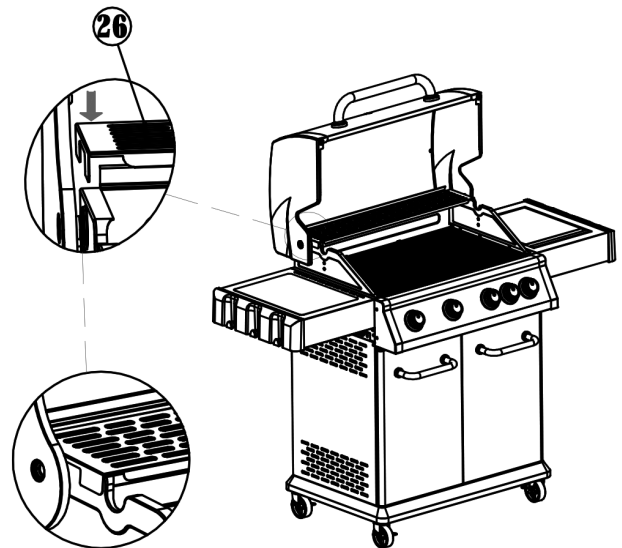

29

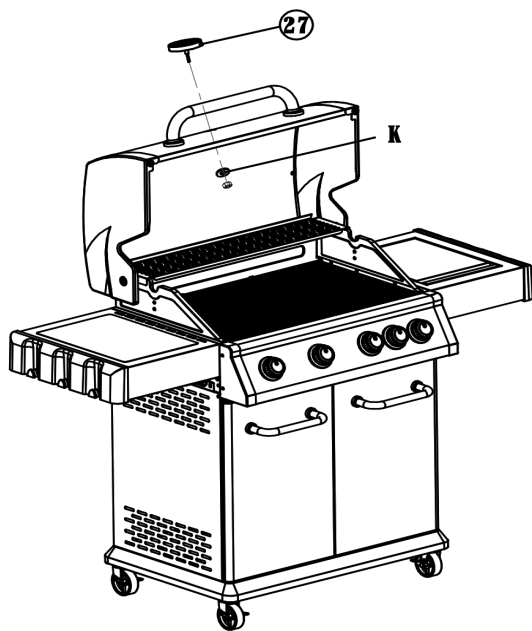

K



1PC

30

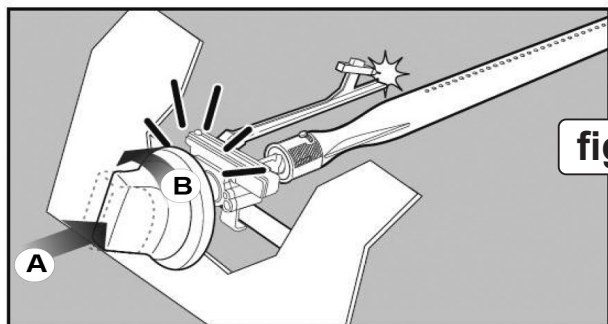
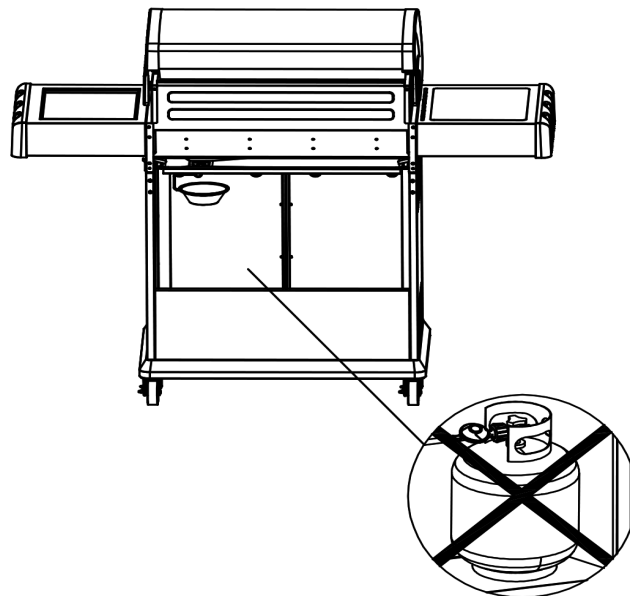
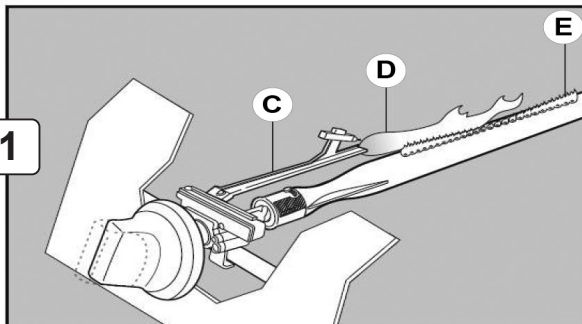

fig.1



Assembly

- Refer to diagrams 1-30.
- Ensure the barbecue is assembled properly.
- **CAUTION** It is inherent with fabricated steel parts that edges and corners can cause cuts if improperly handled during assembly. **BE CAREFUL** and wear correct work gloves.
- Attach gas hose to regulator. Secure with worm drive clip. Attach hose/regulator assembly to burner supply pipe on side of barbecue, secure with worm drive clip.

Preparation

- **ATTACH THE GAS BOTTLE**
- **Changing of gas bottles should be carried out away from any source of ignition. Make sure the barbecue is turned off.**
- Position your gas cylinder at the side of your barbecue, **not underneath**, remember the cylinder must be kept away from heat, and be in a safe position.
- Attach the regulator to the gas cylinder.
- Perform the Gas Leak Test as described in Safety Precautions.
- Check that all areas under the front panel are free from any obstructions (insects etc.). This area must be kept clean as this may affect the flow of combustion or of ventilation air.
- Check the hose before each and every use, looking for cracks, cuts or any abrasions.
- If the hose is found to be faulty in any way, **DO NOT** attempt to use your barbecue, replace the hose with one from Dellonda.
- Ensure the hose is free from any kinks or bends which will affect the gas flow, when using your barbecue. Also the hose must not have undue tension and must not touch any part of the barbecue which may be hot. The hose must not be longer than 1.5 metres.
- The barbecue must be kept away from flammable materials.
- **DO NOT** move the barbecue whilst in use.

Operation

- **WARNING!** In the event of a leak turn off the gas supply at the bottle. Extinguish any open flames, open lid and if leak continues, check for damage, poor connections etc.
- Contact your local stockist if problem can not be solved.
- **DO NOT** move during use.
- **DO NOT** store any flammable liquids in the vicinity of use.
- Only use outdoors.
- **DO NOT** use a naked flame to check for gas leaks. **DO NOT** disconnect any gas fitting part whilst in use.
- **DO NOT** leave unattended in use.
- Turn off at gas bottle after use.
- **WARNING!** The lid must be open when lighting the barbecue.
- **WARNING! DO NOT** stand with your face directly over the barbecue when lighting it.
- 1. Open lid.
- 2. Make sure all gas controls on the barbecue are in the **OFF** position. (See fig.2).
- 3. Connect regulator to the gas bottle. Turn the gas cylinder valve to the **ON** position at the regulator.
- 4. Push down the control knob (fig.1A) and keep pressing while turning anticlockwise to the high position. This will cause the piezo electric system to spark. and the gas in the lighting tube (fig.1C) will ignite.
- 5. Continue holding the control knob for a further few seconds to allow gas flow to reach the end of the burner tube (fig.1E) and be fully lit.
- 6. If the burner has not lit, turn knob off, wait 5 minutes and repeat above step.
- 7. Repeat step 4 to 5 for the other burners.
- **TO TURN OFF:** Turn burners to **OFF** positions. Wait until the burner has gone out.
- Turn off the tap on the gas bottle regulator.
- Clean after use.
- If using **BBQ** grill mats please ensure that the lid remains open throughout use to allow heat dispersal. Please leave at least a 50mm gap between the edge of the grill mat and the edge of the **BBQ**.

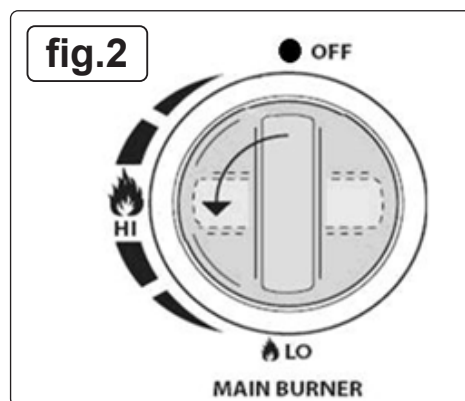

Maintenance

- Perform Maintenance at least once a year in order to extend the life of your barbecue.
- The hose should be renewed if damaged.

CLEANING

- To clean the barbecue, turn the burner on for 5 to 10 minutes. Grease will be burned off from the grill as well as the Flame Tamer Plate.
- Ensure the barbecue is cold before continuing. The grill should be cleaned periodically by soaking and washing in soapy water. Use a wire brush, steel wool or a scouring pad to remove stubborn spots. Always rinse thoroughly with clean water.
- The interior surfaces of the grill housing cover should be washed with hot soapy water.
- Regularly clean the drip tray reservoir with hot soapy water. It is sited beneath the barbecue at the back and will be hot whilst the barbecue is in use.
- Periodically check the burners to see that are free from insects and spiders which may block the gas system.
- Clean the venturi tube on the burner very carefully, checking to see that it is free of obstructions. We recommend the use of a pipe cleaner to clean the venturi tube area.

STORAGE

- The gas bottle must be stored outdoors in a well ventilated area and must be disconnected from your barbecue when not being used.
- Ensure that you are outside and well away from any sources of ignition before disconnecting your bottle.
- When using your barbecue after a period of storage, check for gas leaks and for any obstructions in the burner before using. Also follow the cleaning instructions to ensure the barbecue is safe. Check that areas under the lid and flame tamer are free from any obstruction, (insect, ingress etc.). This area must be kept clean, as it may affect the flow of combustion or air.
- We recommend you use a barbecue cover to protect this item when not in use. Ensure it is cool before the cover is used. Covers must be removed periodically to minimise moisture build up.

Problem	Possible cause	Solution
Gas leaking from cut/cracked/ burned hose	Damaged hose	Turn off gas at LP bottle, if hose is cut or cracked replace hose.
Gas leaking from LP bottle	Mechanical failure due to resting or manhandling	Turn off LP bottle valve
Gas leaking from LP bottle valve	Failure of LP bottle valve from mishandling or mechanical failure	Turn off LP bottle valve. Return gas bottle to Gas supplier
Gas leaking between LP bottle and regulator connection	Improper installation, connection not tight, failure of rubber seal	Turn off LP bottle, remove regulator from bottle and visually inspect rubber seal for damage.
Fire coming through control panel	Fire in burner tube section of burner due to partial blockage	Turn off control knobs and LP bottle valve. After fire is out and grill is cold, remove burner and inspect for spider nests or rust.
Grease fire or continuous excessive flames above the cooking surface	Too much grease build up in the burner area	Turn off LP bottle. Leave lid open to allow flames to die down. After cooling, clean food particles and excess grease from inside the firebox area, grease cup/pan tray and other surfaces

Burner will not ignite using igniter	Gas issues 1. Trying to light wrong burner 2. Burner not engaged with control valve 3. Obstruction in burner 4. No gas flow 5. Vapour lock at coupling nut to LP bottle 6. Coupling nut at LP bottle valve not fully connected	1. See control panel section and Use and Care 2. Make sure valves are positioned inside burner tubes 3. Ensure burner tubes are not obstructed with spider webs or other material. 4. Make sure LP bottle is not empty 5. Turn off knobs and disconnect coupling nut from LP bottle. Reconnect and retry 6. Turn nut until properly connected
Burner will not light using igniter	Electrical issues: 1. Electrode cracked or broken (sparks at crack) 2. Electrode tip not in proper position 3. Wire and/or electrode covered with a cooking residue. 4. Wires are loose or disconnected 5. Wires are sparking (shorting) between igniter and electrode 6. Push button sticks at bottom causing sparking between igniter and electrode 7. Inspect wire insulation for proper connection	1. Replace electrode 2. Tip of electrode should be pointing toward port hole in burner. The distance should be 3.18mm (1/8") to 4.77mm (3/16"). Adjust if necessary 3. Clean wire and/or electrode with rubbing alcohol and clean swab. 4. Reconnect wires or replace electrode/wire assembly 5. Replace igniter wire 6. Replace igniter. test 7. Replace wires if insulation is broken
Burner will not match light	1. See 'Gas issues' above	
Sudden drop in gas flow or low flame	1. Grease build up 2. Excessive fat in meat 3. Excessive cooking temperature	1. Clean burners and inside of grill/firebox 2. Trim fat from meat before grilling 3. Adjust as necessary
Flames blow out	High or gusting winds. Low on LP gas.	Turn front of grill to face wind or increase flame height Refill gas See also 'Sudden drop section' above
Persistent grease fire	Grease trapped by food build up around burner system	Turn knobs to OFF. Turn gas off at LP bottle. Leave lid in position and let fire burn out. After grill cools, remove and clean all parts
Flashback	Burner and burner tubes are blocked	Turn knobs to OFF. Turn gas off at gas bottle. See burner cleaning section of manual
Flare up	1. Grease build up	1. Clean burners and inside of grill/firebox
One burner does not light from other burner/s	Grease build up or food particles in end of carry over tube	Clean carry over tube with wire brush

If the issue is not resolved by carrying out the above procedures please contact Dellonda.

Environment Protection and Waste Protection and Electrical Equipment Regulations (WEEE)

Recycle unwanted packaging materials. When this product is no longer required, or has reached the end of its useful life, please dispose of it in an environmentally friendly way. Drain any fluids (if applicable) into approved containers, in accordance with local waste regulations. Under the Waste Batteries and Accumulators Regulations 2009, Dellonda would like to inform the user that this product contains one or more batteries. It is our policy to continually improve products and we reserve the right to alter data, specifications and parts without prior notice. No liability is accepted for incorrect use of this product. Guarantee is 12 months from purchase date, proof of which is required for any claim.

Dellonda Limited

Kempson Way, Suffolk Business Park, Bury St Edmunds, Suffolk. IP32 7AR



01284 757575



support@dellonda.co.uk



www.dellonda.co.uk