

ASSEMBLY INSTRUCTION

Warning:pls do not fasten the screw tight when assembly.until all the screws put into the screw holes,keep the screws loose during assemble bed

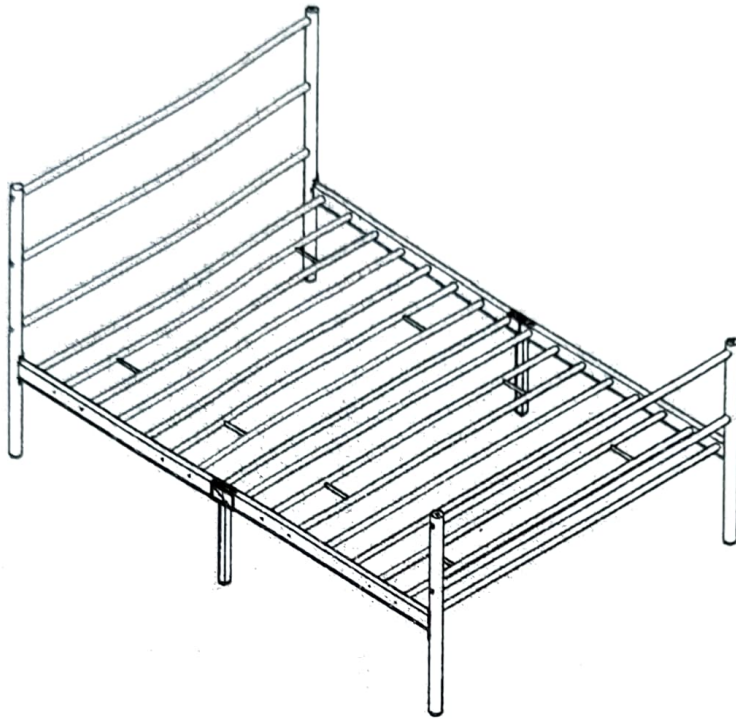

A. 2PCS



B. 2PCS



C. 5PCS



D. 2PCS

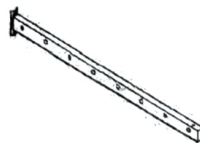

E. 2PCS

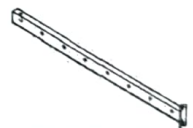

F. 4PCS

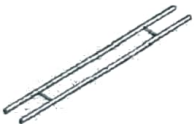

G. 8PCS



H. 2PCS



I. 16PCS



1. M8*20
8PCS



2. M6*16
16PCS



3. M6*60
14PCS



4. M6
4PCS



5. M5
1PCS



6. M10
1PCS



7. 10PCS



ASSEMBLY INSTRUCTION

1

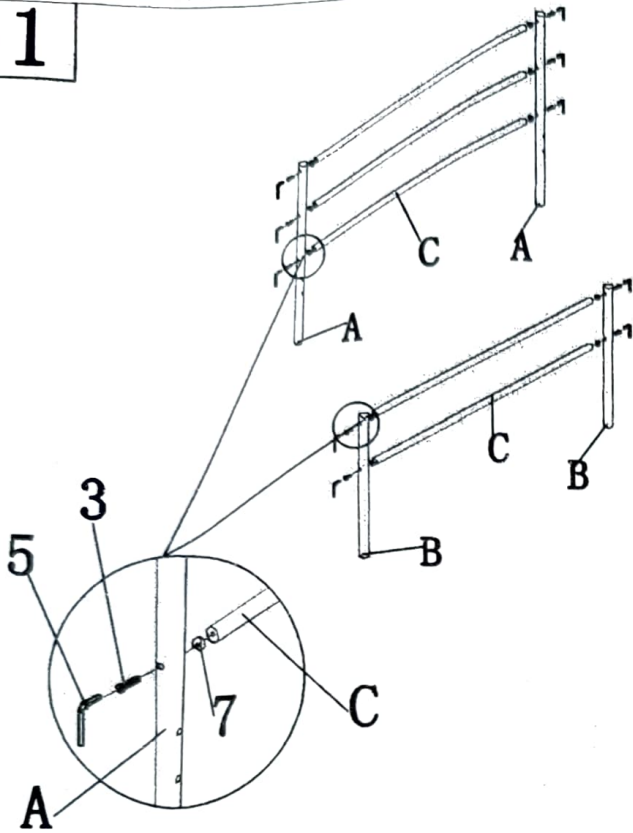

2

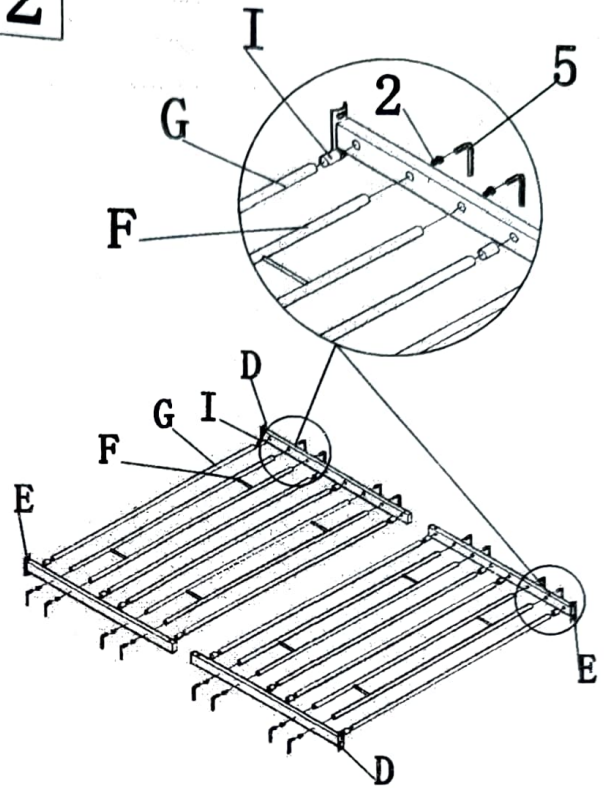

3

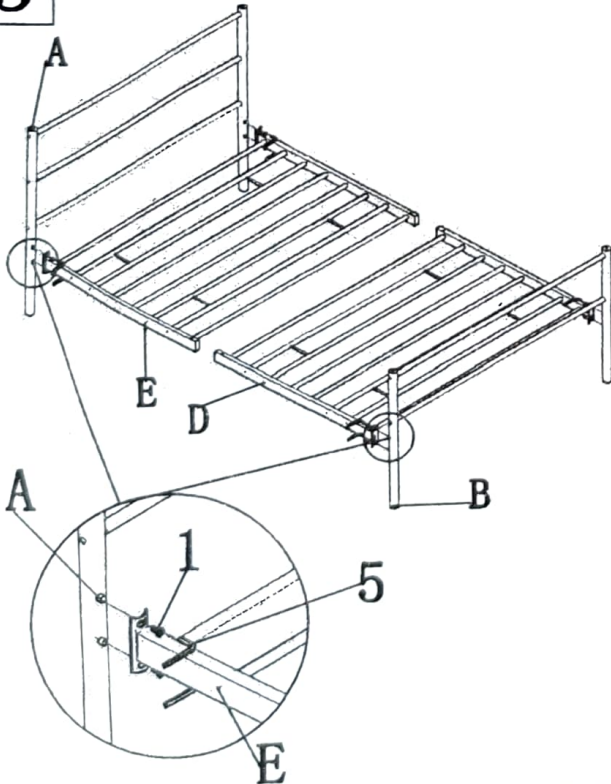

4

